

IEC Appliance Inlet C6, Screw-on Mounting, Front Side, Solder Terminal

**Description**

- Panel Mount:
Screw-on mounting from front or rear-side
- Appliance Inlet, Pin temperature 70 °C, Protection class I
- Solder terminals for wires or PCB

Approvals

- VDE License Number: 40017309
- UL License Number: E96454
- CSA License Number: 73165

References

[General Product Information](#)

Weblinks

[Approvals](#), [RoHS](#), [CHINA-RoHS](#), [Mating Connectors](#), [e-Store](#), [Distributor-Stock-Check](#), [Accessories](#)

Technical Data

Ratings IEC	2.5 A / 250 VAC; 50 Hz
Ratings UL/CSA	2.5 A / 250 VAC; 60 Hz
Dielectric Strength	> 2 kVAC between L-N > 2 kVAC between L/N-PE (1 min/50 Hz)
Allowable Operation Temp.	-25 °C to 70 °C
Degree of Protection	from front side IP 40 acc. to IEC 60529
Protection Class	Suitable for appliances with protection class 1 acc. to IEC 61140
Terminal	Solder terminals for wires or PCB
Panel Thickness s	Screw: max 4 mm Mounting screw torque max 0.5 Nm
Material: Housing	Thermoplastic, black, UL 94V-0

Appliance Inlet	C6 acc. to IEC/EN 60320-1, UL 498, CSA C22.2 no. 42 (for cold conditions) pin-temperature 70 °C, 2.5 A, Protection Class 1
-----------------	--

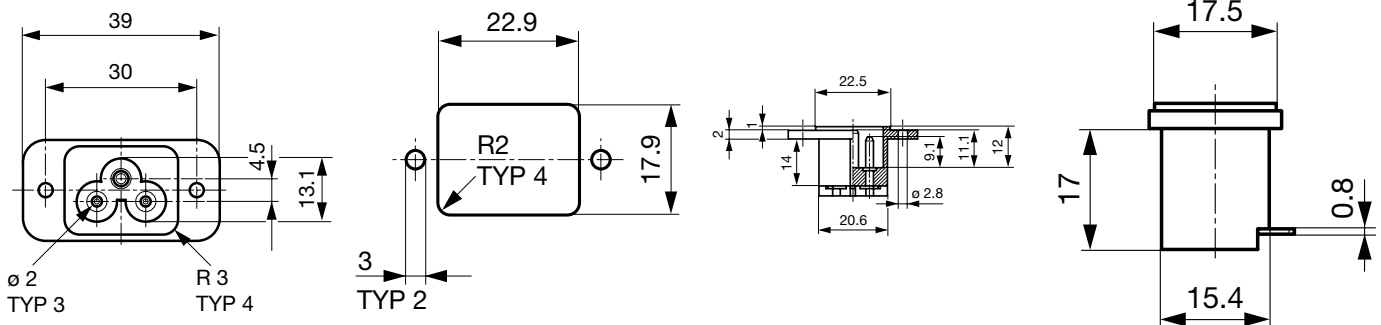
Dimensions**Solder terminals for PCB**

Solder terminals for wires

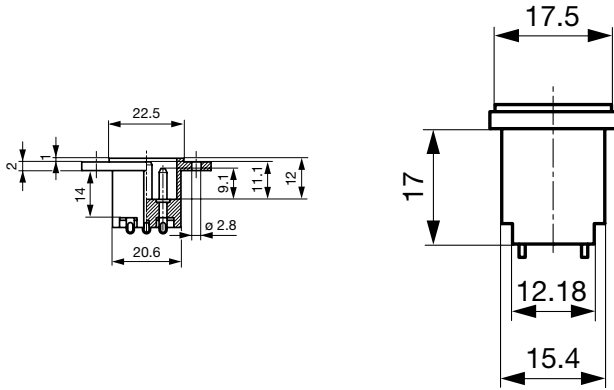

Drilling diagrams

PCB Layout

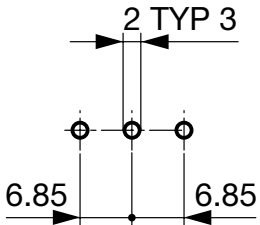

Variants

Type	Panel mounting	Panel Thickness s [mm]	Terminal	Order Number
0724	Screw	4	PCB	4300.0101
0724	Screw	4	Solder terminals	4300.0100

Packaging unit

100 Pcs

Mating Outlets/Connectors

Category / Description



[Power Cord Overview complete](#)

Power Cord with IEC Connector C5, Angled 2512

Power Cord with IEC Connector C5, Straight 2530

[Power Cord further types to 0724](#)