

4

3

2

1

THIS DRAWING IS UNPUBLISHED. RELEASED FOR PUBLICATION 20  
 © COPYRIGHT 20 BY TYCO ELECTRONICS CORPORATION. ALL RIGHTS RESERVED.

LOC FT  
 DIST 0

REVISIONS					
P	LTR	DESCRIPTION	DATE	DWN	APVD
B		REVISED PER 0G3B-0119-01	06FEB2002	EZ	DB
C		REVISED EC 0G3B-0401-04	02JUN2004	SW	CR
C1		REVISED PER ECO-08-021895	04SEP2008	HMR	CR
C2		REVISED PER ECO-08-022366	09SEP2008	HMR	CR

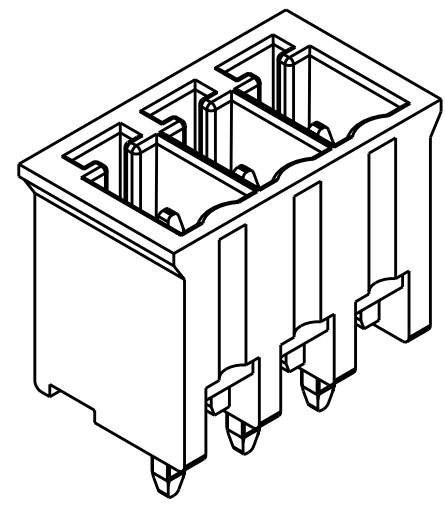

284514-3 AS SHOWN

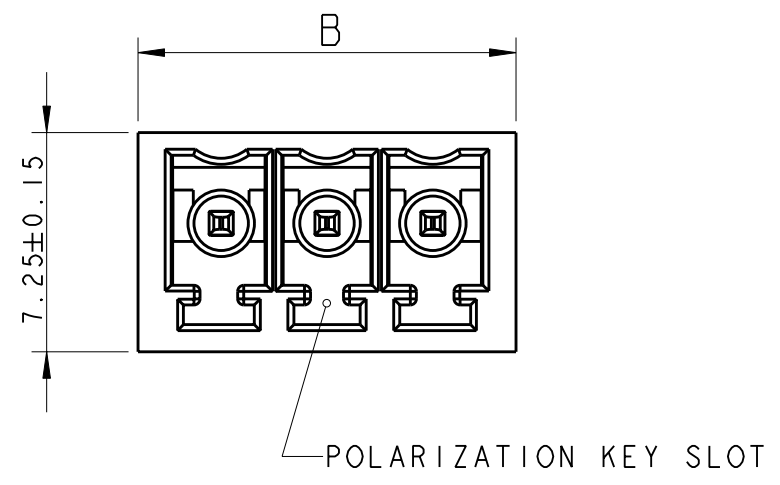
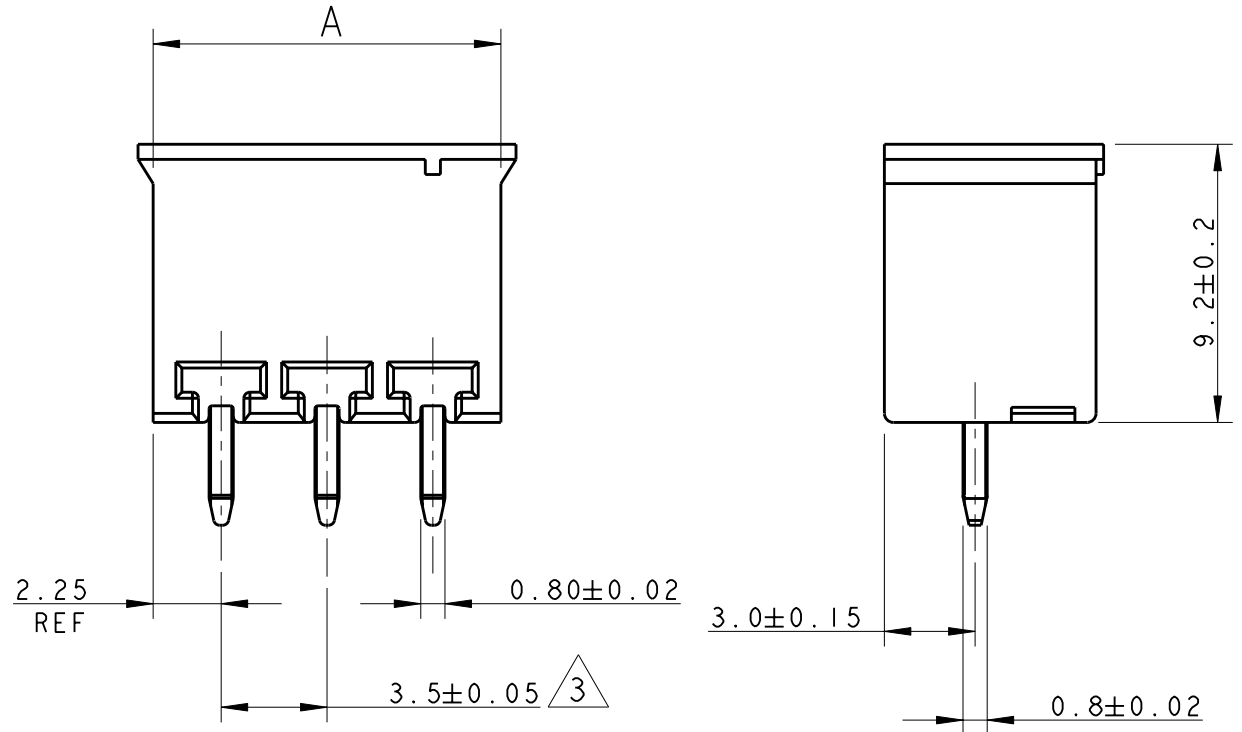

- 1 MATERIALS AND FINISH  
 HOUSING : PA 6.6, UL 94-V0, COLOR GREEN  
 TERMINAL : PHOSPHOR BRONZE, SEE TABLE
- 2 SUITABLE FOR 1.6-2.4 mm. PC BOARD THICKNESS
- 3 NOT CUMULATIVE TOLERANCE
- 4 PRELIMINARY PART NUMBER

4	AU	FL				
TIN	89.5	88.5	25	2-284514-5		
TIN	86.0	85.0	24	2-284514-4		
TIN	82.5	81.5	23	2-284514-3		
TIN	79.0	78.0	22	2-284514-2		
TIN	75.5	74.5	21	2-284514-1		
TIN	72.0	71.0	20	2-284514-0		
TIN	68.5	67.5	19	1-284514-9		
TIN	65.0	64.0	18	1-284514-8		
TIN	61.5	60.5	17	1-284514-7		
TIN	58.0	57.0	16	1-284514-6		
TIN	54.5	53.5	15	1-284514-5		
TIN	51.0	50.0	14	1-284514-4		
TIN	47.5	46.5	13	1-284514-3		
TIN	44.0	43.0	12	1-284514-2		
TIN	40.5	39.5	11	1-284514-1		
TIN	37.0	36.0	10	1-284514-0		
TIN	33.5	32.5	9	284514-9		
TIN	30.0	29.0	8	284514-8		
TIN	26.5	25.5	7	284514-7		
TIN	23.0	22.0	6	284514-6		
TIN	19.5	18.5	5	284514-5		
TIN	16.0	15.0	4	284514-4		
TIN	12.5	11.5	3	284514-3		
TIN	9.0	8.0	2	284514-2		
PLATING	B	A	NO OF POSN	PART NUMBER		

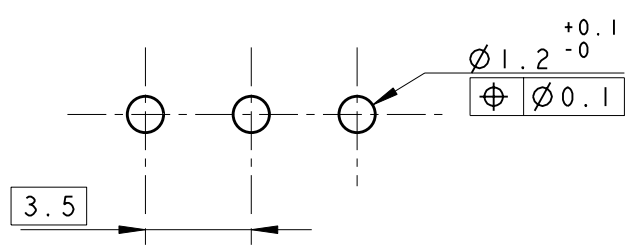

THIS DRAWING IS A CONTROLLED DOCUMENT FOR TYCO ELECTRONICS CORPORATION. IT IS SUBJECT TO CHANGE AND THE CONTROLLING ENGINEERING ORGANIZATION SHOULD BE CONTACTED FOR THE LATEST REVISION.		DWN 06FEB2002 E. ZANOLINI	Tyco Electronics Harrisburg, PA 17105-3608	
DIMENSIONS: mm		CHK 06FEB2002 E. ZANOLINI	NAME TERMINAL BLOCK, HEADER ASSEMBLY STRAIGHT, CLOSED ENDS 3.5mm PITCH	
TOLERANCES UNLESS OTHERWISE SPECIFIED:		APVD 06FEB2002 D. BIEVENOUR		
0 PLC ±.3 1 PLC ±.3 2 PLC ±.25 3 PLC ±. 4 PLC ±. ANGLES ±2		PRODUCT SPEC 108-20166	SIZE A3	CAGE CODE 00779
MATERIAL 1		APPLICATION SPEC 114-20079	DRAWING NO C-284514	RESTRICTED TO -
FINISH 1		WEIGHT -	SCALE 4:1 SHEET 1 OF 1 REV C2	
CUSTOMER DRAWING				