

Silicon PNP Power Transistors

2SB1193

DESCRIPTION

- With TO-220Fa package
- High DC current gain
- High speed switching
- DARLINGTON
- Complement to type 2SD1773

APPLICATIONS

- For medium speed switching applications

PINNING

PIN	DESCRIPTION
1	Base
2	Collector
3	Emitter

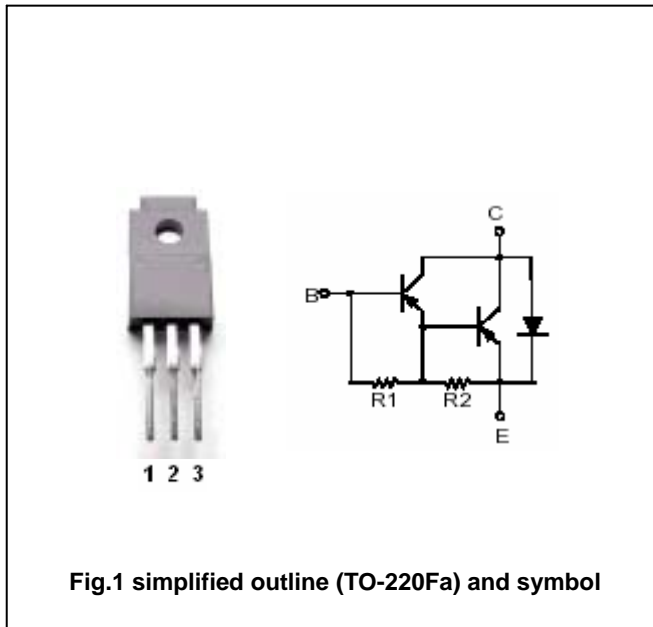

Fig.1 simplified outline (TO-220Fa) and symbol

Absolute maximum ratings(Ta=25)

SYMBOL	PARAMETER	CONDITIONS	VALUE	UNIT
V _{CBO}	Collector-base voltage	Open emitter	-120	V
V _{CEO}	Collector -emitter voltage	Open base	-120	V
V _{EBO}	Emitter-base voltage	Open collector	-7	V
I _C	Collector current		-8	A
I _{CM}	Collector current-peak		-12	A
P _C	Collector power dissipation	T _a =25	2	W
		T _C =25	50	
T _j	Junction temperature		150	
T _{stg}	Storage temperature		-55~150	

Silicon PNP Power Transistors

2SB1193

CHARACTERISTICS

T_j=25 unless otherwise specified

SYMBOL	PARAMETER	CONDITIONS	MIN	TYP.	MAX	UNIT
V _{CEO(SUS)}	Collector-emitter sustaining voltage	I _C =-2A; R _{BE} = ; L=10mH	-120			V
V _{(BR)EBO}	Emitter-base breakdown voltage	I _E =-50mA; I _C =0	-7			V
V _{CEsat-1}	Collector-emitter saturation voltage	I _C =-4A ; I _B =-8mA			-1.5	V
V _{CEsat-2}	Collector-emitter saturation voltage	I _C =-8A ; I _B =-80mA			-3.0	V
V _{BEsat-1}	Base-emitter saturation voltage	I _C =-4A ; I _B =-8mA			-2.0	V
V _{BEsat-2}	Base-emitter saturation voltage	I _C =-8A ; I _B =-80mA			-3.5	V
I _{CBO}	Collector cut-off current	V _{CB} =-120V; I _E =0			-100	μ A
I _{CEO}	Collector cut-off current	V _{CE} =-100V; R _{BE} =			-10	μ A
h _{FE}	DC current gain	I _C =-4A ; V _{CE} =-3V	1000		20000	

Switching times

t _{on}	Turn-on time	I _C =-4A ; I _{B1} =-I _{B2} =-8mA V _{CC} =-50V		0.7		μ s
t _{stg}	Storage time			3.5		μ s
t _f	Fall time			2.0		μ s

PACKAGE OUTLINE

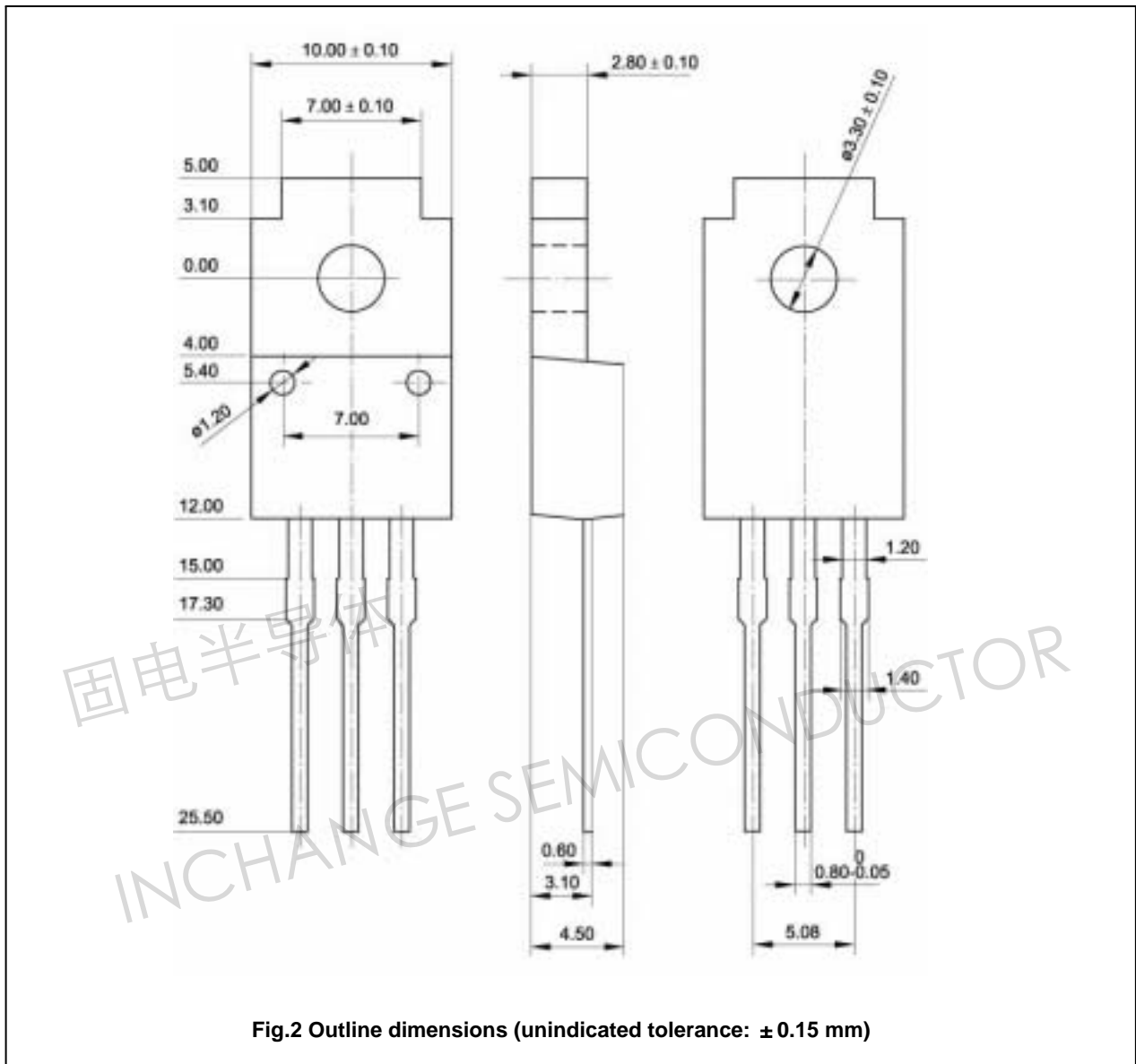

Fig.2 Outline dimensions (unindicated tolerance: ± 0.15 mm)