

High Voltage Fast-Switching NPN Power Transistor

Features

- ◆ Very High Switching Speed
- ◆ High Voltage Capability
- ◆ Wide Reverse Bias SOA

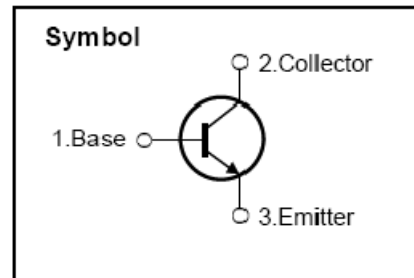

General Description

This Device is designed for high voltage, High speed switching characteristics required such as lighting system, switching mode power supply.

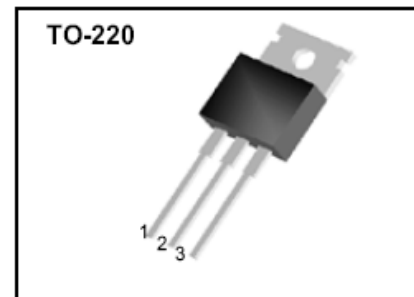

Absolute Maximum Ratings

Symbol	Parameter	Test Conditions	Value	Units
V_{CES}	Collector-Emitter Voltage	$V_{BE} = 0$	1100	V
V_{CEO}	Collector-Emitter Voltage	$I_B = 0$	800	V
V_{EBO}	Emitter-Base Voltage	$I_C = 0$	7.0	V
I_C	Collector Current		3.0	A
I_{CP}	Collector pulse Current		10	A
I_B	Base Current		1.5	A
I_{BM}	Base Peak Current	$t_P = 5ms$	3.0	A
P_C	Total Dissipation at $T_c = 25^\circ C$		50	W
	Total Dissipation at $T_a = 25^\circ C$		2.08	
T_J	Operation Junction Temperature		- 40 ~ 150	$^\circ C$
T_{STG}	Storage Temperature		- 40 ~ 150	$^\circ C$

T_c : Case temperature (good cooling)

T_a : Ambient temperature (without heat sink)

Thermal Characteristics

Symbol	Parameter	Value	Units
$R_{\theta JC}$	Thermal Resistance Junction to Case	1.67	$^\circ C/W$
$R_{\theta JA}$	Thermal Resistance Junction to Ambient	62.5	$^\circ C/W$

SBP5027-R

Electrical Characteristics (T_c=25°C unless otherwise noted)

Symbol	Parameter	Test Conditions	Value			Units
			Min	Typ	Max	
V _{CEO(sus)}	Collector-Emitter Breakdown Voltage	I _c =5mA, I _b =0	800	-	-	V
V _{CE(sat)}	Collector-Emitter Saturation Voltage	I _c =1.5A, I _b =0.3A	-	-	2	V
V _{BE(sat)}	Base-Emitter Saturation Voltage	I _c =1.5A, I _b =0.3A	-	-	1.5	V
I _{CBO}	Collector-Base Cutoff Current	V _{cb} =800V, I _e =0	-	-	10	μA
I _{EBO}	Emitter -Base Cutoff Current	V _{eb} =5V, I _c =0	-	-	10	μA
h _{FE}	DC Current Gain	V _{ce} =5V, I _c =0.2A V _{ce} =5V, I _c =1.0A	10 8	- -	40 -	
C _{ob}	Output Capacitance	V _{cb} =10V, f _T =1MHz	-	60	-	pF
t _{on}	Turn on Time	V _{CC} =400V			0.5	
t _s	Storage Time	I _c =5I _{B1} =-2.5 I _{B2} =2A	-	-	3.0	μs
t _f	Fall Time	R _L =200 Ω	-	-	0.3	

Note:

Pulse Test : Pulse width 300, Duty cycle 2%

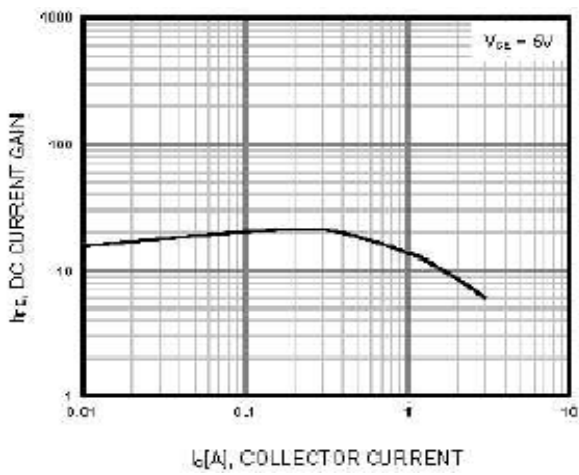

Fig. 1 DC Current Gain

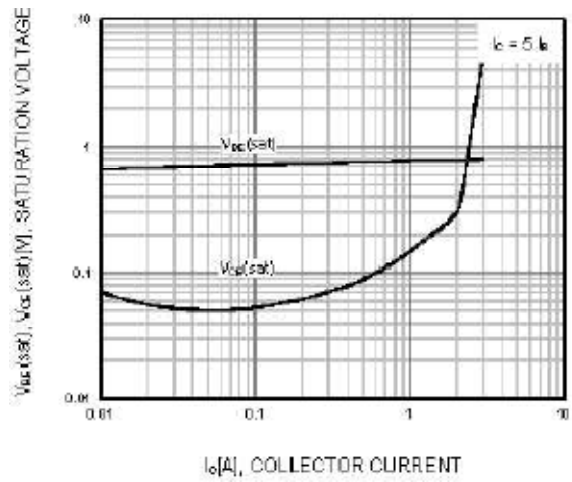

Fig. 2 Saturation Voltage

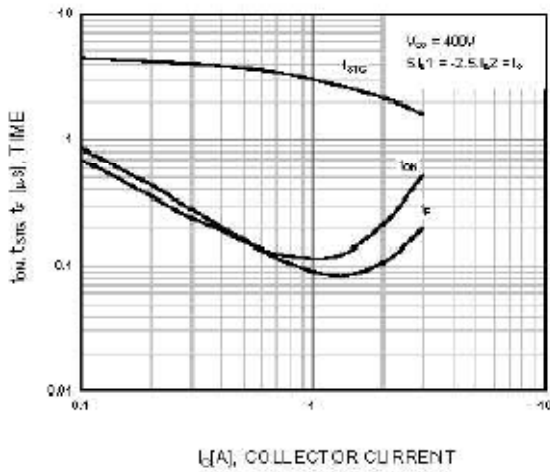

Fig. 3 Switching Time

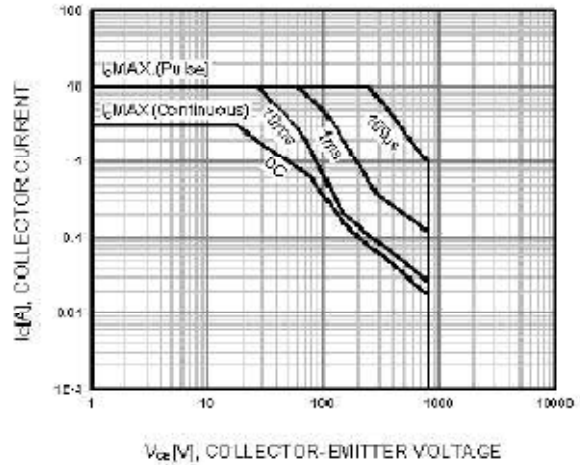

Fig. 4 Safe Operation Area

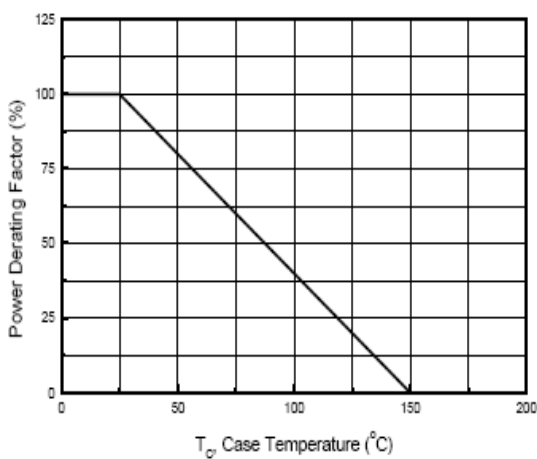

Fig. 5 Power Derating

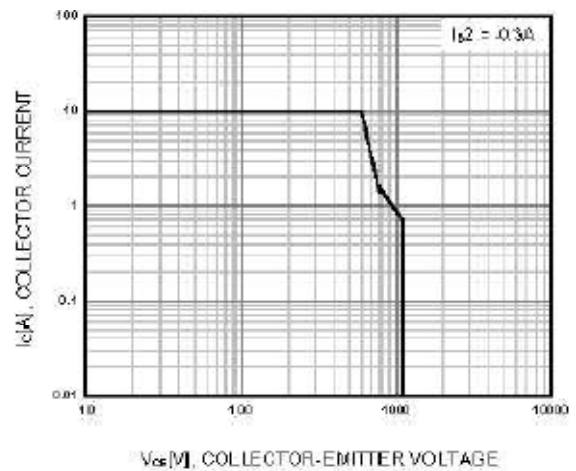
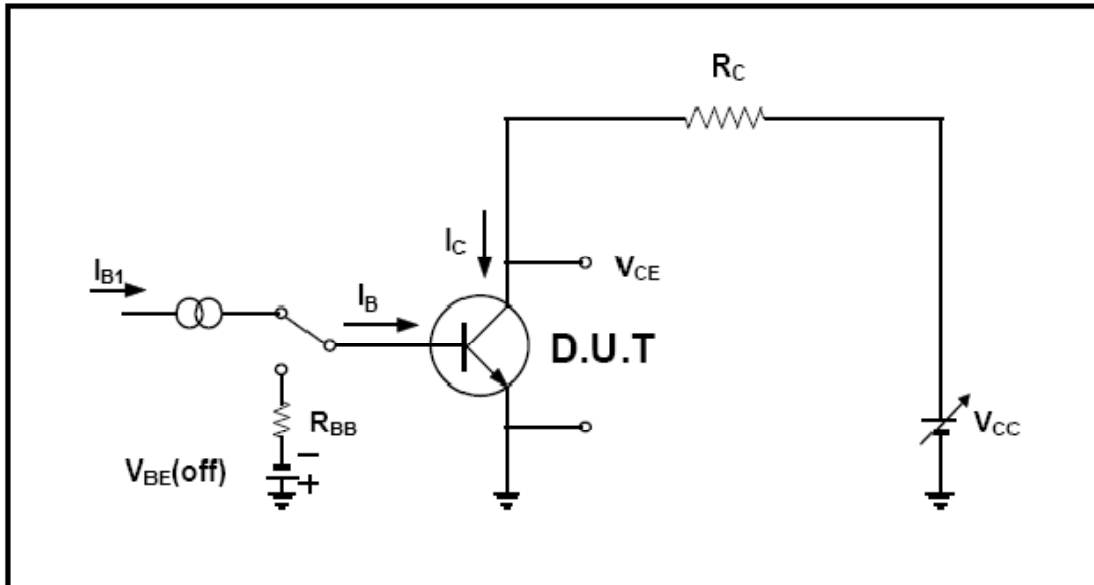

Fig. 6 Reverse Biased Safe Operation Area

SBP5027-R

Resistive Load Switching Test Circuit



Inductive Load Switching & RBSOA Test Circuit

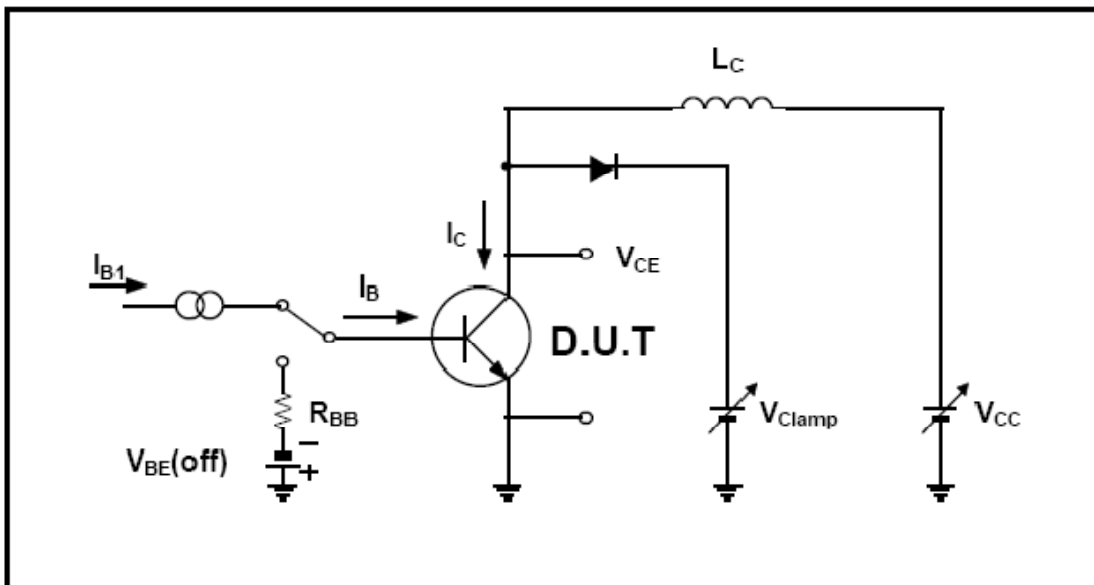

TO-220 Package Dimension

Unit: mm

