

MECHANICAL DATA

Dimensions in mm.

P.I.N. PHOTODIODE

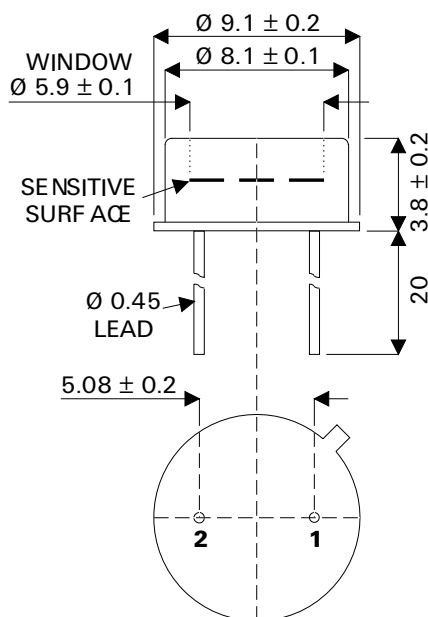

TO-39 Package

Pin 1 – Anode

Pin 2 – Cathode & Case

FEATURES

- HIGH SENSITIVITY
- VISIBLE AND UV BLIND
- EXCELLENT LINEARITY
- LOW NOISE
- WIDE SPECTRAL RESPONSE
- RG850 INTEGRAL OPTICAL FILTER
- TO39 HERMETIC METAL CAN PACKAGE
- EMI SCREENING MESH AVAILABLE

DESCRIPTION

The SMP600G-EM is a Silicon P.I.N. photodiode incorporated in a hermetic metal can package. The electrical terminations are via two leads of diameter 0.018" on a pitch of 0.2". The can structure incorporates an optical filter that only transmits infra-red light. The cathode of the photodiode is electrically connected to the package.

The larger photodiode active area provides greater sensitivity than the SMP550 range of devices, with a slight reduction in speed. Inherent in the device geometry is a reduction in the receiving angle. The photodiode structure has been optimised for high sensitivity, light measurement applications. The metal can and optional screening mesh ensure a rugged device with a high degree of immunity to radiated electrical interference.

ABSOLUTE MAXIMUM RATINGS (T_{case} = 25°C unless otherwise stated)

Operating temperature range	-40°C to +70°C
Storage temperature range	-45°C to +80°C
Temperature coefficient of responsivity	0.35% per °C
Temperature coefficient of dark current	x2 per 8°C rise
Reverse breakdown voltage	60V

CHARACTERISTICS (T_{amb}=25°C unless otherwise stated)

Characteristic	Test Conditions.	Min.	Typ.	Max.	Units
Responsivity	λ at 900nm	0.45	0.55		A/W
Active Area			15		mm ²
Dark Current	E = 0 Dark 1V Reverse		2	6	nA
	E = 0 Dark 10V Reverse				
Breakdown Voltage	E = 0 Dark 10 μ A Reverse	60	80		V
Capacitance	E = 0 Dark 0V Reverse		90		pF
	E = 0 Dark 20V Reverse		25		
Rise Time	30V Reverse 50 Ω		12		ns
NEP	900nm		20x10 ⁻¹⁴	0.45	W/ \sqrt Hz

Directional characteristics

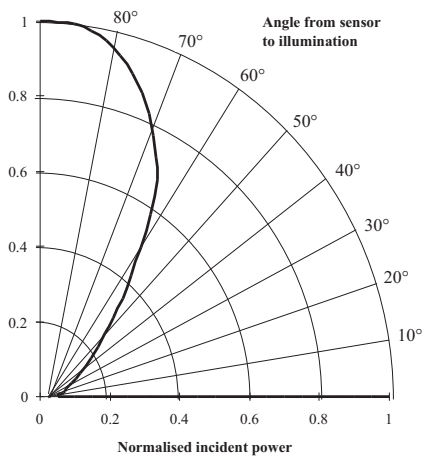

Directional Characteristics

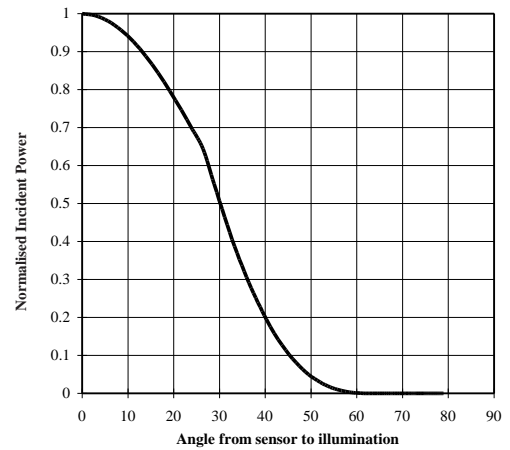

Spectral Response

