

DATA SHEET

TX6.6/2.7/4.8
Alloy powder toroids

New data

2008 Sep 01

Alloy powder toroids

TX6.6/2.7/4.8

RING CORES (TOROIDS)

Effective core parameters

SYMBOL	PARAMETER	VALUE	UNIT
$\Sigma(l/A)$	core factor (C1)	1.48	mm ⁻¹
V_e	effective volume	125	mm ³
l_e	effective length	13.6	mm
A_e	effective area	9.2	mm ²
m	mass of core (for μ_i 125)	MPP	1.09 g
		Sendust	0.77 g
		High-Flux	1.03 g

Coating

The cores are coated with epoxy. The colour is cream (Sendust), grey (MPP) or khaki (High-Flux). Maximum operating temperature is 200 °C. Parylene coating is also available (transparent, maximum operating temperature 130 °C).

Isolation voltage

AC isolation voltage : 1000 V (Parylene : 750 V).
Contacts are applied on the edge of the ring core, which is also the critical point for the winding operation.

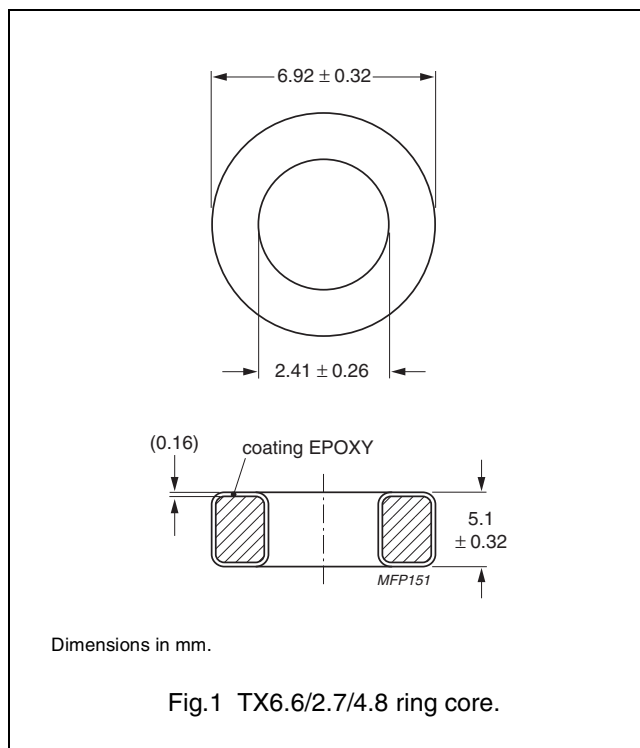

GRADE	A_L (nH)	μ_i	B (mT) at	CORE LOSS (W) at	TYPE NUMBER
			H = 100 kA/m; f = 10 kHz; T = 25 °C	f = 100 kHz; \hat{B} = 100 mT; T = 25 °C	
MPP	14 ± 8 %	14	≥ 640	0.188	TX6.6/4.8-M2-A14
	21 ± 8 %	26	≥ 700	0.150	TX6.6/4.8-M2-A21
	50 ± 8 %	60	≥ 760	0.094	TX6.6/4.8-M2-A50
	103 ± 8 %	125	≥ 800	0.094	TX6.6/4.8-M2-A103
	122 ± 8 %	147	≥ 800	0.100	TX6.6/4.8-M2-A122
	132 ± 8 %	160	≥ 800	0.100	TX6.6/4.8-M2-A132
	144 ± 8 %	173	≥ 800	0.100	TX6.6/4.8-M2-A144
	165 ± 8 %	200	≥ 800	0.188	TX6.6/4.8-M2-A165
Sendust	247 ± 8 %	300	≥ 800	0.188	TX6.6/4.8-M2-A247
	50 ± 12 %	60	≥ 1030	0.107	TX6.6/4.8-S7-A50
	62 ± 12 %	75	≥ 1040	0.107	TX6.6/4.8-S7-A62
	74 ± 12 %	90	≥ 1050	0.107	TX6.6/4.8-S7-A74
High-Flux	103 ± 12 %	125	≥ 1060	0.107	TX6.6/4.8-S7-A103
	12 ± 8 %	14	≥ 890	0.314	TX6.6/4.8-H2-A12
	21 ± 8 %	26	≥ 980	0.251	TX6.6/4.8-H2-A21
	50 ± 8 %	60	≥ 1280	0.226	TX6.6/4.8-H2-A50
	103 ± 8 %	125	≥ 1370	0.251	TX6.6/4.8-H2-A103
	122 ± 8 %	147	≥ 1385	0.276	TX6.6/4.8-H2-A122
	132 ± 8 %	160	≥ 1400	0.439	TX6.6/4.8-H2-A132

DATA SHEET STATUS DEFINITIONS

DATA SHEET STATUS	PRODUCT STATUS	DEFINITIONS
Preliminary specification	Development	This data sheet contains preliminary data. Ferroxcube reserves the right to make changes at any time without notice in order to improve design and supply the best possible product.
Product specification	Production	This data sheet contains final specifications. Ferroxcube reserves the right to make changes at any time without notice in order to improve design and supply the best possible product.

DISCLAIMER

Life support applications — These products are not designed for use in life support appliances, devices, or systems where malfunction of these products can reasonably be expected to result in personal injury. Ferroxcube customers using or selling these products for use in such applications do so at their own risk and agree to fully indemnify Ferroxcube for any damages resulting from such application.

PRODUCT STATUS DEFINITIONS

STATUS	INDICATION	DEFINITION
Prototype		These are products that have been made as development samples for the purposes of technical evaluation only. The data for these types is provisional and is subject to change.
Design-in		These products are recommended for new designs.
Preferred		These products are recommended for use in current designs and are available via our sales channels.
Support		These products are not recommended for new designs and may not be available through all of our sales channels. Customers are advised to check for availability.