

Chip Inductors

Type KQ 0805

ISO 9001:2000
CERTIFIED
TS-16949
CERTIFIED

1. Scope of Application

This specification shall be applied to chip inductors KQ series produced by KOA Corporation.

2. Dimensions and Construction

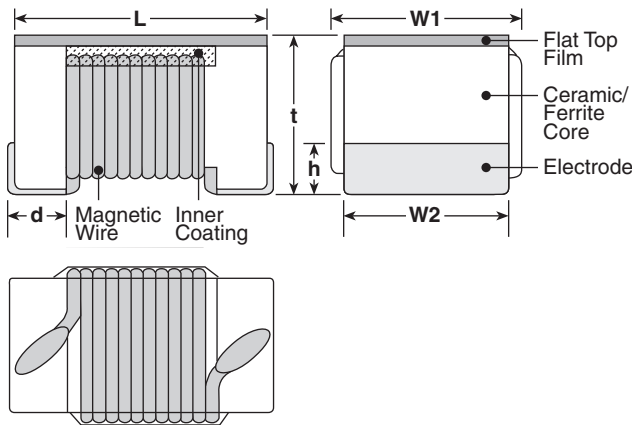

Size Code	Dimensions inches (mm)					
	L	W1	W2	t	h	d
KQ0805	.079±.008 (2.0±0.2)	.059±.008 (1.5±0.2)	.053±.004 (1.35±0.1)	.051±.008 (1.3±0.2)	.016±.006 (0.40±0.15)	.018±.004 (0.45±0.1)

3. Type Designation

Type designation shall be as the following form.

New Type

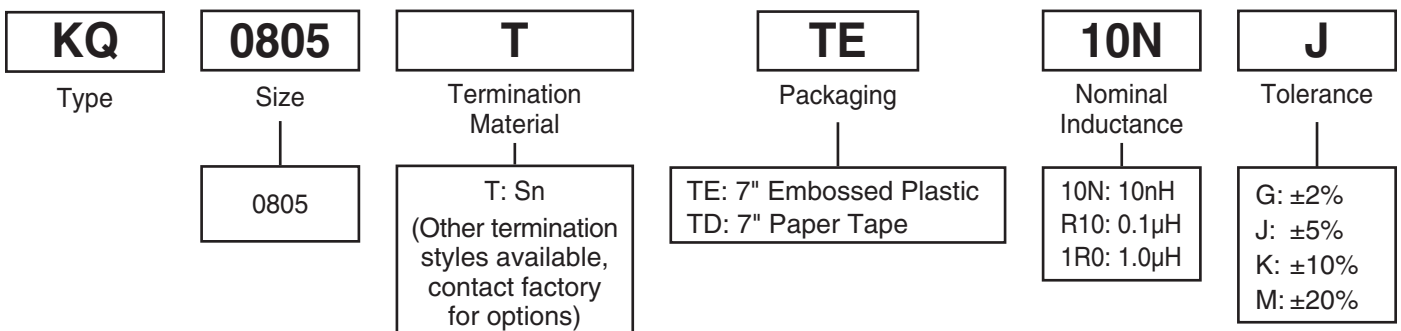

4. Standard Applications

Part Designation	Marking	Nominal Inductance (nH)	L Measuring Frequency	Inductance Tolerance	Q Quality Factor Minimum	Q Measuring Frequency (MHz)	Self Resonant Frequency Minimum (MHz)	DC Resistance Maximum (Ω)	Allowable DC Current Maximum (mA)
KQ0805TTE3N3*	0	3.3	250	J: $\pm 5\%$ K: $\pm 10\%$ M: $\pm 20\%$	50	1500	6000	0.08	600
KQ0805TTE6N8*	1	6.8				1000	5500	0.11	
KQ0805TTE8N2*	2	8.2					4700	0.12	
KQ0805TTE12N*	3	12		G: $\pm 2\%$ J: $\pm 5\%$ K: $\pm 10\%$ M: $\pm 20\%$	50	4000	0.15	500	
KQ0805TTE15N*	4	15				3400	0.17		
KQ0805TTE18N*	5	18				3300	0.20		
KQ0805TTE22N*	6	22				2600	0.22		
KQ0805TTE27N*	7	27		55	500	2500	0.25	500	
KQ0805TTE33N*	8	33				2050	0.27		
KQ0805TTE39N*	9	39		200	60	60	2000	0.29	500
KQ0805TTE47N*	0	47	1650				0.31		
KQ0805TTE56N*	1	56	1550				0.34		
KQ0805TTE68N*	2	68	150	65	65	1450	0.38	400	
KQ0805TTE82N*	3	82				1300	0.42		
KQ0805TTER10*	4	100	100	50	250	1200	0.46	400	
KQ0805TTER12*	5	120				1100	0.51		
KQ0805TTER15*	6	150				920	0.56		
KQ0805TTER18*	7	180	48	48	250	870	0.64	350	
KQ0805TTER22*	8	220				850	0.70		
KQ0805TTER27*	9	270	50	33	100	650	1.0	310	
KQ0805TTER33*	0	330				600	1.4		
KQ0805TTER39*	1	390	25	23	50	560	1.5	290	
KQ0805TTER47*	2	470				375	1.76		
KQ0805TTER56*	3	560	25	J: $\pm 5\%$ K: $\pm 10\%$	23	50	340	1.9	230
KQ0805TTER68*	4	680					188	2.2	
KQ0805TTER82*	5	820					215	2.35	

* Add tolerance character (G, J, K, M)

5. Rating

No.	Item	Specification
1	Storage temperature range	-40°C ~ +100°C
2	Operating temperature range	-40°C ~ +125°C

5.1 Measurement Method

Nominal Inductance Range	Test Equipment	Fixture	Setup	Measuring Frequency
3.3 nH to 820 nH	4291A RF Impedance analyzer (H.P)	16193A Test fixture	E.L = 1.4 cm OSC = 500 mV	Listed Table-1

6. Test Conditions

Unless otherwise specified, the test shall be performed at the temperature of $20\pm 15^{\circ}\text{C}$ and at a relative humidity of $65\pm 20\%$. Reverse for

the test conditions shall be performed at the temperature of $20\pm 2^{\circ}\text{C}$ and at a relative humidity of $65\pm 5\%$.

7. Reliability Tests

7-1 Electrical Characteristics

Item	Requirement	Test Methods
Dielectric withstanding voltage	No evidence of flaming, fuming, or breakdown	5 seconds at AC 500 V applied between both terminals and film.
Insulation resistance	1000M Ω and over	1 minute at DC 100 V measured between both terminals and film.
Flammability	IEC 695-2-2	Withstands needle-flame test.

7-2 Mechanical Characteristics

Item	Requirement	Test Methods
Terminal pull strength	No evidence of damage	Terminals shall withstand a pull of 10 N in a horizontal direction.
Terminal bending strength	No evidence of breakdown	Specimen shall be soldered on bend test board and force applied to the opposite side to cause a 10 mm deflection
Vibration	$\Delta L/L$ within $\pm 5\%$ $\Delta Q/Q$ within $\pm 10\%$	2 hours in each direction of X, Y, Z, on PCB at a frequency range of 10-55-10Hz with 1.5 mm amplitude
Dropping	No evidence of damage $\Delta L/L$ within $\pm 5\%$ $\Delta Q/Q$ within $\pm 10\%$	Dropping 1 m on the ground of concrete 1 time
Resistance to soldering heat	No evidence of outer damage $\Delta L/L$ within $\pm 5\%$ $\Delta Q/Q$ within $\pm 10\%$	Immerse in the solder at $260\pm 5^{\circ}\text{C}$ for 10 ± 1 seconds
Solderability	95% of the terminal should be covered with new solder	Immerse in the solder at $230\pm 5^{\circ}\text{C}$ for 3 ± 0.5 seconds
Resistance to solvent	No damage and marking must remain legible	Accordance with MIL-STD-202F Method 215

7-3 Environmental Characteristics

Item	Requirement	Test Methods
Low temperature storage	No evidence of damage $\Delta L/L$ within $\pm 5\%$ $\Delta Q/Q$ within $\pm 10\%$	Store at $-40 \pm 2^\circ\text{C}$, for 1000 hours
High temperature storage	No evidence of damage $\Delta L/L$ within $\pm 5\%$ $\Delta Q/Q$ within $\pm 10\%$	Store at $+125 \pm 2^\circ\text{C}$, for 1000 hours
Moisture endurance	No evidence of damage $\Delta L/L$ within $\pm 5\%$ $\Delta Q/Q$ within $\pm 10\%$	Store at $40 \pm 2^\circ\text{C}$, 90~95% RH for 1000 hours
Load life	No evidence of damage $\Delta L/L$ within $\pm 5\%$ $\Delta Q/Q$ within $\pm 10\%$	Biased to full rated current at $+125^\circ\text{C}$ for 1000 hours
High temperature High Humidity	No evidence of damage $\Delta L/L$ within $\pm 5\%$ $\Delta Q/Q$ within $\pm 10\%$	Biased to 10% rated current at $+85^\circ\text{C}$, 85% RH for 1000 hours
Thermal shock	No evidence of damage $\Delta L/L$ within $\pm 5\%$ $\Delta Q/Q$ within $\pm 10\%$	100 cycles between $-40^\circ\text{C}/\text{hour}$ and $+125^\circ\text{C}/\text{hour}$
Temperature characteristics	$\Delta L/L$ within $\pm 5\%$	$\Delta L/L$ to be measured at the temperature of between -40°C and $+125^\circ\text{C}$ as based on the inductance at 20°C

Unless otherwise specified, measurements shall be performed within 2 hours after leaving test samples for more than one hour at the normal temperature and at the normal humidity.

8. Packaging

8-1 Taping

The tapes for taping shall be embossed carrier tapes of 8 mm width and 4 mm pitches. The standard quantity per reel shall be 2,000 pieces.

(1) Dimensions of Carrier Tape

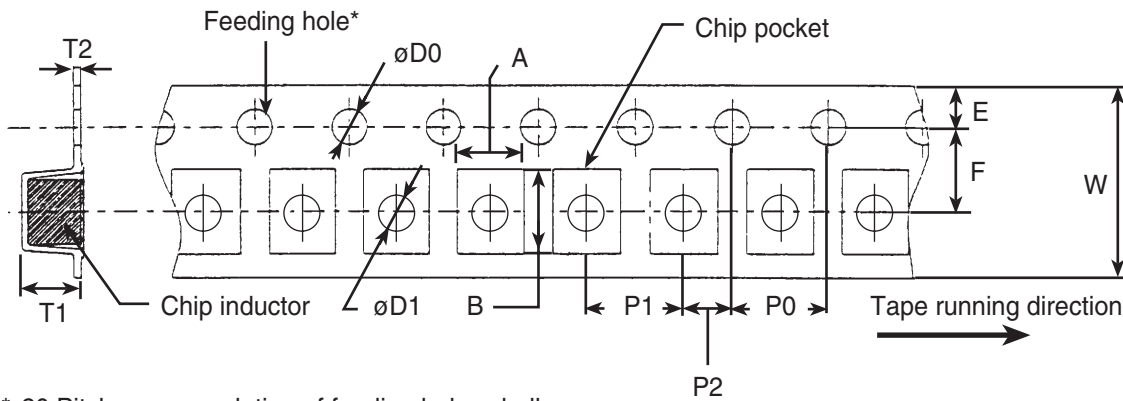

* 20 Pitches accumulation of feeding holes shall be 80 ± 0.15 mm.
Top tape peeling strength: 0.1N ~ 0.7N

Dimensions in inches (mm)

Series	A	B	W	E	F	T1
3N3~R39	0.062 ± 0.003 (1.60 ± 0.1)	0.087 ± 0.003 (2.22 ± 0.1)	0.314 ± 0.007 (8.0 ± 0.2)	0.068 ± 0.003 (1.75 ± 0.1)	0.137 ± 0.001 (3.5 ± 0.05)	0.059 ± 0.003 (1.5 ± 0.1)
R47~R82	0.066 ± 0.003 (1.7 ± 0.1)	0.086 ± 0.003 (2.20 ± 0.1)				0.057 ± 0.003 (1.45 ± 0.1)

Dimensions in inches (mm)

Series	T2	P0	P1	P2	øD0	øD1
3N3~R39	0.009 ± 0.001 (0.25 ± 0.05)	0.157 ± 0.003 (4.0 ± 0.1)	0.157 ± 0.003 (4.0 ± 0.1)	0.078 ± 0.001 (2.0 ± 0.05)	$0.059 \pm \begin{matrix} 0.003 \\ 0 \\ 0 \end{matrix}$ (1.5 ± $\begin{matrix} 0.1 \\ 0 \\ 0 \end{matrix}$)	$0.039 \pm \begin{matrix} 0.007 \\ 0 \\ 0 \end{matrix}$ (1.0 ± $\begin{matrix} 0.2 \\ 0 \\ 0 \end{matrix}$)
R47~R82						$0.039 \pm \begin{matrix} 0.007 \\ 0 \\ 0 \end{matrix}$ (1.0 ± $\begin{matrix} 0.2 \\ 0 \\ 0 \end{matrix}$)

(2) Taped Configurations (conforming to EIA-481 standard)

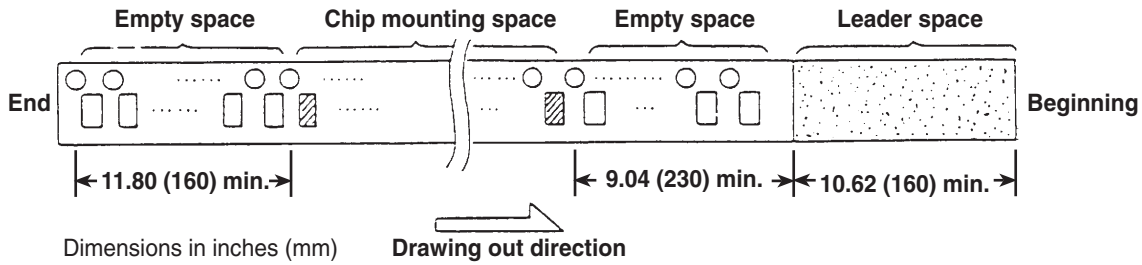

(3) Reel Dimensions and Indication

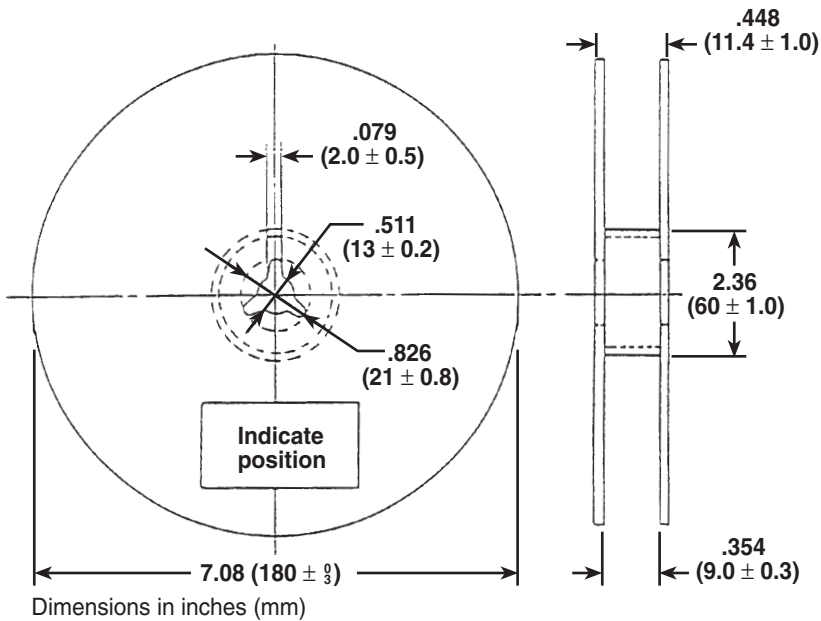

The following items shall be indicated on the reel.

- Type (KQ 0805 TE)
- Nominal inductance and tolerance
- Quantity
- Production lot number
- Manufacturer's name or trade mark

9. General Information

(1) Storage

Chip inductors shall not be stored under high temperature and high humidity conditions. Especially, do not store taping where they are exposed to heat or direct sunlight. Otherwise, the packing material may be deformed, causing problems during mounting.

(2) Mounting

Placement force should not be excessive.

(3) Soldering

Flow soldering should be done at 260°C for less than 10 seconds. Reflow soldering should be done at 240°C for less than 30 seconds. When using a soldering iron, temperature shall not exceed 350°C and within 3 seconds. Soldering iron time of each electrode shall be allowed only one time. After soldering, chip inductors shall not be stressed excessively.

(4) Cleaning

There is no problem using organic solvents. Since this chip inductor is a coil of ultra-fine wire, it is susceptible to vibration. If an ultrasonic cleaning unit is used for cleaning, check for any possibility of problem generation before practical use since such cleaning units considerably differ in vibration level and mode.

Although the conditions differ depending on the printed board size, ultrasonic cleaning is generally used in the conditions described below as examples.

Power: Within 20 W/L

Cleaning times: Within 5 minutes

(5) Pattern design

The land pattern is recommended as follows.

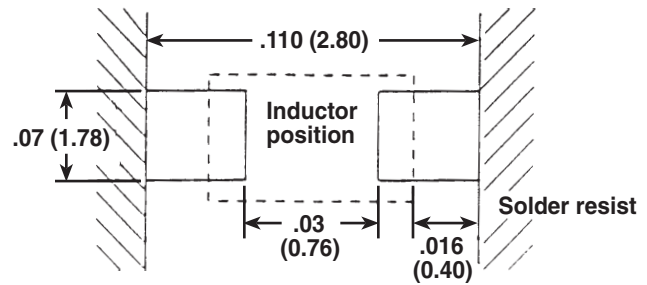

Dimensions in inches (mm)