

**PLEASE CHECK WWW.MOLEX.COM FOR LATEST PART INFORMATION**

**Part Number:** **0192120003**  
**Status:** **Active**  
**Overview:** [wire\\_pins](#)  
**Description:** InsulKrimp™ Wire Pin Terminal for 22-18 AWG Wire

**Documents:**

[Drawing \(PDF\)](#) [RoHS Certificate of Compliance \(PDF\)](#)

**Agency Certification**

CSA LR18689  
 UL E32244

**General**

Product Family Crimp Terminals  
 Series [19212](#)  
 Comments Pin Length 9.40mm (.370")  
 Crimp Quality Equipment Yes  
 MolexKits Yes  
 Overview [wire\\_pins](#)  
 Product Name Wire Pin

**Physical**

Flammability 94V-2  
 Gender Male  
 Material - Metal Copper  
 Material - Plating Mating Tin  
 Packaging Type Bag  
 Plating min: Mating (µin) 39  
 Plating min: Mating (µm) 1.00  
 Termination Interface: Style Crimp or Compression  
 Wire Insulation Diameter 3.68mm (.145") max.  
 Wire Size AWG 18, 19, 20, 22  
 Wire Size mm² N/A

**Material Info**

Old Part Number WP-2218X

**Reference - Drawing Numbers**

Sales Drawing SD-19212-001

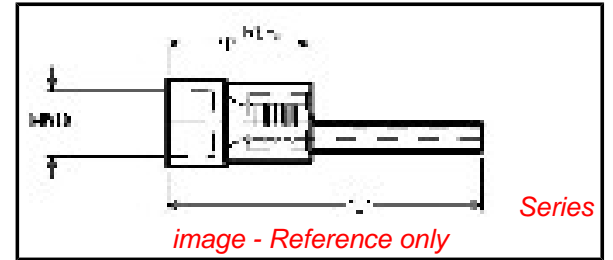

**EU RoHS**

**ELV and RoHS  
 Compliant**

**REACH SVHC**

Not Reviewed

**Halogen-Free**

**Status**

**Not Reviewed**

**China RoHS**



**Need more information on product  
 environmental compliance?**

Email [productcompliance@molex.com](mailto:productcompliance@molex.com)  
 For a multiple part number RoHS Certificate of  
 Compliance, [click here](#)

Please visit the [Contact Us](#) section for any  
 non-product compliance questions.

**Search Parts in this Series**

[19212Series](#)

**Application Tooling | FAQ**

*Tooling specifications and manuals are  
 found by selecting the products below.  
 Crimp Height Specifications are then  
 contained in the Application Tooling  
 Specification document.*

**Global**

Description	Product #
Hand Crimp Tool	<a href="#">0640010100</a>
Hand Crimp Tool	<a href="#">0640010300</a>
Hand Crimp Tool	<a href="#">0640011200</a>
Crimp Head for the AT-200™ Pneumatic Hand Tool	<a href="#">0640050100</a>
Crimp Head for the AT-200™ Pneumatic Hand Tool	<a href="#">0640050300</a>
Crimp Head for the AT-200™ Pneumatic Hand Tool	<a href="#">0640051200</a>

10	9	8	7	6	5	4	3	2			
MATERIAL NO. LOOSE PIECE	ENGINEERING NO. LOOSE PIECE	MATERIAL NO. ON TAPE	ENGINEERING NO. ON TAPE	WIRE SIZE	INSULATOR COLOR	ID MINIMUM	L MAXIMUM	P (A1) MINIMUM	D ±.01/0.25	MWID	B MAX (A1)
192120003	WP-2218X	192120004	WP-2218XT	22-18 AWG	RED	.055/1.40	.93/23.6	.35/8.9	.078/1.98	.145/3.68	.41/10.4
192120005	WP-2614X	192120006	WP-2614XT	16-14 AWG	BLUE	.081/2.06 (A1)	.93/23.6	.35/8.9	.078/1.98	.175/4.44	.41/10.4
192120001	WP-2210X	192120002	WP-2210XT	12-10 AWG	YELLOW	.126/3.20	1.12/28.4	.41/10.4	.107/2.72	.250/6.35	.56/14.2

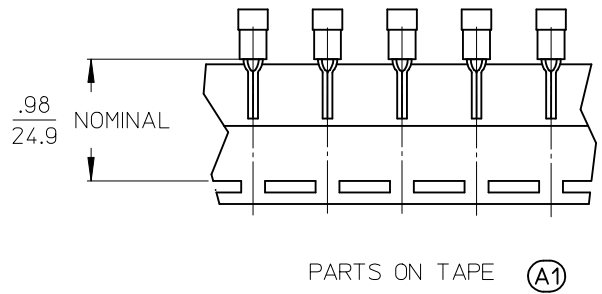
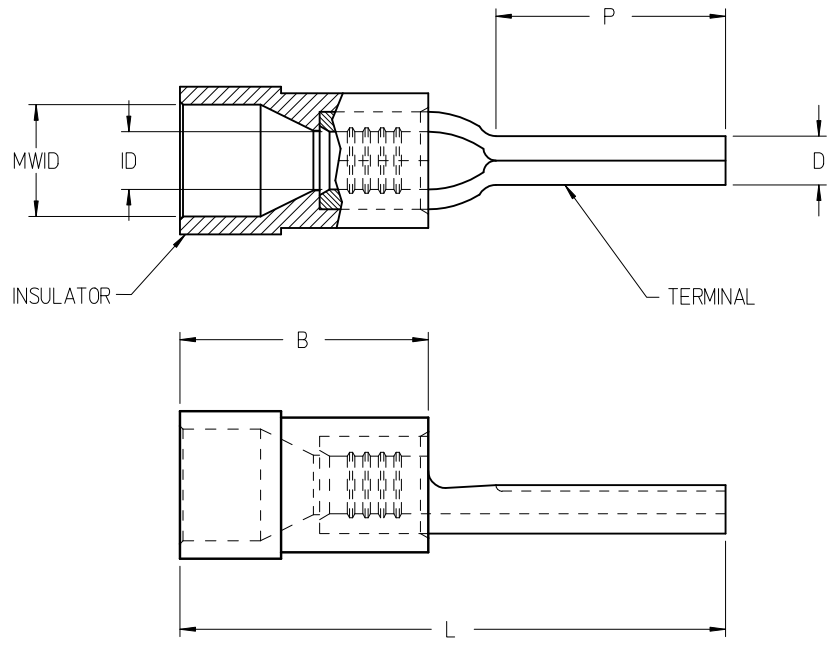

NOTES:

1. TERMINAL MATERIAL: COPPER
2. TERMINAL FINISH: TIN PLATED
3. INSULATOR MATERIAL: PVC
4. MWID = MAXIMUM WIRE INSULATION DIAMETER.
5. PARTS ARE ROHS COMPLIANT.

CORRECT TOLERANCES EC NO: WNA2009-0437 DRW: HETHRODAHL 2010/02/19 CHKD: JMACNEIL 2010/03/01 APPR: JMACNEIL 2010/03/18	QUALITY SYMBOLS	GENERAL TOLERANCES (UNLESS SPECIFIED)	DIMENSION STYLE	SCALE	DESIGN UNITS	THIRD ANGLE PROJECTION
	▽=0	mm INCH	IN/MM	5:1	INCH	
	▽=0	4 PLACES ± --- ± ---	DRAWN BY DATE	TITLE		
		3 PLACES ± --- ± ---	EMF 1992/10/08	WIRE PIN TERMINAL, INSULKRIMP		
		2 PLACES ± --- ± ---	CHECKED BY DATE	MOLEX INCORPORATED		
	1 PLACE ± --- ± ---	JM 1992/10/08	SD-19212-001			
	ANGULAR ± ---°	APPROVED BY DATE	DOCUMENT NO.			
		JMACNEIL 2010/03/18	SHEET NO.			
		MATERIAL NO.	1 OF 1			
		SEE CHART	THIS DRAWING CONTAINS INFORMATION THAT IS PROPRIETARY TO MOLEX INCORPORATED AND SHOULD NOT BE USED WITHOUT WRITTEN PERMISSION			
		SIZE B				