

isc Silicon NPN Darlington Power Transistor

BU810

DESCRIPTION

- Collector-Emitter Sustaining Voltage-
: $V_{CEO(SUS)} = 400V(\text{Min})$
- High Switching Speed

APPLICATIONS

- Designed for use in high frequency and efficiency converters, switching regulators and motor control.

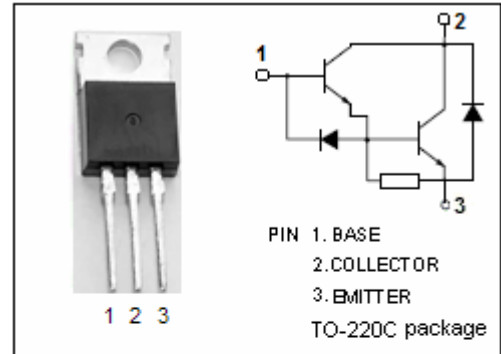

ABSOLUTE MAXIMUM RATINGS($T_a=25^\circ\text{C}$)

SYMBOL	PARAMETER	VALUE	UNIT
V_{CBO}	Collector-Base Voltage	600	V
V_{CEO}	Collector-Emitter Voltage	400	V
V_{EBO}	Emitter-Base Voltage	5	V
I_C	Collector Current-Continuous	7	A
I_{CM}	Collector Current-Peak	10	A
I_B	Base Current	2	A
P_C	Collector Power Dissipation @ $T_C=25^\circ\text{C}$	75	W
T_J	Junction Temperature	150	$^\circ\text{C}$
T_{stg}	Storage Temperature Range	-65~150	$^\circ\text{C}$

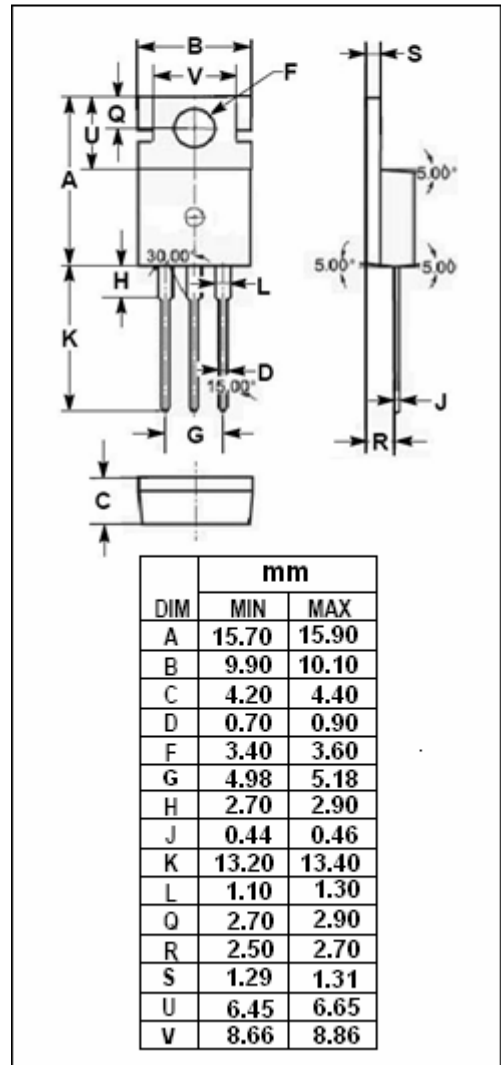

THERMAL CHARACTERISTICS

SYMBOL	PARAMETER	MAX	UNIT
$R_{th\ j-c}$	Thermal Resistance, Junction to Case	1.66	$^\circ\text{C}/\text{W}$

isc Silicon NPN Darlington Power Transistor**BU810****ELECTRICAL CHARACTERISTICS** $T_C=25^{\circ}\text{C}$ unless otherwise specified

SYMBOL	PARAMETER	CONDITIONS	MIN	TYP.	MAX	UNIT
$V_{CE(SUS)}$	Collector-Emitter Sustaining Voltage	$I_C=100\text{mA}; I_B=0$	400			V
$V_{CE(sat)-1}$	Collector-Emitter Saturation Voltage	$I_C=2\text{A}; I_B=20\text{mA}$			2	V
$V_{CE(sat)-2}$	Collector-Emitter Saturation Voltage	$I_C=4\text{A}; I_B=0.2\text{A}$			2.5	V
$V_{CE(sat)-3}$	Collector-Emitter Saturation Voltage	$I_C=7\text{A}; I_B=0.7\text{A}$			3	V
$V_{BE(sat)-1}$	Base-Emitter Saturation Voltage	$I_C=2\text{A}; I_B=20\text{mA}$			2.2	V
$V_{BE(sat)-2}$	Base-Emitter Saturation Voltage	$I_C=4\text{A}; I_B=0.2\text{A}$			3	V
I_{CES}	Collector Cutoff Current	$V_{CE}=600\text{V}; V_{BE}=0$			0.2	mA
I_{CEO}	Collector Cutoff Current	$V_{CE}=400\text{V}; I_B=0$			1	mA
I_{EBO}	Emitter Cutoff Current	$V_{EB}=5\text{V}; I_C=0$			150	mA
V_{ECF}	C-E Diode Forward Voltage	$I_F=7\text{A}$			3	V

Switching Times, Resistive Load

t_{on}	Turn-On Time	$I_C=2\text{A}; I_{B1}=20\text{mA}; V_{BE(off)}=-5\text{V}$ $V_{Clamp}=250\text{V}$			0.6	μs
t_s	Storage Time				1.5	μs
t_f	Fall Time				0.5	μs