

COic5130A Specifications

t = 0 to 10, 320Mbs,

Programmable Reed-Solomon

Error Correction Encoder and Decoder

For information on separate encoder refer to the COic5127A data sheet.

For information on separate decoder refer to the COic5128A data sheet.



Preliminary Device Specification

Introduction

The COic5130A contains both a high data rate programmable Reed-Solomon encoder and a separate decoder that will process blocks of up to 255 eight bit symbols to provide corrections (T) of up to 10 errors per code block at data rates up to 320 Mbs. The encoder output code block will contain the unaltered original data symbols followed by the generated parity symbols. The decoder input will contain the received data symbols including errors that may be introduced during transmission. Decoder output will be a completely corrected block or will be marked as non-correctable and the block will be outputted as received without any changes.

The encoder and decoder can be operated independent of each other. Either or both may active at one time. As the devices have separate clocks, the encoder and decoder may operate at different data rates.

The 128-pin mqfp device is manufactured using an 0.5micron CMOS technology by a ISO 9000 certified facility. This part is functionally compatible with the COic5125A, COic5126A, COic5127A and COic5128A and also the AMPEX 1295125-01 and 1295126, but includes features not found in the Ampex devices.



Encoder Functional Description

The COic5130A contains an encoder that will provide (N, N-r) Reed-Solomon forward error correction encoding of blocks of eight bit symbols. The number of parity symbols (r) may be from 0 to 20, 0 in Pass Through Mode, and the number of symbols in a block (N) from r+1 to 255. At the decoder two parity bytes will be used for each untagged symbol error correction and one parity byte used for a location identified error (erasure) correction. This will provide correction of up to 10 errors (E) or up to 20 erasures (e) or a combination as long as $2E + e \leq r$.

The encoder can encode data at rates from 0 to 40 million symbols per second (320 Mbs) These devices implement the primitive polynomial $Px = x^8 + x^4 + x^3 + x^2 + x^0$ and the generator polynomial

$$G(x) = \prod_{i=0}^{r-1} (x - \mu^i)$$

which are compatible with SMPTE D-1/D-2, ANSI ID1/ID2, MIL-STD-2179A, DVB, DDS, DAVIC, and DSL standards.

Controls are provided to :

1. tri-state the output data bus
2. disable the input data
3. select the output data source (input data bus or parity generator)

Encoder Functional Block Diagram

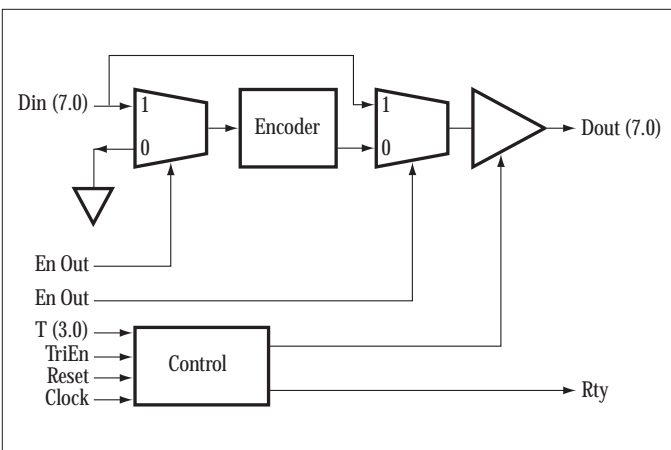

Encoder Features

- Supports 8 bit symbol Reed-Solomon codes (N, N- r) with $0 < r < 20$ and $r+1 < N < 255$, N= symbols per block including parity, r = number of parity bytes (NOTE: r is often called 2t)
- Encoding rates from 0 to 320 Mbs with 0 to 40 Mhz symbol clock
- Implements SMPTE D-1/D-2 Digital Video Standards, DVBS Digital Video, ANSI ID-1/ID-2, and Mil -STD-2179A coding polynomials

- Requires only one (byte) clock. Input and output data are at one byte per symbol clock for each the encoder and decoder
- Code provides choice of 0 to 20 parity bytes per block
- Provides Pass Through (no parity) mode switching on the fly
- Processing latency of only 3 symbol clocks
- Allows code rate changes on the fly
- ISO 9000 certified manufacturing
- 128-pin metal quad flat pack
- Vdd 4.5 to 5.5 volts operation
- - 40 to + 85 degrees C operation

Encoder Initialization

Before operations the encoder must be initialized to define the number of parity symbols (r).

To initialize the binary value of r/2 (0 to 10) is placed in TA0 - TA3 (TA0 is least significant) while Reset and EnInA are held low for four symbol clock periods. Reset is then brought and held high for two symbol clock periods. The inputs on TA0 - TA3 can then be released and the section can start normal operation.

Any TAx pin that is not used must be held low or connected to ground.

Encoding

To encode a block of symbols the enable in line (EnInA) and enable out line (EnOutA) are brought high coincident with the leading edge of first data symbol clock in a new block and remain high until all of the data symbols are clocked into the encoder section and k-3 symbols out onto the Dout bus. There is a processing latency (delay) of three clock cycles between the data in (DinA) and the data out (DoutA). The data ready signal (RdyA) is EnInA delayed by three clock cycles.

At the leading edge of the clockA pulse after the last data symbol has been placed into the encoder, EnInA and EnOutA are brought low. This will fill the parity generator with zeros. EnInA and EnOutA are held low for (r) clock cycles which inputs zeros into the encoder while outputting the parity code symbols which are appended to the data symbols to form the output data stream. After at least r clock cycles EnInA and EnOutA are brought high to start the next block.

The output data bus (DoutA) may be put into a high impedance state by bringing the TriEnA high. This will not effect the operation of the encoder except to disable the output bus.

When the input enable (EnInA) is low, zeros will be clocked into the encoder input. This can be used to prevent spurious data from being encoded.

The number of data symbols (k) of succeeding blocks can be changed as desired at any time. This will change the code rate for the blocks, but to change the correction power (r) the section must be re-initialized. This can also be done at any time, but any blocks in process at that time will be lost.

Encoder Duplex Operation

Half Duplex operation can be achieved on a single bi-directional channel at a maximum transmission rate equal to one half of the symbol clock. Allowing for transmission and circuit switching delays, data can be switched from the unit encoder to the decoder on any symbol boundary. External data switching and control circuits will be required to control data flow and device enables.

Full duplex at full clock rate can be implemented but requires two data carriers or echo cancellation.

Encoder Pass Through Mode

Any number of symbols can be passed through the encoder without any encoding if the Enable In (EnInA) is held high and enable out (EnOutA) is held low while the symbols are clocked into the section. This will allow the maximum data transfer rate, but will not provide any error correction ($t=0$). To end pass through mode operation EnInA must be brought high, which will start the encoding process. This must be at the beginning of a block for correct operations. Pass through mode may be invoked at any time but any blocks in process when this mode is started will not be encoded properly and will not be able to be decoded.

Decoder Functional Description

COic5130A includes a high data rate programmable Forward Error Correction devices that can decode Reed-Solomon code blocks of up to 255 eight bit data symbols. It provides corrections of up to 10 symbol errors per block at data rates up to 320 Mbs. Blocks with more errors than are correctable are so flagged with data outputted as received (no corrections). Note: blocks must contain at least 8 parity symbols, except when operating in bypass mode.

The decoder input code block will contain the transmitted data and parity symbols, including corruption by channel noise (errors). A symbol error is corrected the same regardless of the number of incorrect bits in the symbol and decoding time is the same regardless of the number of errors in a block. Decoder output data will be corrected data plus corrected parity or block error data. Error location and correction data is also provided. No clock other than the data clock is required. Input and output are one byte per clock cycle.

COic5130A uses the primitive polynomial $P_x = x^8 + x^4 + x^3 + x^2 + x_0$ which complies with SMPTE D-1 / D-2 Digital Video Standards, DVB, DBS, DAVIC, DSL, ANSI ID-1 / ID-2, and MIL STD 2179A. The COic5130A is functionally compatible with the COic5127 encoder and

COic5128 decoder as well as the T=5 AMPEX 1295126-01. It includes features not found in that device, and using $r = 20$ corrects up to 10 errors per block.

$$\text{Devices use the generator polynomial : } G(x) = \prod_{i=0}^{r-1} (x - \mu^i)$$

Decoder Functional Block Diagram

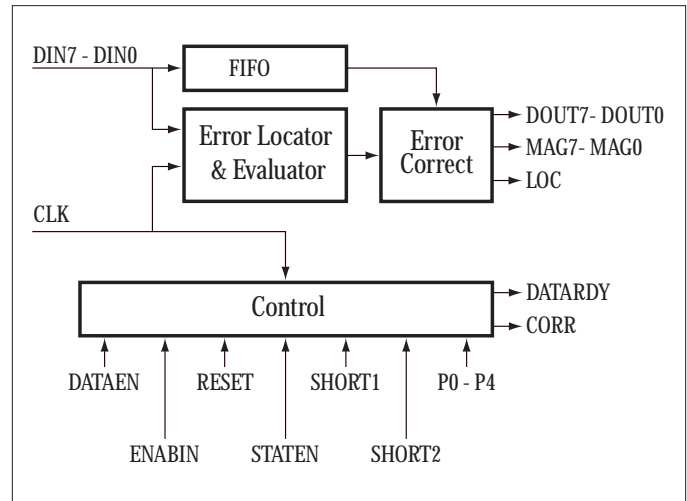

Decoder Features

- Supports 8 bit symbol Reed Solomon codes ($N, N-r$) with $0 < r < 20$ and $N < 255$, $N =$ symbols per block including parity, $r =$ number of parity symbols (Note: r is often called $2t$)
- Corrects up to 10 errors per block
- COic5128A has 3 selectable latencies:
 - Default (Amplex / AHA) = $2N + 5r + 33$ clock cycles with a minimum block length of $5r + 15$
 - Latency 1 = $2N + 2r + 13$ clock cycles with a minimum block length of $2r + 13$
 - Latency 2 = $3N/2 + 3r/2 + 15$ clock cycles with a minimum block length of $3r/2 + 15$
- Contains complete decoder device. No external memory or control required after initialization
- Data rates up to 40 MBS (320 Mbs) with 0 to 40 Mhz symbol clock
- End of Block flag eases applications
- Input and output data are at the identical rate and operates on data clock only
- Provides Pass Through Mode (no correction) switching on-the-fly
- Latency is constant regardless of error patterns
- Allows code rate change (less data, same parity) on-the-fly

- Provides complete error location and correction information
- Flags uncorrectable blocks
- 4.5 to 5.5 volt operation
- -40 to + 85 degrees C operation range (extended range available)
- ISO 9000 certified manufacturing

Decoder Functional Description

The device contains a decoder that will provide (N,N-r) Reed-Solomon forward error correction decoding of blocks of eight bit symbols. The number of parity symbols (r) may be from 8 to 20, 0 in Pass Through Mode, and the number of symbols in a block (N) up to 255. Two parity bytes will be used for each symbol error correction. This device will provide correction of up to 10 symbol errors (E) as long as $2E \leq r$. It will provide the number of corrections made in each block. Symbol errors are processed the same regardless of the number of incorrect bits in the symbol. Processing latency is the same regardless of the number of errors, including zero, in a block. The device can decode at data rates from 0 to 40 million symbols per second (320 Mbs) and two or more devices can be used together (see Application Brief for Reed-Solomon FEC) to process data at higher rates.

Encoder Initialization

Before operations the device must be initialized to define N, r, P (the number of parity symbols that can be used (decoded) before a block is determined uncorrectable) and to set the block error information report (status) output. A two step process is used.

Step One: Set the level of OptLn to the desired level and maintain throughout all operations. While the binary value of P is held on the P control bus, Reset and DataEn are held low for at least four symbol clock cycles and then Reset is brought high and held high for at least two more symbol clock cycles. At the same time the StatEn line is held high if the decoder block error information bytes (status) output are desired and low if not. Note that the decoder will output corrected parity bytes in the space formerly used by parity which are not used by block error information (status) bytes. Symbols of any value can be used for this step.

Step Two: With Reset high a normal block processing procedure is used to set up values of N, r, and k (N-r). The Enabln is brought high with the first data symbol and held high throughout the decoding session. Also at the beginning of the block DataEn is brought high at the leading edge of the first symbol clock pulse and held high while the data symbols are being clocked into the device, that is N-r symbol clock pluses. DataEn is brought low with the first parity symbol and held low for r symbol clock cycles while the parity symbols are clocked in. DataEn, going high again marks the end of parity and the start of the next block. Reset will remain high throughout step 2 and normal use until a new reset cycle is desired. This step will set up the device timing for all following blocks until the device is reinitialized or an alternate length block with fewer data symbols (see Alternate Block Length) is used. A

regular data block may be used for this step but to prevent possible loss of data a block using dummy symbols of any value is recommended.

Selecting the value of P

The value of P determines the number of parity bytes that can be used (decoded) before a block is flagged as uncorrectable. The decoder will always use all of the parity bytes available to correct a block regardless of the value of P, which is usually set equal to r (the number of parity bytes) but P can be less or more than r.

1. If P equals r the device will properly correct all blocks where $2E \leq r$ and mark all other blocks as uncorrectable. This option is almost always used.
2. If P is less than r the device will use all of the parity bytes to correct the block but will mark corrected blocks as uncorrected if $P < 2E < r$. In this case the error status bytes must be checked to determine if correction was actually achieved. This feature can be used to detect more errors than can be corrected, but must be used with care.
3. If P is more than r normal correction will take place but the device will not provide uncorrectable block flags and may pass on to the output unflagged uncorrected data blocks. THIS SETTING HAS NO VALUE AND SHOULD NOT BE USED.
4. If P is more than 20 the decoder will pass all information directly to the data output without any corrections. THIS SETTING HAS NO VALUE AND SHOULD NOT BE USED.

The value of P may be changed at any time, but any blocks in process at the time of the change may not be properly flagged if uncorrectable.

Minimum Block Lengths

Minimum block lengths and latency are a function of the number of parity bytes used in a code. OptLn must be set at the start of initialization and held at the correct level throughout operations. The device must repeat Initialization if OptLn is to be changed

The COic5130A allows three different equations to determine the minimum block lengths. When pin 16 is low and pin 9 LOW or NC the default equation is Minimum Block Length = $5r + 15$ bytes. When pin 9 is held at High and pin 16 is low level Latency1 is invoked and the minimum block length equation is changed to $(2r + 13)$ bytes. If pin 16 is high Latency 2 is invoked and the minimum block length is $3r/2 + 15$ regardless of the level of pin 9.

Decoder Latency

The time that is required for the data to flow through the device is called latency and is measured in symbol clock cycles. The devices can be operated with any of three latencies, under the control of OpLan1, pin 9 and OpLan2, pin 16. Latencies are a function of the block length and correction level, but unaffected by error patterns. The default latency (pin 9 and 16 both low) is equal to $2N + 5r + 33$ symbol clock cycles,

which is compatible with the Ampex 1295126-01 device. When pin 9 is held to High level and pin 16 is low Latency 1 is invoked and the equation is changed to $2N + 2r + 13$ symbol clock cycles. Latency 2 is invoked if pin 16 is high regardless of the level of pin 9 and the equation is $3n/2 + 3r/2 + 15$. Effects of optional shorter latency and minimum code length (OptLn) : The combination of the shorter code and latency can result in considerable increase in effective data transfer. In most new designs the Latency1 or Latency 2 option will provide the best operations.

Example: If a desired code is (64,48) $r=16$, the default minimum block length ($5r + 33$) is 95 bytes which requires 31 " filler " bytes to be inserted in each block., a loss of over 33 % of the channel effectiveness.

The latency ($2N+5r+33$) is 313 clock cycles. With OptLn2 invoked the minimum block length is 39 bytes , which does not require any filler bytes so there is no loss of channel effectiveness. The latency is 135 clock cycles.

Decoding

After the COic5130A is initialized it can begin decoding incoming blocks. It is a good idea, but not absolutely necessary, to pass at least as many dummy symbols as the latency through the device before actual data is used in order to clear out any spurious information in the unit. Although it is not recommended, block of data can be used to initialize the device can be made up of valid data, if step one has been completed.

To decode, the Enabln is brought high and held high throughout the decoding secession. At the beginning of a code block DataEn is brought high at the leading edge of the first symbol clock pulse and held high while the data symbols are being clocked into the device, that is N-r symbol clock pluses. DataEn is brought low with the first parity symbol and held low for r symbol clock cycles while the parity symbols are clocked into the decoder. DataEn,s going highagain marks the end of parity and the start of the next block.

The first data symbol is placed on the Dout bus, the DatRdy line will go high and the unit will begin to output data symbols when the number of symbol clocks required for processing latency are complete. At the end of N-r symbols the DatRdy line goes low and parity symbols are outputted

Correct

Correct pin --- goes high as the block starts being outputted if the block contains corrected symbols or low if the block is outputted as it was received due to either 0 or more than r errors in the block.

UnCorr

If the block cannot be corrected UnCorr, pin --- will go to the high level. This will occur as the block being processed starts to be outputted.

StatEN

If StatEn has been set high the first two parity bytes will be replaced with error information. Byte 1 will show FXXXXXXX and Byte 2 will show FXXTTTTT where:

F = block Not Correctable if high, block was Corrected if low.

EEEE = Erasure count will be 0.

TTTTT = Total number of corrections made in the block.

If the block was not correctable (F bit is high) E and T values will be meaningless. If StatEn is low all of the corrected parity symbols will be clocked out of the decoder.

Decoder Error Information Output

In order to help optimize the application ECC function, detailed error information for each block is also available while the decoder data output is in process. It is not necessary to use this information for proper operation the part.

If the symbol being outputted from the decoder has been corrected ErLoc (pin 24) will go high. The pattern used to correct that symbol will appear on CMag 0 -CMag7 pins at the same time. Note that the error is actually the logical inverse of the correction. (The user must provide external storage and processing of this information as the COic5130 does not store these error location or correction information outputs. If the decoder detects more than $r/2$ errors ErLoc will remain low throughout the block as no changes will be made. The UnCorr line or Status bytes must be monitored to flag this condition.

Decoder Pass Through Mode ($r=0$)

Any number of symbols can be passed through the decoder without any changes (corrections) if the Enable In (Enabln) is held low while symbols are clocked into the device. The input symbols, data and parity if any, will be passed unchanged to the output (Dout) after the number of symbol clocks needed for processing latency. In this mode there will normally not be any parity symbols. That will allow transfer of data symbols at the maximum rate, but will not provide any error correction ($t=0$).

To end Pass Through Mode operation Enabln must be brought high, which will start the decoding process. This must be at the beginning of a block for correct operations. Pass Through Mode may be invoked at any time but any blocks in process when this mode is started will not be decoded properly.

EnOBk

When the last byte of a block is outputted EnOBK pin 22 will go to the high level for one clock period.

Encoder Output Timing

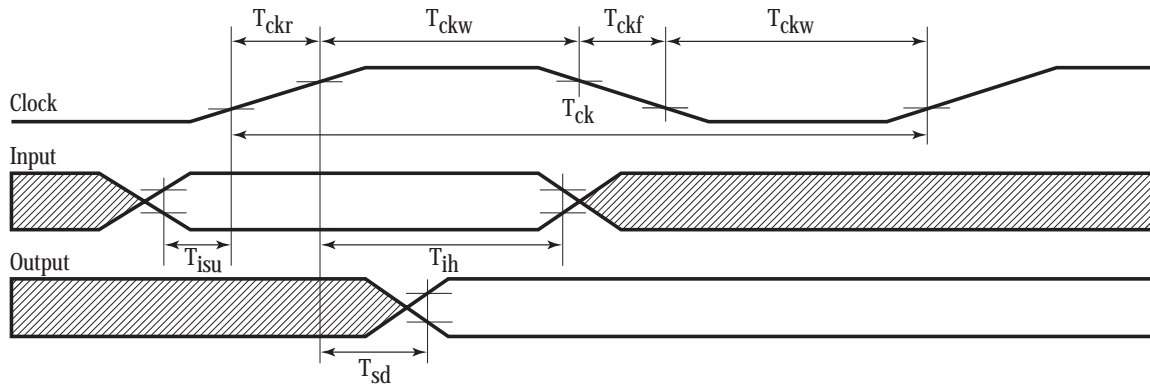

Encoder Initialization

Before operation the encoder must be initialized to define the number of parity symbols (r).

To initialize the binary value of $r/2$, (0 to 10) is placed in **T0 – T3** (**T0** is least significant) while **RESET** and **ENIN** are held low for four symbol clock periods. **RESET** is then brought high for two symbol clock periods. The inputs on **T0 – T3** can then be released and the encoder can start normal operation. Any **TX** pin that is not used must be held low or connected to ground.

Decoder Output Timing

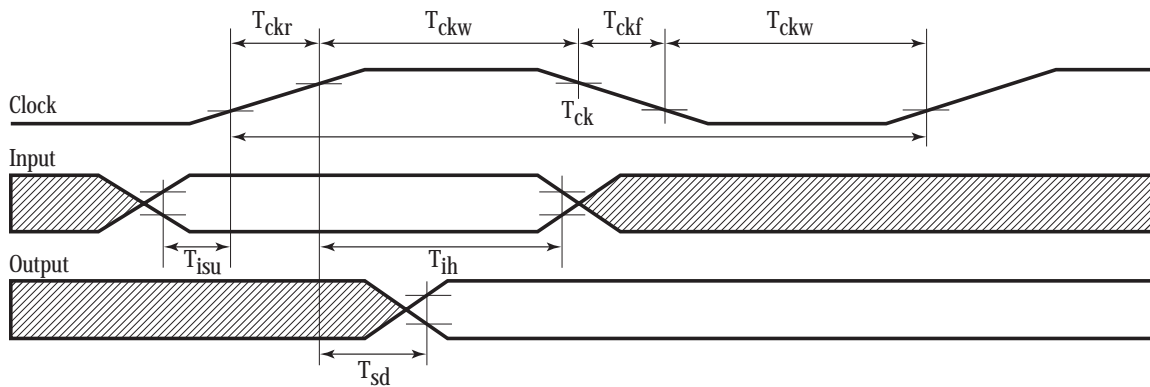

Decoder Initialization

Certain architectural and mathematical properties of this device are not hard wired and must be set up during the initialization control sequence. These properties include:

1. The overall message block length (N)
2. The number of data bytes (K)
3. The total number of check bytes (R)
4. The number of check bytes allocated for correction only (P)
5. Whether the first check byte output positions are used for status bytes or check bytes (**STATEN**)
6. Whether to use AMPEX compatible, non-compatible, or short timing (**SHORT1**, **SHORT2**)

These properties must be initialized before normal operation can begin. There are two distinct phases of the initialization process. In phase one, the values of **P**, **STATEN** and **SHORT1** and **SHORT2** are initialized. In phase two, the first message block through the device is used to set the values of **N**, **K** and **R**.

The phase one sequence consists of at least 4 clock cycles in which **RESET** is held LOW followed by at least 2 clock cycles during which **RESET** is held HIGH. **RESET** must then remain HIGH for all subsequent operations or else an unwanted initialization sequence will ensue. The desired values of **STATEN** and **P4 - P0** must be maintained during the first phase of initialization. The desired value of **SHORT1** and **SHORT2** must be maintained during all the phases of operation of the device. **DATAEN** must be held LOW during the entire six clock sequence or unintended processing of spurious messages may occur.

Decoder Initialization Control Sequence Timing

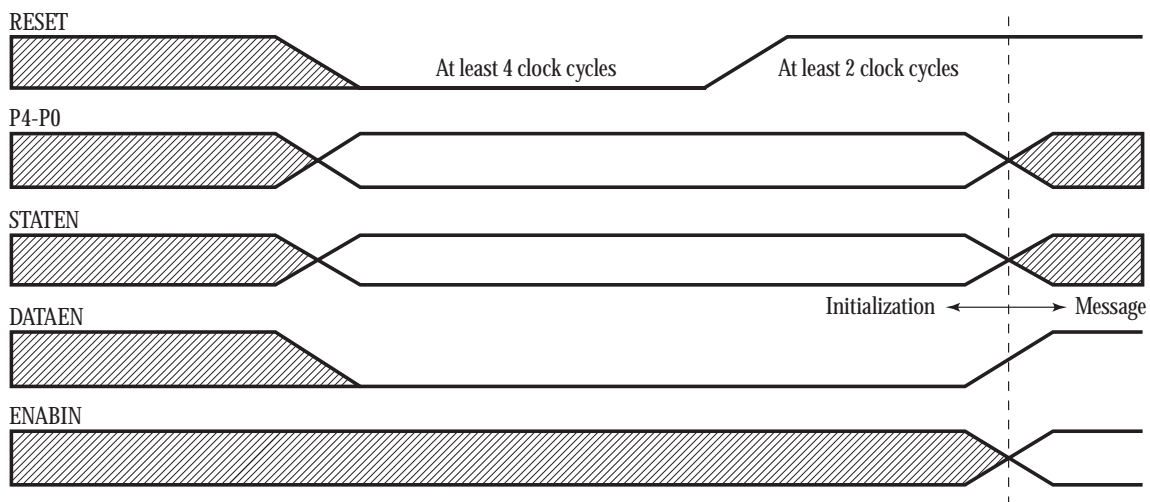

The rising edge of **DATAEN** at the end of the phase one initialization sequence marks the beginning of the first message block, which is the beginning of phase two of the initialization process. **DATAEN** has the role of initializing the parameters of **N**, **K** and **R**. **DATAEN** has a different function on all subsequent blocks until an initialization sequence is begun once again. As the first message block passes through the device, **DATAEN** is held HIGH for **K** clock cycles and then LOW for **R** clock cycles. **DATAEN** going high again marks the first byte of the second block and implies the end of the phase two initialization sequence. **DATAEN** has thus defined **R**, **K** and **N** for all subsequent blocks until another initialization sequence is performed.

Decoder Message Input Timing

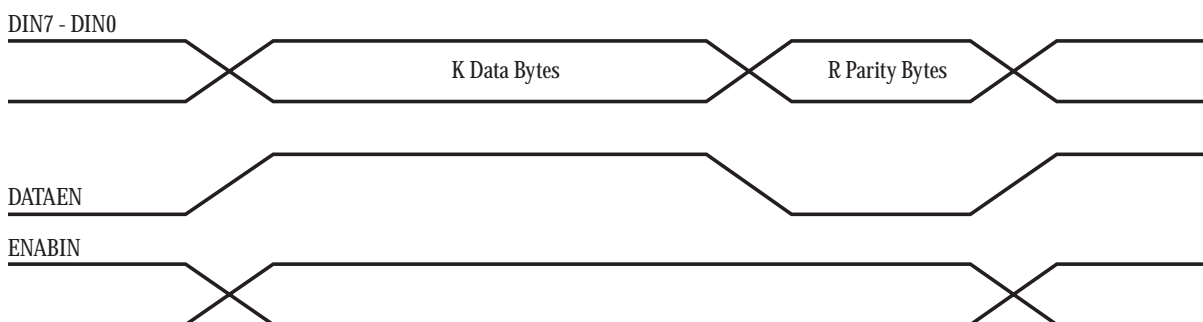

Message Decoding

During message decoding the device clocks in the encoded message block from the **DIN7 - DIN0** input bus on the rising edge of **CLK**. The device then computes polynomials for this data using a high performance Reed-Solomon coding algorithm, and then proceeds to use the calculated polynomials to correct any errors, if possible. These polynomials are a series of complex equations that will indicate not only the position of incorrect bytes but will also produce the necessary information to correct them. The timing of the decoding operation is defined

Decoder Message Output Timing

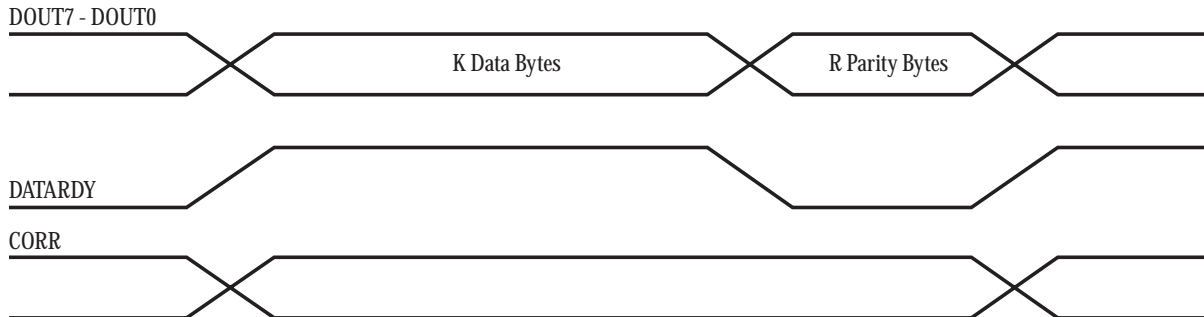

The action taken by the decoder with respect to a given message block is determined in all cases by the quantity of errors received. The device reports its action via the **CORR** output pin. If $P = R$, a HIGH output on the **CORR** pin indicates that the message block being output is correct. A LOW output indicates that a correction was not performed because there were too many errors or no errors. In situations where P has been chosen to be not equal to R , the meaning of the **UNCORR** pin is that more than $P/2$ errors have occurred.

Decoder Optional Status Bytes

The optional status bytes, that may be output at the end of the message block, indicate the number of errors encountered and may be used to determine the exact meaning of the **CORR** output when $P \neq R$. The first status byte has all of its bits set LOW except bit 7, which is the CA (correction attempted) flag. The CA flag goes LOW when $E \leq R/2$ (the message block was successfully decoded). Therefore, anytime CA is HIGH, the message block should be retransmitted since there were probably too many errors to reliably correct. Also, if $P = R$ then CA will always be LOW when the **CORR** output pin is HIGH and HIGH when **CORR** is LOW.

In the second status byte, bits 4 through 0 are a binary count of the number of errors encountered. Bit 4 is most significant. The remaining bits are always LOW.

Pinout

Table 1: Device Pinout

Pin#	Signal Name	Encoder / Decoder	Description	Signal Type
1	NC	N/A	No Connection	
2	DEC_MAG0	Decoder	Error Magnitude 0. This output indicates which bit of the current symbol output on Q7-Q0 has been corrected when LOC is HIGH. This output is indeterminate and should be ignored when LOC is low.	TTL Output
3	NC	N/A	No Connection	
4	DEC_MAG1	Decoder	Error Magnitude 1. This output indicates which bit of the current symbol output on Q7-Q0 has been corrected when LOC is HIGH. This output is indeterminate and should be ignored when LOC is low.	TTL Output
5	NC	N/A	No Connection	
6	DEC_MAG2	Decoder	Error Magnitude 2. This output indicates which bit of the current symbol output on Q7-Q0 has been corrected when LOC is HIGH. This output is indeterminate and should be ignored when LOC is low.	TTL Output
7	DEC_DOUT6	Decoder	Data output bit 6. Bit 7 is MSB.	Output
8	V _{dd}	N/A	+5 Volt Power	Power
9	DEC_DOUT5	Decoder	Data output bit 5. Bit 7 is MSB.	Output
10	NC	N/A	No Connection	
11	GND	N/A	Ground	Power
12	NC	N/A	No Connection	
13	DEC_DOUT4	Decoder	Data output bit 4. Bit 7 is MSB.	Output
14	NC	N/A	No Connection	
15	DEC_DOUT3	Decoder	Data output bit 3. Bit 7 is MSB.	Output
16	NC	N/A	No Connection	
17	V _{dd}	N/A	+5 Volt Power	Power
18	DEC_DOUT2	Decoder	Data output bit 2. Bit 7 is MSB.	Output
19	DEC_DOUT1	Decoder	Data output bit 1. Bit 7 is MSB.	Output
20	GND	N/A	Ground	Power
21	NC	N/A	No Connection	

Table 1: Device Pinout, *continued*

Pin#	Signal Name	Encoder / Decoder	Description	Signal Type
22	DEC_DOUT0	Decoder	Data output bit 0. Bit 7 is MSB.	Output
23	GND	N/A	Ground	Power
24	DEC_DATARDY	Decoder	Data Ready. Assertive HIGH. This output is held HIGH for data bytes and low check bytes.	Output
25	DEC_MAG3	Decoder	Error Magnitude 3. This output indicates which bit of the current symbol output on Q7-Q0 has been corrected when LOC is HIGH. This output is indeterminate and should be ignored when LOC is low.	TTL Output
26	NC	N/A	No Connection	
27	DEC_MAG4	Decoder	Error Magnitude 4. This output indicates which bit of the current symbol output on Q7-Q0 has been corrected when LOC is HIGH. This output is indeterminate and should be ignored when LOC is low.	TTL Output
28	NC	N/A	No Connection	
29	NC	N/A	No Connection	
30	DEC_MAG5	Decoder	Error Magnitude 5. This output indicates which bit of the current symbol output on Q7-Q0 has been corrected when LOC is HIGH. This output is indeterminate and should be ignored when LOC is low.	TTL Output
31	NC	N/A	No Connection	
32	NC	N/A	No Connection	
33	NC	N/A	No Connection	
34	NC	N/A	No Connection	
35	V _{dd}	N/A	+5 Volt Power	Power
36	ENC_TEST_SE	Encoder	Foundry Test Pin - Do not Use	
37	GND	N/A	Ground	
38	GND	N/A	Ground	
39	DEC_MAG6	Decoder	Error Magnitude 6. This output indicates which bit of the current symbol output on Q7-Q0 has been corrected when LOC is HIGH. This output is indeterminate and should be ignored when LOC is low.	TTL Output
40	DEC_STATEN	Decoder	Status Enable. Assertive HIGH. If this signal is HIGH during reset then the decoder will be programmed to output two status bytes with each message block.	Input

Table 1: Device Pinout, *continued*

Pin#	Signal Name	Encoder / Decoder	Description	Signal Type
41	NC	N/A	No Connection	
42	DEC_MAG7	Decoder	Error Magnitude 7. This output indicates which bit of the current symbol output on Q7-Q0 has been corrected when LOC is HIGH. This output is indeterminate and should be ignored when LOC is low.	TTL Output
43	V _{dd}	N/A	+5 Volt Power	Power
44	DEC_DIN7	Decoder	Decoder symbol input bit 7. Bit 7 is MSB.	Input
45	ENC_TEST_SI	Encoder	Foundry Test Pin - Do not Use	
46	DEC_DIN6	Decoder	Decoder symbol input bit 6. Bit 7 is MSB.	Input
47	GND	N/A	Ground	Power
48	ENC_DOUT6	Encoder	Encoder data output bit 6	Tristate
49	V _{dd}	N/A	+5 Volt Power	Power
50	ENC_DIN6	Encoder	Encoder data input bit 6	Input
51	DEC_TEST_SI	Decoder	Foundry Test Pin - Do not Use	
52	V _{dd}	N/A	+5 Volt Power	Power
53	DEC_DIN5	Decoder	Decoder symbol input bit 5. Bit 7 is MSB.	Input
54	ENC_DIN7	Decoder	Encoder data input bit 7	Input
55	GND	N/A	Ground	Power
56	ENC_DOUT7	Encoder	Encoder data output bit 7	Tristate
57	V _{dd}	N/A	+5 Volt Power	Power
58	GND	N/A	Ground	
59	DEC_DIN4	Decoder	Decoder symbol input bit 4. Bit 7 is MSB.	Input
60	ENC_DOUT4	Encoder	Encoder data output bit 4	Tristate
61	DEC_DIN3	Decoder	Decoder symbol input bit 3. Bit 7 is MSB.	Input
62	NC	N/A	No Connection	
63	ENC_DIN4	Encoder	Encoder data input bit 4	Input

Table 1: Device Pinout, *continued*

Pin#	Signal Name	Encoder / Decoder	Description	Signal Type
64	NC	N/A	No Connection	
65	DEC_UNCORR	Decoder	Decoder uncorrectable block. Assertive HIGH. Indicates message block contains uncorrectable errors.	Output
66	V _{dd}	N/A	+5 Volt Power	Power
67	ENC_DIN5	Encoder	Encoder data input bit 5	Input
68	ENC_DOUT5	Encoder	Encoder data output bit 5	Tristate
69	GND	N/A	Ground	Power
70	DEC_DIN2	Decoder	Decoder symbol input bit 2. Bit 7 is MSB.	Input
71	ENC_RDY	Encoder	Indicates data symbols are on the encoder ENC_DOUT bus	Output
72	DEC_DIN1	Decoder	Decoder symbol input bit 1. Bit 7 is MSB.	Input
73	ENC_ENOUT	Encoder	Enables encoder DIN bus onto the DOUT bus	Input
74	V _{dd}	N/A	+5 Volt	Power
75	ENC_ENIN	Encoder	Enable encoder DIN bus into the parity generator	Input
76	DEC_DIN0	Decoder	Decoder symbol input bit 0. Bit 7 is MSB.	Input
77	ENC_RESET	Encoder	Initializes encoder into a know state (high)	Input
78	GND	N/A	Ground	Power
79	ENC_TRIEN	Encoder	Tri-states the encoder ENC_DOUT bus drivers when HIGH	Input
80	DEC_DATEN	Decoder	Decoder data enable. Assertive HIGH. This input is used to signal the difference between data bytes and check bytes.	Input
81	DEC_ENABIN	Decoder	"Decoder enable data correction. Assertive HIGH. When this input is asserted, the device performs corrections on the message block. When CEN is low, the device does not perform corrections but continues to report status is initialized to do so."	Input
82	ENC_CLOCK	Encoder	Encoder master and symbol clock.	Input
83	ENC_TA2	Encoder	Bit 2 of the encoder T select bus	Input
84	V _{dd}	N/A	+5 Volt Power	Power
85	ENC_TA1	Encoder	Bit 1 of the encoder T select bus	Input

Table 1: Device Pinout, *continued*

Pin#	Signal Name	Encoder / Decoder	Description	Signal Type
86	DEC_P3	Decoder	Decoder parity input bit 3. This determines the value of (P) which is the maximum of check bytes that the device will use in correction before flagging the block as uncorrectable. Normally set to the # of check bytes (R). P4 is the most significant bits.	Input
87	ENC_TA0	Encoder	Bit 0 of the encoder T select bus	Input
88	DEC_P2	Decoder	Decoder parity input bit 2. This determines the value of (P) which is the maximum of check bytes that the device will use in correction before flagging the block as uncorrectable. Normally set to the # of check bytes (R). P4 is the most significant bits.	Input
89	Vdd	N/A	+5 Volt Power	Power
90	DEC_P1	Decoder	Decoder parity input bit 1. This determines the value of (P) which is the maximum of check bytes that the device will use in correction before flagging the block as uncorrectable. Normally set to the # of check bytes (R). P4 is the most significant bits.	Input
91	ENC_DIN3	Encoder	Encoder data input bit 3	Input
92	DEC_P4	Decoder	Decoder parity input bit 4. This determines the value of (P) which is the maximum of check bytes that the device will use in correction before flagging the block as uncorrectable. Normally set to the # of check bytes (R). P4 is the most significant bits.	Input
93	ENC_DOUT3	Encoder	Encoder data output bit 3	Tristate
94	ENC_TA3	Encoder	Bit 3 of the encoder T select bus	Input
95	DEC_SHORT2	Decoder	Decoder latency select 2. Selects latency according to Table 2: Latency and Minimum Block Size Selection.	Input
96	NC	N/A	No Connection	
97	ENC_DOUT2	Encoder	Encoder data output bit 2	Tristate
98	NC	N/A	No Connection	
99	ENC_DIN2	Encoder	Encoder data input bit 2	Input
100	NC	N/A	No Connection	
101	Vdd	N/A	+5 Volt Power	Power
102	DEC_RESET	Decoder	Decoder system reset. Assertive LOW. Reset timing is critical to the initialization of the device	Input
103	ENC_DIN1	Encoder	Encoder data input bit 1	Input
104	Vdd	N/A	+5 Volt Power	Power
105	ENC_DOUT1	Encoder	Encoder data output bit 1	Tristate

Table 1: Device Pinout, *continued*

Pin#	Signal Name	Encoder / Decoder	Description	Signal Type
106	GND	N/A	Ground	Power
107	NC	N/A	No Connection	
108	DEC_TEST_SO	Decoder	Foundry Test Pin - Do not Use	
109	GND	N/A	Ground	Power
110	DEC_SHORT1	Decoder	Decoder latency select 1. Selects latency according to Table 2: Latency and Minimum Block Size Selection.	Input
111	ENC_DOUT0	Encoder	Encoder data output bit 0	Tristate
112	GND	N/A	Ground	Power
113	ENC_DIN0	Encoder	Encoder data input bit 0	Input
114	V _{dd}	N/A	+5 Volt Power	Power
115	DEC_TEST_SE	Decoder	Foundry Test Pin - Do not Use	
116	ENC_TEST_SO	Encoder	Foundry Test Pin - Do not Use	
117	DEC_CLOCK	Decoder	Decoder master clock. All inputs and outputs are synchronized by the rising edge of DEC_CLOCK.	Input
118	GND	N/A	Ground	Power
119	DEC_CORR	Decoder	Decoder message block corrected. Assertive HIGH. Indicates that errors have been found and corrected in message block.	Output
120	DEC_EOB	Decoder	Decoder End of Block. 1/0 = End/Not end of block.	Output
121	NC	N/A	No Connection	
122	DEC_DOUT7	Decoder	Data output bit 7. Bit 7 is MSB.	Output
123	DEC_LOC	Decoder	Decoder Error Location. Assertive HIGH. This output goes HIGH if the current symbol outout on Q7-Q0 has had a correction applied to it.	Output
124	V _{dd}	N/A	+5 Volt Power	Power
125	NC	N/A	No Connection	
126	GND	N/A	Ground	Power
127	NC	N/A	No Connection	
128	V _{dd}	N/A	+5 Volt Power	Power

Pinout

Decoder Input Pins

Pin#	Signal	Description	Signal Type
76	DEC_DIN0	Decoder symbol input bit 0. Bit 7 is MSB.	Input
72	DEC_DIN1	Decoder symbol input bit 1. Bit 7 is MSB.	Input
70	DEC_DIN2	Decoder symbol input bit 2. Bit 7 is MSB.	Input
61	DEC_DIN3	Decoder symbol input bit 3. Bit 7 is MSB.	Input
59	DEC_DIN4	Decoder symbol input bit 4. Bit 7 is MSB.	Input
53	DEC_DIN5	Decoder symbol input bit 5. Bit 7 is MSB.	Input
46	DEC_DIN6	Decoder symbol input bit 6. Bit 7 is MSB.	Input
44	DEC_DIN7	Decoder symbol input bit 7. Bit 7 is MSB.	Input

Decoder Output Pins

Pin#	Signal	Description	Signal Type
22	DEC_DOUT0	Data output bit 0. Bit 7 is MSB.	Output
19	DEC_DOUT1	Data output bit 1. Bit 7 is MSB.	Output
18	DEC_DOUT2	Data output bit 2. Bit 7 is MSB.	Output
15	DEC_DOUT3	Data output bit 3. Bit 7 is MSB.	Output
13	DEC_DOUT4	Data output bit 4. Bit 7 is MSB.	Output
9	DEC_DOUT5	Data output bit 5. Bit 7 is MSB.	Output
7	DEC_DOUT6	Data output bit 6. Bit 7 is MSB.	Output
122	DEC_DOUT7	Data output bit 7. Bit 7 is MSB.	Output

Decoder Error Magnitude Pins

Pin#	Signal	Description	Signal Type
2	DEC_MAG0	Error Magnitude 0. This output indicates which bit of the current symbol output on Q7-Q0 has been corrected when LOC is HIGH. This output is indeterminate and should be ignored when LOC is low.	Output
4	DEC_MAG1	Error Magnitude 1. This output indicates which bit of the current symbol output on Q7-Q0 has been corrected when LOC is HIGH. This output is indeterminate and should be ignored when LOC is low.	Output

Decoder Error Magnitude Pins, *continued*

Pin#	Signal	Description	Signal Type
6	DEC_MAG2	Error Magnitude 2. This output indicates which bit of the current symbol output on Q7-Q0 has been corrected when LOC is HIGH. This output is indeterminate and should be ignored when LOC is low.	Output
25	DEC_MAG3	Error Magnitude 3. This output indicates which bit of the current symbol output on Q7-Q0 has been corrected when LOC is HIGH. This output is indeterminate and should be ignored when LOC is low.	Output
27	DEC_MAG4	Error Magnitude 4. This output indicates which bit of the current symbol output on Q7-Q0 has been corrected when LOC is HIGH. This output is indeterminate and should be ignored when LOC is low.	Output
30	DEC_MAG5	Error Magnitude 5. This output indicates which bit of the current symbol output on Q7-Q0 has been corrected when LOC is HIGH. This output is indeterminate and should be ignored when LOC is low.	Output
39	DEC_MAG6	Error Magnitude 6. This output indicates which bit of the current symbol output on Q7-Q0 has been corrected when LOC is HIGH. This output is indeterminate and should be ignored when LOC is low.	Output
42	DEC_MAG7	Error Magnitude 7. This output indicates which bit of the current symbol output on Q7-Q0 has been corrected when LOC is HIGH. This output is indeterminate and should be ignored when LOC is low.	Output

Decoder Parity Input Pins

Pin#	Signal	Description	Signal Type
90	DEC_P1	Decoder parity input bit 1. This determines the value of (P) which is the maximum of check bytes that the device will use in correction before flagging the block as uncorrectable. Normally set to the # of check bytes (R). P4 is the most significant bits.	Input
88	DEC_P2	Decoder parity input bit 2. This determines the value of (P) which is the maximum of check bytes that the device will use in correction before flagging the block as uncorrectable. Normally set to the # of check bytes (R). P4 is the most significant bits.	Input
86	DEC_P3	Decoder parity input bit 3. This determines the value of (P) which is the maximum of check bytes that the device will use in correction before flagging the block as uncorrectable. Normally set to the # of check bytes (R). P4 is the most significant bits.	Input
92	DEC_P4	Decoder parity input bit 4. This determines the value of (P) which is the maximum of check bytes that the device will use in correction before flagging the block as uncorrectable. Normally set to the # of check bytes (R). P4 is the most significant bits.	Input

Decoder Latency Select Pins

Pin#	Signal	Description	Signal Type
110	DEC_SHORT1	Decoder latency select 1. Selects latency according to Table 2: Latency and Minimum Block Size Selection.	Input
95	DEC_SHORT2	Decoder latency select 2. Selects latency according to Table 2: Latency and Minimum Block Size Selection.	Input

Decoder Control and Status Pins

Pin#	Signal	Description	Signal Type
117	DEC_CLOCK	Decoder master clock. All inputs and outputs are synchronized by the rising edge of DEC_CLOCK.	Input
119	DEC_CORR	Decoder message block corrected. Assertive HIGH. Indicates that errors have been found and corrected in message block.	Output
24	DEC_DATARDY	Data Ready. Assertive HIGH. This output is held HIGH for data bytes and low check bytes.	Output
80	DEC_DATEN	Decoder data enable. Assertive HIGH. This input is used to signal the difference between data bytes and check bytes.	Input
81	DEC_ENABIN	Decoder enable data correction. Assertive HIGH. When this input is asserted, the device performs corrections on the message block. When CEN is low, the device does not perform corrections but continues to report status is initialized to do so.	Input
120	DEC_EOB	Decoder End of Block. 1/0 = End/Not end of block.	Output
123	DEC_LOC	Decoder Error Location. Assertive HIGH. This output goes HIGH if the current symbol output on Q7-Q0 has had a correction applied to it.	Output
102	DEC_RESET	Decoder system reset. Assertive LOW. Reset timing is critical to the initialization of the device.	Input
40	DEC_STATEN	Status Enable. Assertive HIGH. If this signal is HIGH during reset then the decoder will be programmed to output two status bytes with each message block.	Input
65	DEC_UNCORR	Decoder uncorrectable block. Assertive HIGH. Indicates message block contains uncorrectable errors.	Output

Encoder Data Input Pins

Pin#	Signal	Description	Signal Type
113	ENC_DIN0	Encoder data input bit 0.	Input
103	ENC_DIN1	Encoder data input bit 1.	Input
99	ENC_DIN2	Encoder data input bit 2.	Input
91	ENC_DIN3	Encoder data input bit 3.	Input
63	ENC_DIN4	Encoder data input bit 4.	Input
67	ENC_DIN5	Encoder data input bit 5.	Input
50	ENC_DIN6	Encoder data input bit 6.	Input
54	ENC_DIN7	Encoder data input bit 7.	Input

Encoder Data Output Pins

Pin#	Signal	Description	Signal Type
111	ENC_DOUT0	Encoder data output bit 0	Tristate
105	ENC_DOUT1	Encoder data output bit 1	Tristate
97	ENC_DOUT2	Encoder data output bit 2	Tristate
93	ENC_DOUT3	Encoder data output bit 3	Tristate
60	ENC_DOUT4	Encoder data output bit 4	Tristate
68	ENC_DOUT5	Encoder data output bit 5	Tristate
48	ENC_DOUT6	Encoder data output bit 6	Tristate
56	ENC_DOUT7	Encoder data output bit 7	Tristate

Encoder T Select Pins

Pin#	Signal	Description	Signal Type
87	ENC_TA0	Bit 0 of the encoder T select bus	Input
85	ENC_TA1	Bit 1 of the encoder T select bus	Input
83	ENC_TA2	Bit 2 of the encoder T select bus	Input
94	ENC_TA3	Bit 3 of the encoder T select bus	Input

Encoder Control and Status Pins

Pin#	Signal	Description	Signal Type
79	ENC_TRIEN	Tri-states the encoder ENC_DOUT bus drivers when HIGH	Input
75	ENC_ENIN	Enable encoder DIN bus into the parity generator	Input
73	ENC_ENOUT	Enables encoder DIN bus onto the DOUT bus	Input
71	ENC_RDY	Indicates data symbols are on the encoder ENC_DOUT bus	Output
77	ENC_RESET	Initializes encoder into a know state (high)	Input
82	ENC_CLOCK	Encoder master and symbol clock.	Input

Encoder and Decoder Foundry Test Pins

Pin#	Signal	Description	Signal Type
115	DEC_TEST_SE	Foundry Test Pin - Do not Use	Input
51	DEC_TEST_SI	Foundry Test Pin - Do not Use	Input
108	DEC_TEST_SO	Foundry Test Pin - Do not Use	Output
36	ENC_TEST_SE	Foundry Test Pin - Do not Use	Input
45	ENC_TEST_SI	Foundry Test Pin - Do not Use	Input
116	ENC_TEST_SO	Foundry Test Pin - Do not Use	Output

Ground Pins

Pin#	Signal	Description
11	GND	Ground
20	GND	Ground
23	GND	Ground
37	GND	Ground
38	GND	Ground
47	GND	Ground
55	GND	Ground
58	GND	Ground
69	GND	Ground
78	GND	Ground
106	GND	Ground
109	GND	Ground
112	GND	Ground
118	GND	Ground
126	GND	Ground

No Connect Pins

Pin#	Signal	Description
1	NC	No Connection
3	NC	No Connection
5	NC	No Connection
10	NC	No Connection
12	NC	No Connection
14	NC	No Connection
16	NC	No Connection
21	NC	No Connection
26	NC	No Connection
28	NC	No Connection
29	NC	No Connection
31	NC	No Connection
32	NC	No Connection
33	NC	No Connection
34	NC	No Connection

No Connect Pins, continued

Pin#	Signal	Description
41	NC	No Connection
62	NC	No Connection
64	NC	No Connection
96	NC	No Connection
98	NC	No Connection
100	NC	No Connection
107	NC	No Connection
121	NC	No Connection
125	NC	No Connection
127	NC	No Connection

Voltage Supply Pins

Pin#	Signal	Description
8	V _{dd}	+5 V Power
17	V _{dd}	+5 V Power
35	V _{dd}	+5 V Power
43	V _{dd}	+5 V Power
49	V _{dd}	+5 V Power
52	V _{dd}	+5 V Power
57	V _{dd}	+5 V Power
66	V _{dd}	+5 V Power
74	V _{dd}	+5 V Power
84	V _{dd}	+5 V Power
89	V _{dd}	+5 V Power
101	V _{dd}	+5 V Power
104	V _{dd}	+5 V Power
114	V _{dd}	+5 V Power
124	V _{dd}	+5 V Power
128	V _{dd}	+5 V Power

Packaging

Table 6: PLCC Dimensions

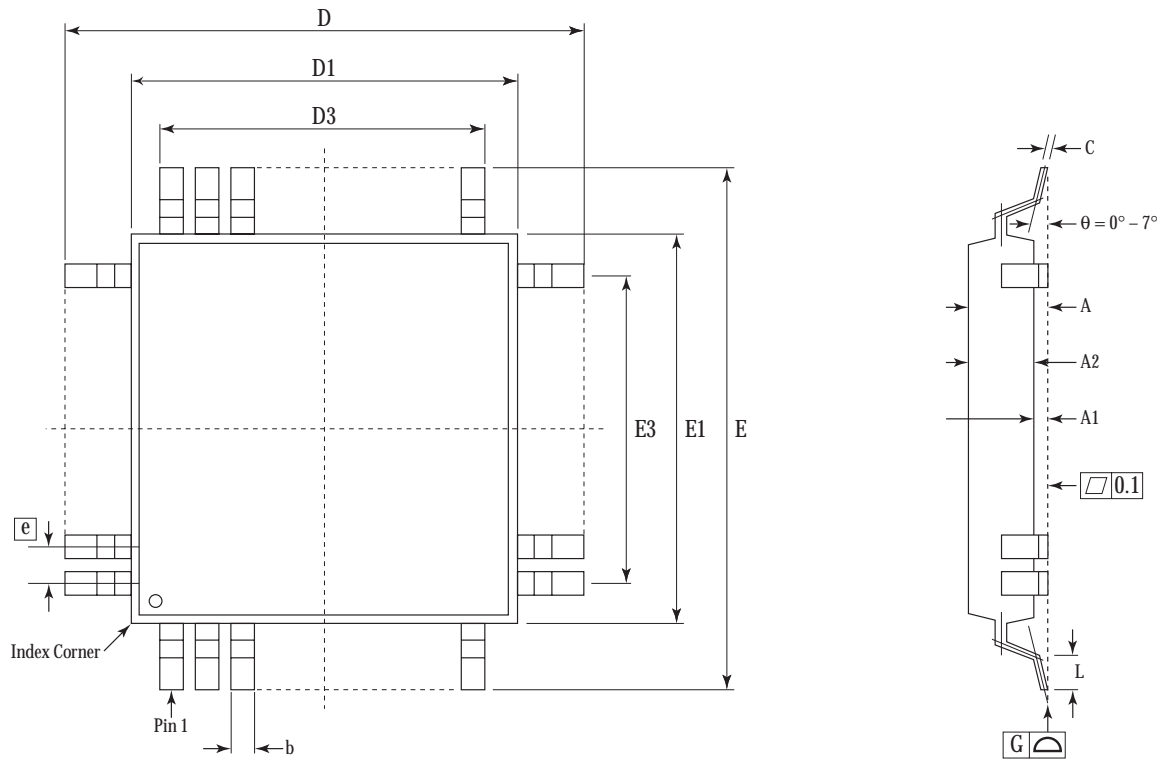

Notes:

1. Pin 1 indicator may be a corner chamfer, dot or both.
2. Controlling dimensions are in millimeters.
3. The top package body size may be smaller than the bottom package body size by a max. of 0.15 mm.
4. Dimension D1 and E1 do not include mold protrusion. Allowable protrusion is 0.25mm per side. D1 and E1 are maximum plastic body size dimensions including mold mismatch.
5. Dimension b does not include dambar protrusion. Allowable dambar protrusion shall not cause the lead width to exceed the maximum b dimension by more than 0.08 mm.
6. Coplanarity, measured at seating plane G, to be 0.10 mm max.

Part Numbers: Complete ordering code COic5130A

Parts are packaged in anti static tubes of 18 units each.

To order call 650-321-3390, fax 650-322-8569, or email sales@co-optic.com

Symbol	Control Dimensions in millimeters			Alternate Dimensions in inches		
	Min	Nominal	Max	Min	Nominal	Max
A	3.45		4.10	0.136		0.161
A1	0.25		0.50	0.010		0.020
A2	3.20		3.60	0.126		0.142
D	30.95		31.45	1.219		1.238
D1	27.80		28.20	1.094		1.110
D3	24.80 Ref.			0.976 Ref.		
E	30.95		31.45	1.219		1.238
E1	27.80		28.20	1.094		1.110
E3	24.80 Ref.			0.976 Ref.		
L	0.73		1.03	0.029		0.041
e	0.80 BSC.			0.031 BSC.		
b	0.30		0.45	0.012		0.018
c	0.11		0.23	0.004		0.009
	Pin Features					
N	128					
ND	32					
NE	32					
Note	Square					