



**LIGITEK ELECTRONICS CO.,LTD.**  
**Property of Ligitek Only**

---

**LED SMD**



Lead-Free Parts

**LG-020WK-DT-N12**

**DATA SHEET**

DOC. NO : QW0905-LG-020WK-DT-N12

REV. : A

DATE : 20 - Jun - 2006



**Features:**

- 1. Side view white LED.
- 2. white SMT package.
- 3. Leadframe package with individual 2 pin.
- 4. Wide viewing angle.
- 5. Soldering methods: IR reflow soldering.
- 6. Feature of the device: more light due to higher optical efficiency; extremely wide viewing angle; ideal for backlighting and coupling in light guide.
- 7. ESD protection.
- 8. Pb free

**Descriptions:**

The LG-020 SMD has wide viewing angle, low power consumption and white LEDs are devices which are materialized by combining blue LEDs and special phosphors. This feature makes the LED ideal for light guide application.

**Applications:**

- 1. LCD back light.
- 2. Mobile phones.
- 3. Indicators.
- 4. Switch lights.

**Device Selection Guide:**

PART NO	MATERIAL	COLOR	
		Emitted	Lens
LG-020WK-DT-N12	InGaN/GaN	White	Yellow Diffused



### Package Dimensions

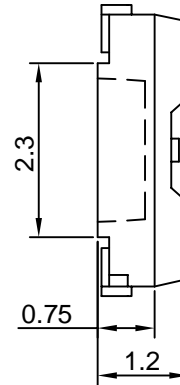
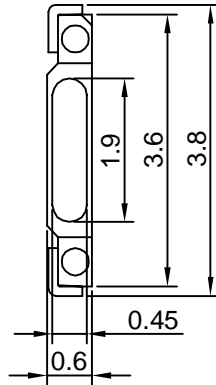
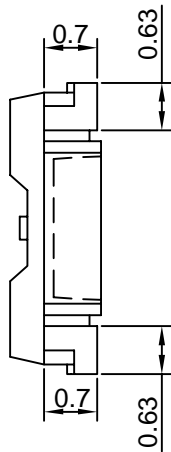

Cathode

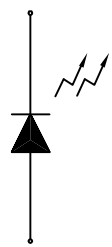

Anode

Polarity

Note : 1.All dimension are in millimeter tolerance is  $\pm 0.1\text{mm}$  unless otherwise noted.  
2.Specifications are subject to change without notice.

### Recommended Soldering Pad Dimensions

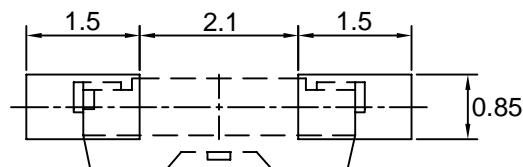

Note : The tolerances unless mentioned is  $\pm 0.1\text{mm}$ , Angle  $\pm 0.5$ . Unit=mm.

**Absolute Maximum Ratings at Ta=25**

Parameter	Symbol	Ratings	UNIT
Power Dissipation	PD	80	mW
Peak Forward Current Duty 1/10@10KHz	IFP	100	mA
Forward Current	IF	20	mA
Reverse Current @5V	Ir	50	μ A
Electrostatic Discharge	ESD	± 2000	V
Operating Temperature	Topr	-40 ~ +85	
Storage Temperature	Tstg	-40 ~ +90	
Soldering Temperature	Tsol	Max 260 for 5 sec Max	

**Typical Electrical & Optical Characteristics (Ta=25 )**

Items	Symbol	Min.	Typ.	Max.	Unit	Condition
Chromaticity Coordinates	CIE_x	----	0.3	----	----	IF=20mA
	CIE_y	----	0.29	----	----	
Luminous Intensity	Iv	960	1200	----	mcd	IF=20mA
Forward Voltage	V <sub>F</sub>	----	3.3	----	V	IF=20mA
Viewing Angle	2 1/2	----	110	----	deg	IF=20mA

Note : 1.The forward voltage data did not including ±0.1V testing tolerance.  
 2. The luminous intensity data did not including ±10% testing tolerance.

**Luminous Intensity Classification (at 20mA)**

Group	BIN CODE	Iv(mvd)	
		Min.	Max.
V-2	V-21	950	1000
	V-22	1000	1050
	V-23	1050	1100
	V-24	1100	1150
W-1	W-11	1150	1200
	W-12	1200	1250
	W-13	1250	1300
	W-14	1300	1350
	W-15	1350	1400
W-2	W-21	1400	1450
	W-22	1450	1500
	W-23	1500	1550
	W-24	1550	1600
	W-25	1600	1650

**Forward Voltage Classification (at 20mA)**

BIN CODE	Vf(v)	
	Min.	Max.
1	2.8	3.0
2	3.0	3.2
3	3.2	3.4
4	3.4	3.6



### Chromaticity Coordinates Specifications For Bin Grading

CIE BLOCK			Coordinate				
			LEFT	BOTTOM	RIGHT	TOP	
N1	A31	x	0.264	0.272	0.282	0.276	
		y	0.267	0.258	0.272	0.281	
	A33	x	0.276	0.282	0.292	0.287	
		y	0.281	0.272	0.286	0.295	
	B51	x	0.287	0.292	0.3	0.297	
		y	0.295	0.286	0.295	0.305	
	B53	x	0.297	0.3	0.309	0.307	
		y	0.305	0.295	0.305	0.315	
	B61	x	0.307	0.309	0.319	0.319	
		y	0.315	0.305	0.316	0.327	
	B63	x	0.319	0.319	0.33	0.33	
		y	0.327	0.316	0.329	0.339	
	N1	A32	x	0.272	0.28	0.288	0.282
			y	0.258	0.248	0.262	0.272
A34		x	0.282	0.288	0.296	0.292	
		y	0.272	0.262	0.276	0.286	
B52		x	0.292	0.296	0.304	0.3	
		y	0.286	0.276	0.285	0.295	
B54		x	0.3	0.304	0.311	0.309	
		y	0.295	0.285	0.294	0.305	
B62		x	0.309	0.311	0.32	0.319	
		y	0.305	0.294	0.305	0.316	
B64		x	0.319	0.32	0.33	0.33	
		y	0.316	0.305	0.318	0.329	

CIE BLOCK			Coordinate				
			LEFT	BOTTOM	RIGHT	TOP	
N2	B72	x	0.288	0.291	0.3	0.296	
		y	0.262	0.257	0.268	0.276	
	B74	x	0.296	0.3	0.306	0.304	
		y	0.276	0.268	0.277	0.285	
	B82	x	0.304	0.306	0.313	0.311	
		y	0.285	0.277	0.285	0.294	
	B84	x	0.311	0.313	0.321	0.32	
		y	0.294	0.285	0.294	0.305	
	N2	A41	x	0.28	0.287	0.295	0.288
			y	0.248	0.24	0.251	0.262
		B71	x	0.291	0.295	0.303	0.3
			y	0.257	0.251	0.261	0.268
B73		x	0.3	0.303	0.309	0.306	
		y	0.268	0.261	0.268	0.277	
B81		x	0.306	0.309	0.315	0.313	
		y	0.277	0.268	0.276	0.285	
B83		x	0.313	0.315	0.322	0.321	
		y	0.285	0.276	0.285	0.294	



CIE Chromaticity Diagram

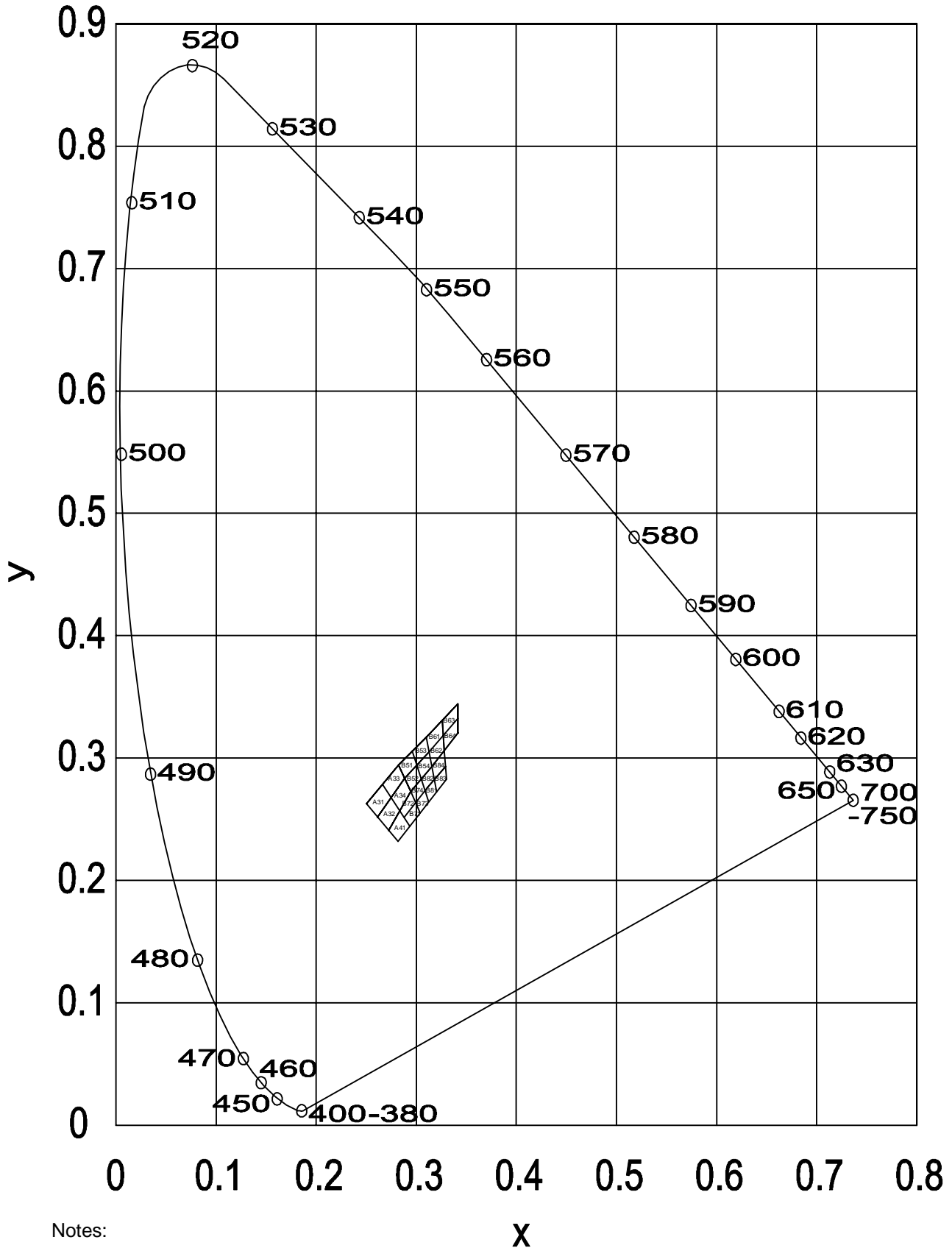

Notes:

1. Tolerance of CIE Chromaticity coordinate(x,y)  $\pm 0.003$ .



### Typical Electro-Optical Characteristics Curve

WK CHIP

Fig.1 Forward current vs. Forward Voltage

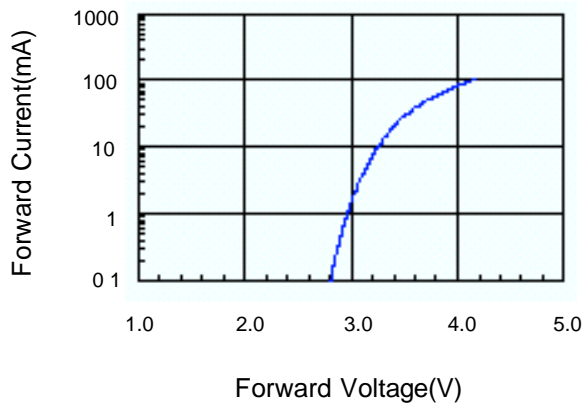

Fig.2 Relative Intensity vs. Forward Current

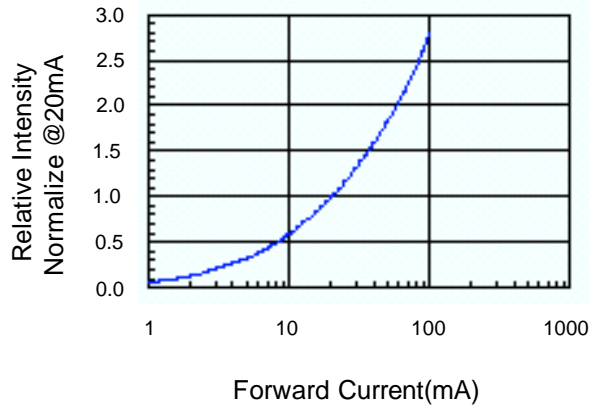

Fig.3 Forward Voltage vs. Temperature

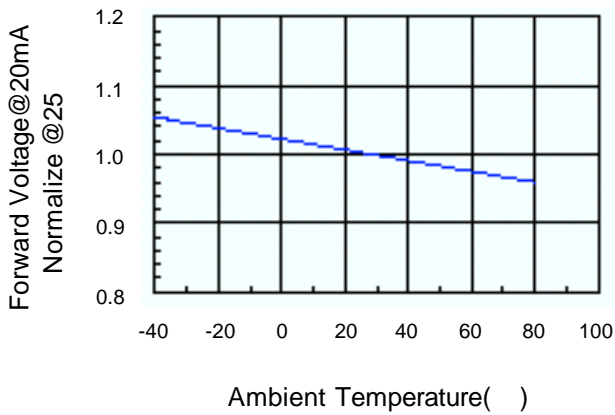

Fig.4 Relative Intensity vs. Temperature

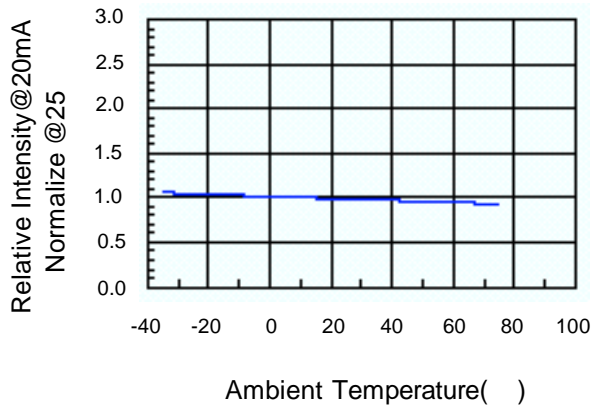
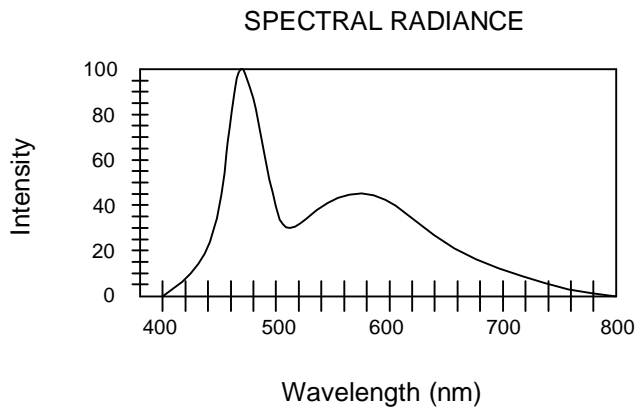

Fig.5 Luminous Spectrum (Ta=25 °C)







LIGITEK

LIGITEK ELECTRONICS CO.,LTD.  
Property of Ligitek Only

PART NO. LG-020WK-DT-N12

Page 8/13

### Carrier Type Dimensions

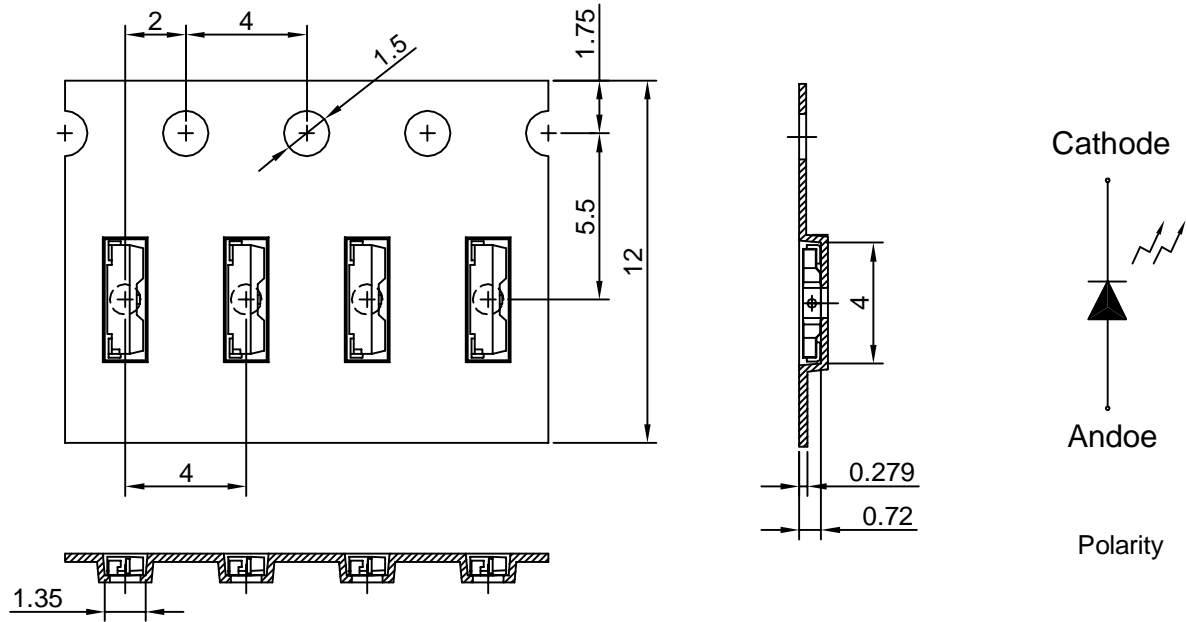

Note : The tolerances unless mentioned is  $\pm 0.1\text{mm}$ , Angle  $\pm 0.5$ . Unit=mm.

### Packing Specifications

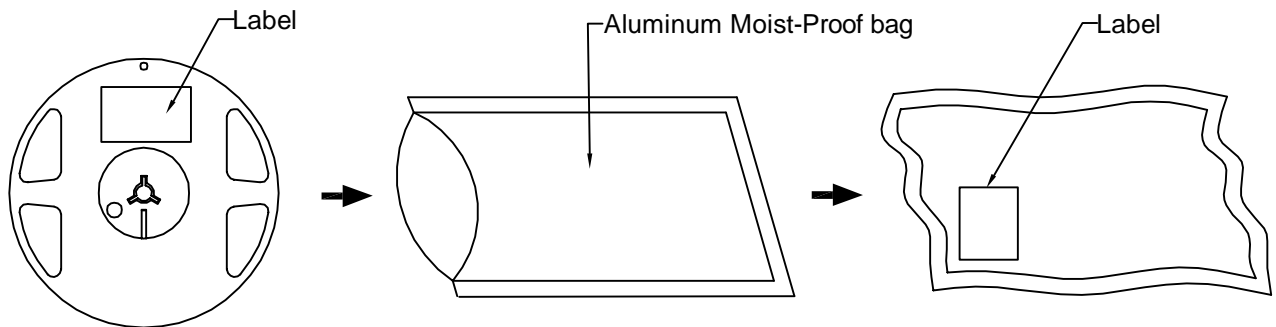

Part No.	Description	Quantity/Reel
LG-020WK-DT-N12	12mm tape, 7" reel	5000 devices





LIGITEK

LIGITEK ELECTRONICS CO.,LTD.  
Property of Ligitek Only

PART NO. LG-020WK-DT-N12

Page 9/13

### Label Explanation

 立碁電子工業股份有限公司 LIGITEK ELECTRONICS CO., LTD.		
PART NO. : LG-020WK-DT-N12		
LOT NO. : MC9500498		
Q'TY(PCS) : 5000 PCS		Vf:3.0 - 3.2
BIN/HUE : W11/ B52		

BIN : Luminous Intensity

HUE : Chromaticity Coordinates  
(CIE\_x , CIE\_y)

3.0 - 3.2 : Forward Voltage

### Reel Dimensions

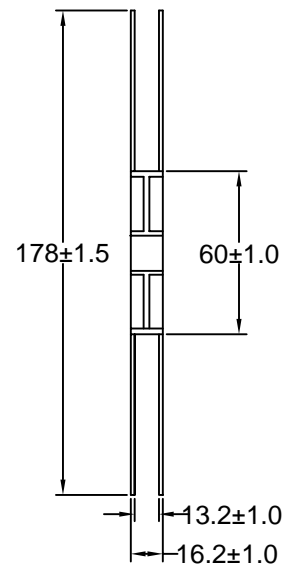
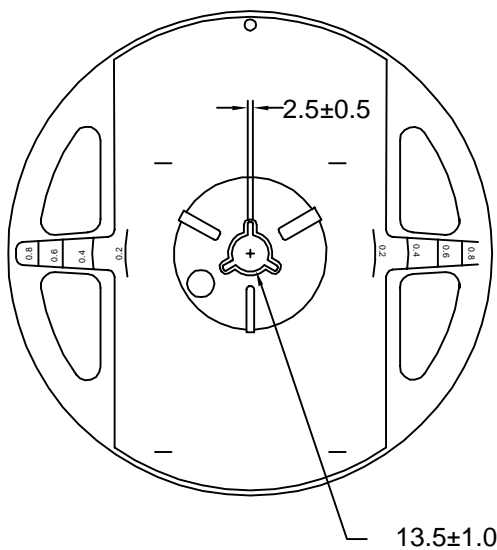



### Box Explanation

- 1. 5 BAG / INNER BOX
- 2. INNER BOX SIZE : L X W X H 23cm X 8.5cm x 26cm

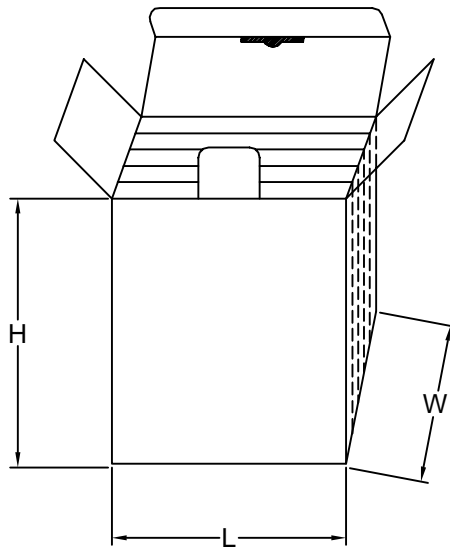

- 3. 10 INNER BOXES / CARTON
- 4. CARTON SIZE : L X W X H 49cm X 46cm x 29cm

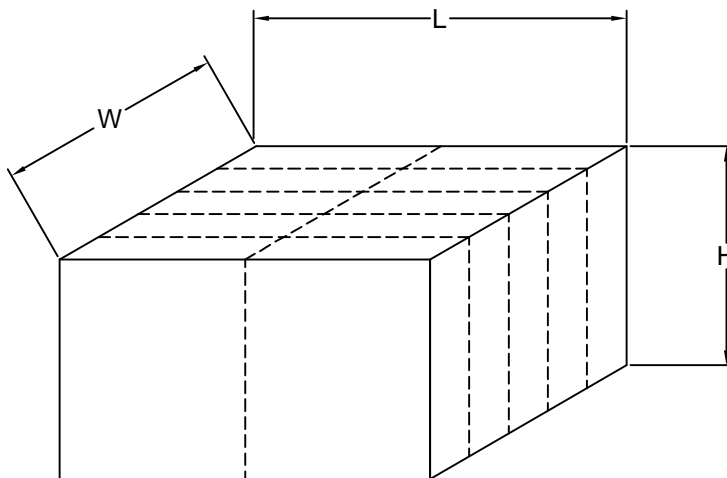



Soldering Iron:

Basic spec is 5 seconds when 260 .  
Power dissipation of iron should be smaller than 25W,and temperature should be controllable.  
Surface temperature of the device should be under 280 for 3 seconds.

Reflow Temp/Time(Pb-free)

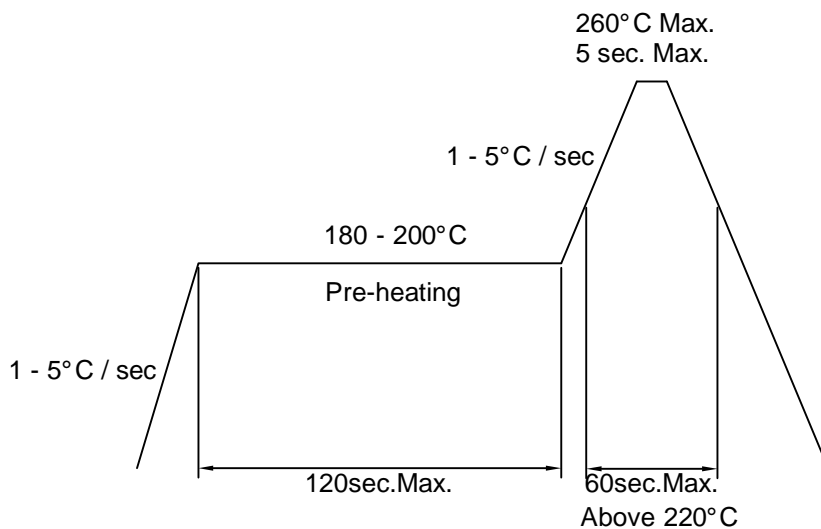

Reflow Temp/Time(Lead solder)

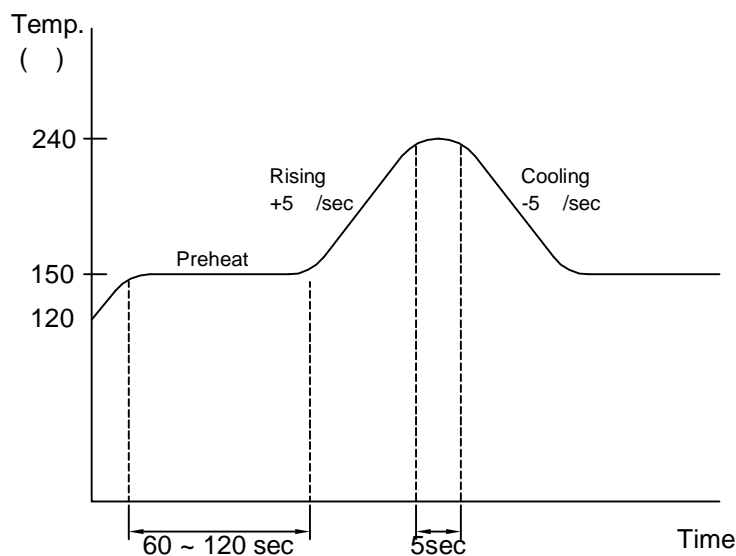

Note:

- 1.Reflow soldering should not be done more than two times.
- 2.When soldering,do not put stress on the LEDs during heating.
- 3.After soldering,do not warp the circuit board.

**Precautions For Use:**
**Storage time:**

- 1.The operation of Temperatures and RH are : 5 ~35 ,RH60%.
- 2.Once the package is opened, the products should be used within a week.  
Otherwise, they should be kept in a damp proof box with desiccating agent.  
Considering the tape life, we suggest our customers to use our products within a year(from production date).
- 3.If opened more than one week in an atmosphere 5 ~ 35 ,RH60%,  
they should be treated at 60 ±5 fo r 15hrs.

**Drive Method:**

LED is a current operated device, and therefore, requires some kind of current limiting incorporated into the driver circuit. This current limiting typically takes the form of a current limiting resistor placed in series with the LED.

Consider worst case voltage variations that could occur across the current limiting resistor. The forward current should not be allowed to change by more than 40 % of its desired value.

Circuit model A

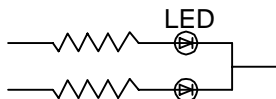

Circuit model B

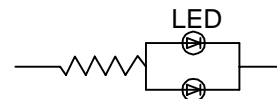

(A) Recommended circuit.

(B) The difference of brightness between LED could be found due to the VF-IF characteristics of LED.

**Cleaning:**

Use alcohol-based cleaning solvents such as isopropyl alcohol to clean the LED.

**ESD(Electrostatic Discharge):**

Static Electricity or power surge will damage the LED. Use of a conductive wrist band or anti-electrostatic glove is recommended when handling these LED. All devices, equipment and machinery must be properly grounded.



**Reliability Test:**

(1)Test items and results

Classification	Test Item	Test Condition	Sample Size
Endurance Test	Operating Life Test	1.Ta=Under Room Temperature As Per Data Sheet Maximum Rating. 2.If=20mA 3.t=1000 hrs	22
	High Temperature Storage Test	1.Ta=105 ±5 2.t=500 hrs	22
	Low Temperature Storage Test	1.Ta=-40 ±5 2.t=1000 hrs	22
	High Temperature High Humidity Storage Test	1.IR-Reflow In-Board, 2 Times 2.Ta=85 ±5 3.RH=90 %~95% 4.t=500hrs±2hrs	22
Environmental Test	Thermal Shock Test	1.IR-Reflow In-Board,2 times 2.Ta=105 ±5 & -40 ±5 (30min) (30min) 3.total 100 cycles	22
	Reflow Soldering Test	1.T.Sol=260 ±5 2.Dwell Time= 10 Max.	22
	Temperature Cycling	1.105 ~ 25 ~ -40 30mins 15mins 30mins 2.100 Cyeles	22

(2)Criteria for judging the damage

Item	Symbol	Test Conditions	Criteria for Judgement	
			Min.	Max.
Forward Voltage	Vf	If=20mA	-	U.S.L x1.2
Reverse Current	Ir	Vr=5V	-	U.S.L x2.0
Luminous Intensity	Iv	If=20mA	L.S.L x 0.5	-

Note:

1.U.S.L.:Upper Standard Level.

2.L.S.L.:Lower Standard Level.