

PROTECTION PRODUCTS

Description

The STF201 is a combination EMI filter and line termination device with integrated TVS diodes for use on downstream USB ports. It is constructed using a proprietary technology that allows passive components and TVS diodes to be integrated in the same package. Each device will provide **termination, filtering, and ESD protection** for one downstream USB port. The STF201 is an easily implemented solution for meeting the requirements of revision 1.1 of the Universal Serial Bus specification.

USB line termination is achieved with series 22Ω or 30Ω resistors on both the D+ and D- USB lines. These resistors preserve signal integrity by matching the cable impedance to that of the differential driver. The $15k\Omega$ pull-down resistors complete the termination circuit on each line. They are required by the USB specification to identify the line as a downstream connection. The $47pF$ capacitors are used to bypass high frequency energy to ground and for edge rate control of the USB signals. Finally, the STF201 contains TVS diodes for ESD protection of both (D+ & D-) data lines and the voltage bus (V_{BUS}). The TVS diodes provide effective suppression of ESD voltages in excess of $15kV$ (air discharge) and $8kV$ (contact discharge) per IEC 61000-4-2, level 4.

The small size and integrated feature of the STF201 minimizes required board space and increases system reliability. The pin-out of the device allows easy implementation. The STF201 is suitable for use in USB hubs, computers, peripherals, and portable devices.

Features

- ◆ Bidirectional EMI/RFI filtering and line termination with integrated ESD protection
- ◆ ESD protection for USB power (V_{BUS}) and data lines (D+ & D-) to **IEC 61000-4-2 Level 4**
- ◆ Filtering and termination for two USB data lines
- ◆ Different series resistors for impedance matching
- ◆ Low TVS operating voltage (5.25V)
- ◆ Low leakage current
- ◆ Low capacitance
- ◆ Solid-state technology

Mechanical Characteristics

- ◆ EIAJ SOT23-6L package
- ◆ Molding compound flammability rating: UL 94V-0
- ◆ Marking : Marking Code
- ◆ Packaging : Tape and Reel per EIA 481

Applications

- ◆ USB Hubs
- ◆ Portable electronics
- ◆ Printers
- ◆ Monitors
- ◆ Servers, Desktop, and Notebook computers

Circuit Diagram

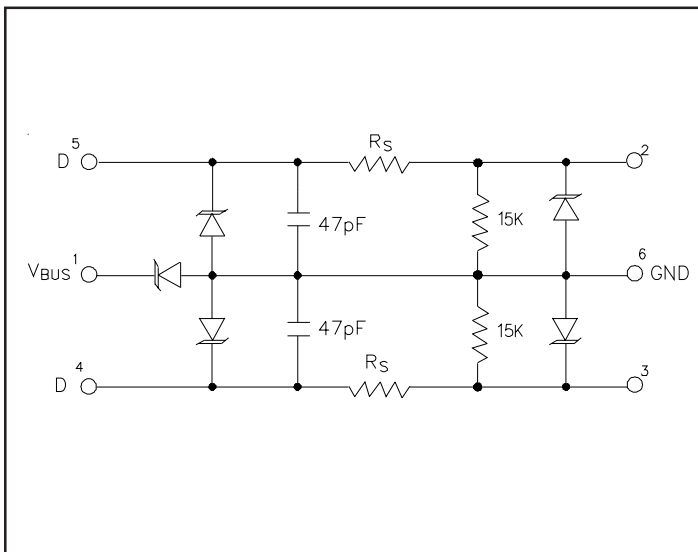

Pin Configuration

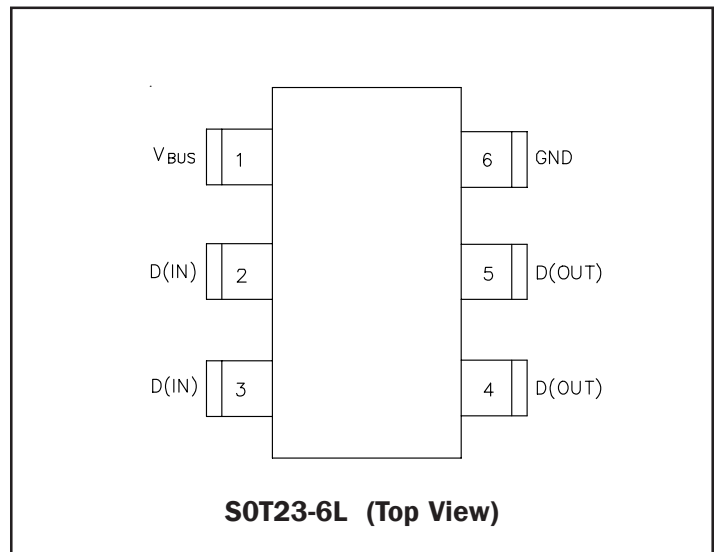

PROTECTION PRODUCTS
Absolute Maximum Rating

Rating	Symbol	Value	Units
Steady-State Power	P_{pk}	100	mW
ESD Air Discharge per IEC 61000-4-2 ESD Contact Discharge per IEC 61000-4-2	V_{ESD}	15 8	kV
Lead Soldering Temperature	T_L	260 (10 sec.)	°C
Operating Temperature	T_J	-40 to +125	°C
Storage Temperature	T_{STG}	-55 to +150	°C

Electrical Characteristics

STF201-xx						
Parameter	Symbol	Conditions	Minimum	Typical	Maximum	Units
TVS Reverse Stand-Off Voltage	V_{RWM}				5.25	V
TVS Reverse Breakdown Voltage	V_{BR}	$I_t = 1mA$	6			V
TVS Reverse Leakage Current	I_R	$V_{RWM} = 5.25V, T=25^\circ C$ Between V_{BUS} pin and Ground			5	μA
TVS Reverse Leakage Current	I_R	$V_{RWM} = 3.3V, T=25^\circ C$ Between any data (D+, D-) pin and Ground.			1	μA
TVS Junction Capacitance	C_j	Between I/O pins and Ground, each device $V_R = 0V, f = 1MHz$		10		pF
Series Resistance (STF201-22)	R_s	Each Line	20	22	24	Ω
Series Resistance (STF201-30)	R_s	Each Line	27	30	33	Ω
Pulldown Resistance	R_{PD}	Each Line	13.5	15	16.5	k Ω
Capacitor	C	Each Line		47		pF
Total Capacitance	C_{TOT}	Between Input or Output to Ground $V_R = 0V, f = 1MHz$		60		pF

PROTECTION PRODUCTS

Typical Characteristics

ESD Clamping (8kV Contact)

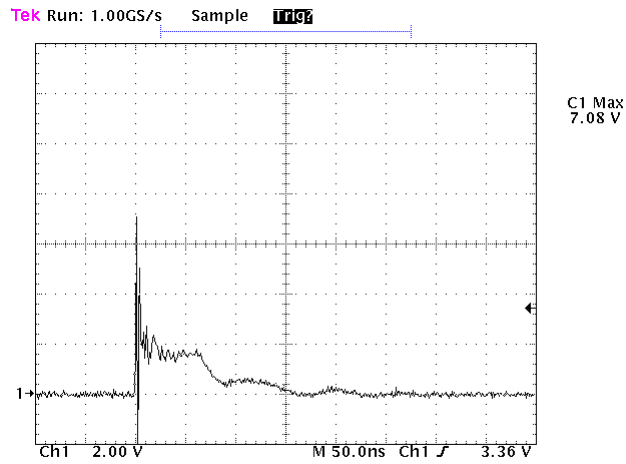

ESD Clamping (15kV Air)

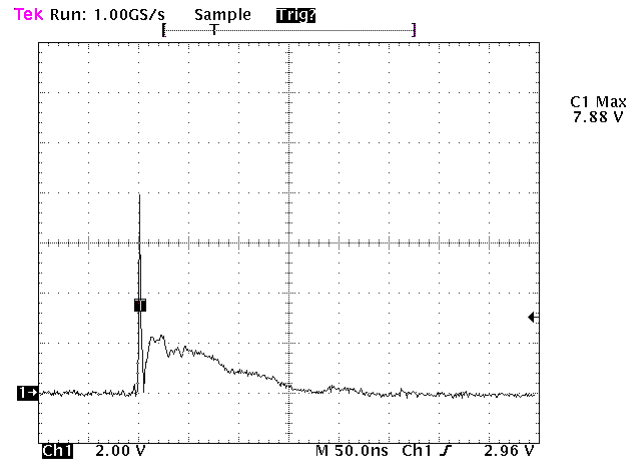

Typical Insertion Loss

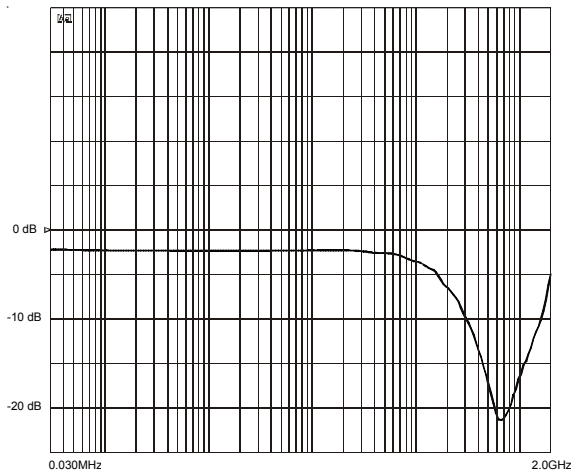

Analog Crosstalk (D+ to D-)

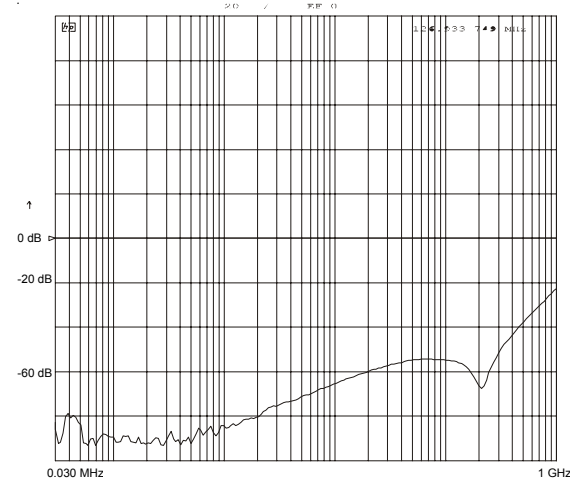

PROTECTION PRODUCTS

Applications Information

Device Connection

The STF201 is designed to provide termination, EMI filtering and ESD protection for two USB I/O lines. The equivalent circuit diagram is shown in Figure 1. The device is connected as follows:

- USB data lines are routed through the STF201 for easy implementation and optimum pc board layout. Pin 1 is connected to the voltage supply line. The input of the D+ line is routed into pin 2 and out of pin 5. The input of the D- line is connected at pin 3 and the output at pin 4. Pin 6 is connected to ground. The ground connection should be made directly to the ground plane for best results. The path length is kept as short as possible to reduce the effects of parasitic inductance in the board traces.

USB Port Design Considerations

The Universal Serial Bus (USB) specification requires termination and filtering components for proper operation. In addition, an open USB socket is vulnerable to hazardous ESD discharges in excess of 15kV. These discharges can occur on the data lines or the voltage bus. The STF201 is an easily implemented solution designed to meet the termination & EMI filter requirements of the USB specification revision 1.1. It also provides ESD protection to IEC 61000-4-2, level 4.

A simplified USB port is shown in Figure 3. USB line termination is achieved with series resistors on both the D+ and D- lines. These resistors preserve signal integrity by matching the cable impedance to that of the differential driver. 15kΩ pull-down resistors are used to identify a downstream port while an upstream port is identified with a 1.5KΩ pull up resistor on either the D+ (full speed devices) or the D- (low speed devices) data line. Capacitors are used to bypass high frequency energy to ground and for edge rate control of the USB signals. TVS diodes are added for ESD protection of both (D+ & D-) data lines and the voltage bus (V_{BUS}). A power distribution switch and voltage regulator provide the power management functions of the port.

Semtech provides a complete solution to simplify USB port design (Figure 4). The STF201 & STF202 integrate all of the components necessary for line termina-

Figure 1 - STF201 Functional Circuit Diagram

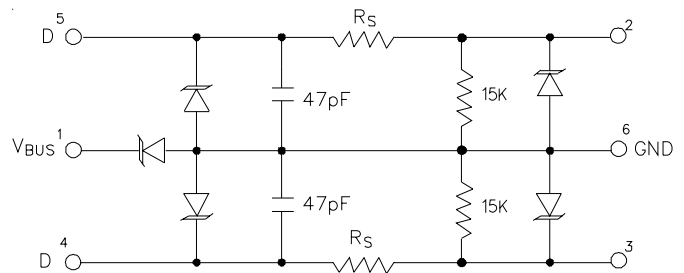
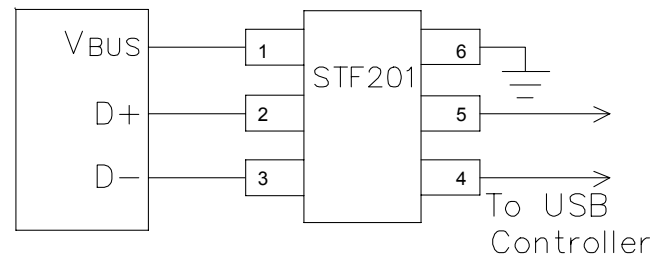

Figure 2 - STF201 Connection Diagram



tion, bidirectional EMI filtering, and ESD protection on downstream (STF201) or upstream (STF202) ports. The SC5826 is a dual port power switch that provides individual or ganged port switching, fault reporting, and inrush current limiting as required by the USB specification. The SC5205 ULDO provides a stable voltage to the USB controller.

Board Placement & layout Guidelines.

Board layout and placement of the STF201 play a critical role in EMI & ESD suppression. Designing a USB hub to meet EMI & ESD immunity requirements requires a combination of optimum component placement, trace routing, and good circuit design practices. Some general guidelines are given below:

- Avoid running D+ & D- signal line traces near high speed clock lines or similar signal lines.
- Avoid running critical signal lines near board edges.
- Locate the USB controller chip physically near the USB connectors.
- Place the STF201 near the USB connector to restrict transient coupling.
- Minimize the path length between the USB connector and the STF201 as well as between the USB controller and the STF201.

PROTECTION PRODUCTS

Applications Information

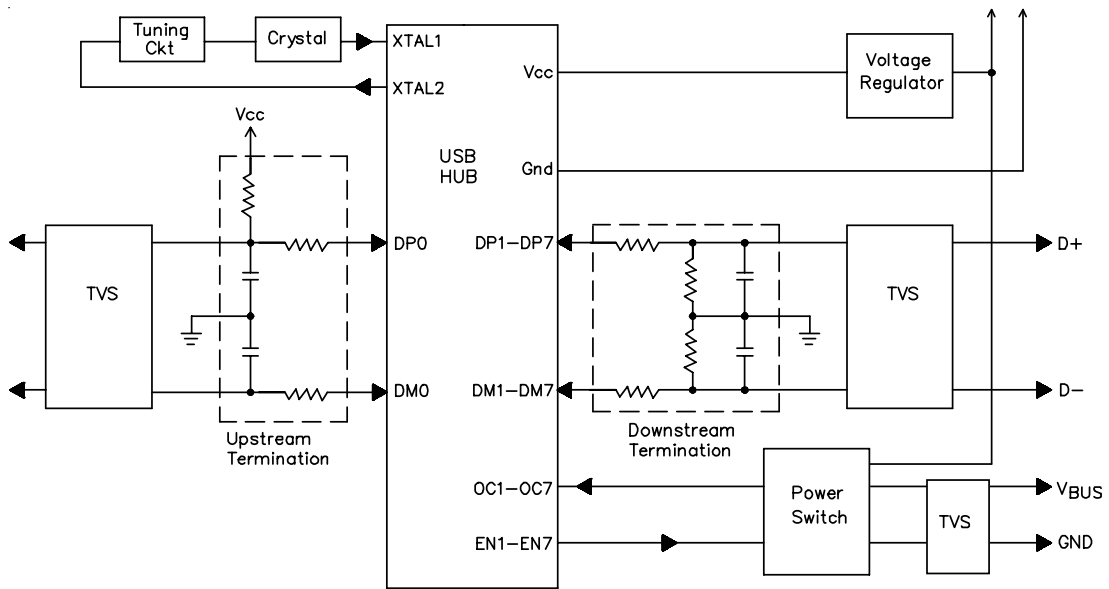

Figure 3 - USB Port Components

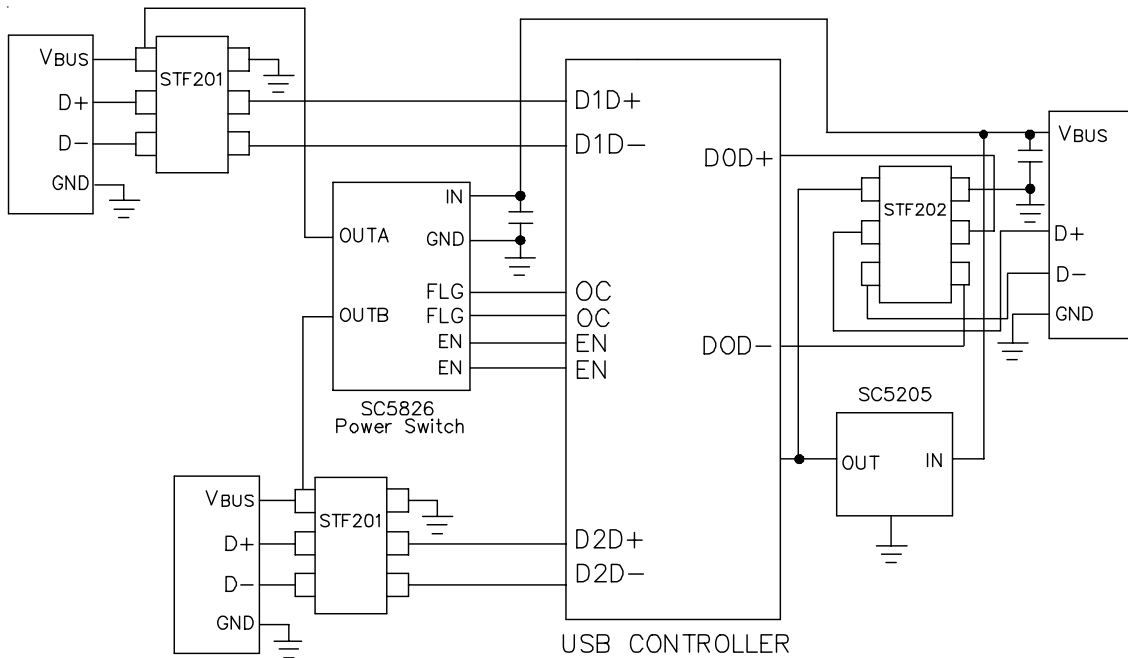
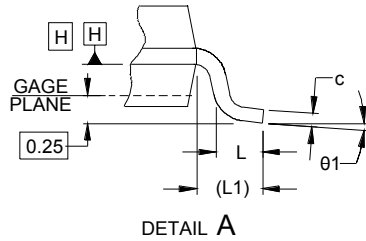
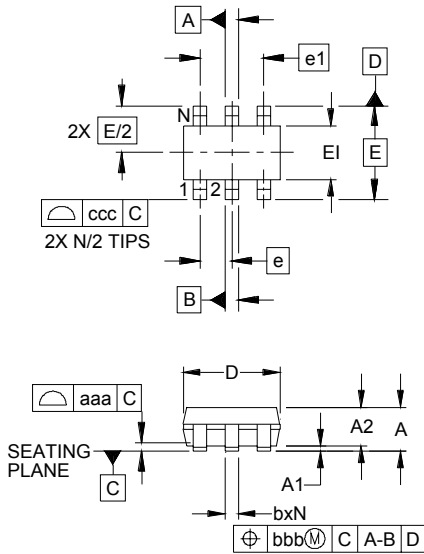

Figure 4 - Typical USB Hub Design

PROTECTION PRODUCTS

Outline Drawing -



DIM	INCHES			MILLIMETERS		
	MIN	NOM	MAX	MIN	NOM	MAX
A	.035	-	.057	0.90	-	1.45
A1	.000	-	.006	0.00	-	0.15
A2	.035	.045	.051	.90	1.15	1.30
b	.010	-	.020	0.25	-	0.50
c	.003	-	.009	0.08	-	0.22
D	.110	.114	.118	2.80	2.90	3.00
E1	.060	.063	.069	1.50	1.60	1.75
E	.110 BSC			2.80 BSC		
e	.037 BSC			0.95 BSC		
e1	.075 BSC			1.90 BSC		
L	.012	.018	.024	0.30	0.45	0.60
L1	(0.24)			(0.60)		
N	6			6		
theta1	0°	-	10°	0°	-	10°
aaa	.004			0.10		
bbb	.008			0.20		
ccc	.008			0.20		

NOTES:

1. CONTROLLING DIMENSIONS ARE IN MILLIMETERS (ANGLES IN DEGREES).
2. DATUMS **-A-** AND **-B-** TO BE DETERMINED AT DATUM PLANE **-H-**
3. DIMENSIONS "E1" AND "D" DO NOT INCLUDE MOLD FLASH, PROTRUSIONS OR GATE BURRS.

Land Pattern -

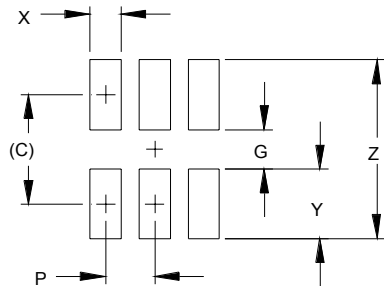

DIMENSIONS		
DIM	INCHES	MILLIMETERS
C	(.098)	(2.50)
G	.055	1.40
P	.037	0.95
X	.024	0.60
Y	.043	1.10
Z	.141	3.60

NOTES:

1. THIS LAND PATTERN IS FOR REFERENCE PURPOSES ONLY. CONSULT YOUR MANUFACTURING GROUP TO ENSURE YOUR COMPANY'S MANUFACTURING GUIDELINES ARE MET.

PROTECTION PRODUCTS**Marking Codes**

Part Number	Marking Code
STF201-22	122
STF201-30	130

Ordering Information

Part Number	Lead Finish	Qty per Reel	Reel Size
STF201-22.TC	SnPb	3,000	7 Inch
STF201-30.TC	SnPb	3,000	7 Inch
STF201-22.TCT	Pb free	3,000	7 Inch
STF201-30.TCT	Pb free	3,000	7 Inch

Contact Information

Semtech Corporation
Protection Products Division
200 Flynn Road, Camarillo, CA 93012
Phone: (805)498-2111 FAX (805)498-3804