

PLEASE CHECK WWW.MOLEX.COM FOR LATEST PART INFORMATION

Part Number: **0438600023**
Status: **Active**
Overview: modular_plugs_jacks
Description: Modular Jack, Right Angle, Low Profile, Inverted, Lightpipes, 6/4, Unshielded

Documents:

[3D Model](#) [Product Specification PS-43860-003 \(PDF\)](#)
[Drawing \(PDF\)](#) [RoHS Certificate of Compliance \(PDF\)](#)
[Application Specification \(PDF\)](#)

Agency Certification

CSA LR19980
 UL E107635

General

Product Family Modular Jacks/Plugs
 Series [43860](#)
 Comments Polysulfone Lightpipes
 Component Type PCB Jack
 Magnetic No
 Overview [modular_plugs_jacks](#)
 Performance Category 3
 Power over Ethernet (PoE) N/A
 Product Name RJ11

Physical

Boot Color N/A
 Color - Resin Black
 Durability (mating cycles max) 500
 Flammability 94V-0
 Inverted / Top Latch Yes
 Keying to Mating Part None
 Lightpipes/LEDs Lightpipes
 Material - Metal Phosphor Bronze
 Material - Plating Mating Gold
 Material - Plating Termination Tin
 Material - Resin High Temperature Thermoplastic, Polysulfone
 Orientation Right Angle (Side Entry)
 PCB Locator Yes
 PCB Retention Yes
 PCB Thickness Recommended (in) 0.062 In
 PCB Thickness Recommended (mm) 1.57 mm
 Packaging Type Tube
 Panel Mount Without Flange
 Pitch - Mating Interface (in) 0.040 In
 Pitch - Mating Interface (mm) 1.02 mm
 Pitch - Term. Interface (in) 0.040 In
 Pitch - Term. Interface (mm) 1.02 mm
 Plating min: Mating (µin) 50
 Plating min: Mating (µm) 1.25
 Plating min: Termination (µin) 100
 Plating min: Termination (µm) 2.5
 Ports 1
 Positions / Loaded Contacts 6/4
 Surface Mount Compatible (SMC) No
 Temperature Range - Operating -40°C to +85°C

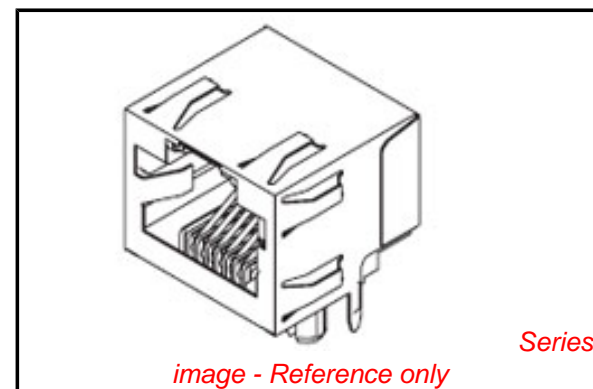

EU RoHS

ELV and RoHS Compliant
REACH SVHC
 Not Reviewed
Halogen-Free Status
 Not Reviewed

China RoHS



Need more information on product environmental compliance?

Email productcompliance@molex.com
 For a multiple part number RoHS Certificate of Compliance, [click here](#)

Please visit the [Contact Us](#) section for any non-product compliance questions.

Search Parts in this Series

[43860Series](#)

Mates With

FCC 68 Plugs

Termination Interface: Style	Through Hole
Waterproof / Dustproof	No
Wire/Cable Type	N/A

Electrical

Current - Maximum per Contact	1.5A
Grounding to PCB	No
Grounding to Panel	None
Shielded	No
Voltage - Maximum	150V AC (RMS)

Solder Process Data

Lead-free Process Capability	Wave Capable (TH only)
------------------------------	------------------------

Material Info**Reference - Drawing Numbers**

Application Specification	AS-43860-001
Packaging Specification	PK-43860-004
Product Specification	PS-43860-003, RPS-43860-004, RPS-43860-007, RPS-43860-008, RPS-43860-013
Sales Drawing	SD-43860-001
Test Summary	TS-43860-001

This document was generated on 06/07/2010

PLEASE CHECK WWW.MOLEX.COM FOR LATEST PART INFORMATION

NOTES:

- 1) MATERIAL:
HOUSING: NYLON(PA), GLASS FILLED, UL94V-0, COLOR: SEE CHART
TERMINALS: PHOSPHOR BRONZE
- 2) FINISH:
TERMINALS:
SELECT GOLD IN CONTACT AREA: 50 MICROINCHES (1.27 MICROMETERS) MIN.
*SELECT TIN IN PC TAIL AREA: 100 MICROINCHES (2.54 MICROMETERS) MIN.,
WITH OVERALL NICKEL UNDERPLATE: 50 MICROINCHES (1.27 MICROMETERS) MIN.
*THE PRIMARY SHIPPING CARTON WILL BE LABELED "COMPLIANT TO
RoHS DIRECTIVE 2002/95/EC AND ELV ANNEX II OF DIRECTIVE
2000/53/EC". CARTONS WITHOUT THIS LABEL MAY CONTAIN PRODUCT
WITH TIN-LEAD IN THE PC TAILS.
- 3) PRODUCT SPECIFICATION AND PROCESSING PARAMETERS: PS-43860-003.
- 4) PACKAGING SPECIFICATION:
CONNECTOR ASSEMBLIES PACKAGED IN EXTRUDED TUBES PER MOLEX
PACKAGING SPECIFICATION PK-43860-004.
- 5) ALL UNTOLERANCED DIMENSIONS ARE SHOWN FOR REFERENCE ONLY.
- 6) CONFORMS TO FCC REGULATION PART 68.5 FOR MODULAR JACKS.
- 7) THIS PART CONFORMS TO CLASS B REQUIREMENTS OF COSMETIC
SPECIFICATION PS-45499-002.

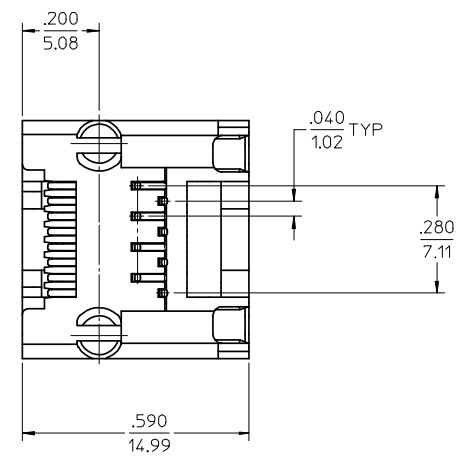
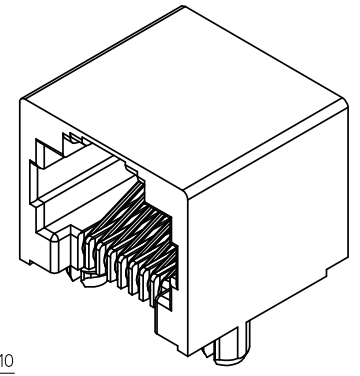
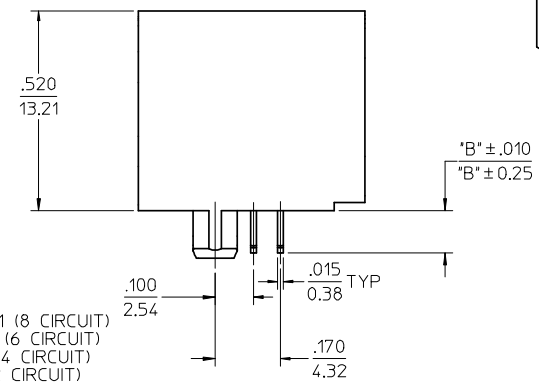
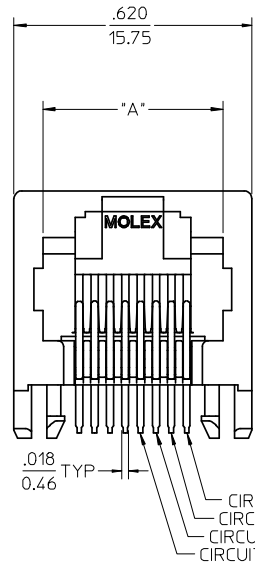
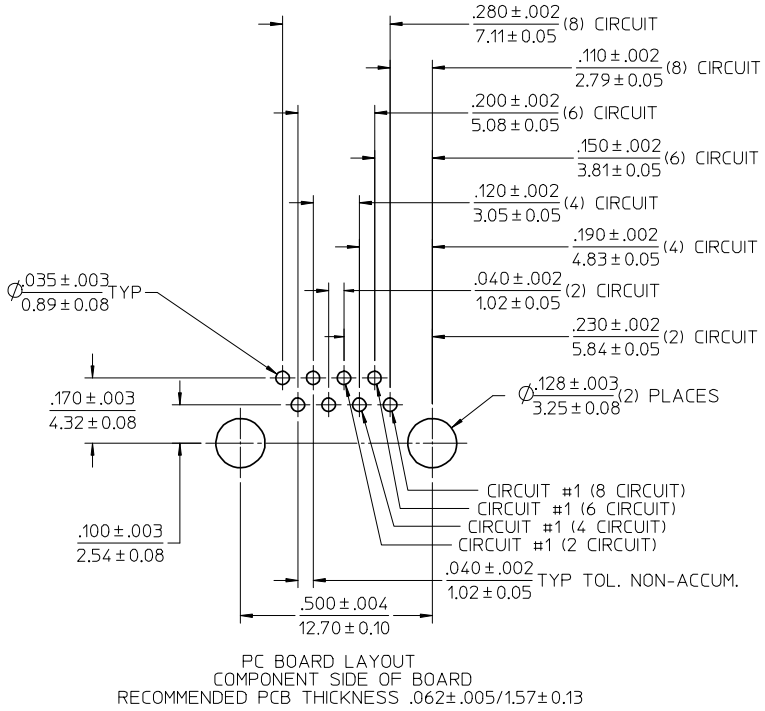

ASSEMBLY MAT. NUM.	CONNECTOR SIZE	DIM "A"	DIM "B"	CIRCUITS	HOUSING COLOR
43860-0001	8	.469/11.91	.110/2.79	8	BLACK
43860-2001	8	.469/11.91	.080/2.03	8	BLACK
43860-0002	6	.389/9.88	.110/2.79	6	BLACK
43860-0003	6	.389/9.88	.110/2.79	4	BLACK
43860-0019	8	.469/11.91	.110/2.79	4	BLACK
43860-0020	6	.389/9.88	.110/2.79	2	BLACK

ADD PART #, SHT 2	EC NO: UCP2008-3111	DRWN: SCHMIDT 2008/06/20	CHKD: BELL 2008/06/27	APPR: FSMTH 2008/07/14
REV	H6	DESCRIPTION	QUALITY SYMBOLS	$\nabla = 0$ $\nabla = 0$

GENERAL TOLERANCES (UNLESS SPECIFIED)	DIMENSION STYLE IN/MM	SCALE 4:1	DESIGN UNITS INCH	THIRD ANGLE PROJECTION															
<table border="1"> <tr> <th></th> <th>mm</th> <th>INCH</th> </tr> <tr> <td>4 PLACES</td> <td>± .005</td> <td>± .001</td> </tr> <tr> <td>3 PLACES</td> <td>± .004</td> <td>± .010</td> </tr> <tr> <td>2 PLACES</td> <td>± 0.25</td> <td>± .010</td> </tr> <tr> <td>1 PLACE</td> <td>± .005</td> <td>± .010</td> </tr> </table>		mm	INCH	4 PLACES	± .005	± .001	3 PLACES	± .004	± .010	2 PLACES	± 0.25	± .010	1 PLACE	± .005	± .010	DRAWN BY TALEND CHECKED BY ROBERTS APPROVED BY FRY	DATE 1997/02/13 DATE 1997/03/03 DATE 1997/03/04	TITLE INVERTED MODULAR JACK ASSEMBLY	
	mm	INCH																	
4 PLACES	± .005	± .001																	
3 PLACES	± .004	± .010																	
2 PLACES	± 0.25	± .010																	
1 PLACE	± .005	± .010																	
ANGULAR ±1/2°	MATERIAL NO. SEE CHART		DOCUMENT NO. SD-43860-001																
DRAFT WHERE APPLICABLE MUST REMAIN WITHIN DIMENSIONS	SIZE C		SHEET NO. 1 OF 5																

MATERIAL NO. SEE CHART		DOCUMENT NO. SD-43860-001		SHEET NO. 1 OF 5	
THIS DRAWING CONTAINS INFORMATION THAT IS PROPRIETARY TO MOLEX INCORPORATED AND SHOULD NOT BE USED WITHOUT WRITTEN PERMISSION					

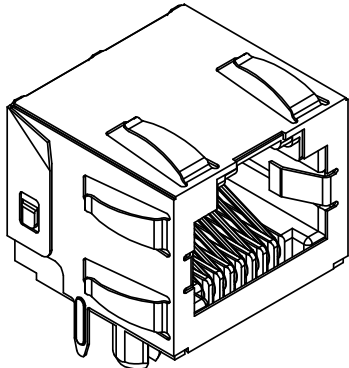

- NOTES:
- MATERIAL:
HOUSING: NYLON(PA), GLASS FILLED, UL94V-0,
COLOR: BLACK
TERMINALS: PHOSPHOR BRONZE
SHIELD: BRASS
 - FINISH:
TERMINALS:
SELECT GOLD IN CONTACT AREA: 50 MICROINCHES/
1.27 MICROMETERS MIN.
*SELECT TIN IN PC TAIL AREA: 100 MICROINCHES/
2.54 MICROMETERS MIN.,
WITH OVERALL NICKEL UNDERPLATE: 50 MICROINCHES/
1.27 MICROMETERS MIN.
SHIELD:
*100 MICROINCHES/2.54 MICROMETERS NICKEL OVER
50 MICROINCHES/1.27 MICROMETERS COPPER
UNDERPLATE, PCB GROUND TABS DIPPED IN TIN
*THE PRIMARY SHIPPING CARTON WILL BE LABELED
"COMPLIANT TO RoHS DIRECTIVE 2002/95/EC AND
ELV ANNEX II OF DIRECTIVE 2000/53/EC".
CARTONS WITHOUT THIS LABEL MAY CONTAIN
PRODUCT WITH TIN-LEAD IN THE PC TAILS AND/OR SHIELD.
 - PRODUCT SPECIFICATION: PS-43860-003.
 - PACKAGING SPECIFICATION:
CONNECTOR ASSEMBLIES PACKAGED IN THERMOFORMED TRAYS
PER MOLEX PACKAGING SPECIFICATION PK-43860-005.
43860-5025 CONNECTOR ASSEMBLIES PACKAGED IN TAPE AND
REEL PER MOLEX PACKAGING SPECIFICATION PK-70873-700*
 - ALL UNTOLERANCED DIMENSIONS ARE SHOWN FOR REFERENCE ONLY.
 - CONFORMS TO FCC REGULATION PART 68.5 FOR MODULAR JACKS.
 - AVAILABLE WITH THE (2) SPECIFIED PANEL GROUND TABS
OMITTED FOR SIDE TO SIDE STACKABILITY, PER THE ASSEMBLY
MATERIAL NUMBER TABLE.
 - AVAILABLE WITH TOP PANEL GROUND TABS ONLY, PER THE
ASSEMBLY MATERIAL NUMBER TABLE.
 - THIS PART CONFORMS TO CLASS B REQUIREMENTS OF COSMETIC
SPECIFICATION PS-45499-002.

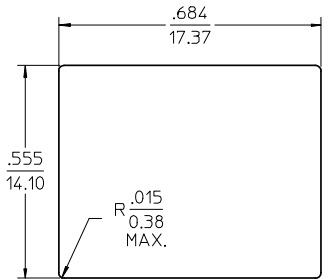
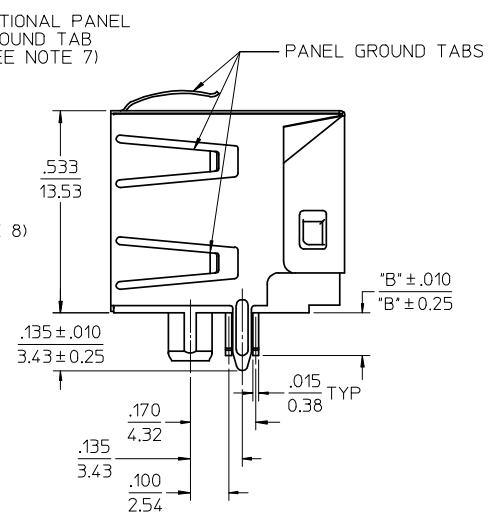
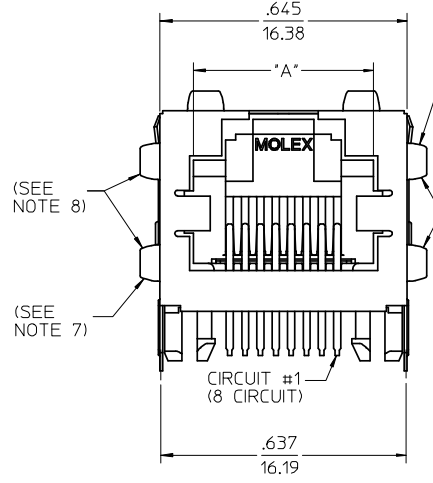
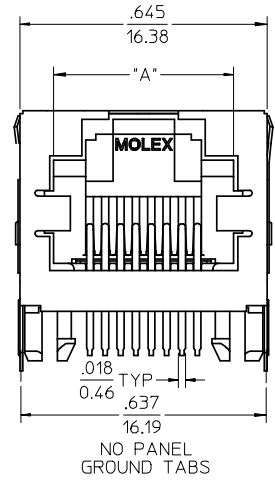

RECOMMENDED
PANEL
OPENING

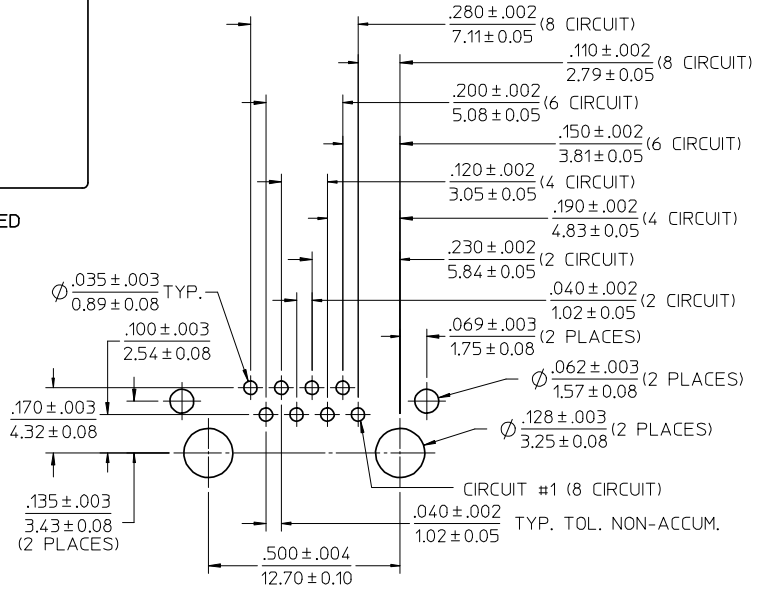

PC BOARD LAYOUT
COMPONENT SIDE OF BOARD
RECOMMENDED PCB THICKNESS .062 ± .005/1.57 ± 0.13

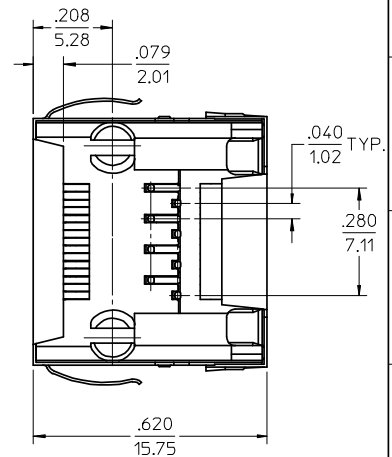

ASSEMBLY MAT. NUM.	CONNECTOR SIZE	DIM "A"	DIM "B"	CIRCUITS	PANEL GROUND TABS	PACKAGING OPTION
43860-0004	8	.469/11.91	.110/2.79	8	ALL	TRAY
43860-2004	8	.469/11.91	.080/2.03	8	ALL	TRAY
43860-0005	6	.389/9.88	.110/2.79	6	ALL	TRAY
43860-0006	6	.389/9.88	.110/2.79	4	ALL	TRAY
43860-0013	8	.469/11.91	.110/2.79	8	SEE NOTE #7	TRAY
43860-0014	6	.389/9.88	.110/2.79	6	SEE NOTE #7	TRAY
43860-0015	6	.389/9.88	.110/2.79	4	SEE NOTE #7	TRAY
43860-0024	6	.389/9.88	.110/2.79	2	ALL	TRAY
43860-0025	8	.469/11.91	.110/2.79	8	NONE	TRAY
43860-0026	6	.389/9.88	.110/2.79	6	NONE	TRAY
43860-0027	6	.389/9.88	.110/2.79	4	NONE	TRAY
43860-0031	8	.469/11.91	.110/2.79	8	SEE NOTE #8	TRAY
43860-5025	8	.469/11.91	.110/2.79	8	NONE	TAPE

ADD 43860-5025 EC NO: UCP2008-3111 DRAWN: SCHMIDT 2008/06/20 CHKD: JEBEL 2008/06/27 APPR: FSM/TH 2008/07/14	QUALITY SYMBOLS ▽=0 ▽=0	GENERAL TOLERANCES (UNLESS SPECIFIED) mm INCH 4 PLACES ± --- ± --- 3 PLACES ± --- ± .010 2 PLACES ± 0.25 ± --- 1 PLACE ± --- ± --- ANGULAR ± 1/2°	DIMENSION STYLE IN/MM DRAWN BY DATE TALEND 1997/02/13 CHECKED BY DATE ROBERTS 1997/03/03 APPROVED BY DATE FRY 1997/03/04	SCALE 4:1 DESIGN UNITS INCH THIRD ANGLE PROJECTION	TITLE INVERTED MODULAR JACK ASSEMBLY	MATERIAL NO. SEE CHART DOCUMENT NO. SD-43860-001 SHEET NO. 2 OF 5
	DRAFT WHERE APPLICABLE MUST REMAIN WITHIN DIMENSIONS		THIS DRAWING CONTAINS INFORMATION THAT IS PROPRIETARY TO MOLEX INCORPORATED AND SHOULD NOT BE USED WITHOUT WRITTEN PERMISSION			

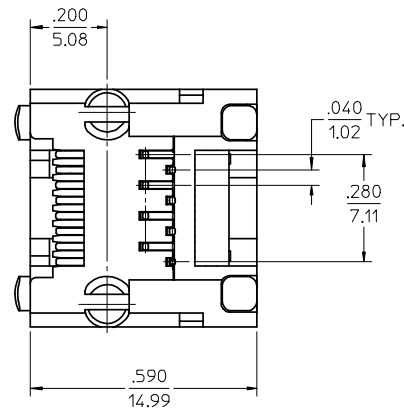
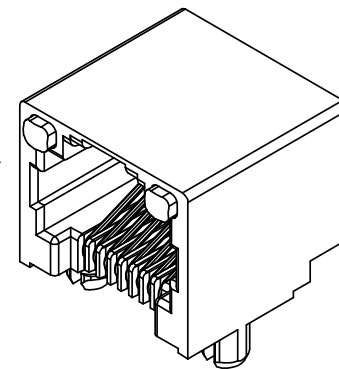
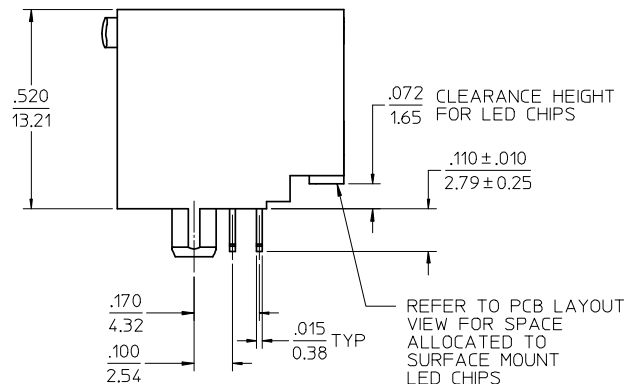
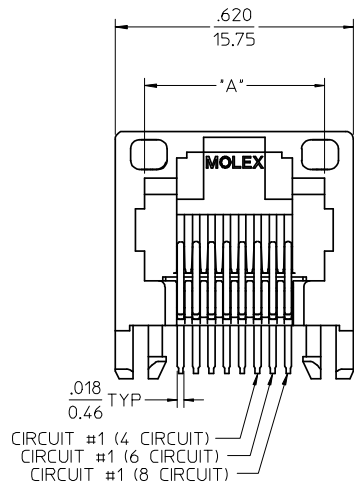

NOTES:

- 1) MATERIAL:
 HOUSING: NYLON(PA), GLASS FILLED, UL94V-0, COLOR: BLACK
 TERMINALS: PHOSPHOR BRONZE
 LIGHT PIPES: POLYCARBONATE - WAVE OR HAND SOLDER ONLY (NOT DESIGNED FOR I/R REFLOW OR CONVECTION REFLOW SOLDER PROCESSES)
 POLYSULFONE - MAXIMUM REFLOW TEMPERATURE 400°F (205°C)
- 2) FINISH:
 TERMINALS:
 SELECT GOLD IN CONTACT AREA: 50 MICROINCHES (1.27 MICROMETERS) MIN.,
 *SELECT TIN IN PC TAIL AREA: 100 MICROINCHES (2.54 MICROMETERS) MIN.,
 WITH OVERALL NICKEL UNDERPLATE: 50 MICROINCHES (1.27 MICROMETERS) MIN.
 *THE PRIMARY SHIPPING CARTON WILL BE LABELED "COMPLIANT TO RoHS DIRECTIVE 2002/95/EC AND ELV ANNEX II OF DIRECTIVE 2000/53/EC". CARTONS WITHOUT THIS LABEL MAY CONTAIN PRODUCT WITH TIN-LEAD IN THE PC TAILS.
- 3) PRODUCT SPECIFICATION AND PROCESSING PARAMETERS: PS-43860-003.
- 4) PACKAGING SPECIFICATION:
 CONNECTOR ASSEMBLIES PACKAGED IN EXTRUDED TUBES PER MOLEX PACKAGING SPECIFICATION PK-43860-004.
- 5) APPLICATION SPECIFICATION: AS-43860-001
- 6) ALL UNTOLERANCED DIMENSIONS ARE SHOWN FOR REFERENCE ONLY.
- 7) CONFORMS TO FCC REGULATION PART 68.5 FOR MODULAR JACKS.
- 8) REFER TO SHEET (5) OF (5) FOR RECOMMENDED PCB LAYOUT.
- 9) THIS PART CONFORMS TO CLASS B REQUIREMENTS OF COSMETIC SPECIFICATION PS-45499-002.

ASSEMBLY MAT. NUM.	LIGHT PIPE MATERIAL	CONNECTOR SIZE	DIM "A"	CIRCUITS
43860-0007	POLYCARBONATE	8	.469/11.91	8
43860-0008	POLYCARBONATE	6	.389/9.88	6
43860-0009	POLYCARBONATE	6	.389/9.88	4
43860-0021	POLYSULFONE	8	.469/11.91	8
43860-0022	POLYSULFONE	6	.389/9.88	6
43860-0023	POLYSULFONE	6	.389/9.88	4

SEE SHEET 1 EC NO: UCP2008-3111 DRWNL: SCHMIDT 2008/06/20 CHKD: JEBEL 2008/06/27 APPR: FSMITH 2008/07/14 H6	QUALITY SYMBOLS ▽=0 ▽=0	GENERAL TOLERANCES (UNLESS SPECIFIED) <table border="1"> <tr> <th></th> <th>mm</th> <th>INCH</th> </tr> <tr> <td>4 PLACES</td> <td>± .010</td> <td>± .0004</td> </tr> <tr> <td>3 PLACES</td> <td>± .010</td> <td>± .0004</td> </tr> <tr> <td>2 PLACES</td> <td>± 0.25</td> <td>± .010</td> </tr> <tr> <td>1 PLACE</td> <td>± .010</td> <td>± .0004</td> </tr> </table>		mm	INCH	4 PLACES	± .010	± .0004	3 PLACES	± .010	± .0004	2 PLACES	± 0.25	± .010	1 PLACE	± .010	± .0004	DIMENSION STYLE IN/MM	SCALE 4:1	DESIGN UNITS INCH	THIRD ANGLE PROJECTION
		mm	INCH																		
	4 PLACES	± .010	± .0004																		
	3 PLACES	± .010	± .0004																		
2 PLACES	± 0.25	± .010																			
1 PLACE	± .010	± .0004																			
		DRAWN BY TALEND	DATE 1997/02/13	TITLE INVERTED MODULAR JACK ASSEMBLY																	
		CHECKED BY ROBERTS	DATE 1997/03/03	MOLEX MOLEX INCORPORATED																	
		APPROVED BY FRY	DATE 1997/03/04	MATERIAL NO. SEE CHART	DOCUMENT NO. SD-43860-001	SHEET NO. 3 OF 5															

DRAFT WHERE APPLICABLE MUST REMAIN WITHIN DIMENSIONS

THIS DRAWING CONTAINS INFORMATION THAT IS PROPRIETARY TO MOLEX INCORPORATED AND SHOULD NOT BE USED WITHOUT WRITTEN PERMISSION

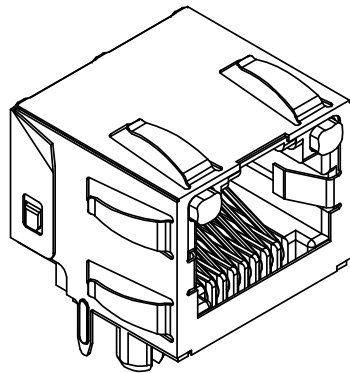

OPTIONAL PANEL GROUND TAB (SEE NOTE 8)

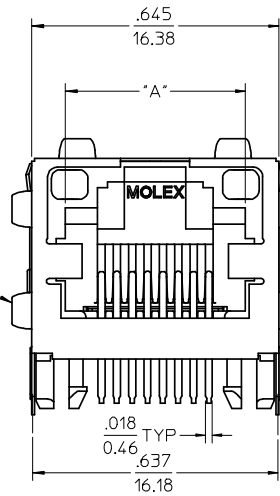

OPTIONAL PANEL GROUND TAB (SEE NOTE 8)

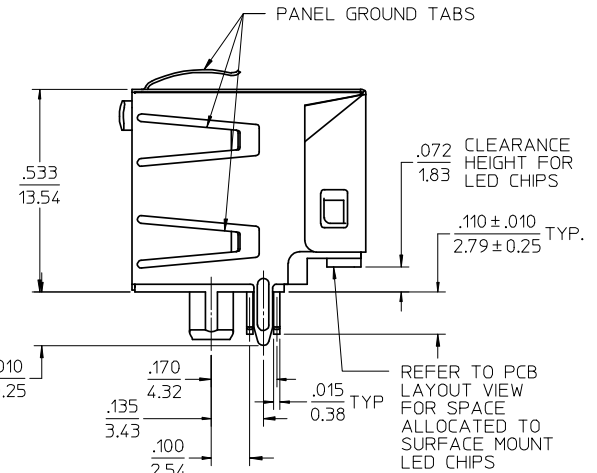

REFER TO PCB LAYOUT VIEW FOR SPACE ALLOCATED TO SURFACE MOUNT LED CHIPS

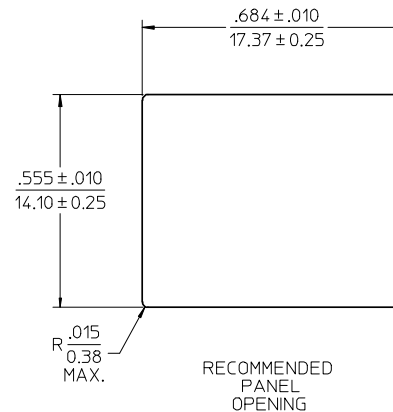

RECOMMENDED PANEL OPENING

- NOTES:
- MATERIAL: HOUSING: NYLON(PA), GLASS FILLED, UL94V-0, COLOR: BLACK
TERMINALS: PHOSPHOR BRONZE
SHIELD: BRASS
LIGHT PIPES: POLYCARBONATE - WAVE OR HAND SOLDER ONLY (NOT DESIGNED FOR I/R REFLOW OR CONVECTION REFLOW SOLDER PROCESSES), POLYSULFONE - MAXIMUM REFLOW TEMPERATURE 400°F (205°C)
 - FINISH: TERMINALS: SELECT GOLD IN CONTACT AREA: 50 MICROINCHES/1.27 MICROMETERS MIN., SELECT TIN IN PC TAIL AREA: 100 MICROINCHES/2.54 MICROMETERS MIN., WITH OVERALL NICKEL UNDERPLATE: 50 MICROINCHES/1.27 MICROMETERS MIN. SHIELD: *100 MICROINCHES/2.54 MICROMETERS OVER 50 MICROINCHES/1.27 MICROMETERS COPPER UNDERPLATE, PCB GROUND TABS DIPPED IN TIN *THE PRIMARY SHIPPING CARTON WILL BE LABELED 'COMPLIANT TO RoHS DIRECTIVE 2002/95/EC AND ELV ANNEX II OF DIRECTIVE 2000/53/EC'. CARTONS WITHOUT THIS LABEL MAY CONTAIN PRODUCT WITH TIN-LEAD IN THE PC TAILS AND/OR SHIELD.
 - PRODUCT SPECIFICATION AND PROCESSING PARAMETERS: PS-43860-003.
 - PACKAGING SPECIFICATION: CONNECTOR ASSEMBLIES PACKAGED IN THERMOFORMED TRAYS PER MOLEX PACKAGING SPECIFICATION PK-43860-005.
 - APPLICATION SPECIFICATION: AS-43860-001
 - ALL UNTOLERANCED DIMENSIONS ARE SHOWN FOR REFERENCE ONLY.
 - CONFORMS TO FCC REGULATION PART 68.5 FOR MODULAR JACKS.
 - AVAILABLE WITH THE (2) SPECIFIED PANEL GROUND TABS OMITTED FOR SIDE TO SIDE STACKABILITY, PER THE ASSEMBLY MATERIAL NUMBER TABLE.
 - REFER TO SHEET (5) OF (5) FOR RECOMMENDED PCB LAYOUT.
 - THIS PART CONFORMS TO CLASS B REQUIREMENTS OF COSMETIC SPECIFICATION PS-45499-002.

ASSEMBLY MAT. NUM.	LIGHT PIPE MATERIAL	CONNECTOR SIZE	DIM "A"	CIRCUITS	PANEL GROUND TABS
43860-0010	POLYCARBONATE	8	.469/11.91	8	ALL
43860-0011	POLYCARBONATE	6	.389/9.88	6	ALL
43860-0012	POLYCARBONATE	6	.389/9.88	4	ALL
43860-0016	POLYCARBONATE	8	.469/11.91	8	SEE NOTE #8
43860-0017	POLYCARBONATE	6	.389/9.88	6	SEE NOTE #8
43860-0018	POLYCARBONATE	6	.389/9.88	4	SEE NOTE #8
43860-1010	POLYSULFONE	8	.469/11.91	8	ALL
43860-1011	POLYSULFONE	6	.389/9.88	6	ALL
43860-1012	POLYSULFONE	6	.389/9.88	4	ALL
43860-1016	POLYSULFONE	8	.469/11.91	8	SEE NOTE #8
43860-1017	POLYSULFONE	6	.389/9.88	6	SEE NOTE #8
43860-1018	POLYSULFONE	6	.389/9.88	4	SEE NOTE #8

SEE SHEET 1 EC NO: UCP2008-3111 DRAWN: SCHMIDT 2008/06/20 CHKD: JEBEL 2008/06/27 APPR: FSM/TH 2008/07/14	QUALITY SYMBOLS ▽=0 ▽=0	GENERAL TOLERANCES (UNLESS SPECIFIED) <table border="1"> <tr> <th></th> <th>mm</th> <th>INCH</th> </tr> <tr> <td>4 PLACES ±</td> <td>---</td> <td>±---</td> </tr> <tr> <td>3 PLACES ±</td> <td>---</td> <td>±.010</td> </tr> <tr> <td>2 PLACES ±</td> <td>0.25</td> <td>±---</td> </tr> <tr> <td>1 PLACE ±</td> <td>---</td> <td>±---</td> </tr> </table>		mm	INCH	4 PLACES ±	---	±---	3 PLACES ±	---	±.010	2 PLACES ±	0.25	±---	1 PLACE ±	---	±---	DIMENSION STYLE IN/MM	SCALE 4:1	DESIGN UNITS INCH	THIRD ANGLE PROJECTION
				mm	INCH																
4 PLACES ±	---	±---																			
3 PLACES ±	---	±.010																			
2 PLACES ±	0.25	±---																			
1 PLACE ±	---	±---																			
DRAFT WHERE APPLICABLE MUST REMAIN WITHIN DIMENSIONS	MATERIAL NO. SEE CHART	DRAWN BY TALEND	DATE 1997/02/13	CHECKED BY ROBERTS	DATE 1997/03/03	APPROVED BY FRY	DATE 1997/03/04														
H6		MOLEX INCORPORATED		DOCUMENT NO. SD-43860-001		SHEET NO. 4 OF 5															
THIS DRAWING CONTAINS INFORMATION THAT IS PROPRIETARY TO MOLEX INCORPORATED AND SHOULD NOT BE USED WITHOUT WRITTEN PERMISSION																					

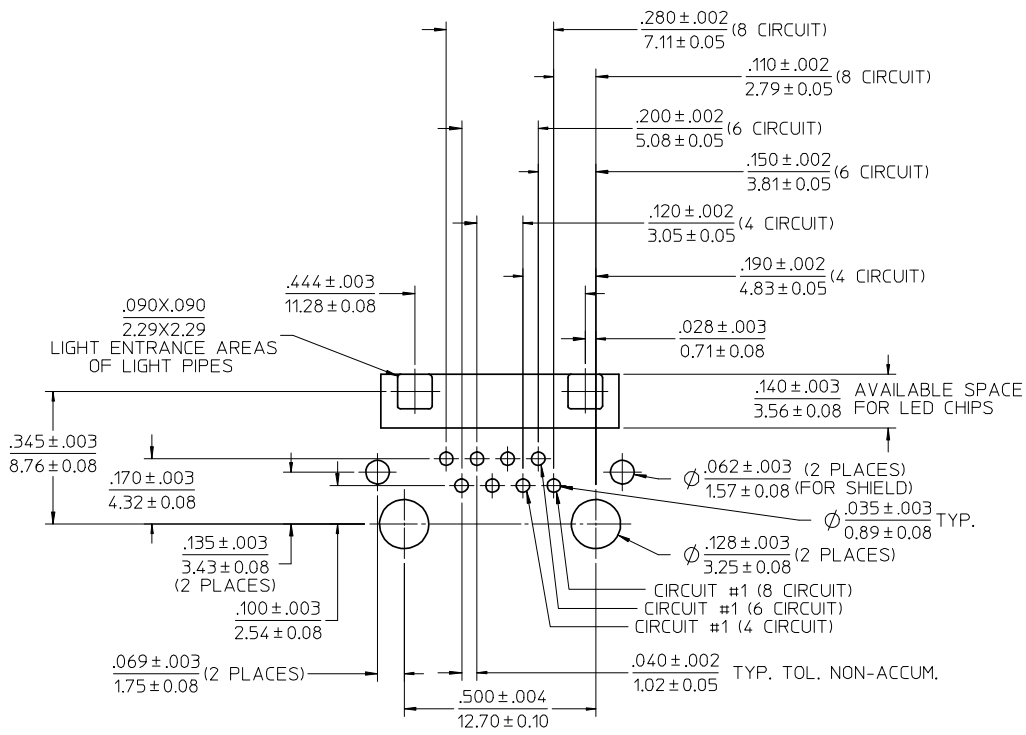

MOLEX RECOMMENDED
PC BOARD LAYOUT
COMPONENT SIDE OF BOARD
RECOMMENDED PCB THICKNESS .062±.005/1.57±.013

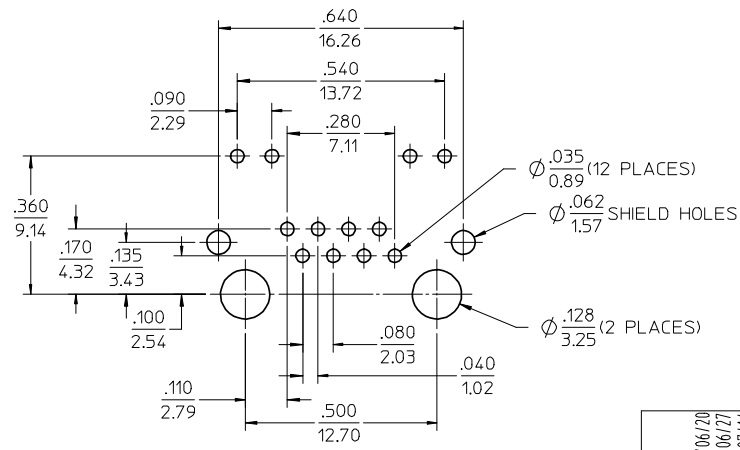

TYPICAL COMPETITION
PCB LAYOUT WITH
INTEGRAL LED'S
(SHOWN FOR REFERENCE ONLY)

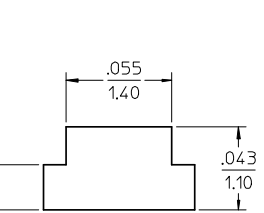
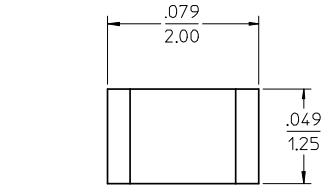

RECOMMENDED SMT
0805 LED DIMENSIONS
SCALE 20:1
(SEE NOTE 1)

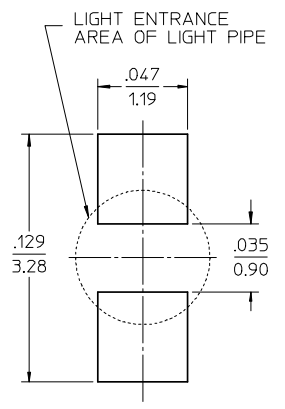

RECOMMENDED SMT
0805 LED SOLDER PATTERN
SCALE 20:1
(SEE NOTE 1)

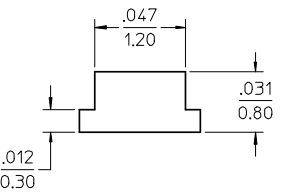
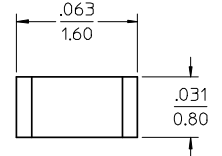

RECOMMENDED SMT
0603 LED DIMENSIONS
SCALE 20:1
(SEE NOTE 1)

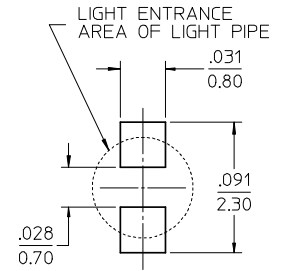

RECOMMENDED SMT
0603 LED SOLDER PATTERN
SCALE 20:1
(SEE NOTE 1)

NOTES:
1. FOR CROSS REFERENCE OF RECOMMENDED LED'S SEE MOLEX WEB SITE

SEE SHEET 1 EC NO: UCP2008-3111 DRAWN: SCHMIDT 2008/06/20 CHKD: JEBEL 2008/06/27 APPR: FSMITH 2008/07/14	QUALITY SYMBOLS ▽=0 ▽=0	GENERAL TOLERANCES (UNLESS SPECIFIED)		DIMENSION STYLE IN/MM		SCALE 4:1	DESIGN UNITS INCH	THIRD ANGLE PROJECTION	
H6	REV	DRAWN BY TALEND		DATE 1997/02/13		TITLE INVERTED MODULAR JACK ASSEMBLY			
		CHECKED BY ROBERTS		DATE 1997/03/03					
		APPROVED BY FRY		DATE 1997/03/04		MOLEX INCORPORATED DOCUMENT NO. SD-43860-001 SHEET NO. 5 OF 5			
		MATERIAL NO.		SEE CHART					
		DRAFT WHERE APPLICABLE MUST REMAIN WITHIN DIMENSIONS		SIZE C		THIS DRAWING CONTAINS INFORMATION THAT IS PROPRIETARY TO MOLEX INCORPORATED AND SHOULD NOT BE USED WITHOUT WRITTEN PERMISSION			