

PLEASE CHECK WWW.MOLEX.COM FOR LATEST PART INFORMATION

Part Number: [0190730022](#)
Status: **Active**
Description: Avikrimp™ Ring Tongue Terminal for 18 to 22 AWG Wire, Stud Size 10, Length 26.90mm (1.059")

Documents:

[Drawing \(PDF\)](#) [RoHS Certificate of Compliance \(PDF\)](#)

Agency Certification

CSA LR18689
 UL E32244

General

Product Family Ring and Spade Terminals
 Series [19073](#)
 Crimp Quality Equipment Yes
 Mil-Spec N/A
 Product Name Avikrimp™
 Type Ring

Physical

Barrel Type Closed
 Flammability 94V-0
 Insulation Nylon (PA)
 Material - Plating Mating Tin
 Packaging Type Bag
 Stud Size 10 (M5)
 Termination Interface: Style Crimp or Compression
 Wire Insulation Diameter 3.56mm (.140") max.
 Wire Size AWG 18, 20, 22
 Wire Size mm² 0.25 - 1.50

Material Info

Old Part Number AA-822-10

Reference - Drawing Numbers

Sales Drawing SD-19073-003

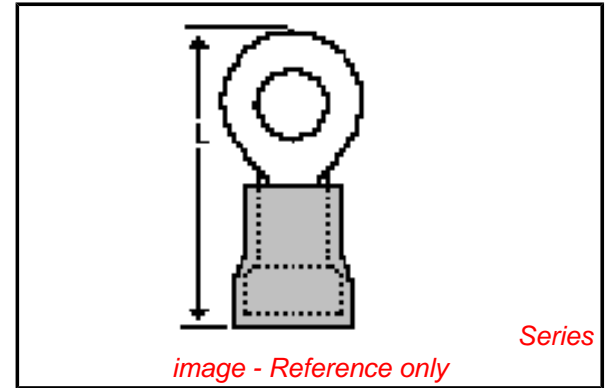

EU RoHS

ELV and RoHS Compliant
REACH SVHC
 Not Reviewed
Halogen-Free Status
 Not Reviewed

China RoHS



Need more information on product environmental compliance?

Email productcompliance@molex.com
 For a multiple part number RoHS Certificate of Compliance, [click here](#)

Please visit the [Contact Us](#) section for any non-product compliance questions.

Search Parts in this Series

[19073Series](#)

Application Tooling | [FAQ](#)

Tooling specifications and manuals are found by selecting the products below. Crimp Height Specifications are then contained in the Application Tooling Specification document.

Global

Description	Product #
Hand Crimp Tool	0640010100
Hand Crimp Tool	0640011200
Crimp Head for the AT-200™ Pneumatic Hand Tool	0640050100
Crimp Head for the AT-200™ Pneumatic Hand Tool	0640051200

MATERIAL NUMBER	ALTERNATE NUMBER	STUD SIZE	"S"	"W"	"C"	"L"	"I.D."	H ±.010/0.25	PACKAGING
190730022	AA-822-10	10	.198(5.03)	.47(11.9)	.39(9.8)	1.06(26.9)	.062(1.57)	N/A	LOOSE PIECE
190730024	AA-822-14	1/4	.265(6.73)	.47(11.9)	.39(9.8)	1.06(26.9)	.062(1.57)		
190730027	AA-822-56	5/16	.328(8.33)	.47(11.9)	.39(9.8)	1.06(26.9)	.062(1.57)		
190730029	AA-826-10	10	.198(5.03)	.54(13.6)	.55(14.0)	1.26(32.0)	.054(1.37)		
190730030	AA-826-14	1/4	.265(6.73)	.54(13.6)	.55(14.0)	1.26(32.0)	.054(1.37)		
190730032	AA-826-38	3/8	.390(9.91)	.54(13.6)	.55(14.0)	1.26(32.0)	.054(1.37)		
190730034	AA-826-56	5/16	.328(8.33)	.54(13.6)	.55(14.0)	1.26(32.0)	.054(1.37)	TAPE MOUNTED	
190730023	AA-822-10T	10	.198(5.03)	.47(11.9)	.39(9.8)	1.06(26.9)	.062(1.57)		
190730339	AA-822-10BT	10	.198(5.03)	.47(11.9)	.39(9.8)	1.06(26.9)	.062(1.57)		
190730026	AA-822-14T	1/4	.265(6.73)	.47(11.9)	.39(9.8)	1.06(26.9)	.062(1.57)		
190730028	AA-822-56T	5/16	.328(8.33)	.47(11.9)	.39(9.8)	1.06(26.9)	.062(1.57)		
190730319	AA-826-10T	10	.198(5.03)	.54(13.6)	.55(14.0)	1.26(32.0)	.054(1.37)		
190730031	AA-826-14T	1/4	.265(6.73)	.54(13.6)	.55(14.0)	1.26(32.0)	.054(1.37)		
190730033	AA-826-38T	3/8	.390(9.91)	.54(13.6)	.55(14.0)	1.26(32.0)	.054(1.37)		
190730035	AA-826-56T	5/16	.328(8.33)	.54(13.6)	.55(14.0)	1.26(32.0)	.054(1.37)		

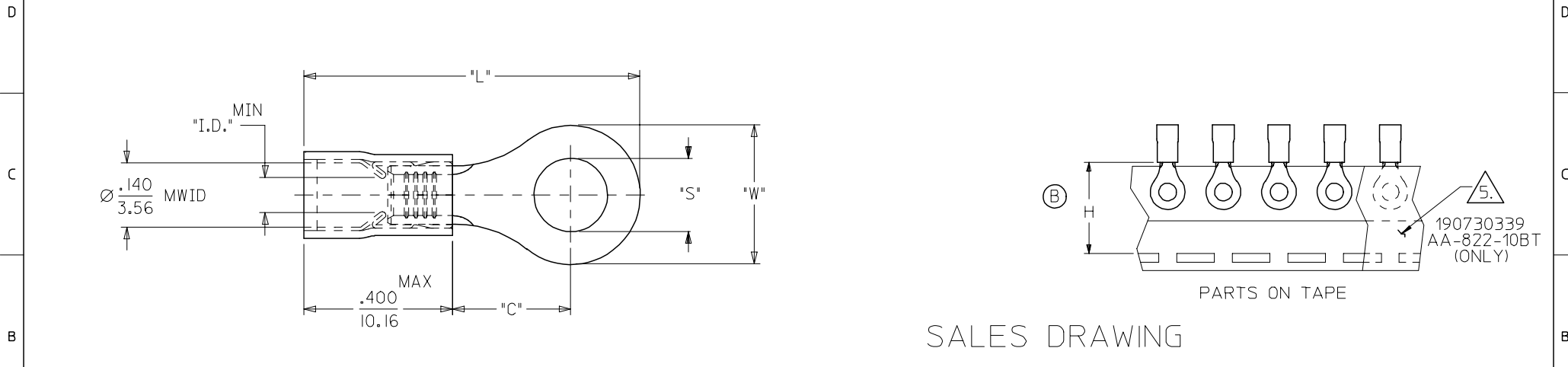

SALES DRAWING

NOTES:
 1. MATERIAL: COPPER
 PLATING: ELECTROPLATE TIN
 2. FERRULE: TIN-PLATED BRASS
 3. INSULATION: RED NYLON
 4. MWID=MAXIMUM WIRE INSULATION DIA.
 5. INTERLEAF PAPER (191660010, 24613) IS REQUIRED ON 190730339, AA-822-10BT REELS.

ADD'D 190730339 EC NO: ETC2005-0137 DRW/BENDERLE 2005/02/15 CHK'DR DEROSS 2005/02/15 APPR:RDEROSS 2005/02/15	QUALITY SYMBOLS	GENERAL TOLERANCES (UNLESS SPECIFIED)	DIMENSION STYLE	SCALE	DESIGN UNITS	THIRD ANGLE PROJECTION
	▽=0 ▽=0	mm INCH 4 PLACES ± --- ± --- 3 PLACES ± --- ± --- 2 PLACES ± --- ± --- 1 PLACE ± --- ± --- ANGULAR ± ---°	IN/MM	NONE	INCH	
	DESCRIPTION	DRAFT WHERE APPLICABLE MUST REMAIN WITHIN DIMENSIONS	DRAWN BY DATE	TITLE		
	REV		HEB 2000/09/08	RING TONGUE TERMINAL 22-18 AVIKRIMP, 800-SERIES		
			CHECKED BY DATE	MOLEX INCORPORATED		
			RWD 2000/09/08	SD-19073-003		
			APPROVED BY DATE	SHEET NO.		
			RWD 2000/09/08	1 OF 1		
			MATERIAL NO.	DOCUMENT NO.		
			SEE CHART	SD-19073-003		
			SIZE	THIS DRAWING CONTAINS INFORMATION THAT IS PROPRIETARY TO MOLEX INCORPORATED AND SHOULD NOT BE USED WITHOUT WRITTEN PERMISSION		
			B			