

PLEASE CHECK WWW.MOLEX.COM FOR LATEST PART INFORMATION

Part Number: [5023070111](#)
Status: **Active**
Overview: [ctx crimp terminals](#)
Description: CTX150 Female Terminal, Tin (Sn), 22 AWG D-Wind, Left Payoff, Grip Code S

Documents:

[Drawing \(PDF\)](#) [RoHS Certificate of Compliance \(PDF\)](#)

General

Product Family Crimp Terminals
 Series [502307](#)
 Crimp Quality Equipment Yes
 Overview [ctx crimp terminals](#)
 Product Name CTX150

Physical

Durability (mating cycles max) 10
 Gender Female
 Material - Metal Copper Alloy
 Material - Plating Mating Tin
 Material - Plating Termination Nickel
 Packaging Type Reel
 Termination Interface: Style Crimp or Compression
 Wire Insulation Diameter 2.80mm
 Wire Size AWG 22
 Wire Size mm² 0.35-0.50

Electrical

Current - Maximum per Contact 15A
 Voltage - Maximum 250V

Material Info

Reference - Drawing Numbers

Packaging Specification PK-31301-053

EU RoHS
ELV and RoHS
Compliant
REACH SVHC
 Not Reviewed
Halogen-Free
Status
Not Reviewed

China RoHS



Need more information on product environmental compliance?

Email productcompliance@molex.com
 For a multiple part number RoHS Certificate of Compliance, [click here](#)

Please visit the [Contact Us](#) section for any non-product compliance questions.

Search Parts in this Series

[502307Series](#)

Application Tooling | FAQ

Tooling specifications and manuals are found by selecting the products below. Crimp Height Specifications are then contained in the Application Tooling Specification document.

Global

Description	Product #
Extraction Tool for CTX150 Receptacle Crimp Terminal	0638134400
Hand Crimp Tool for CTX 1.50mm Receptacle Terminal, 0.30, 0.35, and 0.50mm ² Wires	0638193900
FineAdjust™ Applicator for CTX150 Receptacle Terminals, .30mm, .35mm, & .50mm	0639010400

PART NUMBERS		GRIP CODE	WIRE GAUGE			PLATING	DIM A ±0.2	DIM B ±0.3	DIM ØC ±0.1	DIM ØD ±0.1
D-WIND (LEFT PAYOFF)	B-WIND (RIGHT PAYOFF)		ISO mm2	JASO mm2	SAE gauge					
502307-0111	502307-0211	S	0.35-0.50	0.30-0.50	22	TIN (Sn)	2	2.6	1	1.54
502307-0112	502307-0212	M	0.75-1.00	0.85-1.25	20/18		2.6	3.2	1.5	1.98
502307-0113	502307-0213	L	1.50-2.00	1.25-2.00	16/14		3.1	3.9	1.8	2.44

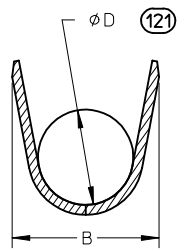

SECTION Y-Y
SCALE 8:1
INSULATION GRIP

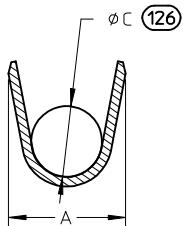

SECTION Z-Z
Scale 8:1

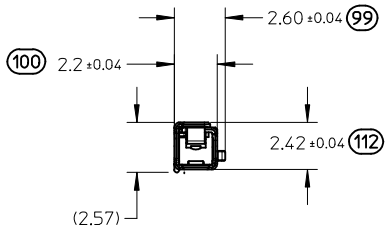

SECTION U-U
SCALE 10:1

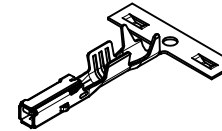
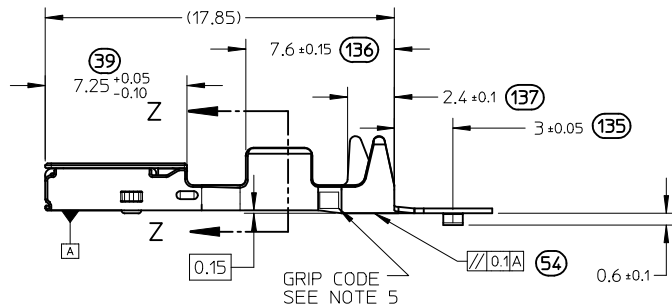
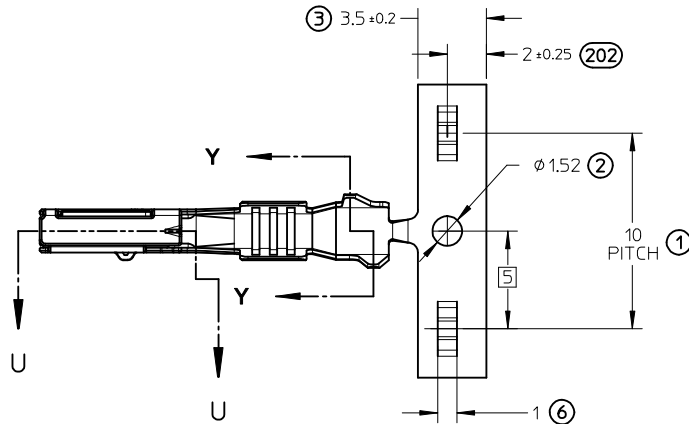
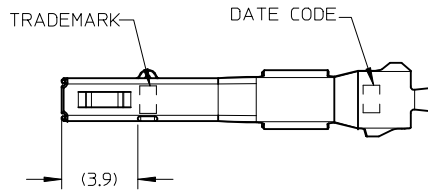
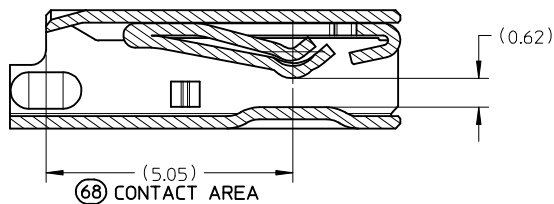

ISO VIEWS
NOT TO SCALE

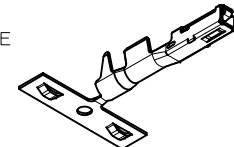

NOTES: (UNLESS OTHERWISE SPECIFIED)

- MATERIAL: COPPER ALLOY (Sn PREPLATED)
- PLATING MARK: TIN (Sn) - NO MARK
- PACKAGING PER PK-31301-053
- CRIMPING PER CS-502307-001
- PROBING DOWN THROAT OF TERMINAL NOT ALLOWED

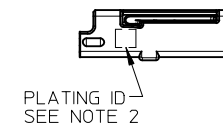

ENTER DESCRIPTION EC NO: UAU2010-0062 DRAWN BY: K.FERGUSON CHKD BY: D.NICHOLAS APPR: B.MOSER 2009/09/09 B	QUALITY SYMBOLS ▽=0 ▽=0	GENERAL TOLERANCES (UNLESS SPECIFIED)		DIMENSION STYLE MM ONLY		SCALE 1:1	DESIGN UNITS METRIC	THIRD ANGLE PROJECTION		
		mm	INCH	DRAWN BY	DATE	CTX150 FEMALE TERMINAL				
		4 PLACES ± ---	± ---	K.FERGUSON	10/25/2008					
		3 PLACES ± 0.08	± ---	CHECKED BY	DATE	MOLEX INCORPORATED				
2 PLACES ± 0.08	± ---	D.NICHOLAS	10/25/2008							
1 PLACE ± 0.08	± ---	APPROVED BY	DATE	MATERIAL NO. SEE TABLE DOCUMENT NO. SD-502307-001 SHEET NO. 1 OF 1						
ANGULAR ± 1°		B.MOSER	10/22/2008							