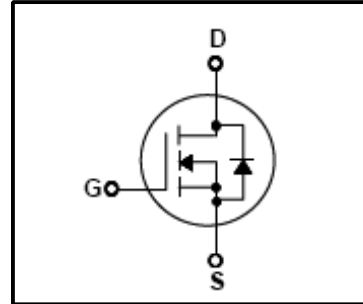
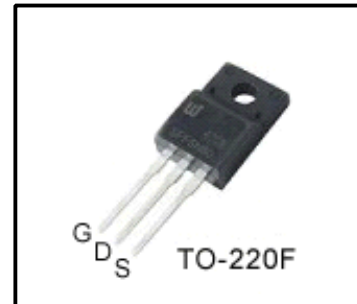


**Silicon N-Channel MOSFET**
**Features**

- 9A,500V,  $R_{DS(on)}$ (Max0.85Ω)@ $V_{GS}=10V$
- Ultra-low Gate charge(Typical 30nC)
- Fast Switching Capability
- 100%Avalanche Tested
- Maximum Junction Temperature Range(150℃)


**General Description**

This Power MOSFET is produced using Winsemi's advanced planar stripe,DMOS technology.This latest technology has been especially designed to minimize on-state resistance, have a high rugged avalanche characteristics .This devices is specially well suited for high efficiency switch model power supplies, power factor correction and half bridge and full bridge resonant topology line a electronic lamp ballast.


**Absolute Maximum Ratings**

Symbol	Parameter	Value	Units
$V_{DSS}$	Drain Source Voltage	500	V
$I_D$	Continuous Drain Current(@ $T_c=25^\circ C$ )	9	A
	Continuous Drain Current(@ $T_c=100^\circ C$ )	5.1	A
$I_{DM}$	Drain Current Pulsed (Note1)	32	A
$V_{GS}$	Gate to Source Voltage	±30	V
$E_{AS}$	Single Pulsed Avalanche Energy (Note2)	510	mJ
$E_{AR}$	Repetitive Avalanche Energy (Note1)	13	mJ
dv/dt	Peak Diode Recovery dv /dt (Note3)	3.5	V/ ns
$P_D$	Total Power Dissipation(@ $T_c=25^\circ C$ )	44	W
	Derating Factor above 25℃	0.35	W/℃
$T_J, T_{stg}$	Junction and Storage Temperature	-55~150	℃
$T_L$	Channel Temperature	300	℃

**Thermal Characteristics**

Symbol	Parameter	Value			Units
		Min	Typ	Max	
$R_{QJC}$	Thermal Resistance , Junction -to -Case	-	-	2.86	℃/W
$R_{QCS}$	Thermal Resistance , Case-to-Sink	-	0.5	-	℃/W
$R_{QJA}$	Thermal Resistance , Junction-to -Ambient	-	-	62.5	℃/W

**Electrical Characteristics(Tc=25 °C)**

Characteristics	Symbol	Test Condition	Min	Type	Max	Unit	
Gate leakage current	I <sub>GSS</sub>	V <sub>GS</sub> =±30V,V <sub>DS</sub> =0V	-	-	±100	nA	
Gate-source breakdown voltage	V <sub>(BR)GSS</sub>	I <sub>G</sub> =±10 μA,V <sub>DS</sub> =0V	±30	-	-	V	
Drain cut -off current	I <sub>DSS</sub>	V <sub>DS</sub> =500V,V <sub>GS</sub> =0V	-	-	1	μA	
		V <sub>DS</sub> =400V,TC=125 °C			10	μA	
Drain -source breakdown voltage	V <sub>(BR)DSS</sub>	I <sub>D</sub> =250 μA,V <sub>GS</sub> =0V	500	-	-	V	
Breakdown voltage Temperature Coefficient	ΔBV <sub>DSS</sub> /ΔT <sub>J</sub>	I <sub>D</sub> =250μA,Referenced to 25 °C		0.57		V/°C	
Gate threshold voltage	V <sub>GS(th)</sub>	V <sub>DS</sub> =10V,I <sub>D</sub> =250 μA	2	-	4	V	
Drain -source ON resistance	R <sub>DS(ON)</sub>	V <sub>GS</sub> =10V,I <sub>D</sub> =4.8A	-	-	0.85	Ω	
Forward Transconductance	g <sub>fs</sub>	V <sub>DS</sub> =50V,I <sub>D</sub> =4.8A	3.7			S	
Input capacitance	C <sub>iss</sub>	V <sub>DS</sub> =25V,	-	1018	-	pF	
Reverse transfer capacitance	C <sub>rss</sub>	V <sub>GS</sub> =0V,	-	155	-		
Output capacitance	C <sub>oss</sub>	f=1MHz	-	8	-		
Switching time	Rise time	tr	V <sub>DD</sub> =250V,	-	11	-	ns
	Turn-on time	ton	I <sub>D</sub> =9A	-	23	-	
	Fall time	tf	R <sub>G</sub> =9.1Ω	-	26	-	
	Turn-off time	toff	R <sub>D</sub> =31Ω (Note4,5)	-	19	-	
Total gate charge(gate-source plus gate-drain)	Q <sub>g</sub>	V <sub>DD</sub> =400V, V <sub>GS</sub> =10V,	-	30	38	nC	
Gate-source charge	Q <sub>gs</sub>	I <sub>D</sub> =9A	-	7	9		
Gate-drain("miller") Charge	Q <sub>gd</sub>	(Note4,5)	-	15	18		

**Source-Drain Ratings and Characteristics(Ta=25 °C)**

Characteristics	Symbol	Test Condition	Min	Type	Max	Unit
Continuous drain reverse current	I <sub>DR</sub>	-	-	-	9	A
Pulse drain reverse current	I <sub>DRP</sub>	-	-	-	32	A
Forward voltage(diode)	V <sub>DSF</sub>	I <sub>DR</sub> =9A,V <sub>GS</sub> =0V	-	1.4	2.0	V
Reverse recovery time	trr	I <sub>DR</sub> =9A,V <sub>GS</sub> =0V,	-	442	633	ns
Reverse recovery charge	Q <sub>rr</sub>	dI <sub>DR</sub> / dt =100 A / μs	-	2.16	3.24	μC

Note 1.Repeativity rating :pulse width limited by junction temperature

2.L=18.5mH I<sub>AS</sub>=9A,V<sub>DD</sub>=50V,R<sub>G</sub>=0Ω,Starting T<sub>J</sub>=25 °C

3.I<sub>SD</sub>≤9A,di/dt≤300A/μs,V<sub>DD</sub><BV<sub>DSS</sub>,STARTING T<sub>J</sub>=25 °C

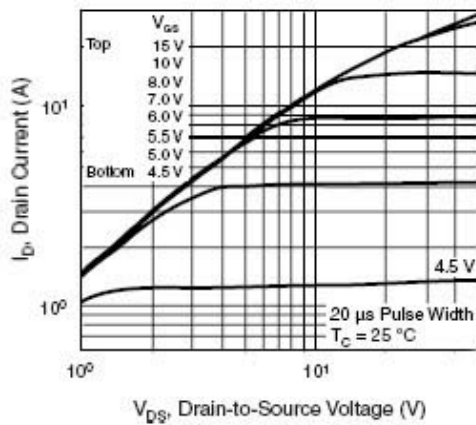
4.Pulse Test:Pulse Width≤300us,Duty Cycle≤2%

5. Essentially independent of operating temperature.

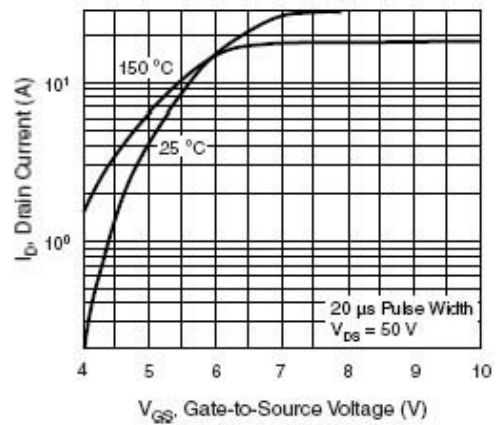
This transistor is an electrostatic sensitive device

Please handle with caution

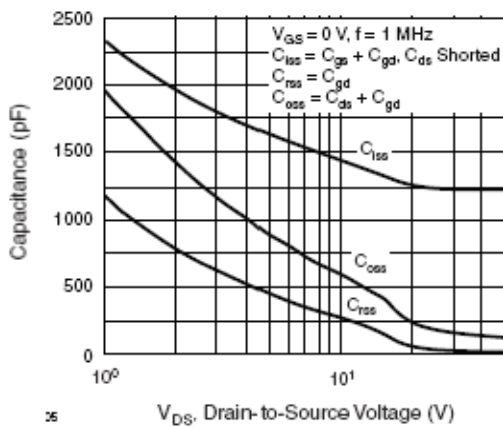




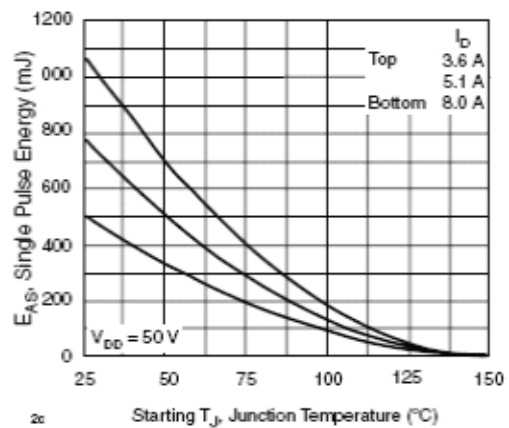
**Fig.1 On State Characteristics**



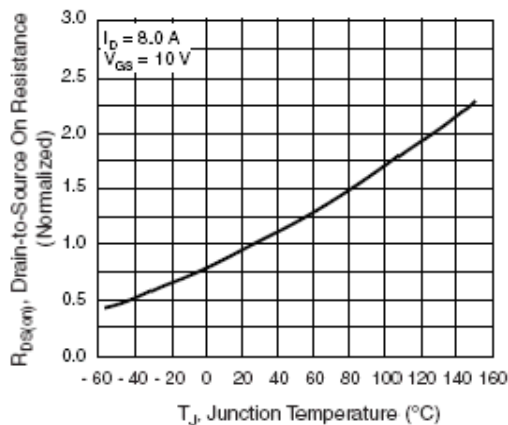
**Fig.2 Transfer Characteristics**



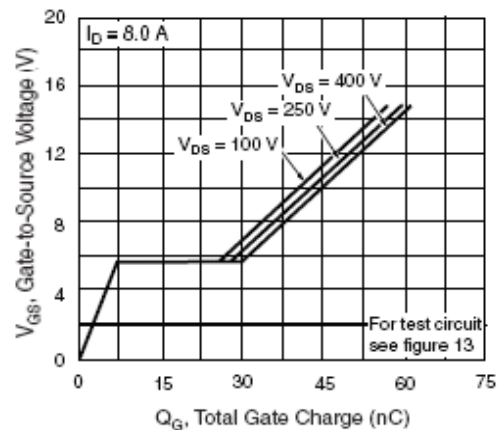
**Fig.3 Capacitance Variation vs Drain Voltage**



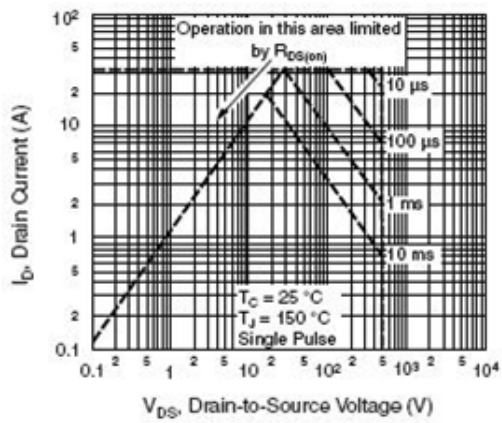
**Fig.4 Maximum Avalanche Energy vs On-State Current**



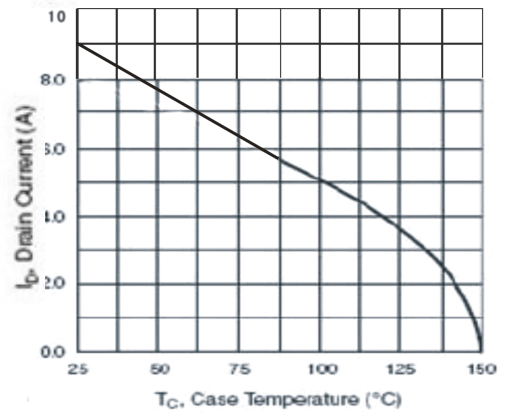
**Fig.5 On-Resistance Variation vs Junction temperature**



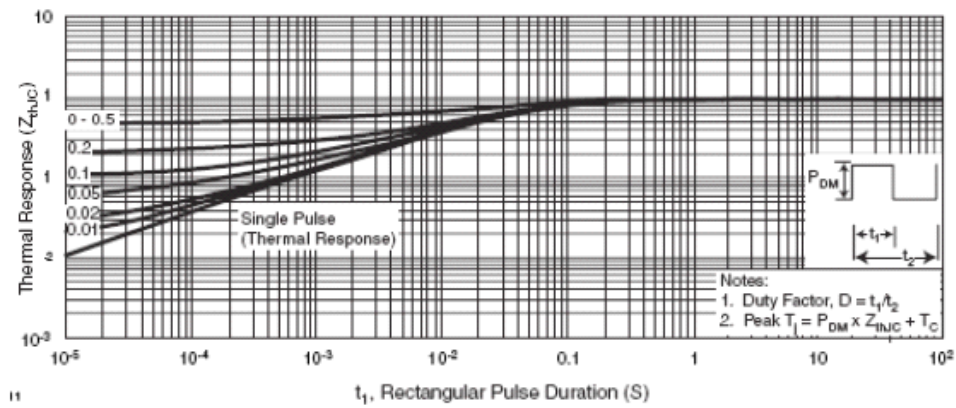
**Fig.6 Gate Charge Characteristics**



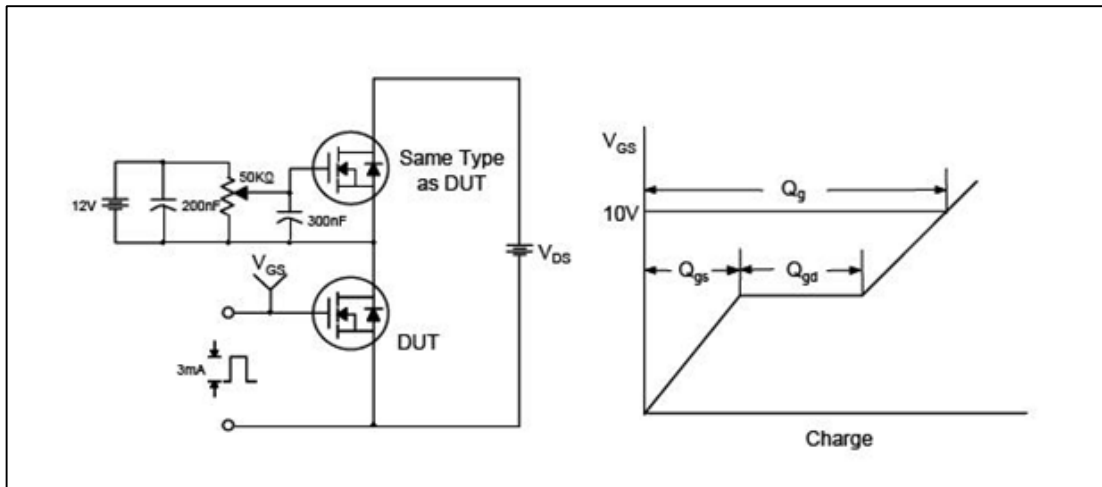
**Fig.7 Maximum Safe Operation Area**



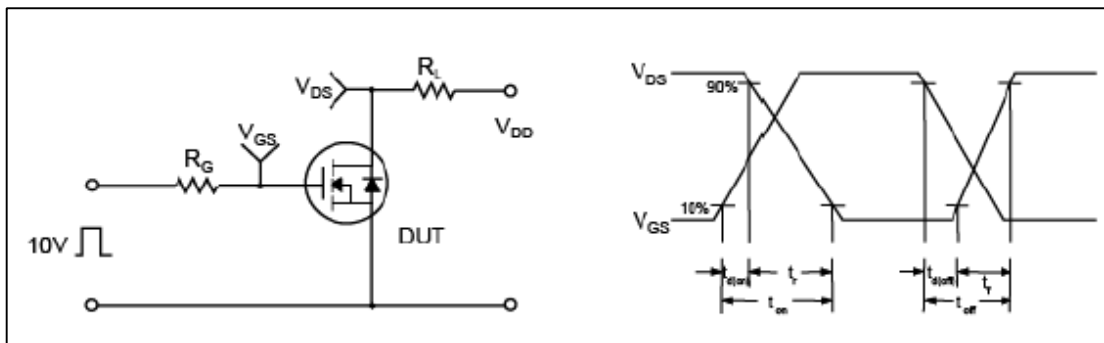
**Fig.8 Maximum Drain Current vs Case temperature**



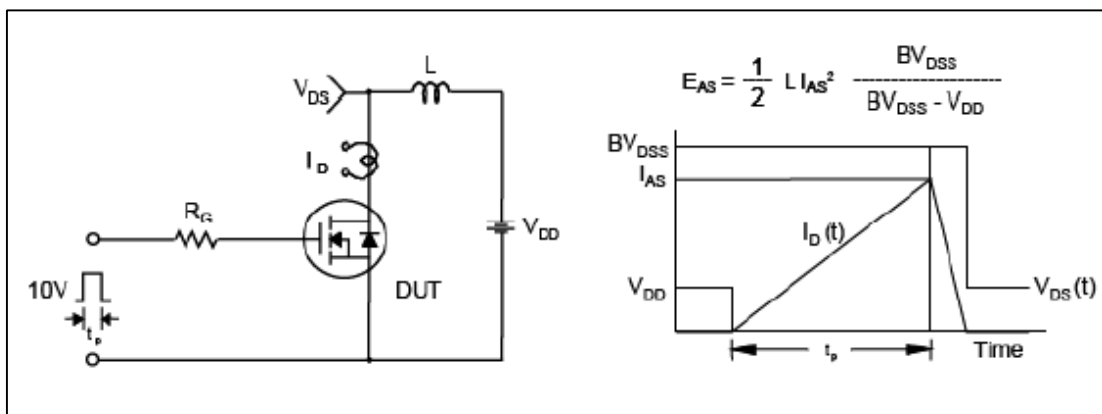
**Fig.9 Transient thermal Response Curve**



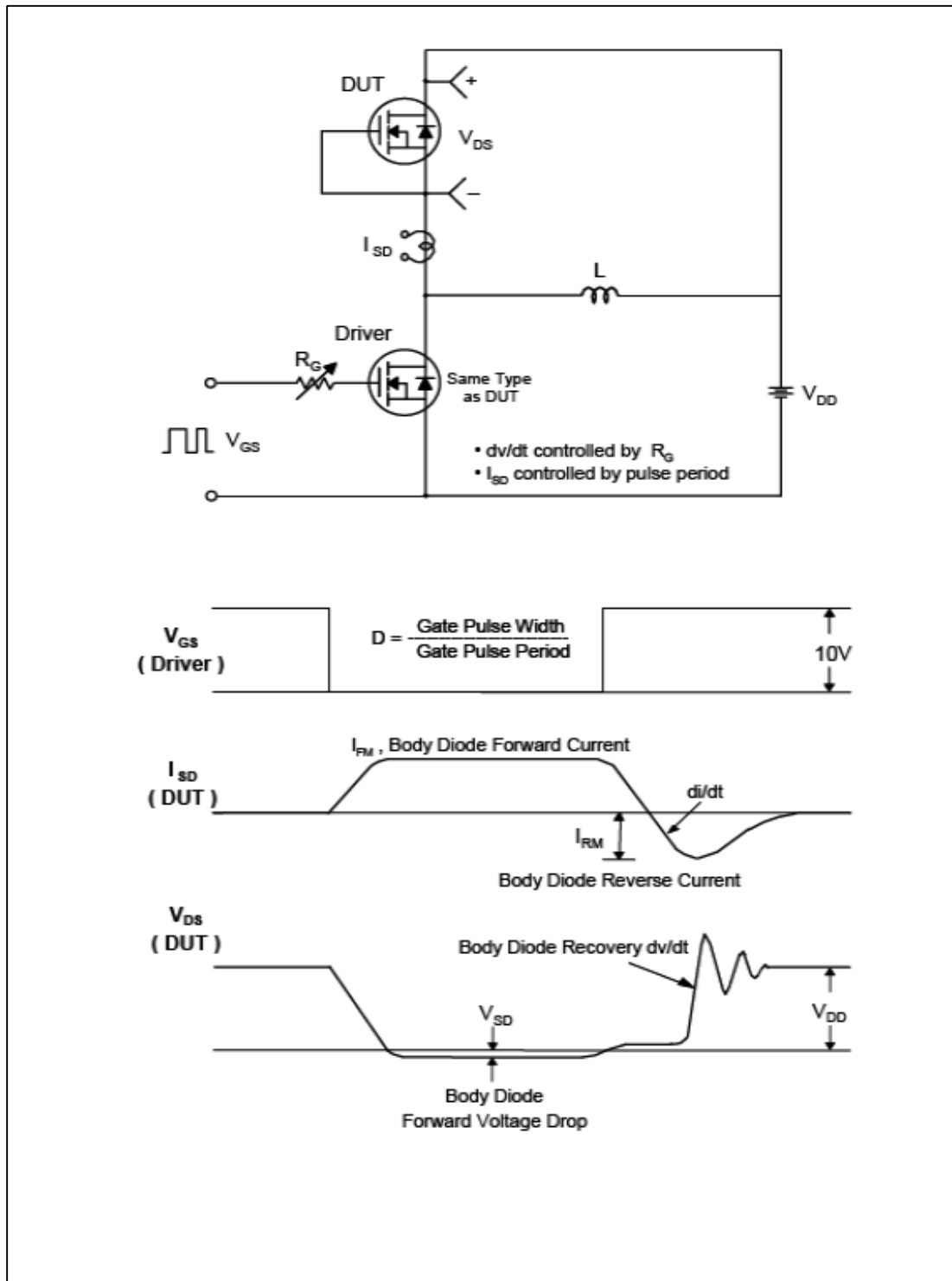
**Fig.10 Gate Test circuit & Waveform**



**Fig.11 Resistive Switching Test Circuit & Waveform**



**Fig.12 Unclamped Inductive Switching Test Circuit & Waveform**



**Fig.13 Peak Diode Recovery  $dv/dt$  Test Circuit & Waveform**

