

STRUCTURE Silicon Monolithic Integrated Circuit
 TYPE 1ch Series Regulator Driver IC
 PRODUCT SERIES **BD35269HFN**
 FEATURES •High Accuracy Voltage Regulator (1.200V±1%)
 •Non Rush Current on Start up (NRCS)
 •UVLO · SCP Function
 •Maximum Output Current : 1.0A

○Absolute Maximum Ratings (Ta=25°C)

PARAMETER	SYMBOL	RATING	UNIT
Input Voltage 1	V _{CC}	+6.0 * ¹	V
Input Voltage 2	V _{IN}	+6.0 * ¹	V
Enable Input Voltage	V _{EN}	-0.3~+6.0	V
Output Current	I _O	1.0* ¹	A
Power Dissipation 1	Pd1	0.63 * ²	W
Power Dissipation 2	Pd2	1.35 * ³	W
Power Dissipation 3	Pd3	1.75 * ⁴	W
Operating Temperature Range	Topr	-10~+100	°C
Storage Temperature Range	Tstg	-55~+150	°C
Maximum Junction Temperature	Tjmax	+150	°C

*1 Should not exceed Pd.

*2 Reduced by 5.04mW/°C for each increase in Ta≥25°C (when mounted on a 70mm×70mm×1.6mm glass-epoxy board, 1-layer)

*3 Reduced by 10.8mW/°C for each increase in Ta≥25°C (when mounted on a 70mm×70mm×1.6mm glass-epoxy board, 1-layer)
 copper foil area : 15mm × 15mm

*4 Reduced by 14.0mW/°C for each increase in Ta≥25°C (when mounted on a 70mm×70mm×1.6mm glass-epoxy board, 1-layer)
 copper foil area : 70mm × 70mm

○Operating Conditions (Ta=25°C)

PARAMETER	SYMBOL	MIN.	MAX.	UNIT
Input Voltage 1	V _{CC}	4.3	5.5	V
Input Voltage 2	V _{IN}	1.5	V _{CC} -1 * ¹ * ⁵	V
Enable Input Voltage	V _{EN}	0	5.5	V

*5 V_{CC} and V_{IN} do not have to be implemented in the order listed.

★This product is not designed for use in radioactive environments.

Status of this document

The Japanese version of this document is the official specification.

This translated version is intended only as a reference, to aid in understanding the official version.

If there are any differences between the original and translated versions of this document, the official Japanese language version takes priority.

ELECTRICAL CHARACTERISTICS (Unless otherwise specified, Ta=25°C, VCC=5V, VEN=3V, VIN=1.7V)

Parameter	Symbol	Limit			Unit	Condition
		Min.	Typ.	Max.		
Bias Current	ICC	-	0.7	1.2	mA	
VCC Shutdown Mode Current	IST	-	0	10	μA	VEN=0V
Maximum Output Current	IO	1.0	-	-	A	
Feedback Voltage 1	VOS1	1.188	1.200	1.212	V	
Feedback Voltage 2	VOS2	1.176	1.200	1.224	V	Tj=-10 to 100°C
Line Regulation 1	Reg.l1	-	0.1	0.5	%/V	VCC=4.3V to 5.5V
Line Regulation 2	Reg.l2	-	0.1	0.5	%/V	VIN=1.5V to 3.3V
Load Regulation	Reg.L	-	0.5	10	mV	IO=0 to 1A
Output ON Resistance	RON	-	170	400	mΩ	IO=1A, VIN=1.2V, Tj=-10 to 100°C
Standby Discharge Current	IDEN	1	-	-	mA	VEN=0V, VO=1V
[ENABLE]						
Enable Pin Input Voltage High	ENHIGH	2	-	-	V	
Enable Pin Input Voltage Low	ENLOW	0	-	0.8	V	
Enable Input Bias Current	IEN	-	7	10	μA	VEN=3V
[NRCS]						
NRCS Charge Current	INRCS	12	20	28	μA	
NRCS Standby Voltage	VSTB	-	0	50	mV	VEN=0V
[UVLO]						
VCC Undervoltage Lockout Threshold Voltage	VCCUVLO	3.5	3.8	4.1	V	VCC:Sweep-up
VCC Undervoltage Lockout Hysteresis Voltage	VCCHYS	100	160	220	mV	VCC:Sweep-down
VIN Undervoltage Lockout Threshold Voltage	VINUVLO	0.72	0.84	0.96	V	VIN:Sweep-up
[SCP]						
SCP Start up Voltage	VOSCP	VO×0.3	VO×0.4	VO×0.5	V	
SCP Delay time	TSCP	45	90	200	μsec	

OPHYSICAL DIMENSIONS

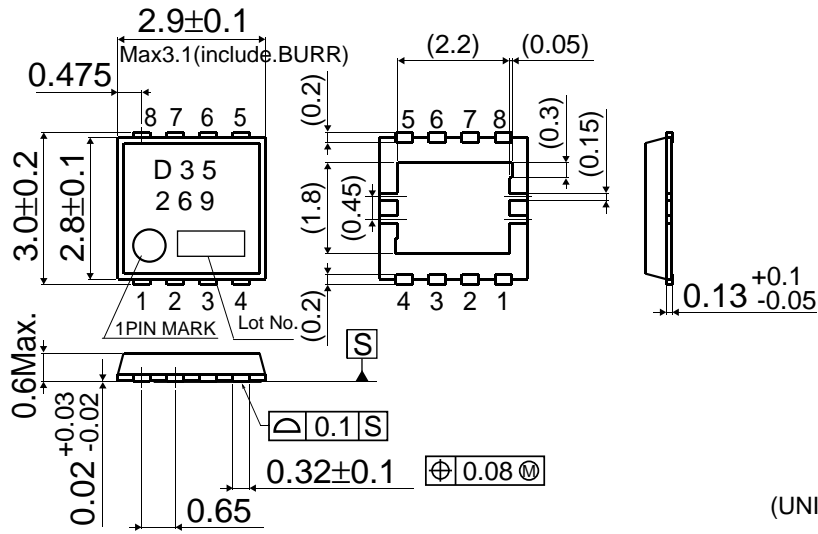

(UNIT : mm)
HSON8

OBLOCK DIAGRAM

OPin number, Pin name

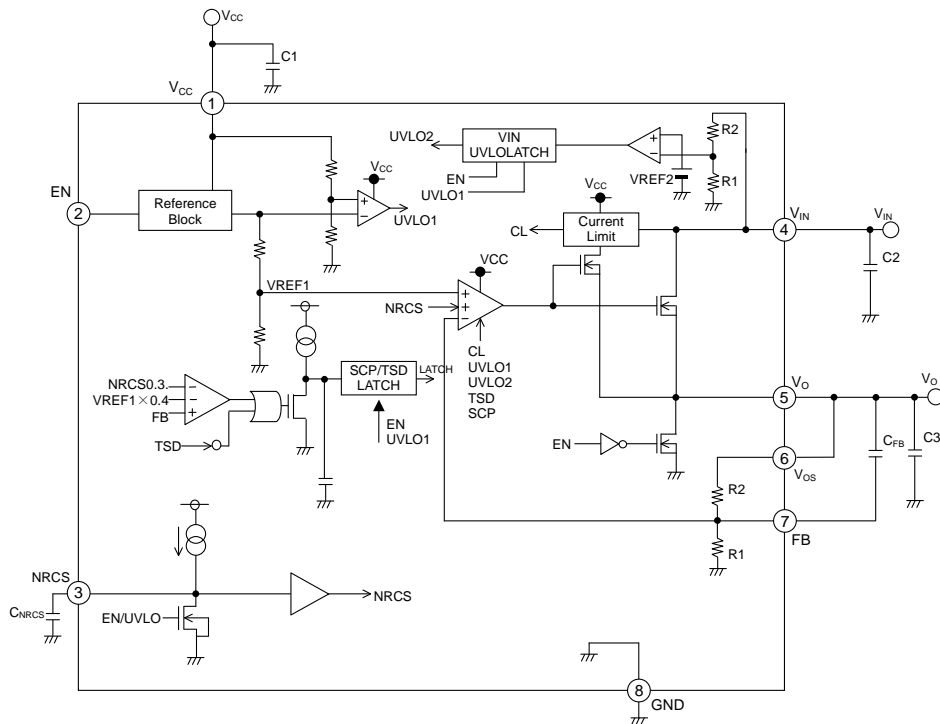

PIN No.	Pin name
1	V _{CC}
2	EN
3	NRCS
4	V _{IN}
5	V _O
6	V _{OS}
7	FB
-	FIN

ONOTES FOR USE

- (1) Absolute maximum range
Although the quality of this product is rigorously controlled, and circuit operation is guaranteed within the operation ambient temperature range, the device may be destroyed when applied voltage or operating temperature exceeds its absolute maximum rating. Because the failure mode (such as short mode or open mode) cannot be identified in this instance, it is important to take physical safety measures such as fusing if a specific mode in excess of absolute rating limits is considered for implementation.
- (2) Ground potential
Make sure the potential for the GND pin is always kept lower than the potentials of all other pins, regardless of the operating mode, including transient conditions.
- (3) Thermal Design
Provide sufficient margin in the thermal design to account for the allowable power dissipation (Pd) expected in actual use.
- (4) Using in the strong electromagnetic field
Use in strong electromagnetic fields may cause malfunctions.
- (5) ASO
Be sure that the output transistor for this IC does not exceed the absolute maximum ratings or ASO value.
- (6) Thermal shutdown circuit
The IC is provided with a built-in thermal shutdown (TSD) circuit. When chip temperature reaches the threshold temperature shown below, output goes to a cut-off state. (This IC latches output to off mode when the temperature recedes to the specified level. To release latch mode, EN or Vcc is re-operated.) Note that the TSD circuit is designed exclusively to shut down the IC in abnormal thermal conditions. It is not intended to protect the IC or guarantee performance when extreme heat occurs. Therefore, the TSD circuit should not be employed with the expectation of continued use or subsequent operation once TSD is operated.

TSD ON temperature [°C] (typ.)
175

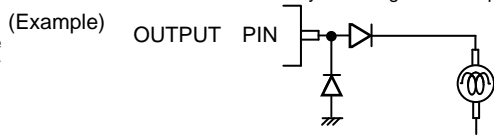
- (7) GND pattern
When both a small-signal GND and high current GND are present, single-point grounding (at the set standard point) is recommended, in order to separate the small-signal and high current patterns, and to be sure the voltage change stemming from the wiring resistance and high current does not cause any voltage change in the small-signal GND. In the same way, care must be taken to avoid wiring pattern fluctuations in any connected external component GND.
- (8) Output Capacitor (C3)
Mount an output capacitor between Vo and GND for stability purposes. The output capacitor is for the open loop gain phase compensation and reduces the output voltage load regulation. If the capacitor value is not large enough, the output voltage may oscillate. And if the equivalent series resistance (ESR) is too large, the output voltage rise/drop increases during a sudden load change. A Low ESR22uF capacitor is recommended. However, the stability depends on the characteristics of temperature and load. And if several kinds of capacitors are utilized in parallel, the output voltage may oscillate due to lack of phase margin. Please confirm operation across a variety of temperature and load conditions.
- (9) Input Capacitor (C1, C2)
The input capacitor reduces the output impedance of the voltage supply source connected in the Vcc and Vin. If the output impedance of this power supply increases, the input voltage (Vcc, Vin) may become unstable. This may result in the output voltage oscillation or lowering ripple rejection. Stability depends on power supply characteristics and the substrate wiring pattern. Please confirm operation across a variety of temperature and load conditions.
- (10) NRCS (Non Rush Current on Start-up) Setting (CNRCS)
The NRCS function is built in this IC to prevent rush current from going through the load (Vin to Vo) for start-up. The constant current comes from the NRCS pin when EN is high or UVLO function is deactivated. Temporary reference voltage is made proportional to time due to current charge the NRCS pin capacitor and make output voltage start up proportional to this reference voltage. To obtain a stable NRCS delay time, a 0.001 μF ~ 1 μF capacitor (X5R or X7R) with susceptibility to temperature is recommended.
- (11) SCP (Short Circuit Protection)
Timer latch short circuit protection function is built in the IC. (NRCS is also working at the same time.) to protect the break down of the power MOSFET caused by rush current when the output is shorted to GND. This function becomes active and latches the status when the output voltage level goes under by 40% of specified Vo. In this case, start Vcc or EN up again to deactivate this latch function.
- (12) Input Terminal (Vcc, Vin)
The EN, Vin, and Vcc are isolated. The UVLO protects incorrect operation when the voltage level of Vin and Vcc are low. The output becomes high when these pins reach the individual threshold level independent of the start-up pin order. However, if Vin shut down while the IC works under the normal operation, SCP function becomes active and latches the status. And the output does not come back active even though Vin goes up high again. In this case, start Vcc up again to deactivate this latch function.
- (13) Heat sink (FIN)
Since the heat sink (FIN) is connected with the Sub, short it to the GND. It is possible to minimize the thermal resistance by soldering it to GND plane of PCB.
- (14) Please add a protection diode when a large inductance component is connected to the output terminal, and reverse-polarity power is possible at startup or in output OFF condition.
(Example) 
- (15) Short-circuits between pins and and mounting errors
Do not short-circuit between output pin (Vo) and supply pin (Vcc) or ground (GND), or between supply pin (Vcc) and ground (GND). Mounting errors, such as incorrect positioning or orientation, may destroy the device.
Mounting errors, such as incorrect positioning or orientation, may destroy the device.
- (16) Each block of this IC contains logic circuits which can pull an instantaneous amount of rush current when switching. Therefore, special consideration should be given to the power supply coupling capacitance and the width of power supply and ground traces. Avoid excessively long or convoluted trace patterns.

Notes

No copying or reproduction of this document, in part or in whole, is permitted without the consent of ROHM CO.,LTD.

The content specified herein is subject to change for improvement without notice.

The content specified herein is for the purpose of introducing ROHM's products (hereinafter "Products"). If you wish to use any such Product, please be sure to refer to the specifications, which can be obtained from ROHM upon request.

Examples of application circuits, circuit constants and any other information contained herein illustrate the standard usage and operations of the Products. The peripheral conditions must be taken into account when designing circuits for mass production.

Great care was taken in ensuring the accuracy of the information specified in this document. However, should you incur any damage arising from any inaccuracy or misprint of such information, ROHM shall bear no responsibility for such damage.

The technical information specified herein is intended only to show the typical functions of and examples of application circuits for the Products. ROHM does not grant you, explicitly or implicitly, any license to use or exercise intellectual property or other rights held by ROHM and other parties. ROHM shall bear no responsibility whatsoever for any dispute arising from the use of such technical information.

The Products specified in this document are intended to be used with general-use electronic equipment or devices (such as audio visual equipment, office-automation equipment, communication devices, electronic appliances and amusement devices).

The Products are not designed to be radiation tolerant.

While ROHM always makes efforts to enhance the quality and reliability of its Products, a Product may fail or malfunction for a variety of reasons.

Please be sure to implement in your equipment using the Products safety measures to guard against the possibility of physical injury, fire or any other damage caused in the event of the failure of any Product, such as derating, redundancy, fire control and fail-safe designs. ROHM shall bear no responsibility whatsoever for your use of any Product outside of the prescribed scope or not in accordance with the instruction manual.

The Products are not designed or manufactured to be used with any equipment, device or system which requires an extremely high level of reliability the failure or malfunction of which may result in a direct threat to human life or create a risk of human injury (such as a medical instrument, transportation equipment, aerospace machinery, nuclear-reactor controller, fuel-controller or other safety device). ROHM shall bear no responsibility in any way for use of any of the Products for the above special purposes. If a Product is intended to be used for any such special purpose, please contact a ROHM sales representative before purchasing.

If you intend to export or ship overseas any Product or technology specified herein that may be controlled under the Foreign Exchange and the Foreign Trade Law, you will be required to obtain a license or permit under the Law.

Thank you for your accessing to ROHM product informations.

More detail product informations and catalogs are available, please contact your nearest sales office.

ROHM Customer Support System

THE AMERICAS / EUROPE / ASIA / JAPAN

www.rohm.com

Contact us : webmaster@rohm.co.jp