



W83783S
Winbond H/W
Monitoring IC



W83783S Data Sheet Revision History

	PAGES	DATES	VERSION	VERSION ON WEB	MAIN CONTENTS
1	n.a.			n.a.	All the versions before 0.50 are for internal use.
2	n.a.	98/7	0.5	n.a.	First publication.
3	P.36	99/4	0.55	A1	Add the content of Diode Selection Register Index 59h(Bank0)
4	P.38	99/4	0.55	A1	Add the content of 7.25 Fan Divisor Register and rename to VBAT Monitor Control Register Index 5Dh(Bank0)
5	n.a.	05/4	1.0	1.0	Change version and version on website to 1.0
6					
7					
8					
9					
10					

Please note that all data and specifications are subject to change without notice. All the trade marks of products and companies mentioned in this data sheet belong to their respective owners.



Table of Contents-

1.	GENERAL DESCRIPTION	1
2.	FEATURES	2
2.1	Monitoring Items	2
2.2	Actions Enabling	2
2.3	General	2
2.4	Package	2
3.	KEY SPECIFICATIONS	3
4.	PIN CONFIGURATION	3
5.	PIN DESCRIPTION.....	4
6.	FUNCTIONAL DESCRIPTION	6
6.1	General Description	6
6.2	Access Interface	6
6.2.1	The first serial bus access timing is shown as follow:	6
6.2.2	The serial bus timing of the temperature 2 and 3 is shown as follow:	7
6.3	Analog Inputs	10
6.3.1	Monitor over 4.096V voltage:.....	11
6.3.2	Monitor negative voltage:.....	12
6.3.3	Monitor temperature from thermistor:	13
6.3.4	Monitor temperature from Pentium II™ thermal diode or bipolar transistor 2N3904	13
6.4	FAN Speed Count and FAN Speed Control	14
6.4.1	Fan speed count.....	14
6.4.2	Fan speed control.....	15
6.5	Temperature Measurement Machine	16
6.5.1	W83783S temperature sensor 2 SMI# interrupt has two modes:	17
6.5.2	W83783S temperature sensor 1 SMI# interrupt has three modes.....	18
6.5.3	W83783S temperature sensor 1 Over-Temperature (OVT#) has three modes	19
6.6	Voltage and Fan SMI# mode	20
6.6.1	Voltage SMI# mode	20
6.6.2	Fan SMI# mode.....	20
7.	REGISTERS AND RAM.....	21
7.1	Configuration Register — Index 40h	21
7.2	Interrupt Status Register 1 — Index 41h	23
7.3	Interrupt Status Register 2 — Index 42h	23
7.4	SMI# Mask Register 1 — Index 43h.....	24
7.5	SMI# Mask Register 2 — Index 44h.....	25
7.6	Reserved Register — Index 45h-- 46h	25
7.7	VID/Fan Divisor Register — Index 47h.....	26
7.8	Serial Bus Address Register — Index 48h	26
7.9	Value RAM — Index 20h- 3Fh or 60h - 7Fh.....	27



7.10	Voltage ID (VID4) & Device ID — Index 49h	29
7.11	Temperature 2 and Temperature 3 Serial Bus Address Register — Index 4Ah	29
7.12	Pin Control Register — Index 4Bh.....	30
7.13	IRQ#/OVT# Property Select — Index 4Ch	31
7.14	FAN IN/OUT and BEEP/GPO# Control Register — Index 4Dh	32
7.15	Register 50h ~ 5Fh Bank Select — Index 4Eh.....	33
7.16	Winbond Vendor ID — Index 4Fh.....	33
7.17	Winbond Test Register — Index 50h - 55h (Bank 0).....	34
7.18	BEEP Control Register 1 — Index 56h (Bank 0).....	34
7.19	BEEP Control Register 2 — Index 57h (Bank 0).....	35
7.20	Chip ID — Index 58h (Bank 0).....	36
7.21	Diode Selection Register — Index 59h (Bank 0).....	36
7.22	PWMOUT1 Control Register — Index 5Ah (Bank 0).....	37
7.23	PWMOUT2 Control Register — Index 5Bh (Bank 0).....	37
7.24	PWMOUT1/2 Clock Select Register — Index 5Ch (Bank 0).....	38
7.25	VBAT Monitor Control Register — Index 5Dh (Bank 0)	39
7.26	Reserved Register — Index 5Eh (Bank 0)	40
7.27	Reserved Register — Index 5Fh (Bank 0)	40
7.28	Temperature Sensor 1 Temperature (High Byte) Register — Index 00h.....	40
7.29	Temperature Sensor 1 Temperature (Low Byte) Register — Index 00h	40
7.30	Temperature Sensor 1 Configuration Register — Index 01h	41
7.31	Temperature Sensor 1 Hysteresis (High Byte) Register — Index 02h.....	42
7.32	Temperature Sensor 1 Hysteresis (Low Byte) Register — Index 02h	42
7.33	Temperature Sensor 1 Over-temperature (High Byte) Register — Index 03h.....	43
7.34	Temperature Sensor 1 Over-temperature (Low Byte) Register — Index 03h.....	43
7.35	Reserved Register — Index 50h--52h (BANK4).....	44
7.36	BEEP Control Register 3 — Index 53h (Bank 4).....	44
7.37	Reserved Register — Index 54h--58h (Bank 4)	44
7.38	Real Time Hardware Status Register I — Index 59h (Bank 4).....	44
7.39	Real Time Hardware Status Register II — Index 5Ah (Bank 4)	45
8.	SPECIFICATIONS	47
8.1	Absolute Maximum Ratings	47
8.2	DC Characteristics.....	47
8.3	AC Characteristics	49
	8.3.1 Serial Bus Timing Diagram	49
9.	HOW TO READ THE TOP MARKING	50
10.	PACKAGE DIMENSIONS.....	51
11.	APPLICATION CIRCUIT OF WINBOND W83783S	52



1. GENERAL DESCRIPTION

W83783S is an evolving version of W83782D --- Winbond's most popular hardware status monitoring IC. W83783S can be used to monitor several critical hardware parameters of the system, including power supply voltages, fan speeds, and temperatures, which are very important for a high-end computer system to work stable and properly. W83783S provides I2C™ serial bus interface.

An 8-bit analog-to-digital converter (ADC) was built inside W83783S. W83783S can monitor 6 analog voltage inputs, 3 fan tachometer inputs, and 3 remote temperatures. The remote temperature sensing can be performed by thermistors, or 2N3904 NPN-type transistors, or directly from Intel™ Deschutes CPU thermal diode output. Also W83783S provides: 2 PWM (pulse width modulation) outputs for the fan speed control; beep tone output for warning; SMI#, OVT#, GPO# signals for system protection events.

Through the application software or BIOS, the users can read all the monitored parameters of system from time to time. And a pop-up warning can be also activated when the monitored item is out of the proper/preset range. The application software could be Winbond's Hardware Doctor™, or Intel™ LDCM (LanDesk Client Management), or other management application software. Also the users can set up the upper and lower limits (alarm thresholds) of these monitored parameters and to activate one programmable and maskable interrupts. An optional beep tone could be used as warning signal when the monitored parameter is out of the preset range.

Additionally, 5 VID inputs are provided to read the VID of CPU (i.e. Pentium™ II) if applicable. This is to provide the Vcore voltage correction automatically. Also W83783S uniquely provides an optional feature: early stage (before BIOS was loaded) beep warning. This is to detect if the fatal elements present --- Vcore or +3.3V voltage fail, and the system can not be boomed up.



2. FEATURES

2.1 Monitoring Items

- 3 thermal inputs from remote thermistors or 2N3904 NPN-type transistors or Pentium™ II (Deschutes) thermal diode output
- 6 voltage inputs
- --- typical for Vcore, +3.3V, +12V, -12V, +5V, -5V
- 3 fan speed monitoring inputs
- Case open detection input
- WATCHDOG comparison of all monitored values
- Programmable hysteresis and setting points (alarm thresholds) for all monitored items

2.2 Actions Enabling

- Beep tone warning
- 2 PWM (pulse width modulation) outputs for fan speed control (MUX optional)
- --- Total up to 2 sets of fan speed monitoring and controlling
- Issue SMI#, OVT#, GPO# signals to activate system protection
- Warning signal pop-up in application software

2.3 General

- I²C™ serial bus interface
- 5 VID input pins for CUP Vcore identification (for Pentium™ II)
- Initial power fault beep (for +3.3V, Vcore)
- Intel™ LDCM (DMI driver 2.0) support
- Acer™ ADM (DMI driver 2.0) support
- Winbond hardware monitoring application software (Hardware Doctor™) support, for both Windows 95/98 and Windows NT 4.0/5.0
- Input clock rate optional for 24, 48, 14.318 Mhz
- 5V Vcc operation

2.4 Package

- 24-pin SOP



3. KEY SPECIFICATIONS

- Voltage monitoring accuracy ±1% (Max)
- Monitoring Temperature Range and Accuracy
- 40°C to +120°C ± 3°C (Max)
- Supply Voltage 5V
- Operating Supply Current 5 mA typ.
- ADC Resolution 8 Bits

4. PIN CONFIGURATION

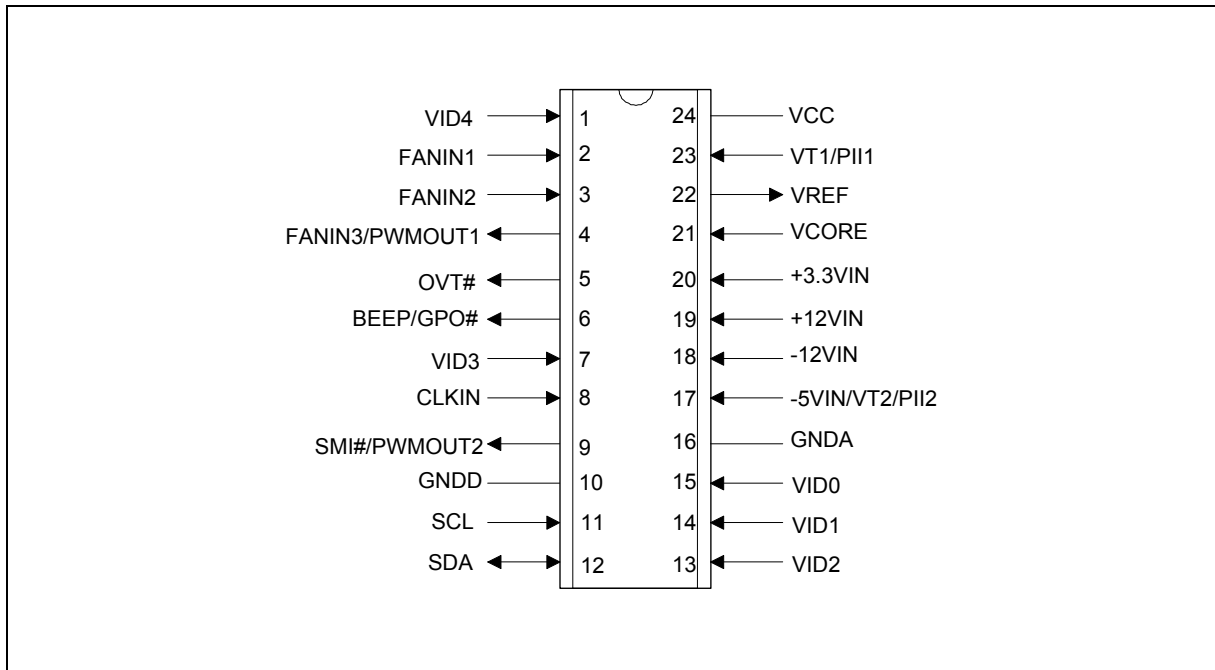



5. PIN DESCRIPTION

I/O _{12t}	- TTL level bi-directional pin with 12 mA source-sink capability
I/O _{12ts}	- TTL level and schmitt trigger
OUT ₁₂	- Output pin with 12 mA source-sink capability
AOUT	- Output pin(Analog)
OD ₁₂	- Open-drain output pin with 12 mA sink capability
IN _t	- TTL level input pin
IN _{ts}	- TTL level input pin and schmitt trigger
AIN	- Input pin(Analog)

PIN NAME	PIN NO.	TYPE	DESCRIPTION
VID4	1	IN _t	Voltage Supply readouts from Pentium II™.
FANIN1	2	IN _{ts}	0V to 5V amplitude fan tachometer input.
FANIN2	3	IN _{ts}	0V to 5V amplitude fan tachometer input.
FANIN3/ PWMOUT1	4	IN _{ts} / OUT _{12t}	0V to 5V amplitude fan tachometer input. / Fan speed control (PWM) output. This multi-functional pin is programmable.
OVT#	5	OD ₁₂	Over temperature Shutdown Output.
BEEP/GPO#	6	OD ₁₂	Beep (Default) / General purpose output This multi-functional pin is programmable.
VID3	7	IN _t	Voltage Supply readouts from Pentium II™.
CLKIN	8	IN _t	System clock input. Can select 48MHz or 24MHz or 14.318MHz. The default is 24MHz.
SMI# / PWMOUT2	9	OD ₁₂ / OUT _{12t}	System Management Interrupt (open drain). The default state is disabled. Fan speed control (PWM) output. This multi-functional pin is programmable.
GNDD	10	DGROUND	Internally connected to all digital circuitry.
SCL	11	IN _{ts}	Serial Bus Clock.
SDA	12	OD ₁₂	Serial Bus bi-directional Data.
VID2	13	IN _t	Voltage Supply readouts from Pentium II™.



Pin description, continued

PIN NAME	PIN NO.	TYPE	DESCRIPTION
VID1	14	IN _t	Voltage Supply readouts from Pentium II™.
VID0	15	IN _t	Voltage Supply readouts from Pentium II™.
GNDA	16	AGROUND	Internally connected to all analog circuitry. The ground reference for all analog inputs.
-5VIN / VT2 / PII2	17	AIN	0V to 4.096V FSR Analog Inputs (Default). / Thermistor 2 terminal input. / Pentium II™ thermal 2 diode input. This multi-functional pin is programmable.
-12VIN	18	AIN	0V to 4.096V FSR Analog Inputs.
+12VIN	19	AIN	0V to 4.096V FSR Analog Inputs.
+3.3VIN	20	AIN	0V to 4.096V FSR Analog Inputs.
VCOREA	21	AIN	0V to 4.096V FSR Analog Inputs.
VREF	22	AOUT	Reference Voltage.
VT1 / PII1	23	AIN	Thermistor 1 terminal input. / Pentium II™ thermal diode 1 input.
V _{CC} (+5V)	24	POWER	+5V V _{CC} power. Bypass with the parallel combination of 10μF (electrolytic or tantalum) and 0.1μF (ceramic) bypass capacitors.



6. FUNCTIONAL DESCRIPTION

6.1 General Description

W83783S provides at most 6 analog positive inputs, 3 fan speed monitors, 2 sets for fan PWM (Pulse Width Modulation) control, 2 thermal inputs from remote thermistors or 2N3904 transistors or Pentium™ II (Deschutes) thermal diode outputs and beep function output when the monitor value exceed the set limit value including voltage, temperature, or fan counter. When starting the monitor function on the chip, the watch dog machine monitor every function and store the value to registers. If the monitor value exceeds the limit value, the interrupt status will be set to 1.

6.2 Access Interface

W83783S provides I²C Serial Bus to read/write internal registers. In W83783S there are two serial bus addresses. The first address defined at CR [48h] can read/write all registers excluding Bank 1 temperature sensor registers and the address default value is 0101101. The second address defined at CR [4Ah] bit2-0 only read/write temperature sensor 1 registers and the address default value is 1001001.

6.2.1 The first serial bus access timing is shown as follow:

(a) Serial bus write to internal address register followed by the data byte

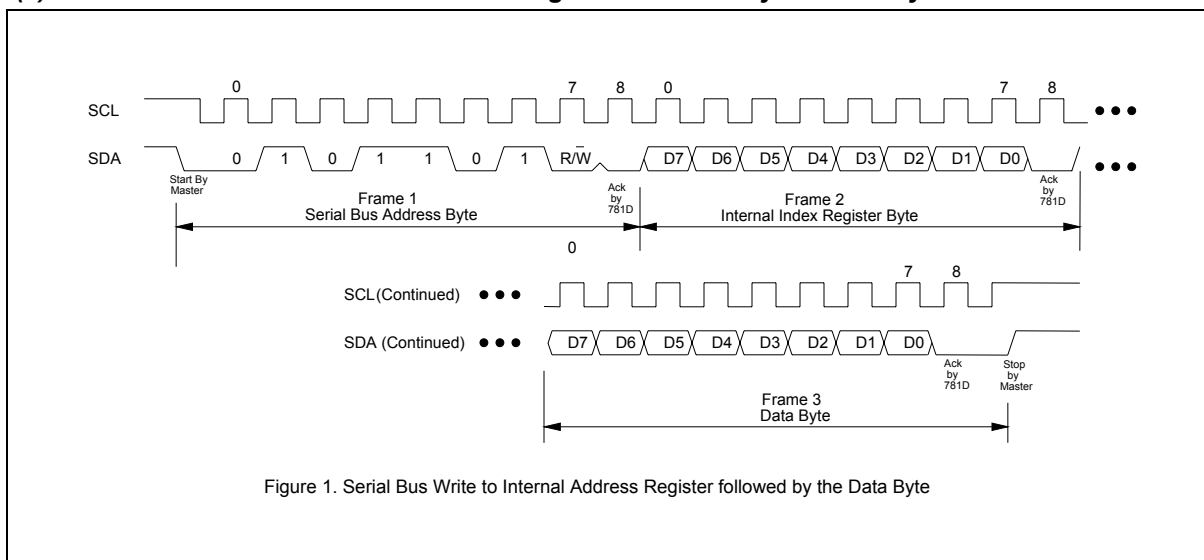
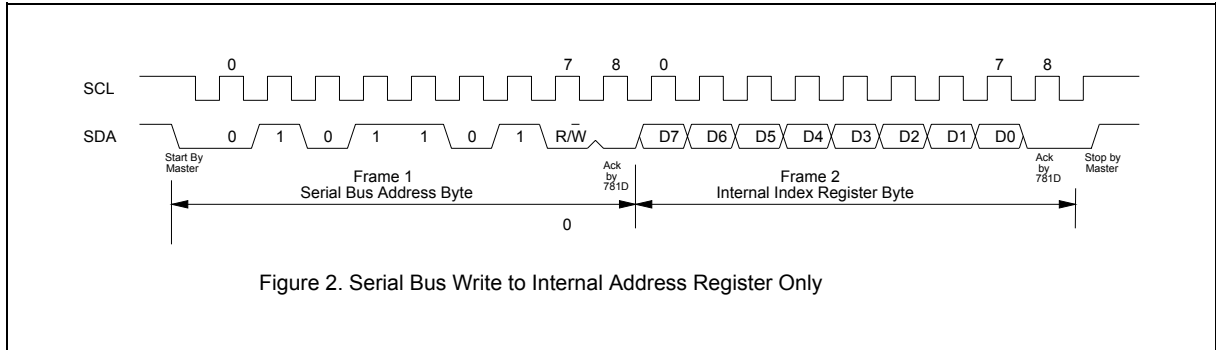

Figure 1. Serial Bus Write to Internal Address Register followed by the Data Byte



(b) Serial bus write to internal address register only



(c) Serial bus read from a register with the internal address register prefer to desired location

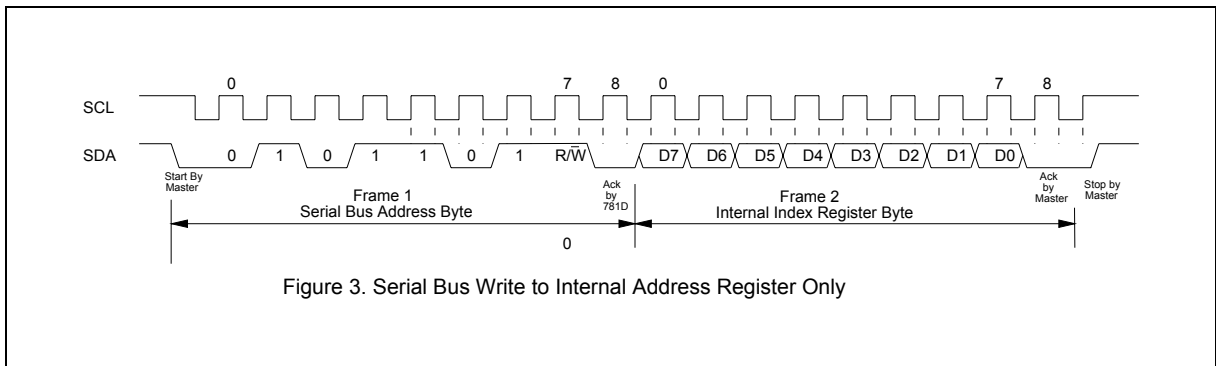

6.2.2 The serial bus timing of the temperature 2 and 3 is shown as follow:

(a) Typical 2-byte read from preset pointer location (Temp, T_{OS}, T_{HYST})

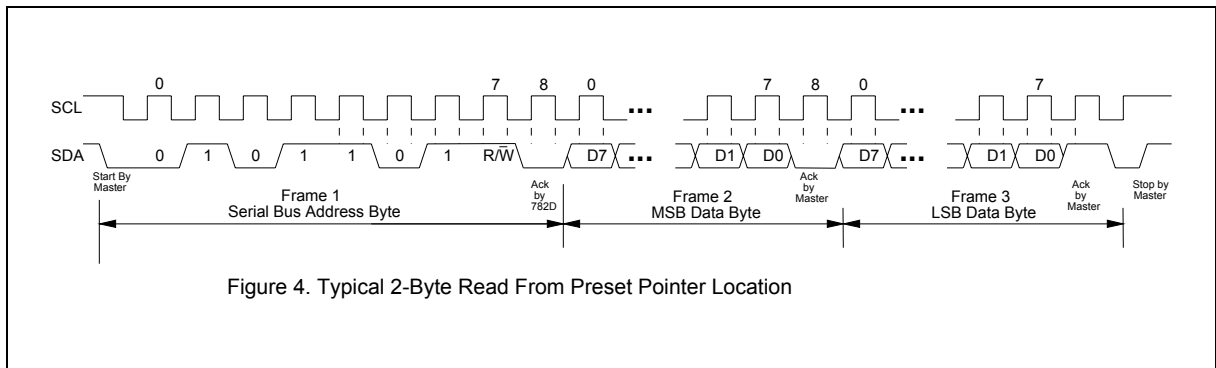



(b) Typical pointer set followed by immediate read for 2-byte register (Temp, T_{OS}, T_{HYST})

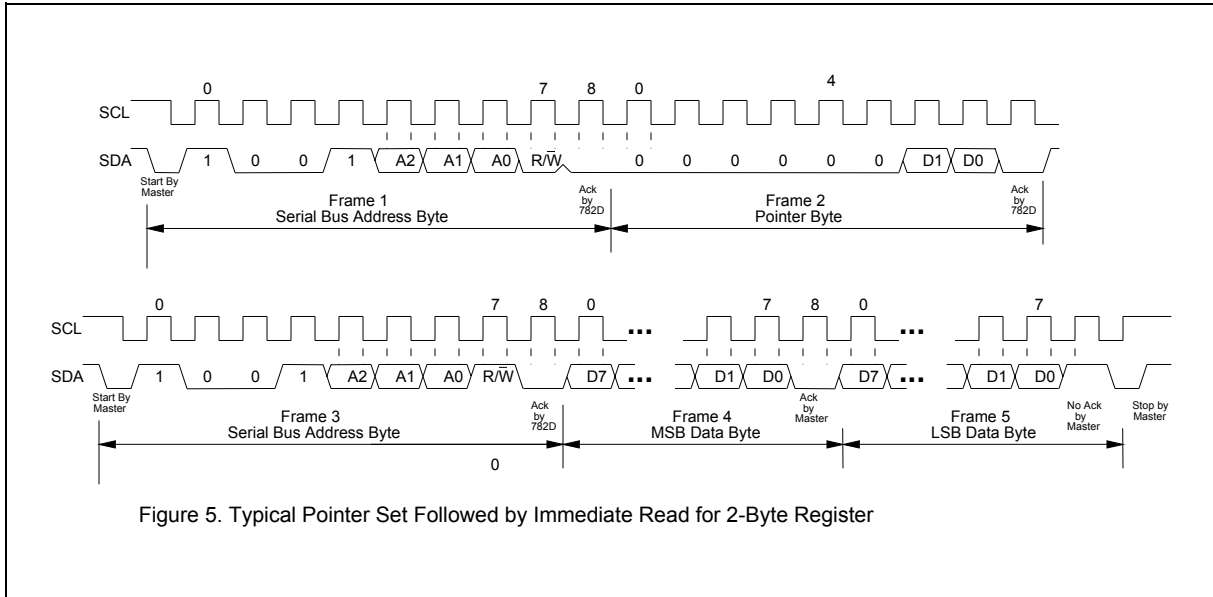

Figure 5. Typical Pointer Set Followed by Immediate Read for 2-Byte Register

(c) Typical read 1-byte from configuration register with preset pointer

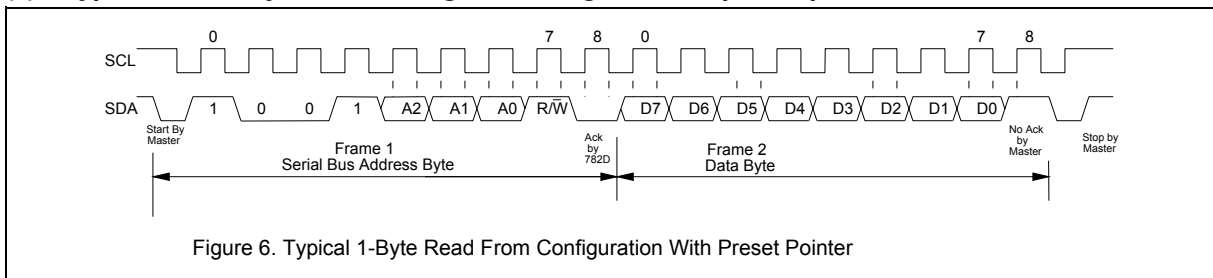
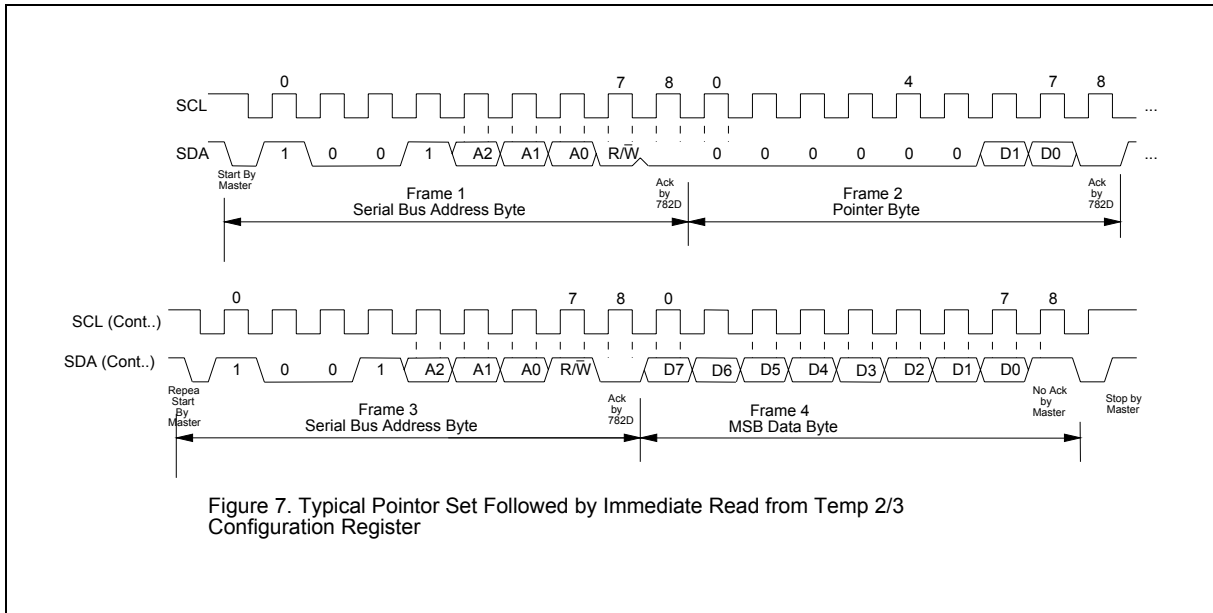

Figure 6. Typical 1-Byte Read From Configuration With Preset Pointer



(d) Typical pointer set followed by immediate read from configuration register



(e) Temperature 2/3 configuration register Write

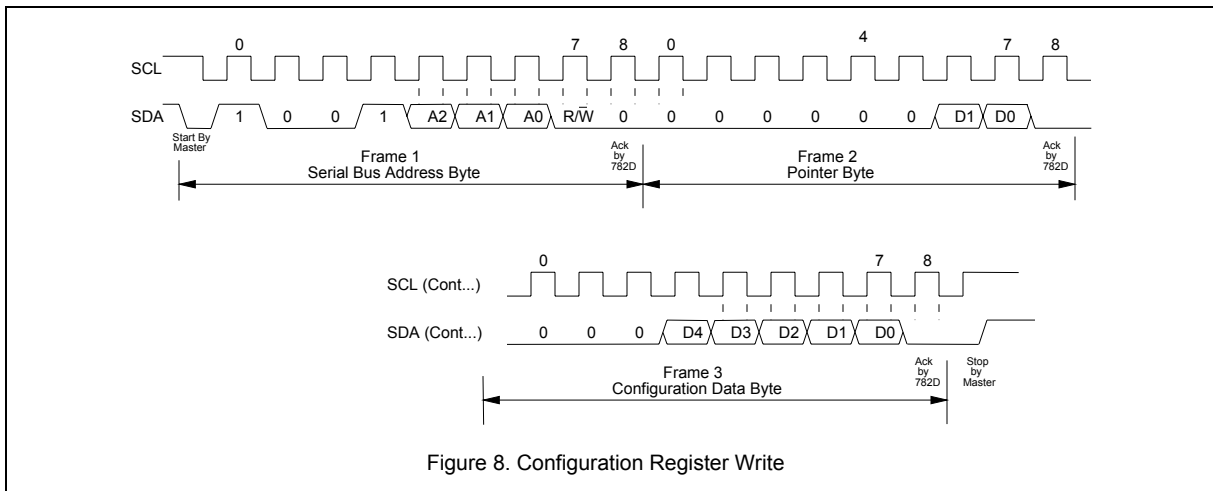



(f) Temperature 2/3 T_{OS} and T_{HYST} write

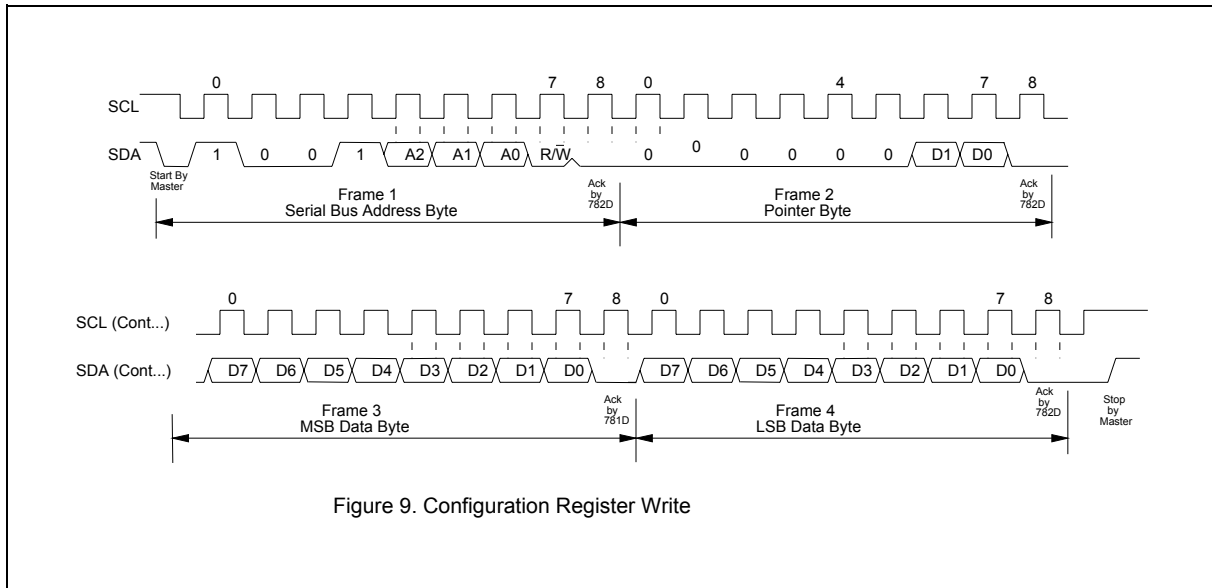

6.3 Analog Inputs

The maximum input voltage of the analog pin is 4.096V because the 8-bit ADC has a 16mv LSB. Really, the application of the PC monitoring would most often be connected to power suppliers. The CPU V-core voltage, +3.3V and battery voltage can directly connected to these analog inputs. The 5VSB and +12V inputs should be reduced a factor with external resistors so as to obtain the input range. As Figure 11 shows.

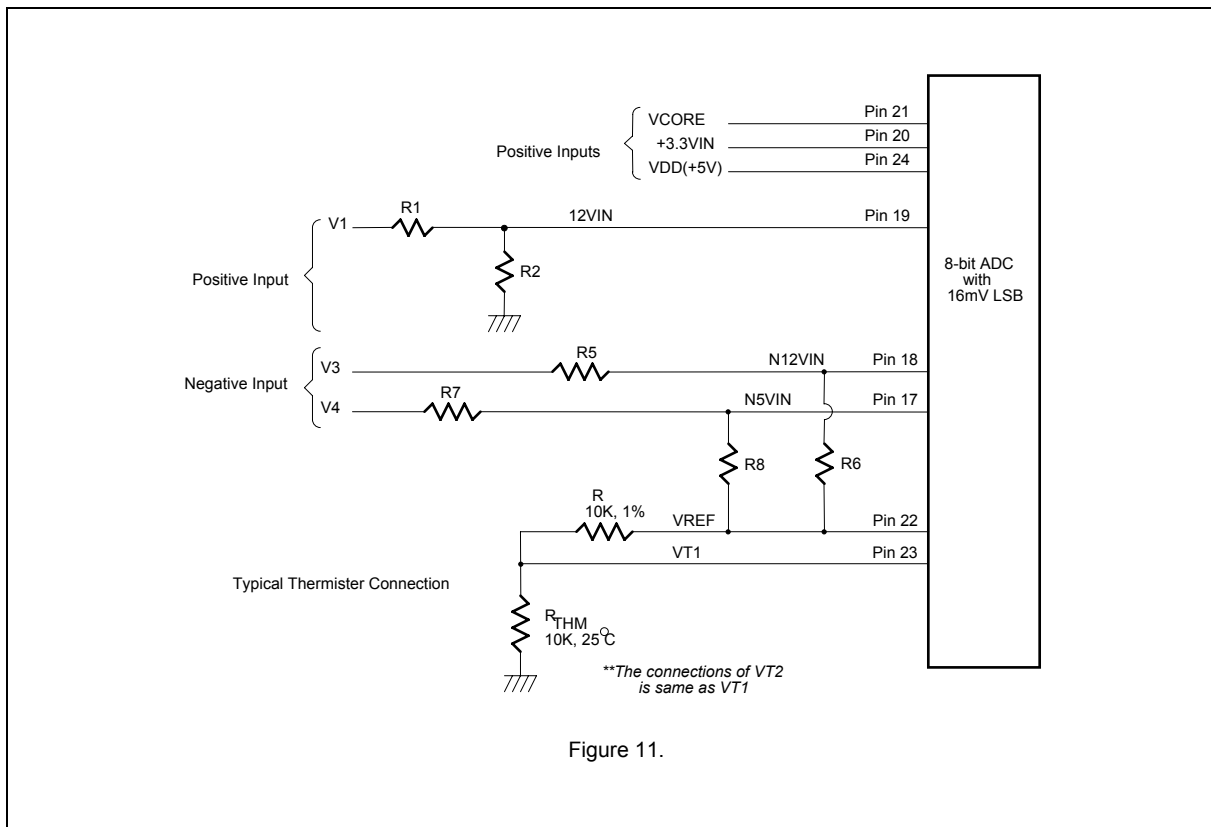

Figure 11.

6.3.1 Monitor over 4.096V voltage:

The input voltage +12VIN can be expressed as following equation.

$$12VIN = V_1 \times \frac{R_2}{R_1 + R_2}$$

The value of R1 and R2 can be selected to 28K Ohms and 10K Ohms, respectively, when the input voltage V1 is 12V. The node voltage of +12VIN can be subject to less than 4.096V for the maximum input range of the 8-bit ADC. The Pin 24 is connected to the power supply VCC with +5V. There are two functions in this pin with 5V. The first function is to supply internal analog power in W83783S and the second function is that this voltage with 5V is connected to internal serial resistors to monitor the +5V voltage. The values of two serial resistors are 34K ohms and 50K ohms so that input voltage to ADC is 2.98V which is less than 4.096V of ADC maximum input voltage. The express equation can represent as follows.

$$V_{in} = VCC \times \frac{50K\Omega}{50K\Omega + 34K\Omega} \cong 2.98V$$

where VCC is set to 5V.



6.3.2 Monitor negative voltage:

The negative voltage should be connected two series resistors and a positive voltage VREF (is equal to 3.6V). In the Figure 11, the voltage V3 and V4 are two negative voltages which they are -12V and -5V respectively. The voltage V3 is connected to two serial resistors then is connected to another terminal VREF which is positive voltage. So the voltage node N12VIN can obtain a positive voltage if the scales of the two serial resistors are carefully selected. It is recommended from Winbond that the scale of two serial resistors are R5=232K ohms and R6=56K ohm. The input voltage of node -12VIN can be calculated by following equation.

$$N12VIN = (VREF + |V_5|) \times \left(\frac{232K\Omega}{232K\Omega + 56K\Omega} \right) + V_5$$

where VREF is equal 3.6V.

If the V_5 is equal to -12V then the voltage is equal to 0.567V and the converted hexadecimal data is set to 35h by the 8-bit ADC with 16mV-LSB. This monitored value should be converted to the real negative voltage and the express equation is shown as follows.

$$V_5 = \frac{N12VIN - VREF \times \beta}{1 - \beta}$$

Where β is $232K/(232K+56K)$. If the N2VIN is 0.567 then the V5 is approximately equal to -12V.

Another negative voltage input V6 (approximate -5V) also can be evaluated by the similar method and the serial resistors can be selected with R7=120K ohms and R8=56K ohms by the Winbond recommended. The expression equation of V6 With -5V voltage is shown as follows.

$$V_6 = \frac{N5VIN - VREF \times \gamma}{1 - \gamma}$$

β is set to be $120K / (120K+56K)$. If the monitored ADC value in the N5VIN channel is 0.8635, VREF=3.6V and the parameter β is 0.6818 then the negative voltage of V6 can be evaluated to be -5V.



6.3.3 Monitor temperature from thermistor:

W83783S can connect three thermistors to measure three different environmental temperatures. The specification of thermistor should be considered to (1) β value is 3435K, (2) resistor value is 10K ohms at 25°C. In the Figure 11, the themistor is connected by a serial resistor with 10K Ohms, and then connect to VREF (Pin 37).

6.3.4 Monitor temperature from Pentium II™ thermal diode or bipolar transistor 2N3904

W83783S can alternate the thermistor to Pentium II™ (Deschutes) thermal diode interface or transistor 2N3904 and the circuit connection is shown as Figure 12. The pin of Pentium II™ D- is connected to power supply ground (GND) and the pin D+ is connected to pin PIITDx in W83783S. The resistor R=30K ohms should be connected to VREF to supply the diode bias current and the bypass capacitor C=3300pF should be added to filter the high frequency noise. The transistor 2N3904 should be connected to a form with a diode, that is, the Base (B) and Collector (C) in the 2N3904 should be tied together to act as a thermal diode.

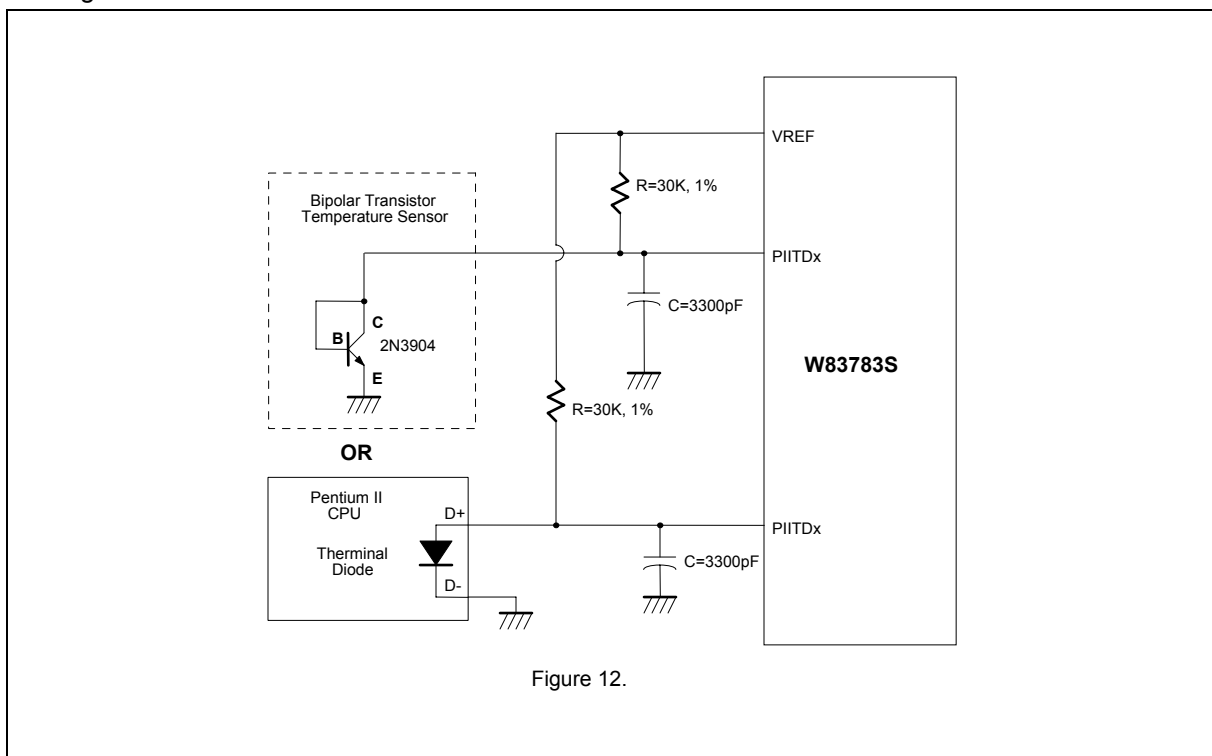



6.4 FAN Speed Count and FAN Speed Control

6.4.1 Fan speed count

Inputs are provided for signals from fans equipped with tachometer outputs. The level of these signals should be set to TTL level, and maximum input voltage can not be over +5.5V. If the input signals from the tachometer outputs are over the VCC, the external trimming circuit should be added to reduce the voltage to obtain the input specification. The normal circuit and trimming circuits are shown as Figure 13.

Determine the fan counter according to:

$$\text{Count} = \frac{1.35 \times 10^6}{\text{RPM} \times \text{Divisor}}$$

In other words, the fan speed counter has been read from register CR28 or CR29 or CR2A, the fan speed can be evaluated by the following equation.

$$\text{RPM} = \frac{1.35 \times 10^6}{\text{Count} \times \text{Divisor}}$$

The default divisor is 2 and defined at CR47.bit7~4, CR4B.bit7~6, and Bank0 CR5D.bit5~7 which are three bits for divisor. That provides very low speed fan counter such as power supply fan. The followed table is an example for the relation of divisor, PRM, and count.

Table 1

DIVISOR	NOMINAL PRM	TIME PER REVOLUTION	COUNTS	70% RPM	TIME FOR 70%
1	8800	6.82 ms	153	6160	9.74 ms
2 (default)	4400	13.64 ms	153	3080	19.48 ms
4	2200	27.27 ms	153	1540	38.96 ms
8	1100	54.54 ms	153	770	77.92 ms
16	550	109.08 ms	153	385	155.84 ms
32	275	218.16 ms	153	192	311.68 ms
64	137	436.32 ms	153	96	623.36 ms
128	68	872.64 ms	153	48	1246.72 ms

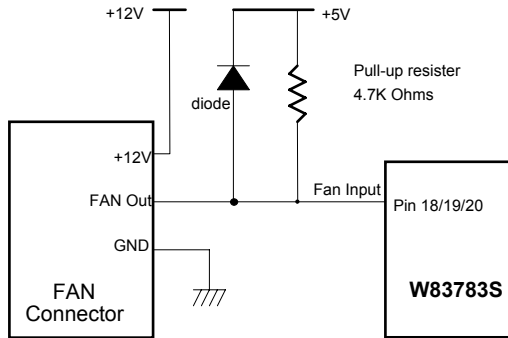

Figure 13-1. Fan with Tach Pull-Up to +5V

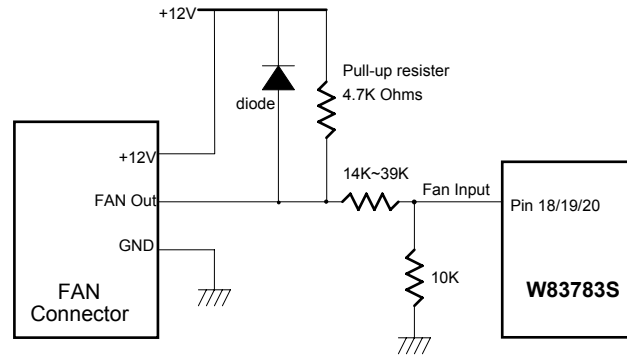

Figure 13-2. Fan with Tach Pull-Up to +12V, or Totem-Pole Output and Register Attenuator

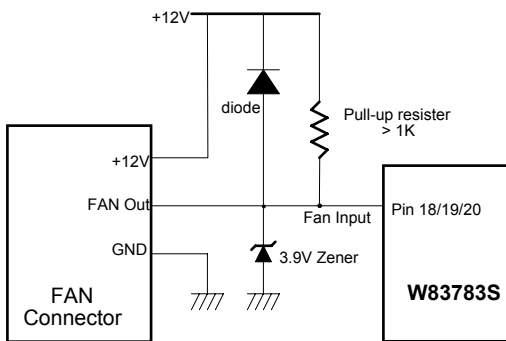

Figure 13-3. Fan with Tach Pull-Up to +12V and Zener Clamp

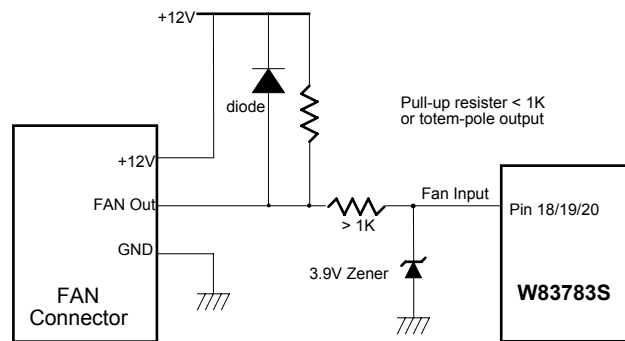

Figure 13-4. Fan with Tach Pull-Up to +12V, or Totem-Pole Output and Zener Clamp

6.4.2 Fan speed control

W83783S provides four sets for fan PWM speed control. The duty cycle of PWM can be programmed by a 8-bit registers which are defined in the Bank0 CR5A and CR5B. The default duty cycle is set to 100%, that is, the default 8-bit registers is set to FFh. The expression of duty can be represented as follows.

$$\text{Duty - cycle(\%)} = \frac{\text{Programmed 8 - bit Register Value}}{255} \times 100\%$$

The PWM clock frequency also can be program and defined in the Bank0 CR5C. The application circuit is shown as follows.

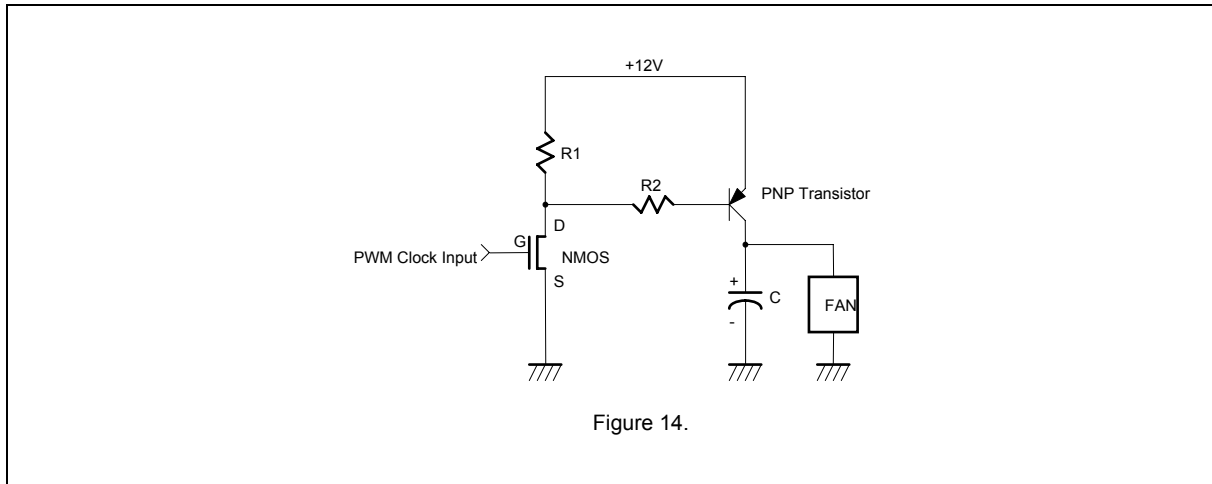

6.5 Temperature Measurement Machine

The temperature data format is 8-bit two-complement for sensor 2 and 9-bit two-complement for sensor 1. The 8-bit temperature data can be obtained by reading the CR [27h]. The 9-bit temperature data can be obtained by reading the 8 MSB from the Bank1 CR [50h] and the LSB from the Bank1 CR [51h] bit 7. The format of the temperature data is show in Table 2.

Table 2

TEMPERATURE	8-BIT DIGITAL OUTPUT		9-BIT DIGITAL OUTPUT	
	8-BIT BINARY	8-BIT HEX	9-BIT BINARY	9-BIT HEX
+125°C	0111,1101	7Dh	0,1111,1010	0FAh
+25°C	0001,1001	19h	0,0011,0010	032h
+1°C	0000,0001	01h	0,0000,0010	002h
+0.5°C	-	-	0,0000,0001	001h
+0°C	0000,0000	00h	0,0000,0000	000h
-0.5°C	-	-	1,1111,1111	1FFh
-1°C	1111,1111	FFh	1,1111,1110	1FFh
-25°C	1110,0111	E7h	1,1100,1110	1CEh
-55°C	1100,1001	C9h	1,1001,0010	192h



6.5.1 W83783S temperature sensor 2 SMI# interrupt has two modes:

(1) Comparator Interrupt Mode

Setting the T_{HYST} (Temperature Hysteresis) limit to 127°C will set temperature sensor 1 SMI# to the Comparator Interrupt Mode. Temperature exceeds T_O (Over Temperature) Limit causes an interrupt and this interrupt will be reset by reading all the Interrupt Status Register. Once an interrupt event has occurred by exceeding T_O , then reset, if the temperature remains above the T_O , the interrupt will occur again when the next conversion has completed. If an interrupt event has occurred by exceeding T_O and not reset, the interrupts will not occur again. The interrupts will continue to occur in this manner until the temperature goes below T_O . (Figure 15-1)

(2) Two-Times Interrupt Mode

Setting the T_{HYST} lower than T_O will set temperature sensor 1 SMI# to the Two-Times Interrupt Mode. Temperature exceeding T_O causes an interrupt and then temperature going below T_{HYST} will also cause an interrupt if the previous interrupt has been reset by reading all the interrupt Status Register. Once an interrupt event has occurred by exceeding T_O , then reset, if the temperature remains above the T_{HYST} , the interrupt will not occur. (Figure 15-2)

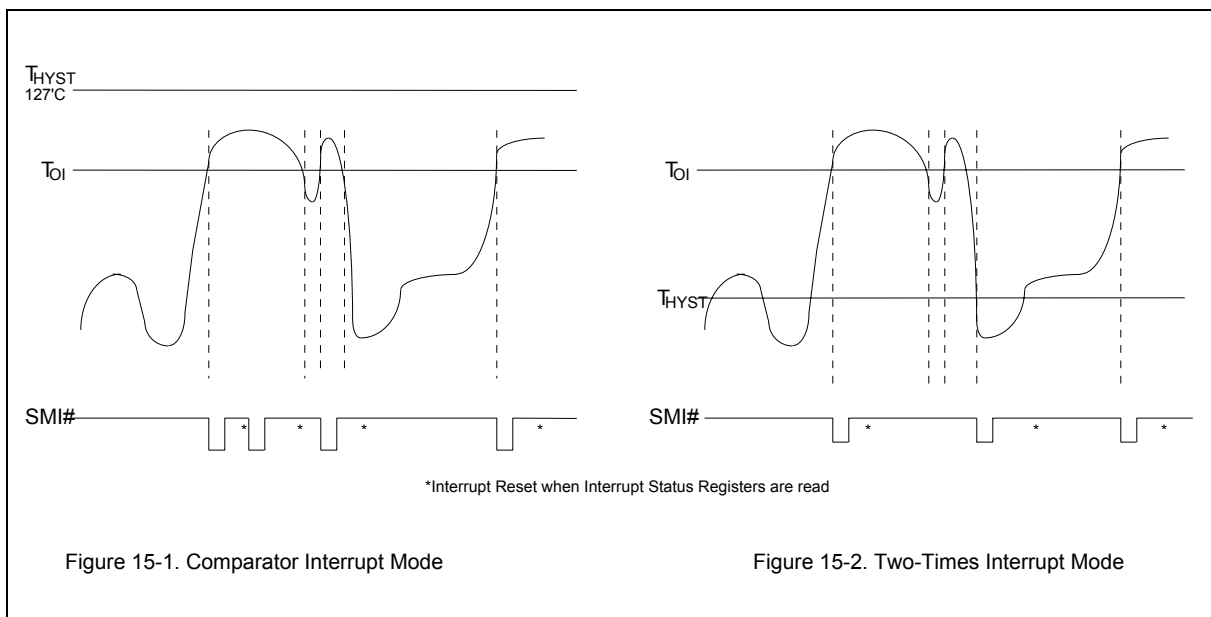



6.5.2 W83783S temperature sensor 1 SMI# interrupt has three modes

(1) Comparator Interrupt Mode

Temperature exceeding T_O causes an interrupt and this interrupt will be reset by reading all the Interrupt Status Register. Once an interrupt event has occurred by exceeding T_O , then reset, if the temperature remains above the T_{HYST} , the interrupt will occur again when the next conversion has completed. If an interrupt event has occurred by exceeding T_O and not reset, the interrupts will not occur again. The interrupts will continue to occur in this manner until the temperature goes below T_{HYST} . (Figure 16-1)

(2) Two-Times Interrupt Mode

Temperature exceeding T_O causes an interrupt and then temperature going below T_{HYST} will also cause an interrupt if the previous interrupt has been reset by reading all the interrupt Status Register. Once an interrupt event has occurred by exceeding T_O , then reset, if the temperature remains above the T_{HYST} , the interrupt will not occur. (Figure 16-2)

(3) One-Time Interrupt Mode

Temperature exceeding T_O causes an interrupt and then temperature going below T_{HYST} will not cause an interrupt. Once an interrupt event has occurred by exceeding T_O , then going below T_{HYST} , an interrupt will not occur again until the temperature exceeding T_O . (Figure 16-3)

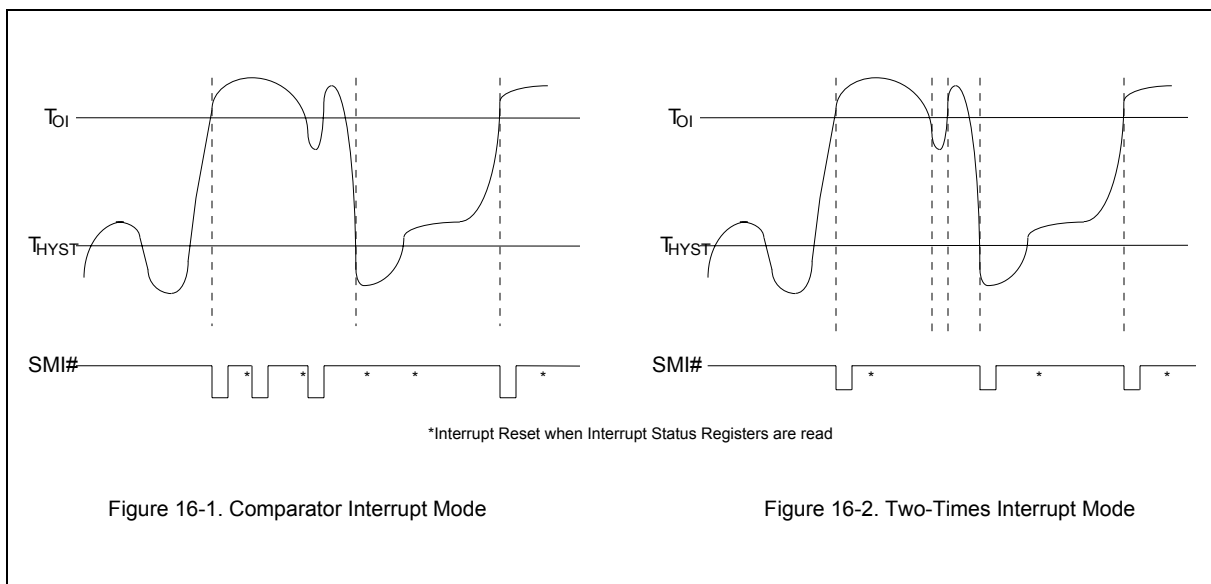

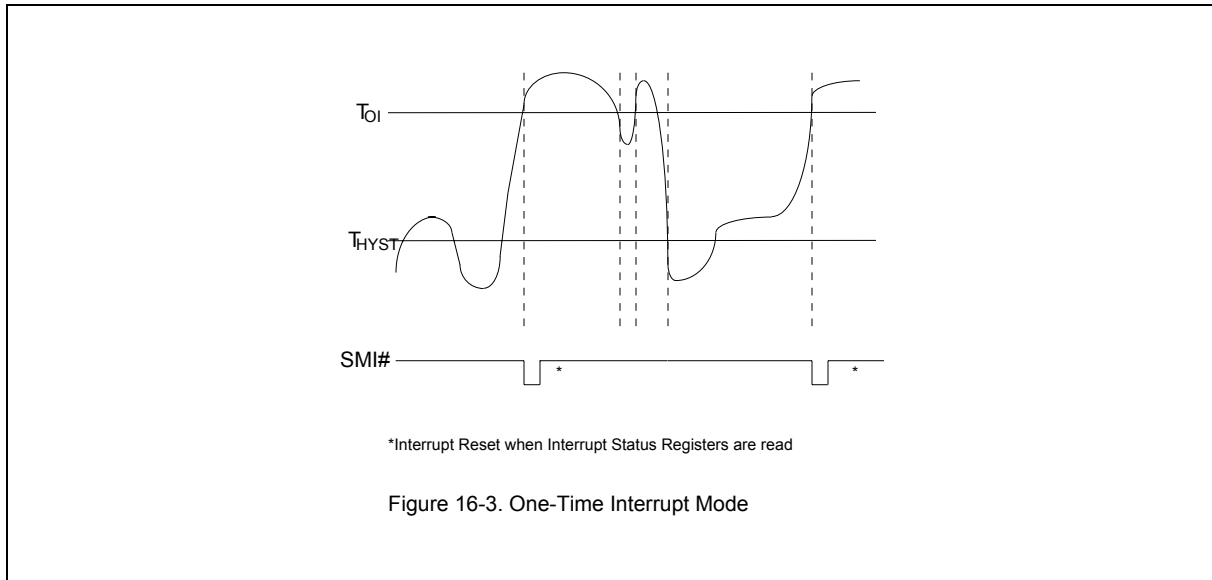

6.5.3 W83783S temperature sensor 1 Over-Temperature (OVT#) has three modes

(1) Comparator Mode:

Setting Bank1 CR [52h] bit 2 to 0 will set OVT# signal to comparator mode. Temperature exceeding T_O causes the OVT# output activated until the temperature is less than T_{HYST} . (Figure 17)

(2) Interrupt Mode:

Setting Bank1 CR [52h] bit 2 to 1 will set OVT# signal to interrupt mode. Setting Temperature exceeding T_O causes the OVT# output activated indefinitely until reset by reading temperature sensor 2 or sensor 3 registers. Temperature exceeding T_O , then OVT# reset, and then temperature going below T_{HYST} will also cause the OVT# activated indefinitely until reset by reading temperature sensor2 or sensor 3 registers. Once the OVT# is activated by exceeding T_O , then reset, if the temperature remains above T_{HYST} , the OVT# will not be activated again. (Figure 17)

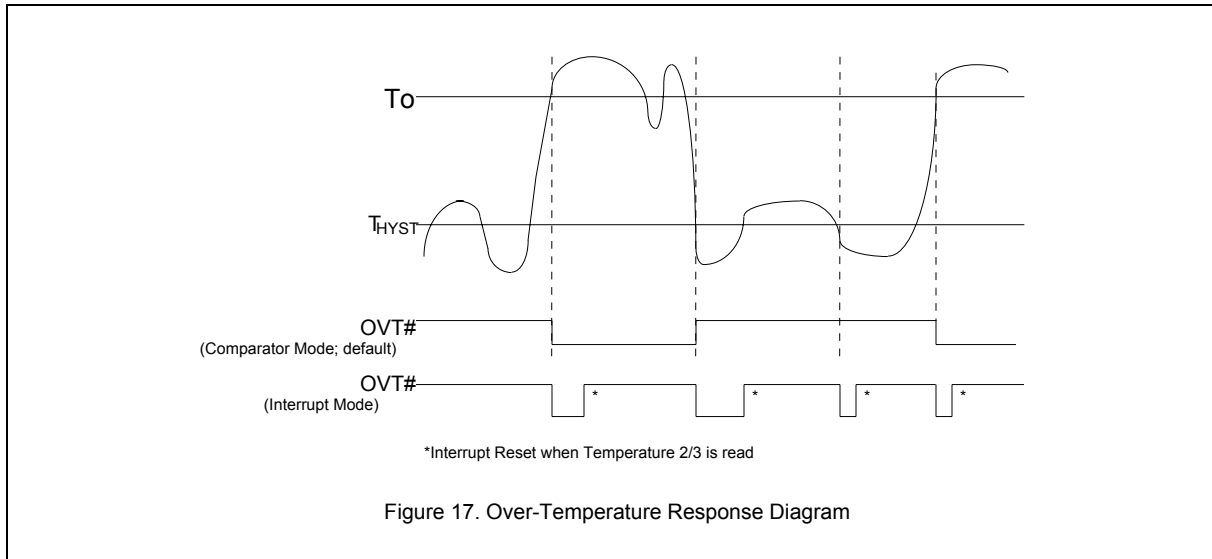

6.6 Voltage and Fan SMI# mode

6.6.1 Voltage SMI# mode

SMI# interrupt for voltage is Two-Times Interrupt Mode. Voltage exceeding high limit or going below low limit will causes an interrupt if the previous interrupt has been reset by reading all the interrupt Status Register. (Figure 18-1)

6.6.2 Fan SMI# mode

SMI# interrupt for fan is Two-Times Interrupt Mode. Fan count exceeding the limit, or exceeding and then going below the limit, will causes an interrupt if the previous interrupt has been reset by reading all the interrupt Status Register. (Figure 18-2)

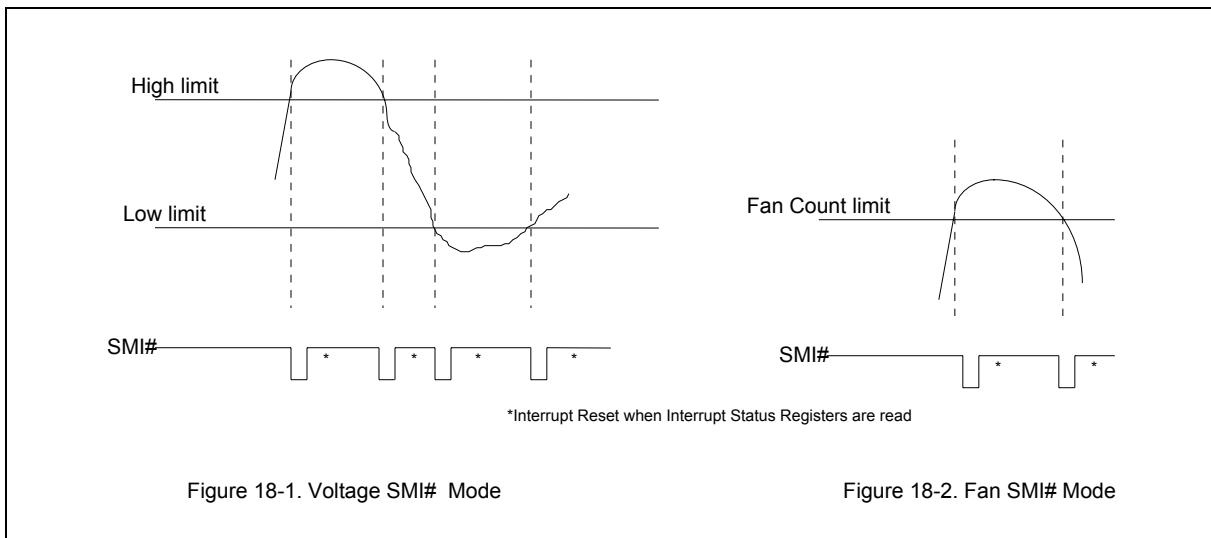

Figure 18-1. Voltage SMI# Mode

Figure 18-2. Fan SMI# Mode

7. REGISTERS AND RAM

7.1 Configuration Register — Index 40h

Register Location: 40h
 Power on Default Value 00000001 binary
 Attribute: Read/write
 Size: 8 bits

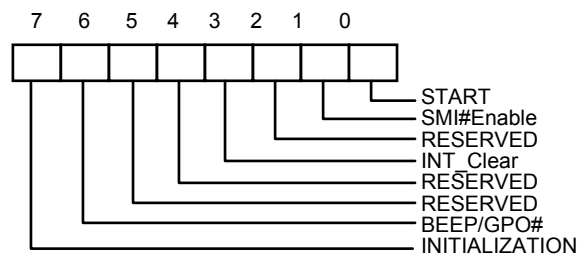

Bit 7: A one restores power on default value to all registers except the Serial Bus Address register. This bit clears itself since the power on default is zero.

Bit 6: The logical 1 in this bit drives a zero on BEEP/GPO# pin.

Bit 5: Reserved

Bit 4: Reserved

Bit 3: A one disables the SMI# output without affecting the contents of Interrupt Status Registers. The device will stop monitoring. It will resume upon clearing of this bit.

Bit 2: Reserved



Bit 1: A one enables the SMI# Interrupt output.

Bit 0: A one enables startup of monitoring operation, a zero puts the part in standby mode.

Note: The outputs of Interrupt pins will not be cleared if the user writes a zero to this location after an interrupt has occurred unlike "INT_Clear" bit.



7.2 Interrupt Status Register 1 — Index 41h

Register Location: 41h
 Power on Default Value 00h
 Attribute: Read Only
 Size: 8 bits

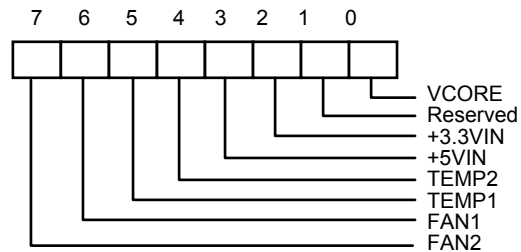

Bit 7: A one indicates the fan count limit of FAN2 has been exceeded.

Bit 6: A one indicates the fan count limit of FAN1 has been exceeded.

Bit 5: A one indicates a High limit of VT1 has been exceeded from temperature sensor.

Bit 4: A one indicates a High limit of VT2 has been exceeded from temperature sensor.

Bit 3: A one indicates a High or Low limit of +5VIN has been exceeded.

Bit 2: A one indicates a High or Low limit of +3.3VIN has been exceeded.

Bit 1: Reserved.

Bit 0: A one indicates a High or Low limit of VCORE has been exceeded.

7.3 Interrupt Status Register 2 — Index 42h

Register Location: 42h
 Power on Default Value 00h
 Attribute: Read Only
 Size: 8 bits

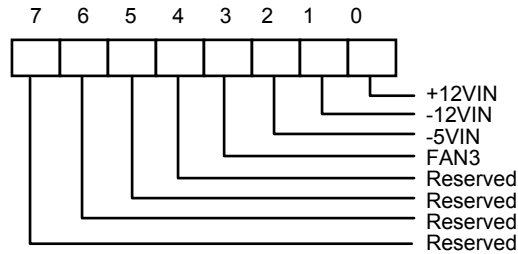

Bit 7-4:Reserved.This bit should be set to 0.

Bit 3: A one indicates the fan count limit of FAN3 has been exceeded.

Bit 2: A one indicates a High or Low limit of -5VIN has been exceeded.

Bit 1: A one indicates a High or Low limit of -12VIN has been exceeded.

Bit 0: A one indicates a High or Low limit of +12VIN has been exceeded.

7.4 SMI# Mask Register 1 — Index 43h

Register Location:	43h
Power on Default Value	00h
Attribute:	Read/Write
Size:	8 bits

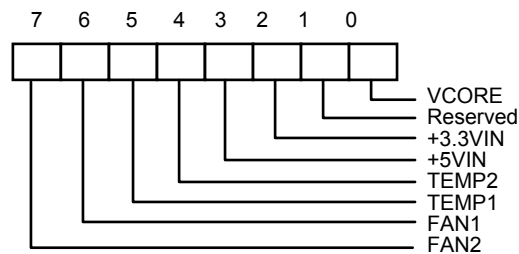

Bit 7-0: A one disables the corresponding interrupt status bit for $\overline{\text{SMI}}$ interrupt.



7.5 SMI# Mask Register 2 — Index 44h

Register Location: 44h
 Power on Default Value 00h
 Attribute: Read/Write
 Size: 8 bits

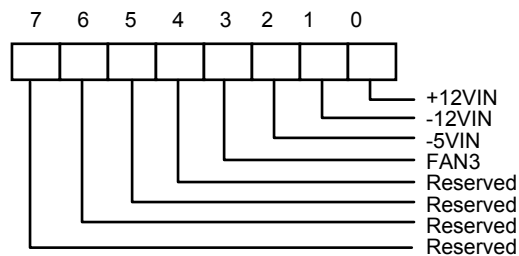

Bit 7-4: Reserved. This bit should be set to 0.

Bit 3-0: A one disables the corresponding interrupt status bit for $\overline{\text{SMI}}$ interrupt.

7.6 Reserved Register — Index 45h-- 46h



7.7 VID/Fan Divisor Register — Index 47h

Register Location: 47h

Power on Default Value <7:4> is 0101, <3:0> is mapped to VID<3:0>

Attribute: Read/Write

Size: 8 bits

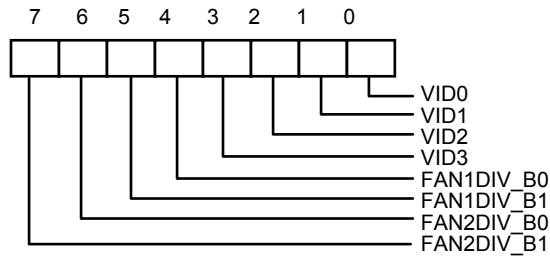

Bit 7-6: FAN2 Speed Control.

Bit 5-4: FAN1 Speed Control.

Bit 3-0: The VID <3:0> inputs

Note : Please refer to Bank0 CR[5Dh] , Fan divisor table.

7.8 Serial Bus Address Register — Index 48h

Register Location: 48h

Power on Default Value Serial Bus address <6:0> = 0101101 and <7> = 0 binary

Size: 8 bits

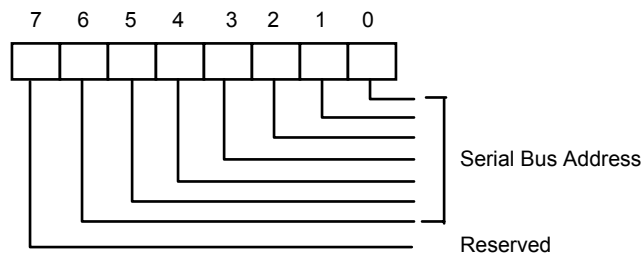

Bit 7: Read Only - Reserved.

Bit 6-0: Read/Write - Serial Bus address <6:0>.



7.9 Value RAM — Index 20h- 3Fh or 60h - 7Fh

INDEX	DESCRIPTION
20h or 60h	VCORE reading
21h or 61h	Reserved
22h or 62h	+3.3VIN reading
23h or 63h	+5VIN reading
24h or 64h	+12VIN reading
25h or 65h	-12VIN reading
26h or 66h	-5VIN reading
27h or 67h	Temperature sensor 2 (VT2) reading
28h or 68h	FAN1 reading Note: This location stores the number of counts of the internal clock per revolution.
29h or 69h	FAN2 reading Note: This location stores the number of counts of the internal clock per revolution.
2Ah or 6Ah	FAN3 reading Note: This location stores the number of counts of the internal clock per revolution.
2Bh or 6Bh	VCORE High Limit, default value is defined by Vcore Voltage +0.2v.
2Ch or 6Ch	VCORE Low Limit, default value is defined by Vcore Voltage -0.2v.
2Dh or 6Dh	Reserved
2Eh or 6Eh	Reserved
2Fh or 6Fh	+3.3VIN High Limit
30h or 70h	+3.3VIN Low Limit
31h or 71h	+5VIN High Limit
32h or 72h	+5VIN Low Limit

7.9 Value RAM — Index 20h- 3Fh or 60h - 7Fh, continued

ADDRESS A6-A0	DESCRIPTION
33h or 73h	+12VIN High Limit
34h or 74h	+12VIN Low Limit
35h or 75h	-12VIN High Limit
36h or 76h	-12VIN Low Limit
37h or 77h	-5VIN High Limit
38h or 78h	-5VIN Low Limit
39h or 79h	Temperature sensor 2 (VT2) High Limit
3Ah or 7Ah	Temperature sensor 2 (VT2) Hysteresis Limit
3Bh or 7Bh	FAN1 Fan Count Limit Note: It is the number of counts of the internal clock for the Low Limit of the fan speed.
3Ch or 7Ch	FAN2 Fan Count Limit Note: It is the number of counts of the internal clock for the Low Limit of the fan speed.
3Dh or 7Dh	FAN3 Fan Count Limit Note: It is the number of counts of the internal clock for the Low Limit of the fan speed.
3E- 3Fh or 7E-7Fh	Reserved

Setting all ones to the high limits for voltages and fans (0111 1111 binary for temperature) means interrupts will never be generated except the case when voltages go below the low limits.



7.10 Voltage ID (VID4) & Device ID — Index 49h

Register Location: 49h
 Power on Default Value <7:1> is 000,0001b
 <0> is mapped to VID <4>
 Size: 8 bits

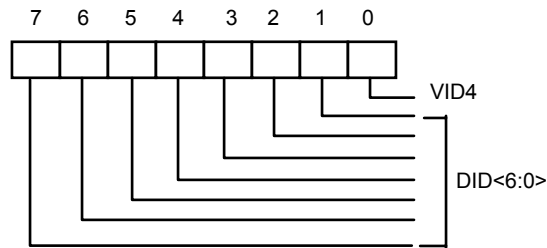

Bit 7-1: Read Only - Device ID<6:0>

Bit 0 : Read/Write - The VID4 inputs.

7.11 Temperature 2 and Temperature 3 Serial Bus Address Register — Index 4Ah

Register Location: 4Ah
 Power on Default Value <7:0> = 0000,0001 binary. Reset by MR
 Attribute: Read/Write
 Size: 8 bits

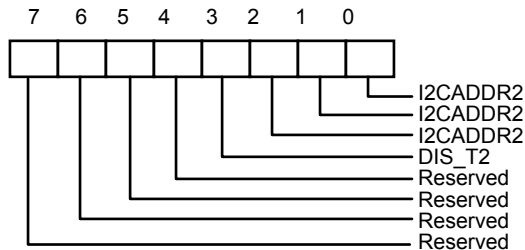

Bit 7-4 : Reserved

Bit 3: Set to 1, disable temperature Sensor 1 and can not access any data from Temperature Sensor 1.

Bit 2-0: Temperature 2 Serial Bus Address. The serial bus address is 1001xxx. Where xxx are defined in these bits.



7.12 Pin Control Register — Index 4Bh

Register Location: 4Bh
 Power on Default Value <7:0> 44h. Reset by MR.
 Attribute: Read/Write
 Size: 8 bits

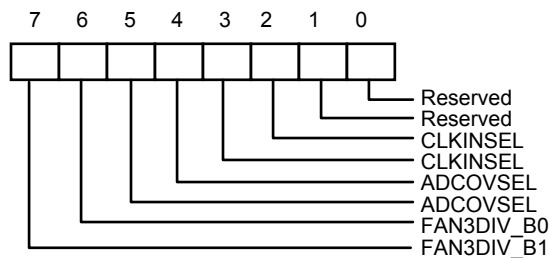

Bit 7-6: Fan3 speed divisor.

Please refer to Bank0 CR[5Dh] , Fan divisor table.

Bit 5-4: Select A/D Converter Clock Input.

<5:4> = 00 - default. ADC clock select 22.5 KHz.

<5:4> = 01 - ADC clock select 5.6 KHz. (22.5K/4)

<5:4> = 10 - ADC clock select 1.4KHz. (22.5K/16)

<5:4> = 11 - ADC clock select 0.35 KHz. (22.5K/64)

Bit 3-2: Clock Input Select.

<3:2> = 00 - Pin 3 (CLKIN) select 14.318M Hz clock.

<3:2> = 01 - Default. Pin 3 (CLKIN) select 24M Hz clock.

<3:2> = 10 - Pin 3 (CLKIN) select 48M Hz clock .

<3:2> = 11 - Reserved. Pin3 no clock input.

Bit 1-0: Reserved. User defined.



7.13 IRQ#/OVT# Property Select — Index 4Ch

Register Location: 4Ch
 Power on Default Value <7:0> --0000, 0001. Reset by MR.
 Attribute: Read/Write
 Size: 8 bits

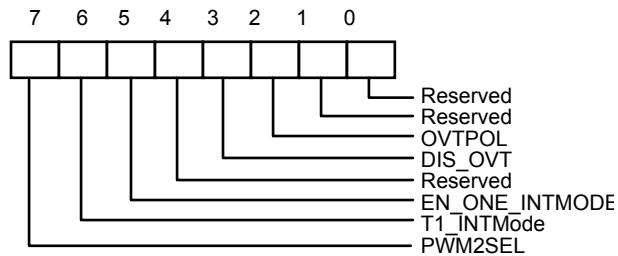

Bit 7: Set to 1, select pin 9 SMI#/PWMOUT2 as PWM output. Set to 0, select pin 9 as SMI# output.

Bit6: Set to 1, the SMI# output type of temperature sensor 1 is set to Comparator Interrupt mode. Set to 0, the SMI# output type is set to Interrupt mode (defined by CR [4Ch] Bit 5).

Bit 5: Set to 1, the SMI# output type of temperature sensor 1 is set to One-Time interrupt mode. Set to 0, the SMI# output type of temperature sensor 1 is set to Two-Times interrupt mode.

Bit 4: Reserved. User Defined.

Bit 3: Disable temperature sensor 1 over-temperature (OVT) output if set to 1. Default is 0, enable OVT1 output through pin OVT#.

Bit 2: Over-temperature polarity. Write 1, OVT# active high. Write 0, OVT# active low. Default is 0.

Bit 1-0: Reserved. User Defined.



7.14 FAN IN/OUT and BEEP/GPO# Control Register — Index 4Dh

Register Location: 4Dh
 Power on Default Value <7:0> 0001,0101. Reset by MR.
 Attribute: Read/Write
 Size: 8 bits

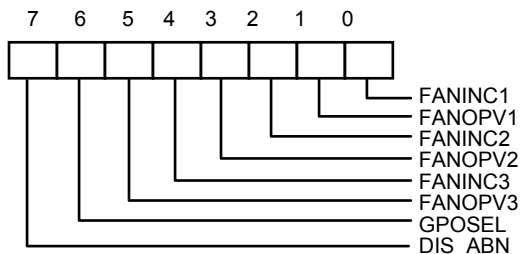

Bit 7: Disable power-on abnormal the monitor voltage including V-Core A and +3.3V. If these voltages exceed the limit value, the pin (Open Drain) of BEEP will drives 300Hz and 600Hz frequency signal. Write 1, the frequency will be disabled. Default is 0. After power on, the system should set 1 to this bit to 1 in order to disable BEEP.

Bit 6: BEEP/GPO# Pin Function Select. Write 1 Select GPO# function. Set 0, select BEEP function. This bit default 0.

Bit 5: FAN 3 output value if FANINC3 sets to 0. Write 1, then pin 4 always generate logic high signal. Write 0, pin 4 always generates logic low signal. This bit default 0.

Bit 4: FAN 3 Input Control. Set to 1, pin 4 acts as FAN clock input, which is default value. Set to 0, this pin 4 acts as FAN control signal and the output value of FAN control is set by this register bit 5. This output pin can connect to power PMOS gate to control FAN ON/OFF.

Bit 3: FAN 2 output value if FANINC2 sets to 0. Write 1, then pin 3 always generate logic high signal. Write 0, pin 3 always generates logic low signal. This bit default 0.

Bit 2: FAN 2 Input Control. Set to 1, pin 3 acts as FAN clock input, which is default value. Set to 0, this pin 3 acts as FAN control signal and the output value of FAN control is set by this register bit 3. This output pin can connect to power NMOS gate to control FAN ON/OFF.

Bit 1: FAN 1 output value if FANINC1 sets to 0. Write 1, then pin 2 always generate logic high signal. Write 0, pin 2 always generates logic low signal. This bit default 0.

Bit 0: FAN 1 Input Control. Set to 1, pin 2 acts as FAN clock input, which is default value. Set to 0, this pin 2 acts as FAN control signal and the output value of FAN control is set by this register bit 1. This output pin can connect to power PMOS gate to control FAN ON/OFF.



7.15 Register 50h ~ 5Fh Bank Select — Index 4Eh

Register Location: 4Eh
 Power on Default Value <6:3> = Reserved, <7> = 1, <2:0> = 0. Reset by MR
 Attribute: Read/Write
 Size: 8 bits

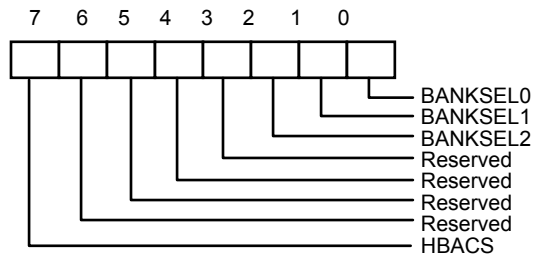

Bit 7: HBACS- High byte access. Set to 1, access Register 4Fh high byte register.

Set to 0, access Register 4Fh low byte register. Default 1.

Bit 6-3: Reserved. This bit should be set to 0.

Bit 2-0: Index ports 0x50~0x5F Bank select.

7.16 Winbond Vendor ID — Index 4Fh

Register Location: 4Fh
 Power on Default Value <15:0> = 5CA3h
 Attribute: Read Only
 Size: 16 bits

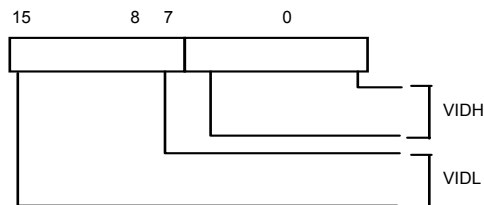

Bit 15-8: Vendor ID High Byte if CR4E.bit7=1.Default 5Ch.

Bit 7-0: Vendor ID Low Byte if CR4E.bit7=0. Default A3h.



7.17 Winbond Test Register — Index 50h - 55h (Bank 0)

7.18 BEEP Control Register 1 — Index 56h (Bank 0)

Register Location: 56h
 Power on Default Value <7:0> 0000,0000. Reset by MR.
 Attribute: Read/Write
 Size: 8 bits

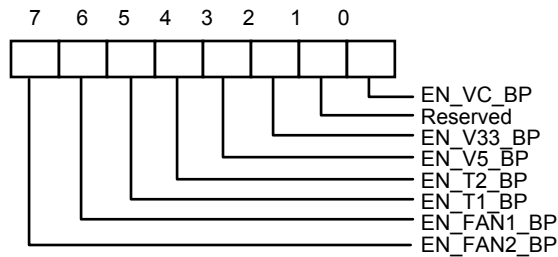

- Bit 7: Enable BEEP Output from FAN 2 if the monitor value exceeds the limit value. Write 1, enable BEEP output, which is default value.
- Bit 6: Enable BEEP Output from FAN 1 if the monitor value exceeds the limit value. Write 1, enable BEEP output, which is default value.
- Bit 5: Enable BEEP Output from Temperature Sensor 1 if the monitor value exceeds the limit value. Write 1, enable BEEP output. Default 0
- Bit 4: Enable BEEP output for Temperature Sensor 2 if the monitor value exceeds the limit value. Write 1, enable BEEP output. Default 0
- Bit 3: Enable BEEP output from VDD (+5V), Write 1, enable BEEP output if the monitor value exceeds the limits value. Default 0, that is disable BEEP output.
- Bit 2: Enable BEEP output from +3.3V. Write 1, enable BEEP output, which is default value.
- Bit 1: Reserved.
- Bit 0: Enable BEEP Output from VCORE if the monitor value exceeds the limits value. Write 1, enable BEEP output, which is default value



7.19 BEEP Control Register 2 — Index 57h (Bank 0)

Register Location: 57h

Power on Default Value <7:0> 1000-0000. Reset by MR.

Attribute: Read/Write

Size: 8 bits

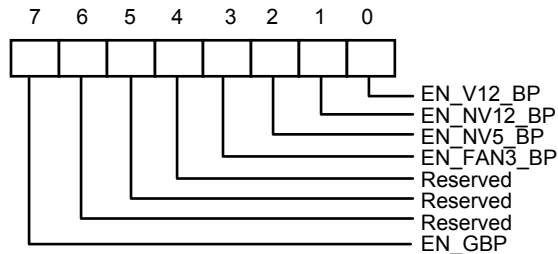

Bit 7: Enable Global BEEP. Write 1, enable global BEEP output. Default is 1. Write 0, disable all BEEP output.

Bit 6-4: Reserved.

Bit 3: Enable BEEP Output from FAN 3 if the monitor value exceeds the limit value. Write 1, enable BEEP output. Default is 0.

Bit 2: Enable BEEP output from -5V, Write 1, enable BEEP output if the monitor value exceed the limits value. Default is 0, that is disable BEEP output.

Bit 1: Enable BEEP output from -12V, Write 1, enable BEEP output if the monitor value exceed the limits value. Default is 0, that is disable BEEP output.

Bit 0: Enable BEEP output from +12V, Write 1, enable BEEP output if the monitor value exceed the limits value. Default is 0, that is disable BEEP output.



7.20 Chip ID — Index 58h (Bank 0)

Register Location: 58h
 Power on Default Value <7:0> 0100-0000. Reset by MR.
 Attribute: Read Only
 Size: 8 bits

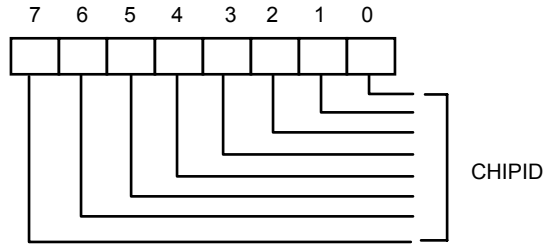

Bit 7: Winbond Chip ID number. Read this register will return 40h.

7.21 Diode Selection Register — Index 59h (Bank 0)

Register Location: 59h
 Power on Default Value <7>=0 and <6:4> = 111 and <3:0> = 0000
 Attribute: Read/Write
 Size: 8 bits

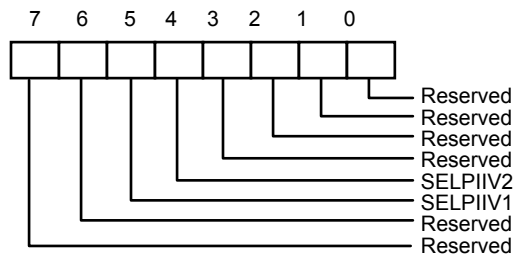

Bit 7-6: Reserved

Bit 5: Temperature sensor diode 1. Set to 1, select Pentium II compatible Diode. Set to 0 to select 2N3904 Bipolar mode.

Bit 4: Temperature sensor diode 2. Set to 1, select Pentium II compatible Diode. Set to 0 to select 2N3904 Bipolar mode.

Bit 3-0: Reserved



7.22 PWMOUT1 Control Register — Index 5Ah (Bank 0)

Register Location: 5Ah
 Power on default value: <7:0> 1111-1111. Reset by MR.
 Attribute: Read/Write
 Size: 8 bits

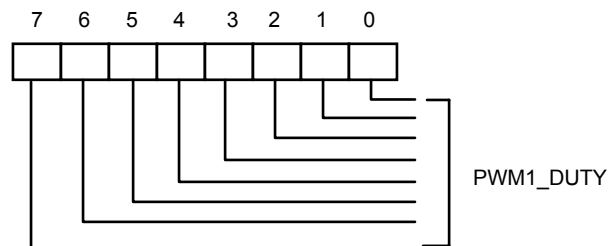

Bit 7: PWMOUT1 duty cycle control
 Write FF, Duty cycle is 100%, Write 00, Duty cycle is 0%.

7.23 PWMOUT2 Control Register — Index 5Bh (Bank 0)

Register Location: 5Bh
 Power on default value: <7:0> 1111-1111. Reset by MR.
 Attribute: Read/Write
 Size: 8 bits

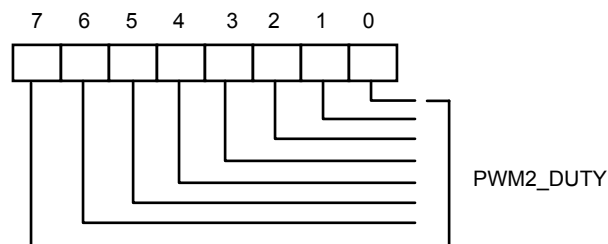

Bit 7: PWMOUT2 duty cycle control
 Write FF, Duty cycle is 100%,
 Write 00, Duty cycle is 0%.



7.24 PWMOUT1/2 Clock Select Register — Index 5Ch (Bank 0)

Register Location: 5Ch
 Power on Default Value <7:0> 0001-0001. Reset by MR.
 Attribute: Read/Write
 Size: 8 bits

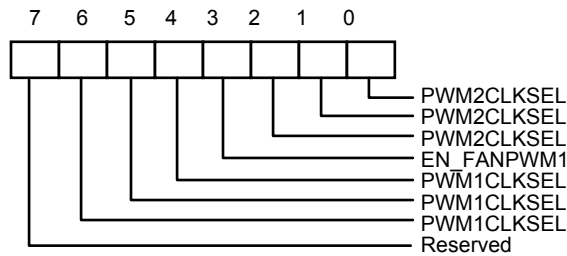

Bit 7: Reserved

Bit 6-4: PWMOUT1 clock selection.

The clock defined frequency is same as PWMOUT2 clock selection.

Bit 3: Set to 1. Enable PWMOUT1 PWM Control

Bit 2-0: PWMOUT2 clock Selection.

- <2:0> = 000: 46.87K Hz
- <2:0> = 001: 23.43K Hz (Default)
- <2:0> = 010: 11.72K Hz
- <2:0> = 011: 5.85K Hz
- <2:0> = 100: 2.93K Hz



7.25 VBAT Monitor Control Register — Index 5Dh (Bank 0)

Register Location: 5Dh
 Power on Default Value <7:0> 0000-0000. Reset by MR.
 Attribute: Read/Write
 Size: 8 bits

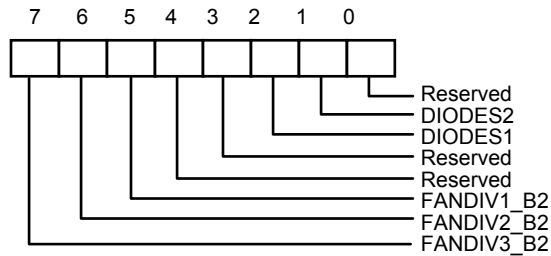

Bit 7: Fan3 divisor Bit 2.

Bit 6: Fan2 divisor Bit 2.

Bit 5: Fan1 divisor Bit 2.

Bit 4: Reserved

Bit 3: Reserved

Bit 2: Temperature sensor 1 select into thermal diode such as Pentium II CPU supported. Set to 1, select bipolar sensor. Set to 0, select thermistor sensor.

Bit 1: Temperature Sensor 2 type selection. Defined as DIODES1 described in the bit 2.

Bit 0: Reserved

Fan divisor table :

BIT 2	BIT 1	BIT 0	FAN DIVISOR	BIT 2	BIT 1	BIT 0	FAN DIVISOR
0	0	0	1	1	0	0	16
0	0	1	2	1	0	1	32
0	1	0	4	1	1	0	64
0	1	1	8	1	1	1	128



7.26 Reserved Register — Index 5Eh (Bank 0)

7.27 Reserved Register — Index 5Fh (Bank 0)

7.28 Temperature Sensor 1 Temperature (High Byte) Register — Index 00h

Register Location: 00h
 Attribute: Read Only
 Size: 8 bits

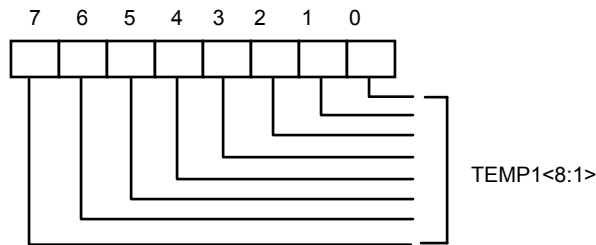

Bit 7: Temperature <8:1> of sensor 1, which is high byte.

7.29 Temperature Sensor 1 Temperature (Low Byte) Register — Index 00h

Register Location: 00h
 Attribute: Read Only
 Size: 8 bits

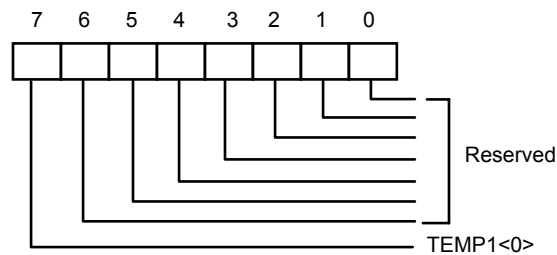

Bit 7: Temperature <0> of sensor1, which is low byte.

Bit 6-0: Reserved. This bit should be set to 0.



7.30 Temperature Sensor 1 Configuration Register — Index 01h

Register Location: 01h
 Power on Default Value <7:0> = 0x00
 Size: 8 bits

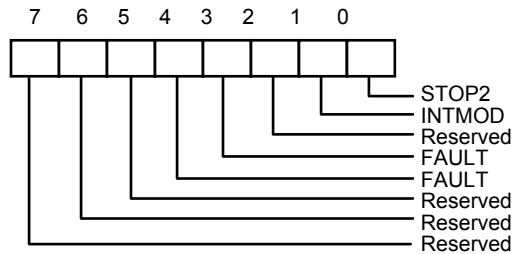

Bit 7-5: Read - Reserved. This bit should be set to 0.

Bit 4-3: Read/Write - Number of faults to detect before setting OVT# output to avoid false tripping due to noise.

Bit 2: Read - Reserved. This bit should be set to 0.

Bit 1: Read/Write - OVT# Interrupt mode select. This bit default is set to 0, which is compared mode. When set to 1, interrupt mode will be selected.

Bit 0: Read/Write - When set to 1 the sensor will stop monitor.



7.31 Temperature Sensor 1 Hysteresis (High Byte) Register — Index 02h

Register Location: 02h
 Power on Default Value <7:0> = 0x4B
 Attribute: Read/Write
 Size: 8 bits

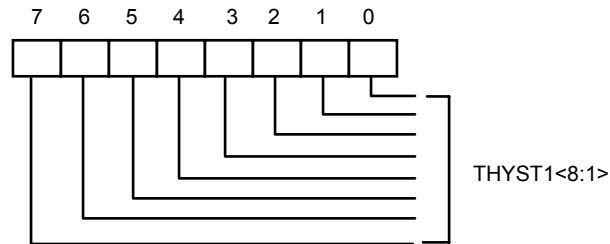

Bit 7-0: Temperature hysteresis bit 8-1, which is High Byte. The temperature default 75 degree C.

7.32 Temperature Sensor 1 Hysteresis (Low Byte) Register — Index 02h

Register Location: 02h
 Power on Default Value <7:0> = 0x0
 Attribute: Read Only
 Size: 8 bits

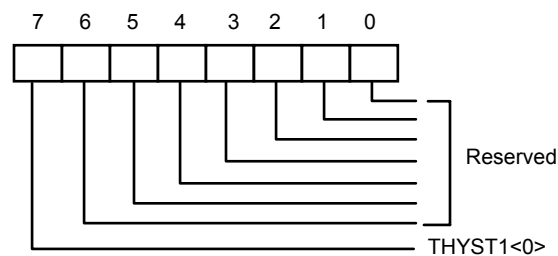

Bit 7: Temperature hysteresis bit 0, which is low Byte.

Bit 6-0: Reserved. This bit should be set to 0.



7.33 Temperature Sensor 1 Over-temperature (High Byte) Register — Index 03h

Register Location: 03h
 Power on Default Value <7:0> = 0x50
 Attribute: Read/Write
 Size: 8 bits

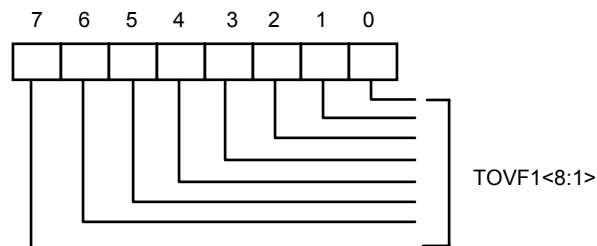

Bit 7-0: Over-temperature bit 8-1, which is High Byte. The temperature default 80 degree C.

7.34 Temperature Sensor 1 Over-temperature (Low Byte) Register — Index 03h

Register Location: 03h
 Power on Default Value <7:0> = 0x0
 Size: 8 bits

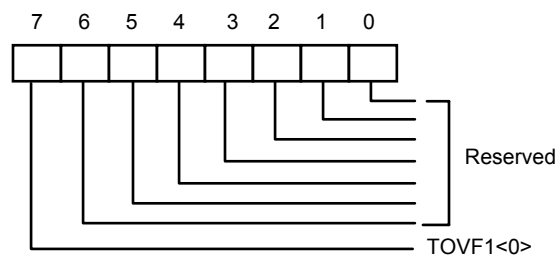

Bit 7: Read/Write - Over-temperature bit 0, which is low Byte.

Bit 6-0: Read Only - Reserved. This bit should be set to 0.



7.35 Reserved Register — Index 50h--52h (BANK4)

7.36 BEEP Control Register 3 — Index 53h (Bank 4)

Register Location: 53h
 Power on Default Value <7:0> 0000,0000. Reset by MR.
 Attribute: Read/Write
 Size: 8 bits

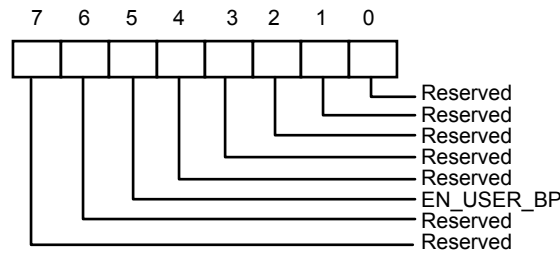

Bit 7-6: Reserved.

Bit 5: User defines BEEP output function. Write 1, the BEEP is always active. Write 0, this function is inactive. (Default 0)

Bit 4-0: Reserved.

7.37 Reserved Register — Index 54h--58h (Bank 4)

7.38 Real Time Hardware Status Register I — Index 59h (Bank 4)

Register Location: 59h
 Power on Default Value <7:0> 0000,0000. Reset by MR.
 Attribute: Read Only
 Size: 8 bits

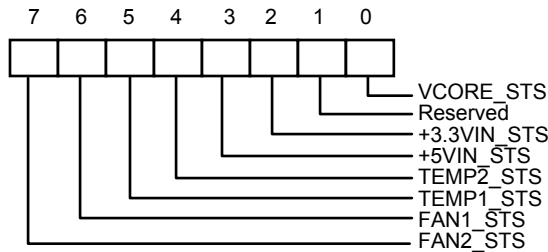



- Bit 7: FAN 2 Status. Set 1, the fan speed counter is over the limit value. Set 0, the fan speed counter is in the limit range.
- Bit 6: FAN 1 Status. Set 1, the fan speed counter is over the limit value. Set 0, the fan speed counter is in the limit range.
- Bit 5: Temperature sensor 1 Status. Set 1, the voltage of temperature sensor is over the limit value. Set 0, the voltage of temperature sensor is in the limit range.
- Bit 4: Temperature sensor 2 Status. Set 1, the voltage of temperature sensor is over the limit value. Set 0, the voltage of temperature sensor is in the limit range.
- Bit 3: +5V Voltage Status. Set 1, the voltage of +5V is over the limit value. Set 0, the voltage of +5V is in the limit range.
- Bit 2: +3.3V Voltage Status. Set 1, the voltage of +3.3V is over the limit value. Set 0, the voltage of +3.3V is in the limit range.
- Bit 1: Reserved.
- Bit 0: VCORE Voltage Status. Set 1, the voltage of VCORE is over the limit value. Set 0, the voltage of VCORE is in the limit range.

7.39 Real Time Hardware Status Register II — Index 5Ah (Bank 4)

Register Location: 5Ah
 Power on Default Value <7:0> 0000,0000. Reset by MR.
 Attribute: Read Only
 Size: 8 bits

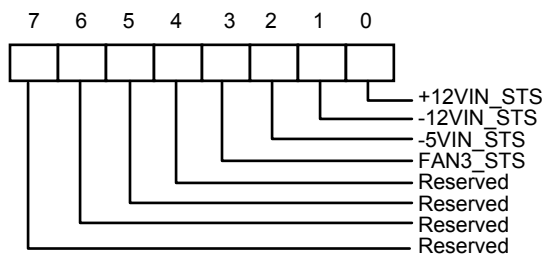



Bit 7-4: Reserved

Bit 3: FAN3 Voltage Status. Set 1, the fan speed counter is over the limit value. Set 0, the fan speed counter is during the limit range.

Bit 2: -5V Voltage Status. Set 1, the voltage of -5V is over the limit value. Set 0, the voltage of -5V is during the limit range.

Bit 1: -12V Voltage Status. Set 1, the voltage of -12V is over the limit value. Set 0, the voltage of -12V is during the limit range.

Bit 0: +12V Voltage Status. Set 1, the voltage of +12V is over the limit value. Set 0, the voltage of +12V is in the limit range.



8. SPECIFICATIONS

8.1 Absolute Maximum Ratings

PARAMETER	RATING	UNIT
Power Supply Voltage	-0.5 to 7.0	V
Input Voltage	-0.5 to VDD+0.5	V
Operating Temperature	0 to +70	°C
Storage Temperature	-55 to +150	°C

Note: Exposure to conditions beyond those listed under Absolute Maximum Ratings may adversely affect the life and reliability of the device.

8.2 DC Characteristics

(Ta = 0° C to 70° C, VDD = 5V ± 10%, VSS = 0V)

PARAMETER	SYM.	MIN.	TYP.	MAX.	UNIT	CONDITIONS
I/O_{12t} - TTL level bi-directional pin with source-sink capability of 12 mA						
Input Low Voltage	V _{IL}			0.8	V	
Input High Voltage	V _{IH}	2.0			V	
Output Low Voltage	V _{OL}			0.4	V	I _{OL} = 12 mA
Output High Voltage	V _{OH}	2.4			V	I _{OH} = - 12 mA
Input High Leakage	I _{LIH}			+10	μA	V _{IN} = VDD
Input Low Leakage	I _{LIL}			-10	μA	V _{IN} = 0V
I/O_{12ts} - TTL level bi-directional pin with source-sink capability of 12 mA and schmitt-trigger level input						
Input Low Threshold Voltage	V _{t-}	0.5	0.8	1.1	V	VDD = 5 V
Input High Threshold Voltage	V _{t+}	1.6	2.0	2.4	V	VDD = 5 V
Hysteresis	V _{TH}	0.5	1.2		V	VDD = 5 V
Output Low Voltage	V _{OL}			0.4	V	I _{OL} = 12 mA
Output High Voltage	V _{OH}	2.4			V	I _{OH} = - 12 mA
Input High Leakage	I _{LIH}			+10	μA	V _{IN} = VDD
Input Low Leakage	I _{LIL}			-10	μA	V _{IN} = 0V



8.2 DC Characteristics, continued

PARAMETER	SYM.	MIN.	TYP.	MAX.	UNIT	CONDITIONS
OUT_{12t} - TTL level output pin with source-sink capability of 12 mA						
Output Low Voltage	VOL			0.4	V	IOL = 12 mA
Output High Voltage	VOH	2.4			V	IOH = -12 mA
OD₈ - Open-drain output pin with sink capability of 8 mA						
Output Low Voltage	VOL			0.4	V	IOL = 8 mA
OD₁₂ - Open-drain output pin with sink capability of 12 mA						
Output Low Voltage	VOL			0.4	V	IOL = 12 mA
OD₄₈ - Open-drain output pin with sink capability of 48 mA						
Output Low Voltage	VOL			0.4	V	IOL = 48 mA
IN_t - TTL level input pin						
Input Low Voltage	VIL			0.8	V	
Input High Voltage	VIH	2.0			V	
Input High Leakage	ILIH			+10	μA	VIN = VDD
Input Low Leakage	ILIL			-10	μA	VIN = 0 V
IN_{ts} - TTL level Schmitt-triggered input pin						
Input Low Threshold Voltage	Vt-	0.5	0.8	1.1	V	VDD = 5 V
Input High Threshold Voltage	Vt+	1.6	2.0	2.4	V	VDD = 5 V
Hysteresis	VTH	0.5	1.2		V	VDD = 5 V
Input High Leakage	ILIH			+10	μA	VIN = VDD
Input Low Leakage	ILIL			-10	μA	VIN = 0 V



8.3 AC Characteristics

8.3.1 Serial Bus Timing Diagram

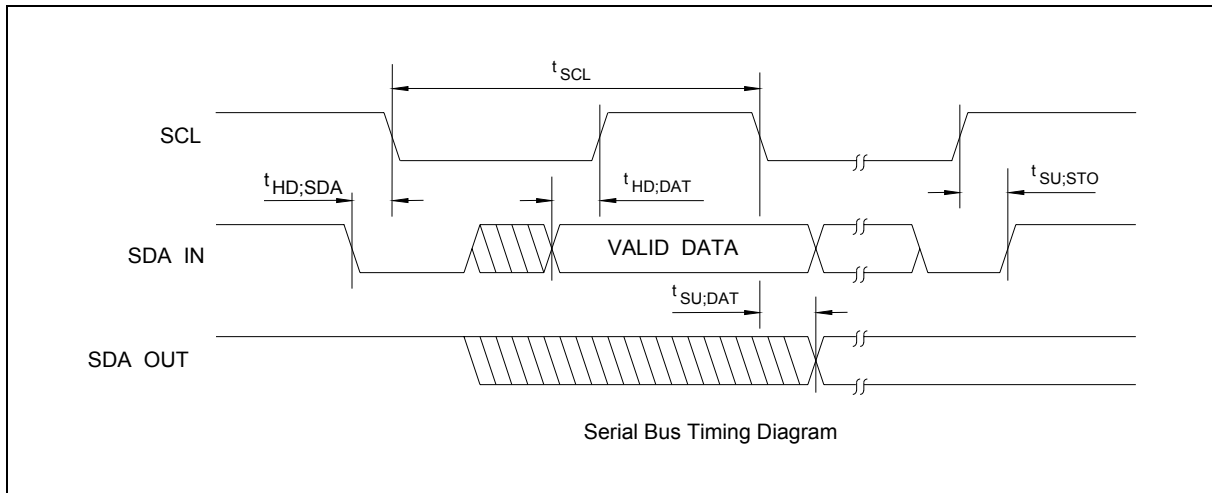

Serial Bus Timing

PARAMETER	SYMBOL	MIN.	MAX.	UNIT
SCL clock period	t_{SCL}	10		uS
Start condition hold time	$t_{HD;SDA}$	4.7		uS
Stop condition setup-up time	$t_{SU;STO}$	4.7		uS
DATA to SCL setup time	$t_{SU;DAT}$	120		nS
DATA to SCL hold time	$t_{HD;DAT}$	5		nS
SCL and SDA rise time	t_R		1.0	uS
SCL and SDA fall time	t_F		300	nS



9. HOW TO READ THE TOP MARKING

The top marking of W83783S



Left: Winbond logo

1st line: Winbond logo and the type number: W83783S

2nd line: Tracking code 2 826978Y-61

2: wafers manufactured in Winbond FAB 2

826978Y-61: wafer production series lot number

3rd line: Tracking code 814 O B

814: packages made in '98, week 14

O: assembly house ID; A means ASE, S means SPIL, O means OSE

B: IC revision



10. PACKAGE DIMENSIONS

(24-pin SOP)

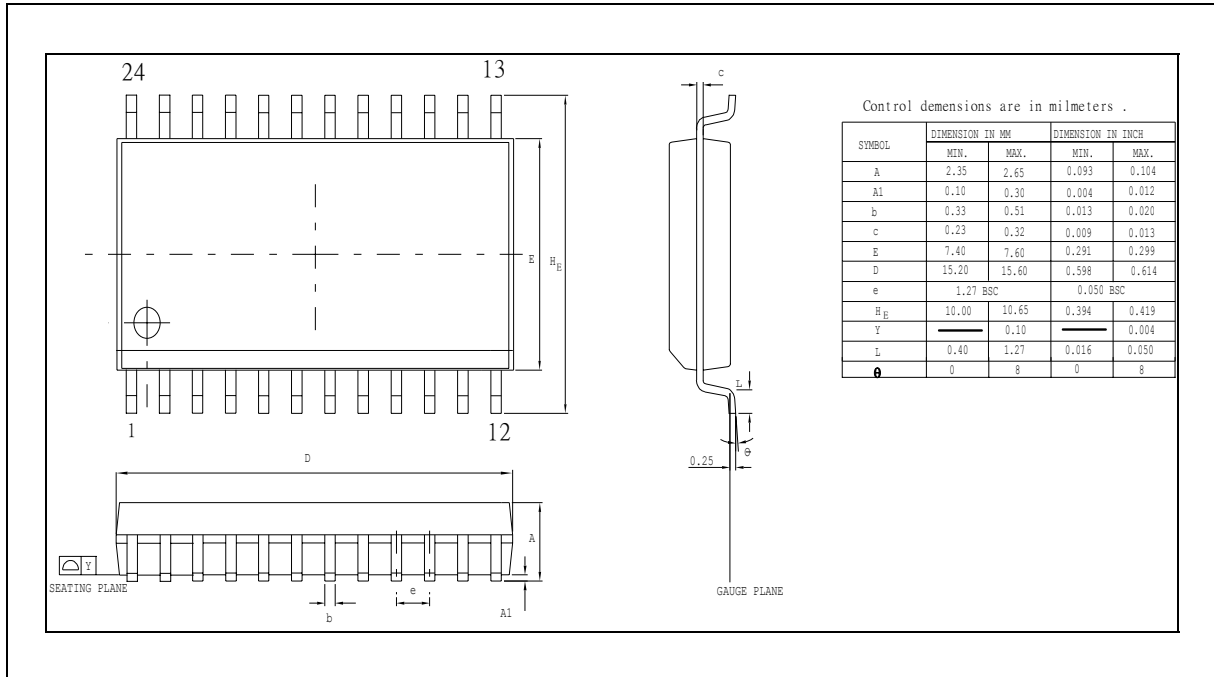



11. APPLICATION CIRCUIT OF WINBOND W83783S

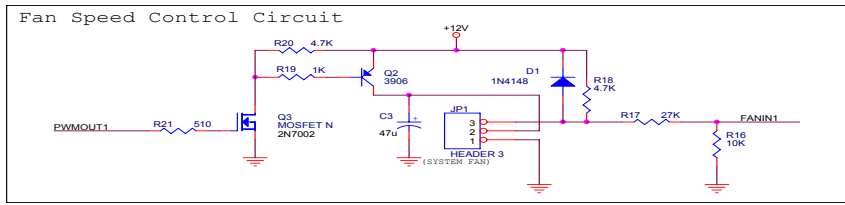
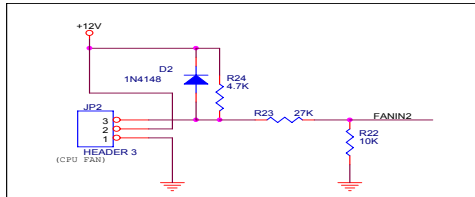
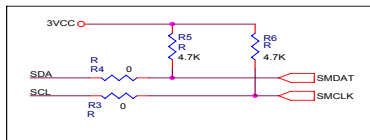
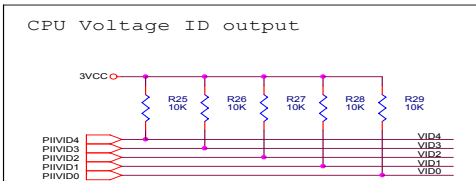
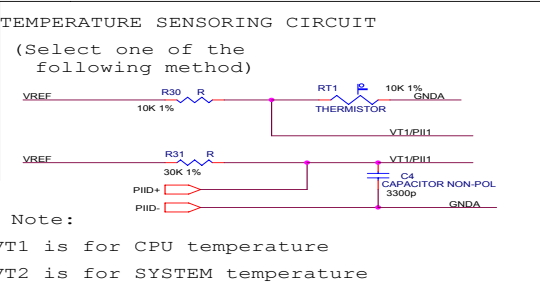
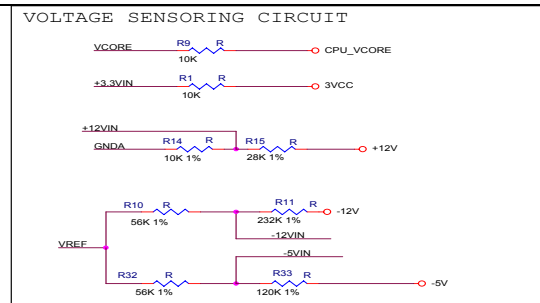
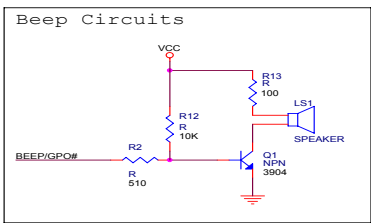
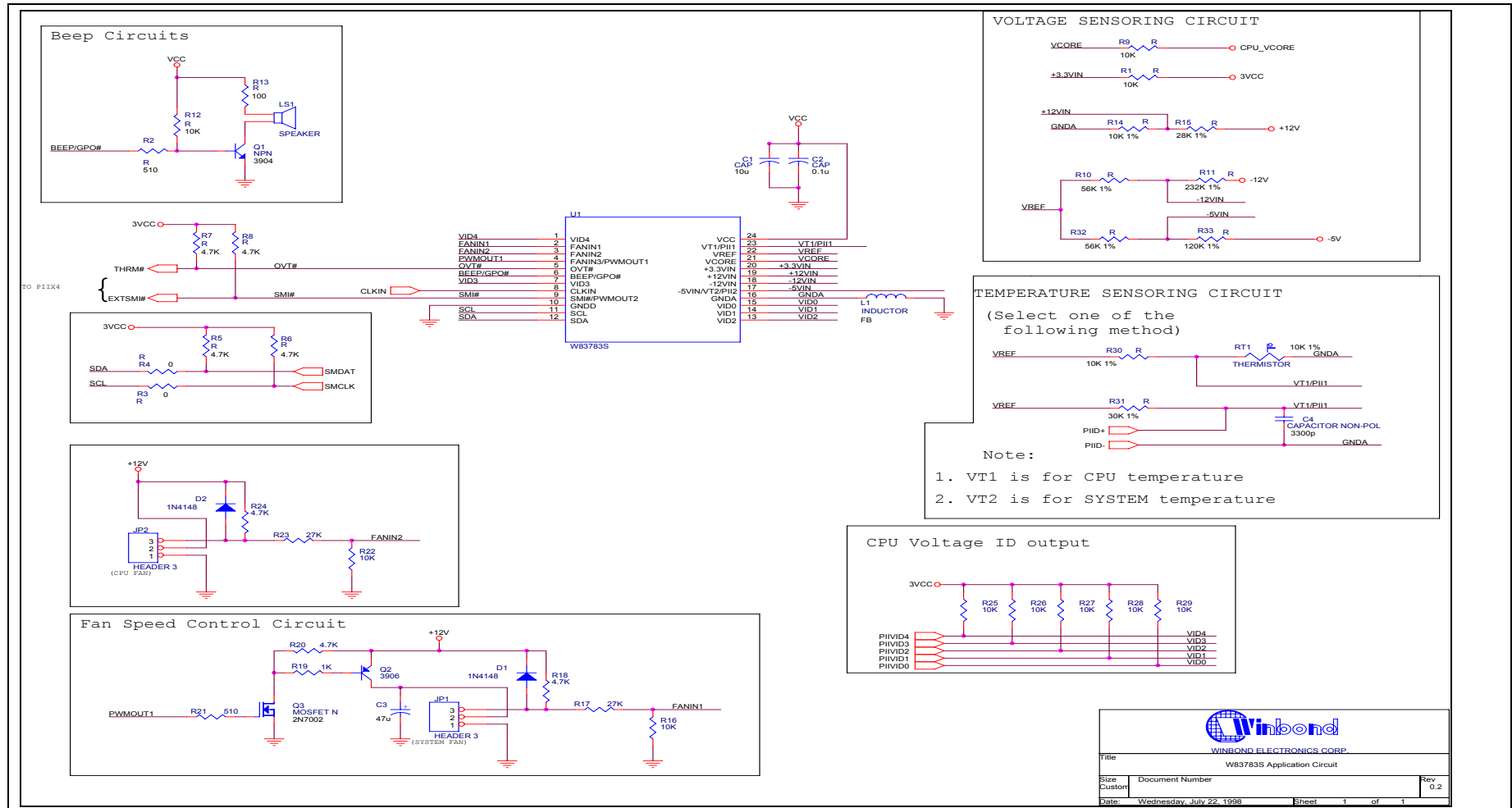

WINBOND ELECTRONICS CORP.	
Title: W83783S Application Circuit	
Size: Custom	Document Number: Rev: 0.2
Date: Wednesday, July 22, 1998	Sheet: 1 of 1



Important Notice

Winbond products are not designed, intended, authorized or warranted for use as components in systems or equipment intended for surgical implantation, atomic energy control instruments, airplane or spaceship instruments, transportation instruments, traffic signal instruments, combustion control instruments, or for other applications intended to support or sustain life. Further more, Winbond products are not intended for applications wherein failure of Winbond products could result or lead to a situation wherein personal injury, death or severe property or environmental damage could occur.

Winbond customers using or selling these products for use in such applications do so at their own risk and agree to fully indemnify Winbond for any damages resulting from such improper use or sales.

*Please note that all data and specifications are subject to change without notice.
All the trademarks of products and companies mentioned in this datasheet belong to their respective owners.*