

Features

- Extremely Low Parasitic Capacitance and Inductance
- Surface Mountable in Microwavable Circuits, No Wirebonds Required
- Rugged HMIC Construction with Polyimide Scratch Protection
- Reliable, Multilayer Metalization with a Diffusion Barrier, 100% Stabilization Bake (300°C, 16 hours)
- Lower Susceptibility to ESD Damage
- RoHS Compliant

Description and Applications

The MA4E2502 SURMOUNT™ Series Diodes are Silicon Low, Medium, and High Barrier Schottky Devices fabricated with the patented Heterolithic Microwave Integrated Circuit (HMIC) process. HMIC circuits consist of Silicon pedestals which form diodes or via conductors embedded in a glass dielectric, which acts as the low dispersion, microstrip transmission medium. The combination of silicon and glass allows HMIC devices to have excellent loss and power dissipation characteristics in a low profile, reliable device.

The Surmount Schottky devices are excellent choices for circuits requiring the small parasitics of a beam lead device coupled with the superior mechanical performance of a chip. The Surmount structure employs very low resistance silicon vias to connect the Schottky contacts to the metalized mounting pads on the bottom surface of the chip. These devices are reliable, repeatable, and a lower cost performance solution to conventional devices. They have lower susceptibility to electrostatic discharge than conventional beam lead Schottky diodes.

The multilayer metallization employed in the fabrication of the Surmount Schottky junctions includes a platinum diffusion barrier, which permits all devices to be subjected to a 16-hour non-operating stabilization bake at 300°C.

The “0502” outline allows for Surface Mount placement and multi-functional polarity orientations.

The MA4E2502 Family of Surmount Schottky diodes are recommended for use in microwave circuits through Ku band frequencies for lower power applications such as mixers, sub-harmonic mixers, detectors, and limiters. The HMIC construction facilitates the direct replacement of more fragile beam lead diodes with the corresponding Surmount diode, which can be connected to a hard or soft substrate circuit with solder.

Case Style 1246

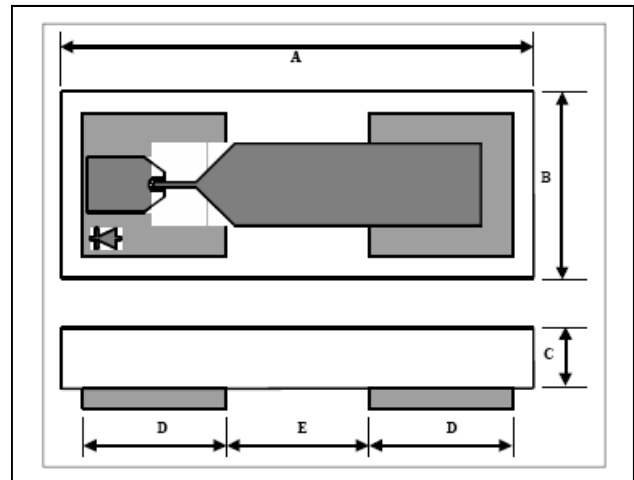

DIM	INCHES		MILLIMETERS	
	MIN.	MAX.	MIN.	MAX.
A	0.0445	0.0465	1.130	1.180
B	0.0169	0.0189	0.430	0.480
C	0.0040	0.0080	0.102	0.203
D Sq.	0.0128	0.0148	0.325	0.375
E	0.0128	0.0148	0.325	0.375

Electrical Specifications @ 25°C

Model Number	Type	Recommended Freq. Range	Vf @ 1 mA (mV)	Vb @ 10 uA (V)	Ct @ 0 V (pF)	Rt Slope Resistance (Vf1-Vf2)/(10.5mA-9.5mA) (Ω)
MA4E2502L	Low Barrier	DC - 18 GHz	330 Max 300 Typ	3 Min 5 Typ	0.12 Max 0.10 Typ	16 Typ 20 Max
MA4E2502M	Medium Barrier	DC - 18 GHz	470 Max 420 Typ	3 Min 5 Typ	0.12 Max 0.10 Typ	12 Typ 18 Max
MA4E2502H	High Barrier	DC - 18 GHz	700 Max 650 Typ	3 Min 5 Typ	0.12 Max 0.10 Typ	11 Typ 15 Max

1. Rt is the dynamic slope resistance where $R_t = R_s + R_j$, where $R_j = 26 / I_{dc}$ (I_{dc} is in mA)

Handling

All semiconductor chips should be handled with care to avoid damage or contamination from perspiration and skin oils. The use of plastic tipped tweezers or vacuum pickups is strongly recommended for individual components. The top surface of the die has a protective polyimide coating to minimize damage.

The rugged construction of these Surmount devices allows the use of standard handling and die attach techniques. It is important to note that industry standard electrostatic discharge (ESD) control is required at all times, due to the sensitive nature of Schottky junctions.

Bulk handling should insure that abrasion and mechanical shock are minimized.

Absolute Maximum Ratings @ 25°C (unless otherwise noted) ¹

Parameter	Absolute Maximum
Operating Temperature	-40°C to +125°C
Storage Temperature	-40°C to +150°C
Junction Temperature	+175°C
Forward Current	20 mA
Reverse Voltage	5 V
RF C.W. Incident Power	+20 dBm
RF & DC Dissipated Power	50 mW
Electrostatic Discharge (ESD) Classification ²	Class 0

Die Bonding

Die attach for these devices is made simple through the use of surface mount die attach technology. Mounting pads are conveniently located on the bottom surface of these devices, and are opposite the active junction. The devices are well suited for high temperature solder attachment onto hard substrates. 80Au/20Sn and Sn63/Pb37 solders are acceptable for usage. Die attach with Electrically Conductive Silver Epoxy is Not Recommended.

For Hard substrates, we recommend utilizing a vacuum tip and force of 60 to 100 grams applied uniformly to the top surface of the device, using a hot gas bonder with equal heat applied across the bottom mounting pads of the device. When soldering to soft substrates, it is recommended to use a lead-tin interface at the circuit board mounting pads. Position the die so that its mounting pads are aligned with the circuit board mounting pads. Reflow the solder paste by applying equal heat to the circuit at both die-mounting pads. The solder joint must Not be made one at a time, creating unequal heat flow and thermal stress. Solder reflow should Not be performed by causing heat to flow through the top surface of the die. Since the HMIC glass is transparent, the edges of the mounting pads can be visually inspected through the die after die attach is completed.

2

2. Human Body Model

ADVANCED: Data Sheets contain information regarding a product M/A-COM Technology Solutions is considering for development. Performance is based on target specifications, simulated results, and/or prototype measurements. Commitment to develop is not guaranteed.

PRELIMINARY: Data Sheets contain information regarding a product M/A-COM Technology Solutions has under development. Performance is based on engineering tests. Specifications are typical. Mechanical outline has been fixed. Engineering samples and/or test data may be available. Commitment to produce in volume is not guaranteed.

• **North America** Tel: 800.366.2266 • **Europe** Tel: +353.21.244.6400
 • **India** Tel: +91.80.43537383 • **China** Tel: +86.21.2407.1588
 Visit www.macomtech.com for additional data sheets and product information.

M/A-COM Technology Solutions Inc. and its affiliates reserve the right to make changes to the product(s) or information contained herein without notice.

Applications Section

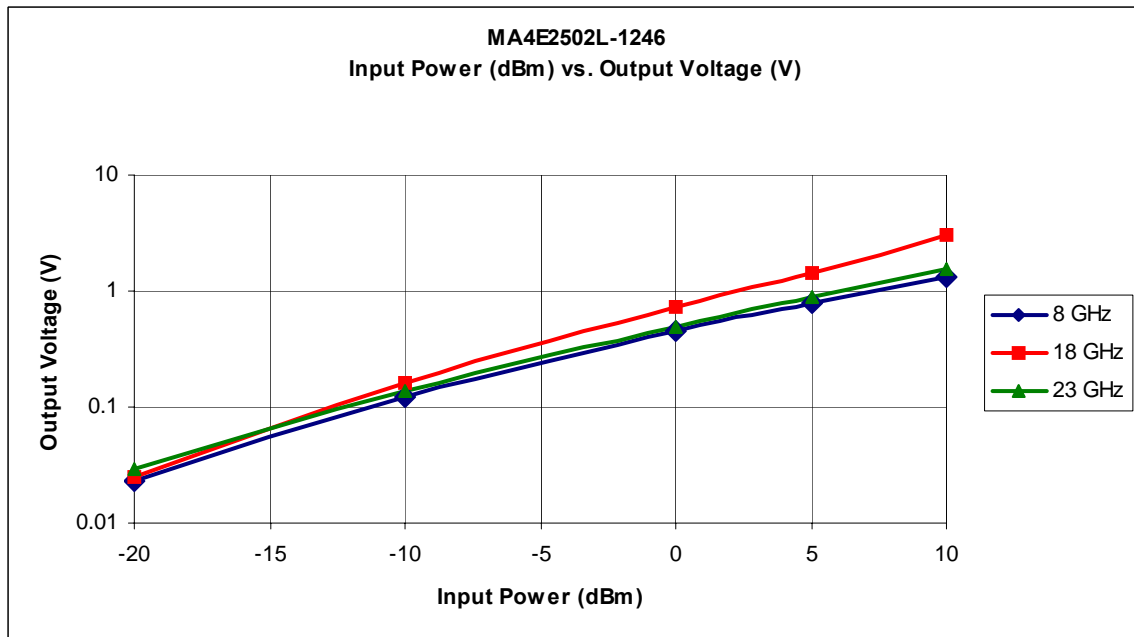
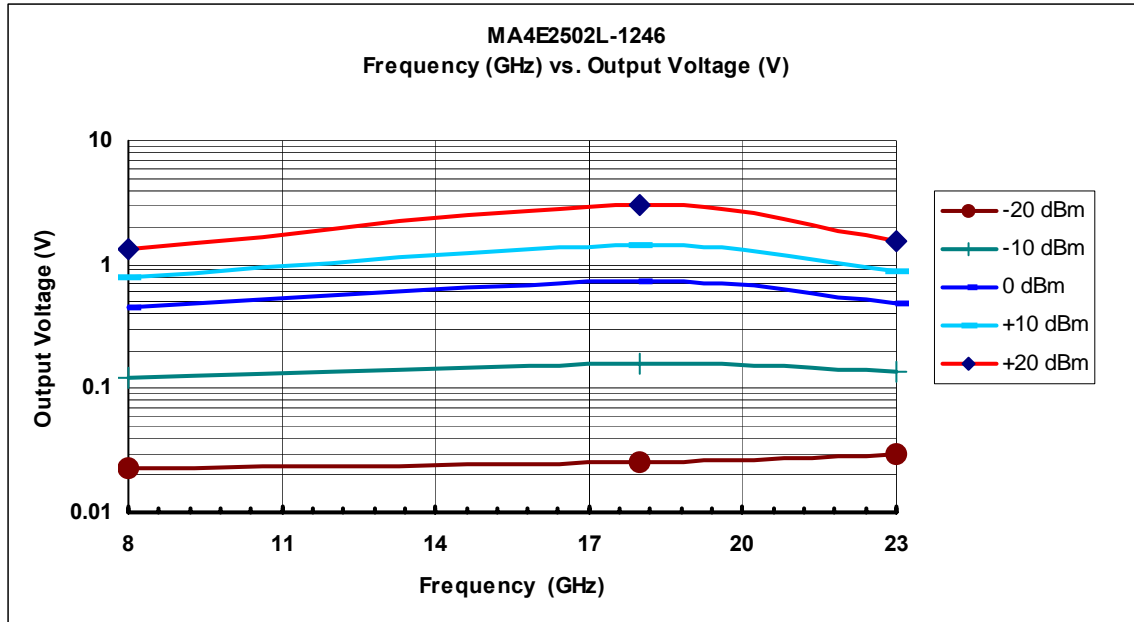

The MA4E2502L-1246 chip was evaluated in a detector circuit in which the Schottky diode terminates a 50 ohm transmission line on a duroid substrate. The chip was attached to the terminal of a 3.5mm connector and the output voltage was measured through a bias tee on a voltmeter. Matching was not attempted.

MA4E2502L Low Barrier SPICE PARAMETERS

Is (nA)	Rs (Ω)	N	Cj0 (pF)	M	Ik (mA)	Cjpar (pF)	Vj (V)	FC	BV (V)	IBV (mA)
26	12.8	1.20	1.0 E-2	0.5	14	9.0 E-2	8.0 E-2	0.5	5.0	1.0 E-2

MA4E2502M Medium Barrier SPICE PARAMETERS

Is (mA)	Rs (Ω)	N	Cj0 (pF)	M	Ik (mA)	Cjpar (pF)	Vj (V)	FC	BV (V)	IBV (mA)
5 E-1	9.6	1.20	1.0 E-02	0.5	10	9.0 E-2	8.0 E-2	0.5	5.0	1.0 E-2

MA4E2502H High Barrier SPICE PARAMETERS

Is (mA)	Rs (Ω)	N	Cj0 (pF)	M	Ik (mA)	Cjpar (pF)	Vj (V)	FC	BV (V)	IBV (mA)
5.7 E-1	6.5	1.20	1.0 E-02	0.5	4	9.0 E-2	8.0 E-2	0.5	5.0	1.0 E-2

Circuit Mounting Dimensions (Inches)

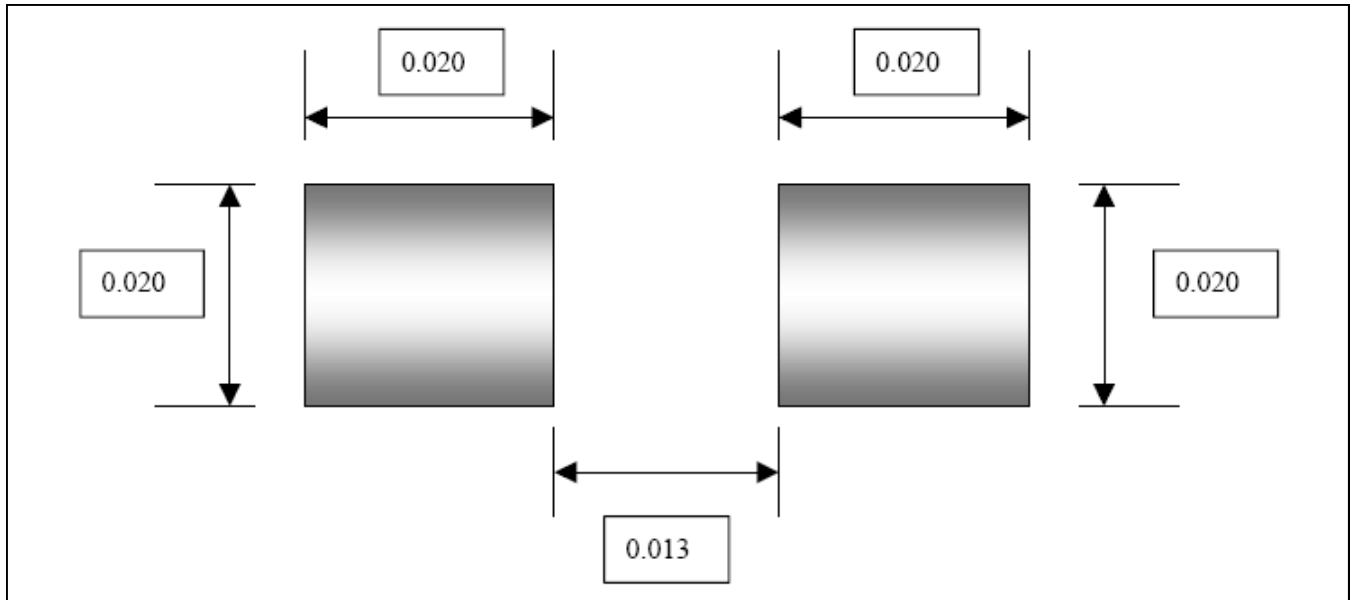

MA4E2502 Series

SURMOUNT™ Low, Medium, and High Barrier Silicon Schottky Diodes

M/A-COM Products
Rev. V9

Ordering Information

Part Number	Package	Standard Quantity
MA4E2502L-1246W	Wafer on Frame	*
MA4E2502L-1246	Die in Carrier	100
MADS-002502-1246LP	Pocket Tape on Reel	3000
MA4E2502M-1246W	Wafer on Frame	*
MA4E2502M-1246	Die in Carrier	100
MADS-002502-1246MP	Pocket Tape on Reel	3000
MA4E2502H-1246W	Wafer on Frame	*
MA4E2502H-1246	Die in Carrier	100
MADS-002502-1246HP	Pocket Tape on Reel	3000

* Call factory for standard quantities for full wafers on frames.

MA4E2502 Diode Schematic

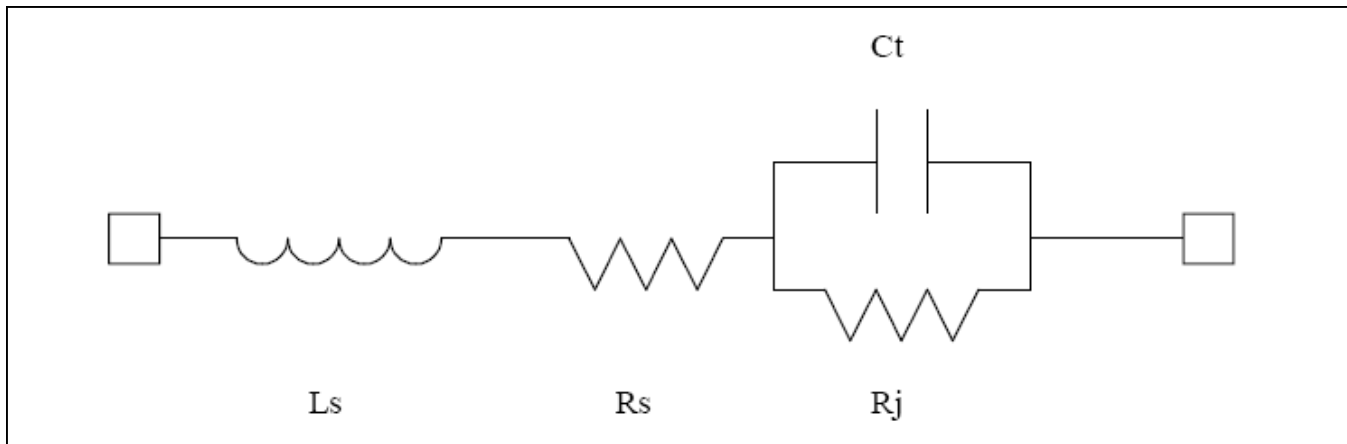

Schematic Values

Model Number	L_s (nH)	R_s (Ω)	R_j (Ω)	C_t (pF)
MA4E2502L	0.45	12.8	26 / I _{dc} (mA)	0.10
MA4E2502M	0.45	9.6	26 / I _{dc} (mA)	0.10
MA4E2502H	0.45	6.5	26 / I _{dc} (mA)	0.10

ADVANCED: Data Sheets contain information regarding a product M/A-COM Technology Solutions is considering for development. Performance is based on target specifications, simulated results, and/or prototype measurements. Commitment to develop is not guaranteed.

PRELIMINARY: Data Sheets contain information regarding a product M/A-COM Technology Solutions has under development. Performance is based on engineering tests. Specifications are typical. Mechanical outline has been fixed. Engineering samples and/or test data may be available. Commitment to produce in volume is not guaranteed.

• **North America** Tel: 800.366.2266 • **Europe** Tel: +353.21.244.6400
 • **India** Tel: +91.80.43537383 • **China** Tel: +86.21.2407.1588
 Visit www.macomtech.com for additional data sheets and product information.

M/A-COM Technology Solutions Inc. and its affiliates reserve the right to make changes to the product(s) or information contained herein without notice.