



MMBT4401

NPN GENERAL PURPOSE SWITCHING TRANSISTOR

VOLTAGE 40 Volts **POWER** 225 mWatts

SOT-23 Unit: inch (mm)

FEATURES

- NPN epitaxial silicon, planar design
- Collector-emitter voltage $V_{CE} = 40V$
- Collector current $I_C = 600mA$
- In compliance with EU RoHS 2002/95/EC directives

MECHANICAL DATA

- Case: SOT-23, Plastic
- Terminals: Solderable per MIL-STD-750, Method 2026
- Approx. Weight: 0.008 gram
- Marking: M4A

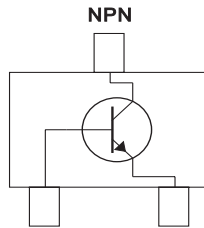
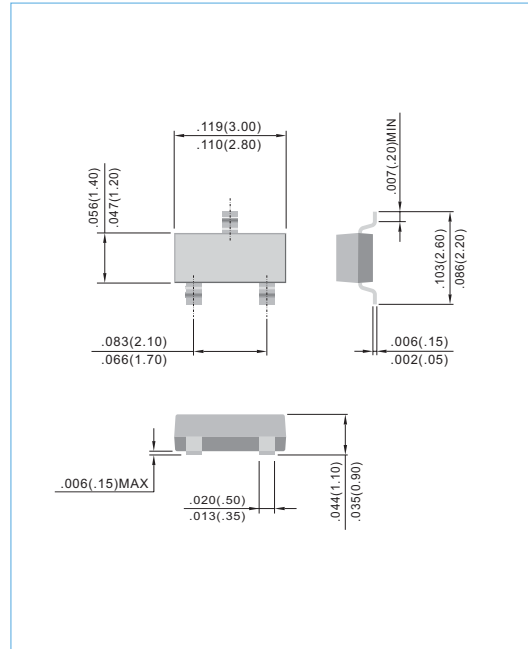

Fig.34

ABSOLUTE RATINGS

PARAMETER	Symbol	Value	Units
Collector - Emitter Voltage	V_{CEO}	40	V
Collector - Base Voltage	V_{CBO}	60	V
Emitter - Base Voltage	V_{EBO}	6.0	V
Collector Current - Continuous	I_C	600	mA

THERMAL CHARACTERISTICS

PARAMETER	Symbol	Value	Units
Max Power Dissipation (Note 1)	P_{TOT}	225	mW
Thermal Resistance , Junction to Ambient	$R_{\theta A}$	556	$^{\circ}C/W$
Junction Temperature	T_J	-55 to 150	$^{\circ}C$
Storage Temperature	T_{STG}	-55 to 150	$^{\circ}C$

Note 1: Transistor mounted on FR-5 board 1.0 x 0.75 x 0.062 in.



MMBT4401

ELECTRICAL CHARACTERISTICS

PARAMETER	Symbol	Test Condition	MIN.	TYP.	MAX.	Units
Collector - Emitter Breakdown Voltage	$V_{(BR)CEO}$	$I_C=1.0mA, I_B=0$	40	-	-	V
Collector - Base Breakdown Voltage	$V_{(BR)CBO}$	$I_C=100\mu A, I_E=0$	60	-	-	V
Emitter - Base Breakdown Voltage	$V_{(BR)EBO}$	$I_E=100\mu A, I_C=0$	6.0	-	-	V
Base Cutoff Current	I_{BL}	$V_{CE}=35V, V_{EB}=0.4V$	-	-	100	nA
Collector Cutoff Current	I_{CEX}	$V_{CE}=35V, V_{EB}=0.4V$	-	-	100	nA
DC Current Gain (Note 2)	h_{FE}	$I_C=0.1mA, V_{CE}=1.0V$	20	-	-	-
		$I_C=1.0mA, V_{CE}=1.0V$	40	-	-	
		$I_C=10mA, V_{CE}=1.0V$	80	-	-	
		$I_C=150mA, V_{CE}=1.0V$	100	-	300	
		$I_C=500mA, V_{CE}=2.0V$	40	-	-	
Collector - Emitter Saturation Voltage (Note 2)	$V_{CE(SAT)}$	$I_C=150mA, I_B=15mA$ $I_C=500mA, I_B=50mA$	-	-	0.40 0.75	V
Base - Emitter Saturation Voltage (Note 2)	$V_{BE(SAT)}$	$I_C=150mA, I_B=15mA$ $I_C=500mA, I_B=50mA$	0.75 -	- -	0.95 1.20	V
Collector - Base Capacitance	C_{CBO}	$V_{CB}=5V, I_E=0, f=1MHz$	-	-	6.5	pF
Emitter - Base Capacitance	C_{EBO}	$V_{CB}=0.5V, I_C=0, f=1MHz$	-	-	30	pF
Current Gain - Bandwidth Product	F_T	$V_{CE}=10V, I_C=20mA, f=100MHz$	250	-	-	MHz
Delay Time	t_d	$V_{CC}=30V, V_{BE}=2.0V,$ $I_C=150mA, I_{B1}=15mA$	-	-	15	ns
Rise Time	t_r	$V_{CC}=30V, V_{BE}=2.0V,$ $I_C=150mA, I_{B1}=15mA$	-	-	20	ns
Storage Time	t_s	$V_{CC}=30V, I_C=150mA$ $I_{B1}=I_{B2}=15mA$	-	-	225	ns
Fall Time	t_f	$V_{CC}=30V, I_C=150mA$ $I_{B1}=I_{B2}=15mA$	-	-	30	ns



MMBT4401

MOUNTING PAD LAYOUT

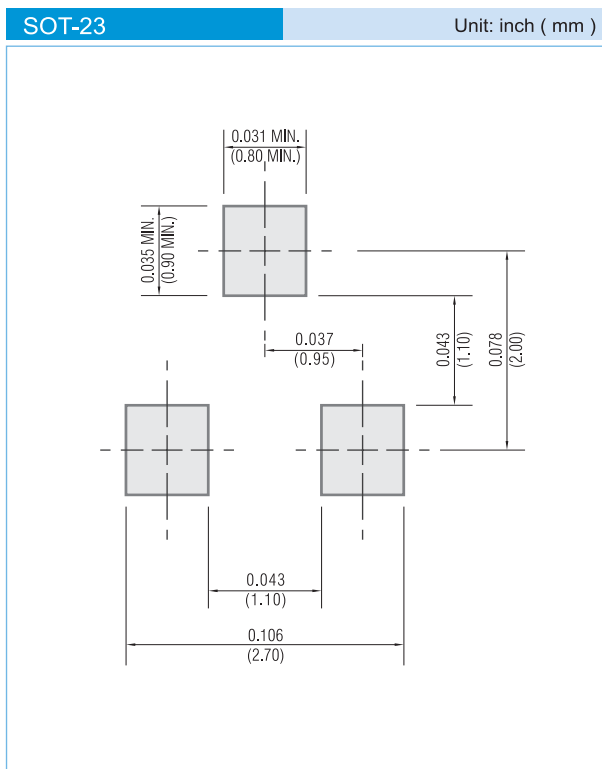

ORDER INFORMATION

- Packing information
 - T/R - 12K per 13" plastic Reel
 - T/R - 3K per 7" plastic Reel

LEGAL STATEMENT

Copyright PanJit International, Inc 2007

The information presented in this document is believed to be accurate and reliable. The specifications and information herein are subject to change without notice. Pan Jit makes no warranty, representation or guarantee regarding the suitability of its products for any particular purpose. Pan Jit products are not authorized for use in life support devices or systems. Pan Jit does not convey any license under its patent rights or rights of others.