

R2A20118ASP

R03DS0002EJ0100

Rev.1.00

Jul 14, 2010

Critical Conduction Mode Interleaved PFC Control IC

Description

The R2A20118A controls a boost converter to provide an active power factor correction.

The R2A20118A is based on R2A20117, and additional functions are OVP2 and Brownout.

The R2A20118A adopts critical conduction mode for power factor correction and realizes high efficiency and a low switching noise by zero current switching.

Interleaving function improves ripple current on input or output capacitor by 180 degrees phase shift.

The feedback loop short detection, two modes overvoltage protection and OVP2, overcurrent protection, overcurrent timer latch protection, and ZCD open detection are built in the R2A20118A, and can constitute a power supply system of high reliability with few external parts.

Features

- Absolute Maximum Ratings
 - Supply voltage V_{cc} : 24 V
 - Operating junction temperature T_{jopr} : -40 to +150°C
- Electrical Characteristics
 - VREF output voltage V_{REF} : 5.0 V \pm 1.5%
 - UVLO operation start voltage V_{uvlh} : 10.5 V \pm 0.7 V
 - UVLO operation shutdown voltage V_{uvll} : 9.3 V \pm 0.5 V
 - UVLO hysteresis voltage H_{ysuvl} : 1.2 V \pm 0.5 V
- Functions
 - Boost converter control with critical conduction mode
 - Interleaving control
 - Brownout function
 - Two mode overvoltage protection and OVP2
 - Mode1: Dynamic OVP corresponding to a voltage rise by dynamic load change
 - Mode2: Static OVP corresponding to overvoltage in stable.
 - OVP2: OVP2 sense the PFC output voltage by independenced pin.
 - Feedback loop short detection
 - Slave ZCD signal open detection
 - RAMP charge current selectable function
 - Master and Slave independenced overcurrent protection
 - Overcurrent timer latch protection at abnormal operation
 - 280 μ s restart timer
 - Soft start function for the reference voltage of Error Amp
 - Package: Pb-free SOP-20

Ordering Information

Part No.	Package Name	Package Code	Package Abbreviation	Taping Abbreviation (Quantity)
R2A20118ASPW0	FP-20DAV	PRSP0020DD-B	SP	W (2,000 pcs/reel)

Pin Arrangement

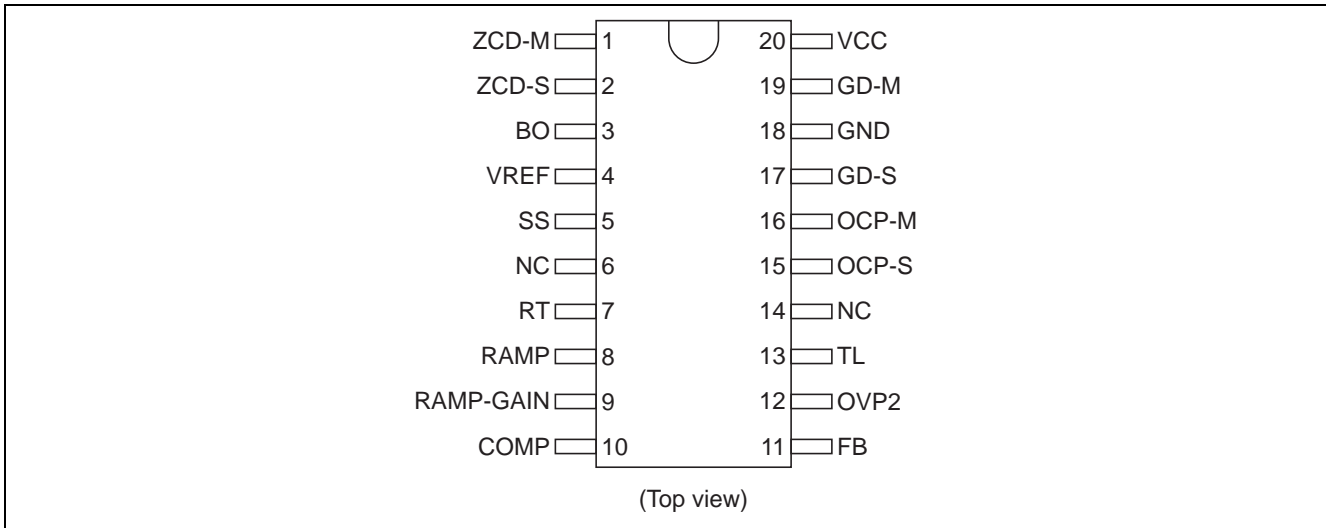

Pin Functions

Pin No.	Pin Name	Input/Output	Function
1	ZCD-M	Input	Master converter zero current detection input terminal
2	ZCD-S	Input	Slave converter zero current detection input terminal
3	BO	Input	Brownout input terminal
4	VREF	Output	Reference voltage output terminal
5	SS	Output	Soft start time setting terminal
6	NC	—	Open terminal
7	RT	Input/Output	Oscillator frequency setting terminal
8	RAMP	Input/Output	Ramp waveform setting terminal
9	RAMP-GAIN	Input	RAMP charge current selection terminal
10	COMP	Output	Error amplifier output terminal
11	FB	Input	Error amplifier input terminal
12	OVP2	Input	Over voltage detection terminal
13	TL	Output	Timer latch time setting terminal
14	NC	—	Open terminal
15	OCP-S	Input	Slave converter overcurrent detection terminal
16	OCP-M	Input	Master converter overcurrent detection terminal
17	GD-S	Output	Slave converter Power MOSFET drive terminal
18	GND	—	Ground
19	GD-M	Output	Master converter Power MOSFET drive terminal
20	VCC	Input	Supply voltage terminal

Block Diagram

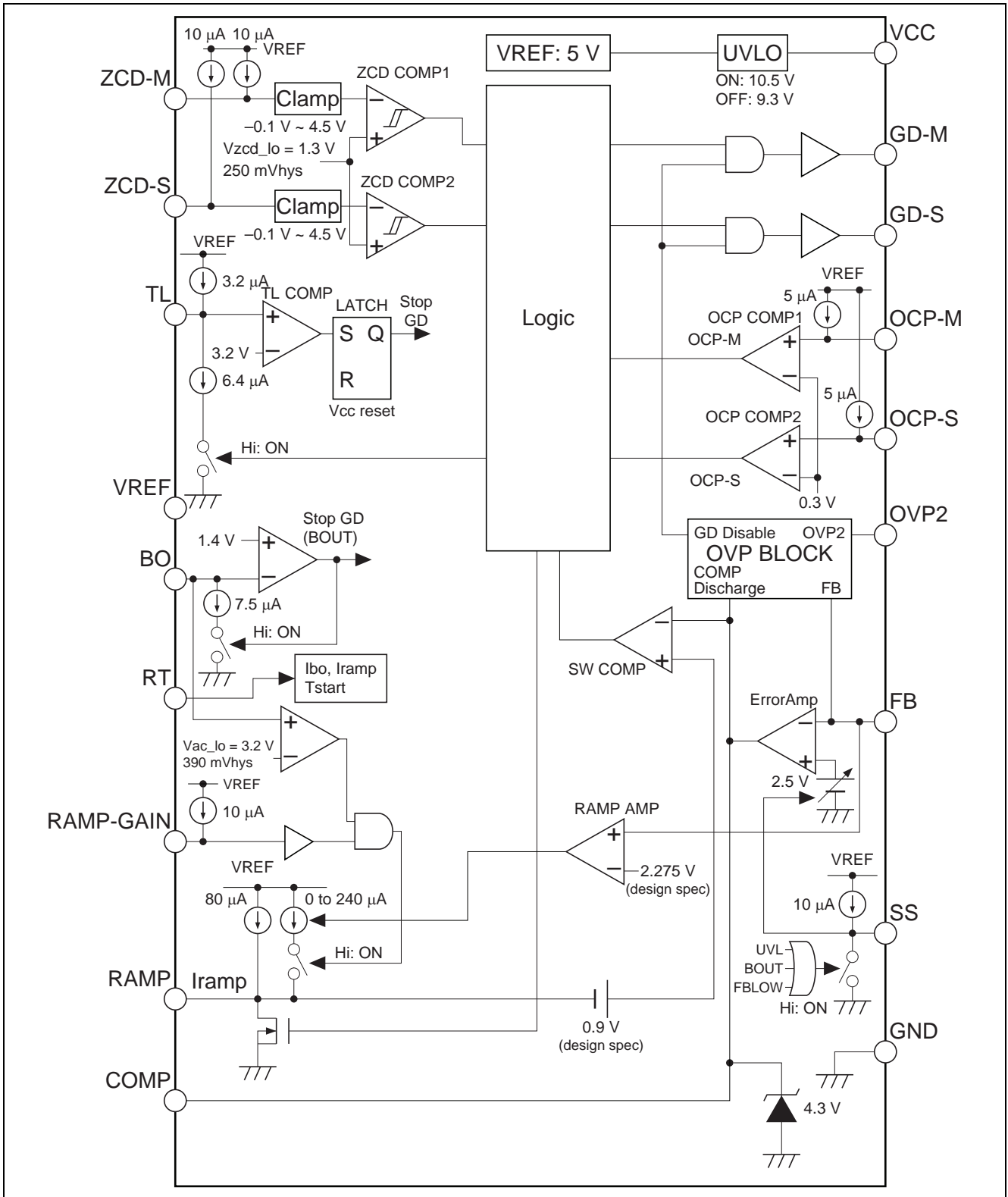

Absolute Maximum Ratings

(Ta = 25°C)

Item	Symbol	Ratings	Unit	Notes
Supply voltage	VCC	-0.3 to 24	V	
GD terminal peak current	Ipk-gd	-300 +1200	mA	3
GD terminal DC current	I _{dc-gd}	-15 +60	mA	
ZCD terminal current	I _{zcd}	+3 -3	mA	
BO terminal current	I _{bom}	200	μA	
RT terminal current	I _{rt}	-200	μA	
Vref terminal current	I _{ref}	-5	mA	
Vref terminal capacitor	C _{ref min}	1000	pF	
	C _{ref max}	1	μF	
COMP terminal current	I _{comp}	±1	mA	
Terminal voltage	V _{t-group1}	-0.3 to V _{cc}	V	4
	V _{t-group2}	-0.3 to V _{ref}	V	5
Vref terminal voltage	V _{t-ref}	-0.3 to V _{ref} + 0.3	V	
OCP terminal voltage	V _{t-ocp}	*-1 to V _{ref}	V	6
Power dissipation	P _t	1	W	7
Operating junction temperature	T _{j-opr}	-40 to +150	°C	
Storage temperature	T _{stg}	-55 to +150	°C	

- Notes:
- Rated voltages are with reference to the GND terminal.
 - For rated currents, inflow to the IC is indicated by (+), and outflow by (-).
 - Shows the transient current when driving a capacitive load.
 - This is the rated voltage for the following pins:
NC
 - This is the rated voltage for the following pins:
FB, OVP2, RT, TL, RAMP-GAIN, SS, RAMP
 - Minus value is peak voltage. Do not impress the DC voltage of the minus.
 - $\theta_{ja} = 120^{\circ}\text{C/W}$
This value is a thing mounting on 40 × 40 (thickness: 1.6 mm) [mm²],
a glass epoxy board of wiring density 10%.

Electrical Characteristics

(Ta = 25°C, VCC = 12 V, RT = 33 kΩ, BO = 5 V, OCP = TL = OVP2 = GND, CRAMP = 820 pF, FB = COMP, RAMP-GAIN = OPEN)

Item		Symbol	Min	Typ	Max	Unit	Test Conditions
Supply	UVLO turn-on threshold	Vuvlh	9.8	10.5	11.2	V	
	UVLO turn-off threshold	Vuvll	8.8	9.3	9.8	V	
	UVLO hysteresis	Hysuvl	0.7	1.2	1.7	V	
	Standby current	Istby	—	85	170	μA	VCC = 8.9 V
	Operating current	Icc	—	4.2	6.3	mA	FB: Open
Brownout	BO threshold voltage	Vbo	1.33	1.40	1.47	V	
	BO pin hysteresis current	Ibo	6.7	7.5	8.3	μA	BO = 1 V
VREF	Output voltage	Vref	4.925	5.00	5.075	V	Isource = -1 mA
	Line regulation	Vref-line	—	5	20	mV	Isource = -1 mA Vcc = 10 V to 24 V
	Load regulation	Vref-load	—	5	20	mV	Isource = -1 mA to -5 mA
	Temperature stability	dVref	—	±80	—	ppm/°C	Ta = -40 to 125°C *1
Error amplifier	Feedback voltage	Vfb	2.452	2.49	2.528	V	FB-COMP short
	Input bias current	Ifb	-0.5	-0.3	-0.1	μA	Measured pin: FB FB = 3 V *1
	Open loop gain	Av	—	60	—	dB	*1
	Upper clamp voltage	Vclamp-comp	4.0	4.3	—	V	FB = 2.0 V COMP: Open
	Low voltage	Vl-comp	—	0.1	0.3	V	FB = 3.0 V COMP: Open
	Source current	Isrc-comp	—	-120	—	μA	FB = 1.5 V COMP = 2.5 V
	Sink current	Isnk-comp	—	330	—	μA	FB = 3.5 V COMP = 2.5 V
	Transconductance	gm	120	200	290	μs	FB = 2.45V ↔ 2.55 V COMP = 2.5 V
RAMP	RAMP charge current 1	Ic-ramp1	72	80	88	μA	RAMP = 0 V to 3 V RAMP-GAIN = GND
	RAMP charge current 2	Ic-ramp2	288	320	352	μA	RAMP = 0 V to 3 V
	RAMP discharge current	Id-ramp	7	15	29	mA	FB = 3 V RAMP = 1 V
	Low voltage	Vl-ramp	—	17	200	mV	FB = 3 V I _{sink} = 100 μA
RAMP gain control	Threshold voltage	Vth-ramp_gain	1.5	2.5	3.5	V	Measured pin RAMP-GAIN
	Input bias current	I _{ramp_gain}	-14	-10	-6	μA	RAMP-GAIN = 3.5 V
	AC detect low threshold voltage	Vac-lo	2.9	3.2	3.5	V	Measured pin BO
	AC detect hysteresis	Hys-ac	350	390	430	mV	Measured pin BO

Note: *1 Design spec.

Electrical Characteristics (cont.)

(Ta = 25°C, VCC = 12 V, RT = 33 kΩ, BO = 5 V, OCP = TL = OVP2 = GND, CRAMP = 820 pF, FB = COMP, RAMP-GAIN = OPEN)

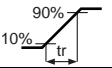
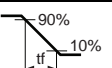
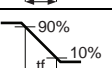
Item		Symbol	Min	Typ	Max	Unit	Test Conditions
Slave control	Phase delay	Phase	160	180	200	deg	*1, *2
	On time ratio	Ton-ratio	0	—	5	%	*1, *2
Gate drive	Master gate drive rise time	tr-gdm	—	20	100	ns	CL = 100 pF 
	Slave gate drive rise time	tr-gds	—	20	100	ns	CL = 100 pF 
	Master gate drive fall time	tf-gdm	—	5	30	ns	CL = 100 pF 
	Slave gate drive fall time	tf-gds	—	5	30	ns	CL = 100 pF 
	Master gate drive low voltage	Vol1-gdm	—	0.02	0.1	V	Isink = 2 mA
		Vol2-gdm	—	0.01	0.2	V	Isink = 1 mA, VCC = 5 V
	Master gate drive high voltage	Voh-gdm	11.5	11.9	—	V	Isource = -2 mA *1
	Slave gate drive low voltage	Vol1-gds	—	0.02	0.1	V	Isink = 2 mA
		Vol2-gds	—	0.01	0.2	V	Isink = 1 mA, VCC = 5 V
Slave gate drive high voltage	Voh-gds	11.5	11.9	—	V	Isource = -2 mA *1	
Over current protection	OCP threshold voltage	Vocp	0.27	0.30	0.33	V	
Over voltage protection	Dynamic OVP threshold voltage	Vdovp	VFB× 1.035	VFB× 1.050	VFB× 1.065	V	COMP = 2.5 V
	Static OVP threshold voltage	Vsovp1	VFB× 1.075	VFB× 1.090	VFB× 1.105	V	COMP = 2.5 V
	Static OVP hysteresis	Hys-sovp1	50	100	150	mV	COMP = 2.5 V
	FB Low detect threshold voltage	Vfblow	0.45	0.50	0.55	V	COMP = 2.5 V
	FB Low detect hysteresis	Hysfblow	0.16	0.20	0.24	V	COMP = 2.5 V
	OVP2 threshold voltage	Vovp2	2.670	2.725	2.780	V	Measured pin: OVP2
	OVP2 pin input bias current	lovp2	-0.5	-0.3	-0.1	μA	Measured pin: OVP2 OVP2 = 3 V *1

Notes: *1 Design spec.

*2

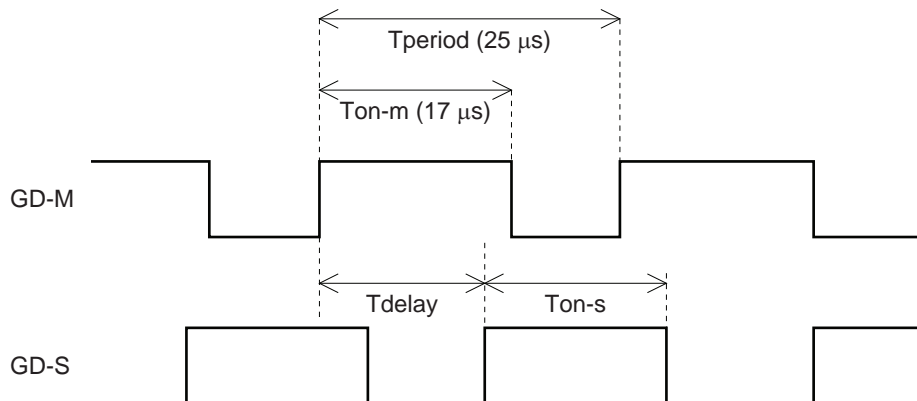

$$\text{Phase} = \frac{T_{\text{delay}}}{T_{\text{period}}} \times 360 \text{ [deg]}$$

$$\text{Ton-ratio} = \left(1 - \frac{T_{\text{on-s}}}{T_{\text{on-m}}}\right) \times 100 \text{ [%]}$$

Electrical Characteristics (cont.)

($T_a = 25^\circ\text{C}$, $V_{CC} = 12\text{ V}$, $R_T = 33\text{ k}\Omega$, $BO = 5\text{ V}$, $OCP = TL = OVP2 = GND$, $CRAMP = 820\text{ pF}$, $FB = COMP$, $RAMP-GAIN = OPEN$)

Item		Symbol	Min	Typ	Max	Unit	Test Conditions
Zero current detector	Upper clamp voltage	Vzcdh	4.0	4.5	5.0	V	I _{source} = -3 mA
	Lower clamp voltage	Vzcdl	-0.5	-0.1	0.4	V	I _{sink} = 3 mA
	ZCD low threshold voltage	Vzcd-lo	0.9	1.3	1.6	V	* ¹
	ZCD hysteresis	Hyszcd	130	250	360	mV	* ¹
	Input bias current	Izcd	-14	-10	-6	μA	1.2 V < Vzcd < 2.5 V
ZCD open detector	Slave ZCD open detect delay time	tzcds	—	100	—	ms	ZCD-S: Open Gate drive 10 kHz * ¹
Soft start	Charge current	Ic-ss	-14	-10	-6	μA	SS = 2 V
Timer latch for overcurrent	Charge current	Ic-tl	-4.8	-3.2	-1.2	μA	TL = 2 V OCP-M = 0.5 V
	Discharge current	Id-tl	1.2	3.2	4.8	μA	TL = 2 V
	Threshold voltage	Vtl	2.88	3.2	3.52	V	
Restart	Restart time delay	Tstart	210	280	350	μs	ZCD-M = 10 k Ω ZCD-S = 10 k Ω * ²

Notes: *¹ Design spec.

*²

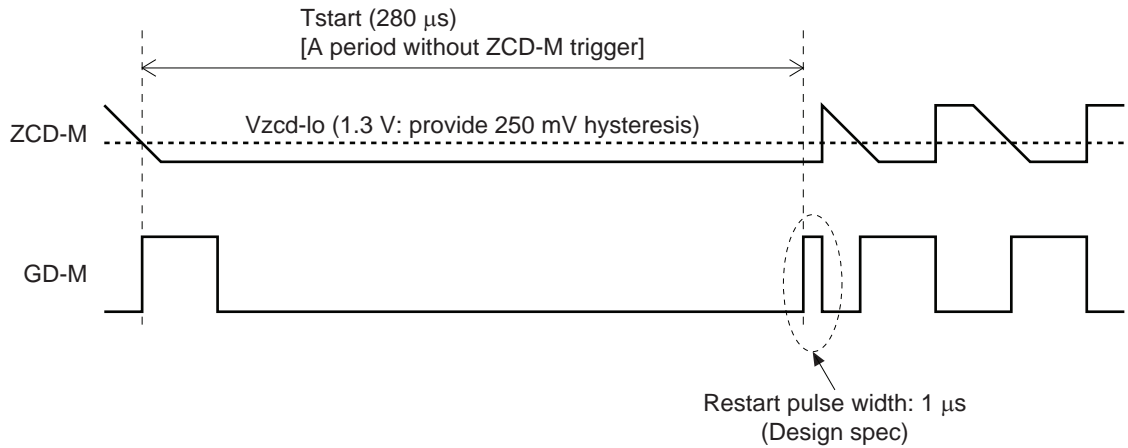

System Diagram

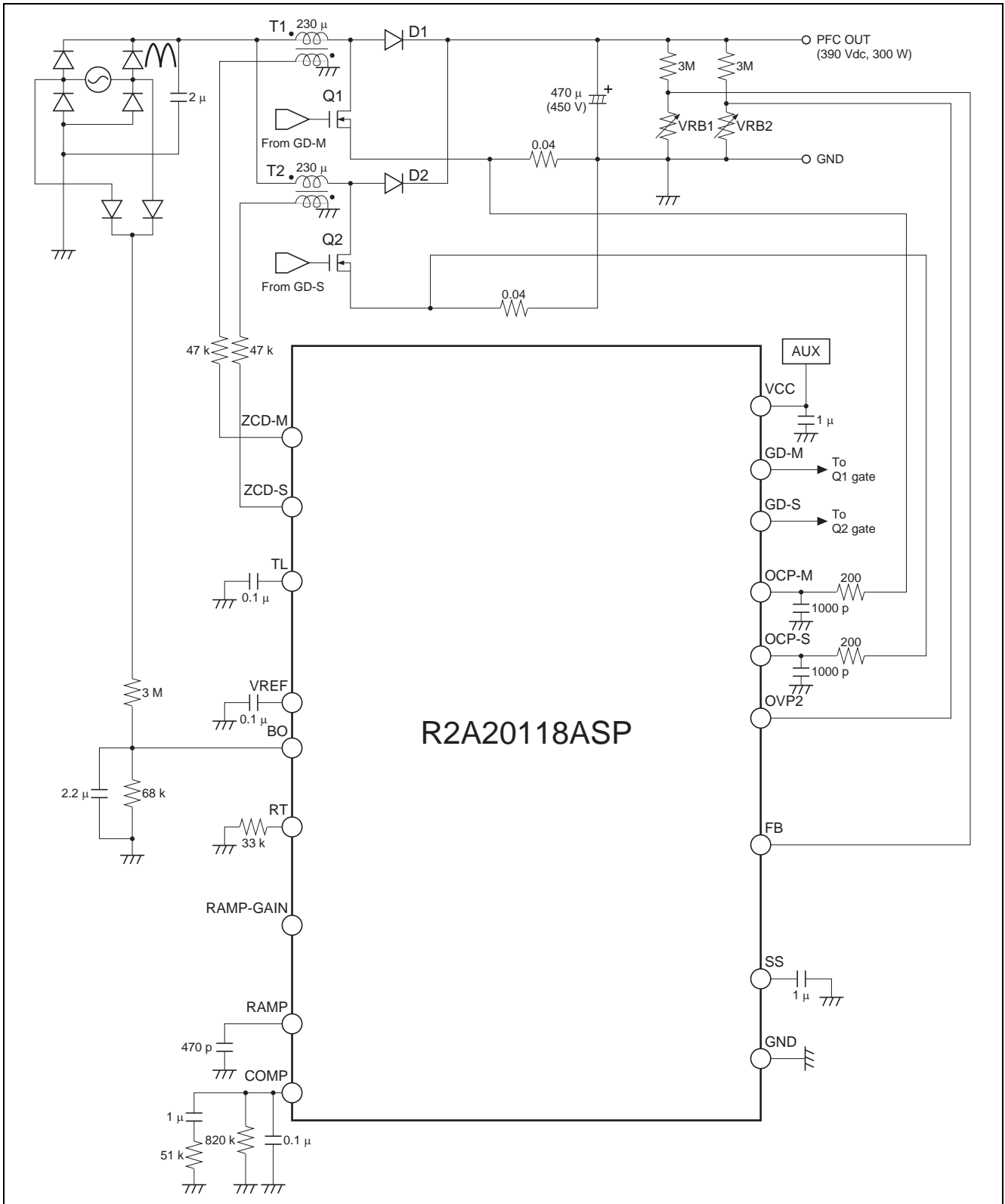

Package Dimensions

JEITA Package Code	RENESAS Code	Previous Code	MASS[Typ.]
P-SOP20-5.5x12.6-1.27	PRSP0020DD-B	FP-20DAV	0.31g

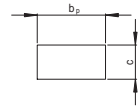
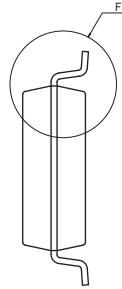
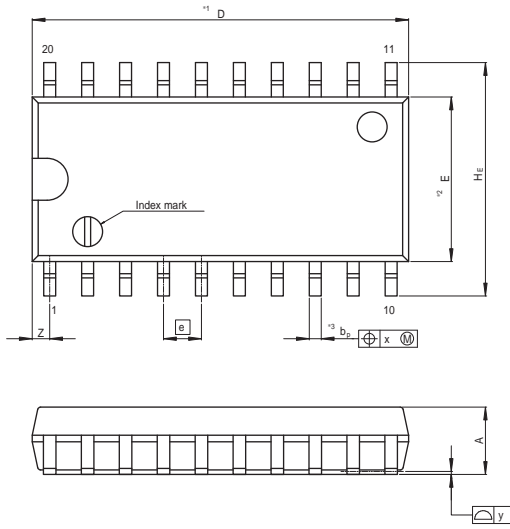

Terminal cross section
(Ni/Pd/Au plating)

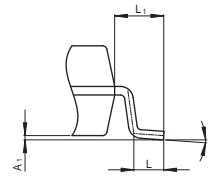

Detail F

NOTE)
1. DIMENSIONS*1 (Nom)*AND*2*
DO NOT INCLUDE MOLD FLASH.
2. DIMENSION*3*DOES NOT
INCLUDE TRIM OFFSET.

Reference Symbol	Dimension in Millimeters		
	Min	Nom	Max
D	—	12.60	13.0
E	—	5.50	—
A ₂	—	—	—
A ₁	0.00	0.10	0.20
A	—	—	2.20
b _P	0.34	0.40	0.46
b ₁	—	—	—
c	0.15	0.20	0.25
c ₁	—	—	—
θ	0°	—	8°
HE	7.50	7.80	8.00
Ⓜ	—	1.27	—
x	—	—	0.12
y	—	—	0.15
Z	—	—	0.80
L	0.50	0.70	0.90
L ₁	—	1.15	—

Notice

- All information included in this document is current as of the date this document is issued. Such information, however, is subject to change without any prior notice. Before purchasing or using any Renesas Electronics products listed herein, please confirm the latest product information with a Renesas Electronics sales office. Also, please pay regular and careful attention to additional and different information to be disclosed by Renesas Electronics such as that disclosed through our website.
- Renesas Electronics does not assume any liability for infringement of patents, copyrights, or other intellectual property rights of third parties by or arising from the use of Renesas Electronics products or technical information described in this document. No license, express, implied or otherwise, is granted hereby under any patents, copyrights or other intellectual property rights of Renesas Electronics or others.
- You should not alter, modify, copy, or otherwise misappropriate any Renesas Electronics product, whether in whole or in part.
- Descriptions of circuits, software and other related information in this document are provided only to illustrate the operation of semiconductor products and application examples. You are fully responsible for the incorporation of these circuits, software, and information in the design of your equipment. Renesas Electronics assumes no responsibility for any losses incurred by you or third parties arising from the use of these circuits, software, or information.
- When exporting the products or technology described in this document, you should comply with the applicable export control laws and regulations and follow the procedures required by such laws and regulations. You should not use Renesas Electronics products or the technology described in this document for any purpose relating to military applications or use by the military, including but not limited to the development of weapons of mass destruction. Renesas Electronics products and technology may not be used for or incorporated into any products or systems whose manufacture, use, or sale is prohibited under any applicable domestic or foreign laws or regulations.
- Renesas Electronics has used reasonable care in preparing the information included in this document, but Renesas Electronics does not warrant that such information is error free. Renesas Electronics assumes no liability whatsoever for any damages incurred by you resulting from errors in or omissions from the information included herein.
- Renesas Electronics products are classified according to the following three quality grades: "Standard", "High Quality", and "Specific". The recommended applications for each Renesas Electronics product depends on the product's quality grade, as indicated below. You must check the quality grade of each Renesas Electronics product before using it in a particular application. You may not use any Renesas Electronics product for any application categorized as "Specific" without the prior written consent of Renesas Electronics. Further, you may not use any Renesas Electronics product for any application for which it is not intended without the prior written consent of Renesas Electronics. Renesas Electronics shall not be in any way liable for any damages or losses incurred by you or third parties arising from the use of any Renesas Electronics product for an application categorized as "Specific" or for which the product is not intended where you have failed to obtain the prior written consent of Renesas Electronics. The quality grade of each Renesas Electronics product is "Standard" unless otherwise expressly specified in a Renesas Electronics data sheets or data books, etc.
"Standard": Computers; office equipment; communications equipment; test and measurement equipment; audio and visual equipment; home electronic appliances; machine tools; personal electronic equipment; and industrial robots.
"High Quality": Transportation equipment (automobiles, trains, ships, etc.); traffic control systems; anti-disaster systems; anti-crime systems; safety equipment; and medical equipment not specifically designed for life support.
"Specific": Aircraft; aerospace equipment; submersible repeaters; nuclear reactor control systems; medical equipment or systems for life support (e.g. artificial life support devices or systems), surgical implantations, or healthcare intervention (e.g. excision, etc.), and any other applications or purposes that pose a direct threat to human life.
- You should use the Renesas Electronics products described in this document within the range specified by Renesas Electronics, especially with respect to the maximum rating, operating supply voltage range, movement power voltage range, heat radiation characteristics, installation and other product characteristics. Renesas Electronics shall have no liability for malfunctions or damages arising out of the use of Renesas Electronics products beyond such specified ranges.
- Although Renesas Electronics endeavors to improve the quality and reliability of its products, semiconductor products have specific characteristics such as the occurrence of failure at a certain rate and malfunctions under certain use conditions. Further, Renesas Electronics products are not subject to radiation resistance design. Please be sure to implement safety measures to guard them against the possibility of physical injury, and injury or damage caused by fire in the event of the failure of a Renesas Electronics product, such as safety design for hardware and software including but not limited to redundancy, fire control and malfunction prevention, appropriate treatment for aging degradation or any other appropriate measures. Because the evaluation of microcomputer software alone is very difficult, please evaluate the safety of the final products or system manufactured by you.
- Please contact a Renesas Electronics sales office for details as to environmental matters such as the environmental compatibility of each Renesas Electronics product. Please use Renesas Electronics products in compliance with all applicable laws and regulations that regulate the inclusion or use of controlled substances, including without limitation, the EU RoHS Directive. Renesas Electronics assumes no liability for damages or losses occurring as a result of your noncompliance with applicable laws and regulations.
- This document may not be reproduced or duplicated, in any form, in whole or in part, without prior written consent of Renesas Electronics.
- Please contact a Renesas Electronics sales office if you have any questions regarding the information contained in this document or Renesas Electronics products, or if you have any other inquiries.
(Note 1) "Renesas Electronics" as used in this document means Renesas Electronics Corporation and also includes its majority-owned subsidiaries.
(Note 2) "Renesas Electronics product(s)" means any product developed or manufactured by or for Renesas Electronics.



SALES OFFICES

Renesas Electronics Corporation

<http://www.renesas.com>

Refer to "<http://www.renesas.com/>" for the latest and detailed information.

Renesas Electronics America Inc.
2880 Scott Boulevard Santa Clara, CA 95050-2554, U.S.A.
Tel: +1-408-588-6000, Fax: +1-408-588-6130

Renesas Electronics Canada Limited
1101 Nicholson Road, Newmarket, Ontario L3Y 9C3, Canada
Tel: +1-905-898-5441, Fax: +1-905-898-3220

Renesas Electronics Europe Limited
Dukes Meadow, Millboard Road, Bourne End, Buckinghamshire, SL8 5FH, U.K
Tel: +44-1628-585-100, Fax: +44-1628-585-900

Renesas Electronics Europe GmbH
Arcadiastrasse 10, 40472 Düsseldorf, Germany
Tel: +49-211-65030, Fax: +49-211-6503-1327

Renesas Electronics (China) Co., Ltd.
7th Floor, Quantum Plaza, No.27 Zhichunlu Haidian District, Beijing 100083, P.R.China
Tel: +86-10-8235-1155, Fax: +86-10-8235-7679

Renesas Electronics (Shanghai) Co., Ltd.
Unit 204, 205, AZIA Center, No.1233 Lujiazui Ring Rd., Pudong District, Shanghai 200120, China
Tel: +86-21-5877-1818, Fax: +86-21-6887-7858 / -7898

Renesas Electronics Hong Kong Limited
Unit 1601-1613, 16/F., Tower 2, Grand Century Place, 193 Prince Edward Road West, Mongkok, Kowloon, Hong Kong
Tel: +852-2886-9318, Fax: +852-2886-9022/9044

Renesas Electronics Taiwan Co., Ltd.
7F, No. 363 Fu Shing North Road Taipei, Taiwan
Tel: +886-2-8175-9600, Fax: +886-2-8175-9670

Renesas Electronics Singapore Pte. Ltd.
1 HarbourFront Avenue, #06-10, Keppel Bay Tower, Singapore 098632
Tel: +65-6213-0200, Fax: +65-6278-8001

Renesas Electronics Malaysia Sdn.Bhd.
Unit 906, Block B, Menara Amcorp, Amcorp Trade Centre, No. 18, Jln Persiaran Barat, 46050 Petaling Jaya, Selangor Darul Ehsan, Malaysia
Tel: +60-3-7955-9390, Fax: +60-3-7955-9510

Renesas Electronics Korea Co., Ltd.
11F., Samik Laviel'or Bldg., 720-2 Yeoksam-Dong, Kangnam-Ku, Seoul 135-080, Korea
Tel: +82-2-558-3737, Fax: +82-2-558-5141