

## Description

The GM1431 is a three terminal adjustable shunt regulator with thermal stability guaranteed over temperature. Output voltage can be adjusted to any value between 2.5V ( $V_{ref}$ ) and 36V by using two external resistors. The GM1431 has a typical dynamic output impedance of 0.2  $\Omega$ . Active output circuitry provides a very unique turn on characteristic, making the GM1431 an excellent turn on replacement for zener diodes in many applications such as onboard regulation and adjustable power supplies. The GM1431 is an ideal voltage reference for 3.0 to 3.3V switching power supplies.

The GM1431 shunt regulator is available with 3 voltage tolerances, 0.5%, 1.0% and 2.0% over  $T_A = 0^\circ\text{C}$  to  $+70^\circ\text{C}$ , and four package options (SOT-23, TO-92, SOT-89 and SOP-8). Whatever your application is, the GM1431 offers the optimum combination of performance, reliability, and economy.

## Features

- ◆ Sink Current Capability 1 mA to 100mA
- ◆ Low dynamic output impedance, 0.2  $\Omega$  typ.
- ◆ 0.5%, 1% or 2% reference voltage tolerance
- ◆ Alternate for TL431, TL431, LM431 & AS431
- ◆ Temperature range  $0^\circ\text{C}$  to  $+70^\circ\text{C}$
- ◆ Available in SOT-23, TO-92, SOT-89 and SOP-8 packages

## Application

Switching power supplies

Linear regulators

Adjustable supplies

Battery-operated computers

Computer disk drives

Instrumentation

### LOGIC SYMBOL



### BLOCK DIAGRAM (POSITIVE LOGIC)

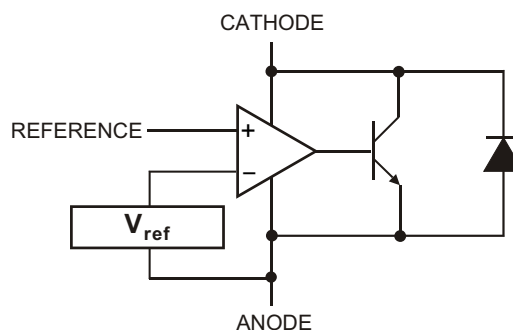

#### ◆ MARKING INFORMATION & PIN CONFIGURATIONS (TOP VIEW)

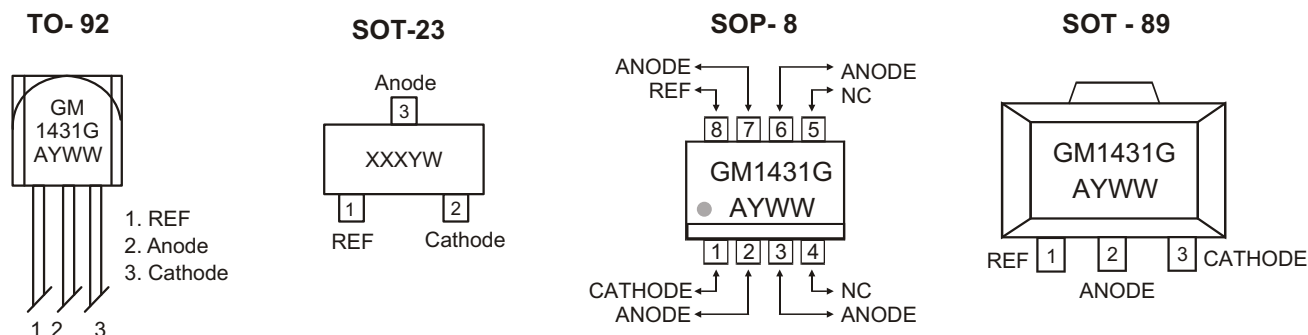

XXX = Marking Code  
 G\*\* = Grade  
 A = Assembly Location  
 Y = Year  
 WW, W= Weekly

#### ◆ ORDERING INFORMATION

Ordering Number	Precision	Device code	Grade	Package	Shipping
GM1431AT92B	0.5%		A	TO-92	1,000 Units/ ESD Bag
GM1431AT92RL	0.5%		A	TO-92	2,000 Units/ Ammo Pack(Tape)
GM1431AST23R	0.5%	NAA		SOT-23	3,000 Units/ Tape & Reel
GM1431AS8T	0.5%		A	SOP-8	100 Units/ Tube
GM1431AS8R	0.5%		A	SOP-8	2,500 Units/ Tape & Reel
GM1431AST89R	0.5%		A	SOT-89	1,000 Units/ Tape & Reel
GM1431BT92B	1%		B	TO-92	1,000 Units/ ESD Bag
GM1431BT92RL	1%		B	TO-92	2,000 Units/ Ammo Pack(Tape)
GM1431BST23R	1%	NAB		SOT-23	3,000 Units/ Tape & Reel
GM1431BS8T	1%		B	SOP-8	100 Units/ Tube
GM1431BS8R	1%		B	SOP-8	2,500 Units/ Tape & Reel
GM1431BST89R	1%		B	SOT-89	1,000 Units/ Tape & Reel
GM1431CT92B	2%		C	TO-92	1,000 Units/ ESD Bag
GM1431CT92RL	2%		C	TO-92	2,000 Units/ Ammo Pack(Tape)
GM1431CST23R	2%	NAC		SOT-23	3,000 Units/ Tape & Reel
GM1431CS8T	2%		C	SOP-8	100 Units/ Tube
GM1431CS8R	2%		C	SOP-8	2,500 Units/ Tape & Reel
GM1431CST89R	2%		C	SOT-89	1,000 Units/ Tape & Reel

\* For detail Ordering Number identification, please see last page.

\*\*Grade A: indicates Precision of 0.5%, B: indicates Precision of 1%, C: indicates Precision of 2%

#### ◆ EQUIVALENT SCHEMATIC

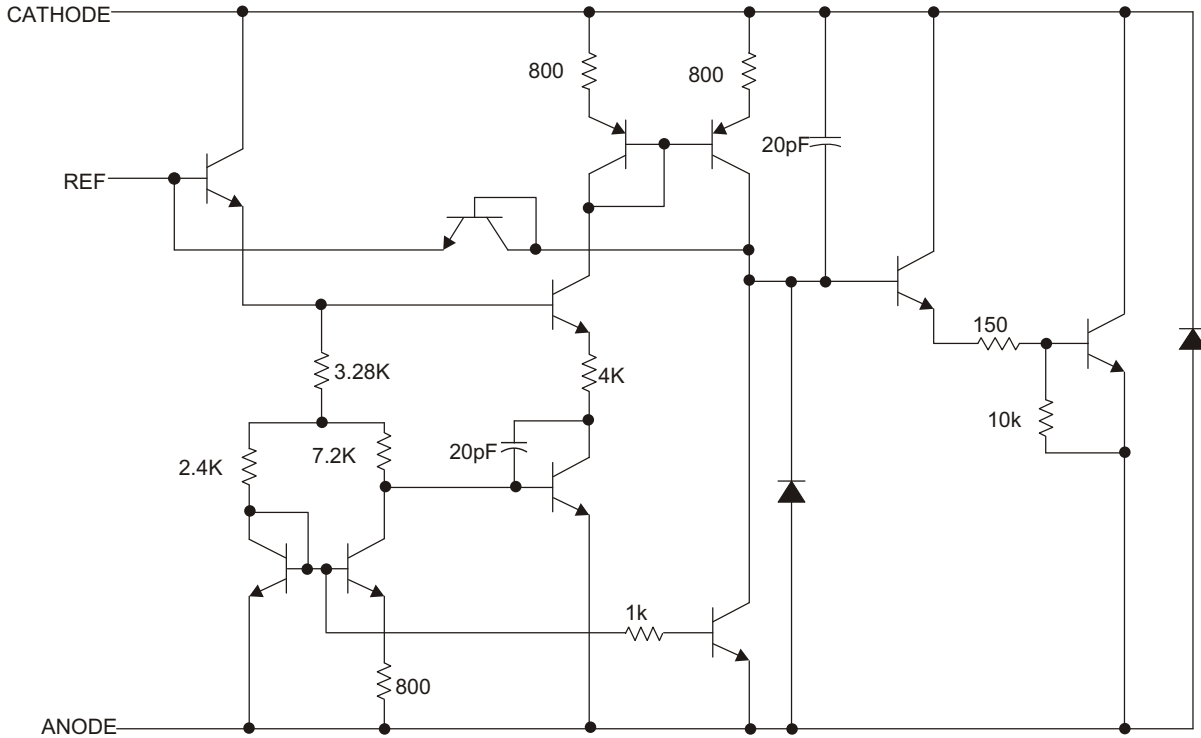

\* All component values are nominal.  
Pin numbers shown are for the D package.

◆ **ABSOLUTE MAXIMUM RATINGS** (over free-air temperature range except as noted)

PARAMETER	SYMBOL	VALUE	UNIT
Cathode Voltage <sup>(1)</sup>	$V_{KA}$	37	V
Continuous cathode current	$I_K$	-100 to 150	mA
Reference input current range	$I_{ref}$	-50 $\mu$ A to 10mA	mA
Power dissipation at $T_A = 25^\circ\text{C}$ SOT-23 SOP-8 TO-92 SOT-89	$P_D$	0.23 0.60 0.78 0.80	W
Package thermal impedance <sup>(2, 3)</sup> SOT-23 TO-92 SOP-8 SOT-89	$J_A$	336 132 163 132	$^\circ\text{C/W}$
Operating ambient temperature range	$T_A$	0 to 70	$^\circ\text{C}$
Lead temperature (soldering) 10 seconds	$T_{LEAD}$	260	$^\circ\text{C}$

These are stress ratings only. Functional operation of the device at these or any conditions beyond the "recommended operating conditions" is not implied. Exposure to absolute maximum rated conditions may affect device reliability.

**NOTES:**

- Voltage values are with respect to the anode except as noted.
- Maximum power dissipation is a function of  $T_{J(max)}$ ,  $J_A$  and  $T_A$ . Maximum allowable power dissipation at any allowable ambient temperature is  $P_D = (T_{J(max)} - T_A) / J_A$ .
- Package thermal impedance is calculated per JESD 51.

◆ **RECOMMENDED OPERATING CONDITIONS**

PARAMETER	SYMBOL	MINIMUM	MAXIMUM	UNIT
Cathode Voltage	$V_{KA}$	$V_{ref}$	36	V
Cathode Current	$I_K$	1.0	100	mA

◆ **ELECTRICAL CHARACTERISTICS** ( $T_A = 25^\circ\text{C}$  unless otherwise noted)

**GM1431A (0.5%)**

PARAMETER	CONDITION		MIN	TYP	MAX	UNIT
Reference Input Voltage	$V_{\text{ref}}$	$V_{\text{KA}} = V_{\text{ref}}, I_{\text{K}} = 10 \text{ mA}, T_A = 25^\circ\text{C}^{(1)}$ $V_{\text{KA}} = V_{\text{ref}}, I_{\text{K}} = 10 \text{ mA}, T_A = 0 \text{ to } 70^\circ\text{C}^{(1)}$	2.487	2.500	2.512	V
$V_{\text{ref}}$ temp deviation	$V_{\text{dev}}$	$V_{\text{KA}} = V_{\text{ref}}, I_{\text{K}} = 10 \text{ mA}^{(1)}, T_A = \text{full range}$		4	17	mV
Ratio of change in $V_{\text{ref}}$ to change in $V_{\text{KA}}$	$\frac{V_{\text{ref}}}{V_{\text{KA}}}$	$I_{\text{K}} = 10 \text{ mA}$ $V_{\text{KA}} = 10 \text{ V to } V_{\text{ref}}$ $V_{\text{KA}} = 36 \text{ V to } 10 \text{ V}$	-2.7 -2.0	-1.0 -0.4		mV/V
Reference input current	$I_{\text{ref}}$	$I_{\text{K}} = 10 \text{ mA}, R1 = 10 \text{ K}, R2 = \infty^{(2)}$		1.3	4.0	A
Deviation of reference input current over full temperature range	$I_{\text{ref(dev)}}$	$I_{\text{K}} = 10 \text{ mA}, R1 = 10 \text{ K}, R2 = \infty^{(2)}$ <b><math>T_A = \text{full range}</math></b>		0.4	1.2	A
Minimum operating current	$I_{\text{K(min)}}$	$V_{\text{KA}} = V_{\text{ref}}^{(1)}$		0.4	1.0	mA
Off-state cathode current	$I_{\text{K(off)}}$	$V_{\text{KA}} = 36 \text{ V}, V_{\text{ref}} = 0 \text{ V}^{(3)}$ $V_{\text{KA}} = 16 \text{ V}, V_{\text{ref}} = 0 \text{ V}^{(3)}$		0.1	1	A
Dynamic impedance	$ Z_{\text{KA}} $	$f \leq 1 \text{ kHz}, V_{\text{KA}} = V_{\text{ref}}, I_{\text{K}} = 100 \text{ A to } 100 \text{ mA}^{(1)}$		0.2	0.50	

**GM1431B (1.0%)**

PARAMETER	CONDITION		MIN	TYP	MAX	UNIT
Reference Input Voltage	$V_{\text{ref}}$	$V_{\text{KA}} = V_{\text{ref}}, I_{\text{K}} = 10 \text{ mA}, T_A = 25^\circ\text{C}^{(1)}$ $V_{\text{KA}} = V_{\text{ref}}, I_{\text{K}} = 10 \text{ mA}, T_A = 0 \text{ to } 70^\circ\text{C}^{(1)}$	2.474	2.500	2.525	V
$V_{\text{ref}}$ temp deviation	$V_{\text{dev}}$	$V_{\text{KA}} = V_{\text{ref}}, I_{\text{K}} = 10 \text{ mA}^{(1)}, T_A = \text{full range}$		4	17	mV
Ratio of change in $V_{\text{ref}}$ to change in $V_{\text{KA}}$	$\frac{V_{\text{ref}}}{V_{\text{KA}}}$	$I_{\text{K}} = 10 \text{ mA}$ $V_{\text{KA}} = 10 \text{ V to } V_{\text{ref}}$ $V_{\text{KA}} = 36 \text{ V to } 10 \text{ V}$	-2.7 -2.0	-1.0 -0.4		mV/V
Reference input current	$I_{\text{ref}}$	$I_{\text{K}} = 10 \text{ mA}, R1 = 10 \text{ K}, R2 = \infty^{(2)}$		1.3	4.0	A
Deviation of reference input current over full temperature range	$I_{\text{ref(dev)}}$	$I_{\text{K}} = 10 \text{ mA}, R1 = 10 \text{ K}, R2 = \infty^{(2)}$ <b><math>T_A = \text{full range}</math></b>		0.4	1.2	A
Minimum operating current	$I_{\text{K(min)}}$	$V_{\text{KA}} = V_{\text{ref}}^{(1)}$		0.4	1.0	mA
Off-state cathode current	$I_{\text{K(off)}}$	$V_{\text{KA}} = 36 \text{ V}, V_{\text{ref}} = 0 \text{ V}^{(3)}$ $V_{\text{KA}} = 16 \text{ V}, V_{\text{ref}} = 0 \text{ V}^{(3)}$		0.1	1	A
Dynamic impedance	$ Z_{\text{KA}} $	$f \leq 1 \text{ kHz}, V_{\text{KA}} = V_{\text{ref}}, I_{\text{K}} = 100 \text{ A to } 100 \text{ mA}^{(1)}$		0.2	0.50	

**NOTES:**

- (1) See test circuit 1 on page 5.  
 (2) See test circuit 2 on page 5.  
 (3) See test circuit 3 on page 5.

◆ **ELECTRICAL CHARACTERISTICS** ( $T_A = 25^\circ\text{C}$  unless otherwise noted)

**GM1431C (2.0%)**

PARAMETER	CONDITION		MIN	TYP	MAX	UNIT
Reference Input Voltage	$V_{ref}$	$V_{KA} = V_{ref}, I_K = 10\text{ mA}, T_A = 25^\circ\text{C}^{(1)}$ $V_{KA} = V_{ref}, I_K = 10\text{ mA}, T_A = 0\text{ to }70^\circ\text{C}^{(1)}$	2.45	2.500	2.55	V
$V_{ref}$ temp deviation	$V_{dev}$	$V_{KA} = V_{ref}, I_K = 10\text{ mA}^{(1)}, T_A = \text{full range}$		4	17	mV
Ratio of change in $V_{ref}$ to change in $V_{KA}$	$\frac{V_{ref}}{V_{KA}}$	$I_K = 10\text{ mA}$ $V_{KA} = 10\text{V to }V_{ref}$ $V_{KA} = 36\text{V to }10\text{V}$	-2.7 -2.0	-1.0 -0.4		mV/V
Reference input current	$I_{ref}$	$I_K = 10\text{ mA}, R1 = 10\text{K}, R2 = \infty^{(2)}$		1.3	4.0	A
Deviation of reference input current over full temperature range	$I_{ref(dev)}$	$I_K = 10\text{ mA}, R1 = 10\text{K}, R2 = \infty^{(2)}$ <b><math>T_A = \text{full range}</math></b>		0.4	1.2	A
Minimum operating current	$I_{K(min)}$	$V_{KA} = V_{ref}^{(1)}$		0.4	1.0	mA
Off-state cathode current	$I_{K(off)}$	$V_{KA} = 36\text{V}, V_{ref} = 0\text{V}^{(3)}$ $V_{KA} = 16\text{V}, V_{ref} = 0\text{V}^{(3)}$		0.1	1	A
Dynamic impedance	$ Z_{KA} $	$f \leq 1\text{kHz}, V_{KA} = V_{ref}, I_K = 100\text{ A to }100\text{mA}^{(1)}$		0.2	0.50	

**NOTES:**

- (1) See test circuit 1.
- (2) See test circuit 2.
- (3) See test circuit 3.

◆ **TEST CIRCUITS**

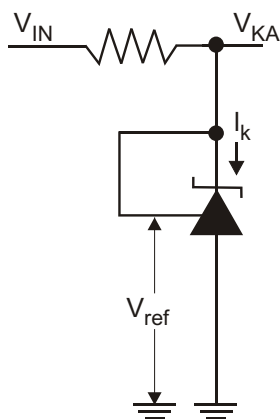

**Test Circuit 1**  
 $V_{KA} = V_{ref}$

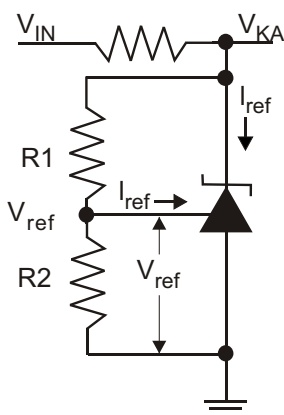

**Test Circuit 2**  
 $V_{KA} > V_{ref}$

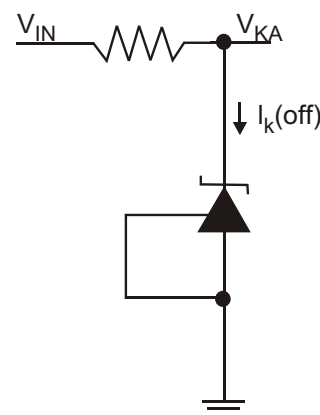

**Test Circuit 3**  
**Off-State**

#### ◆ TYPICAL APPLICATIONS GM1431A, GM1431B

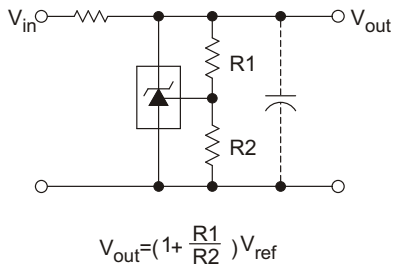

Figure 1. Shunt Regulator

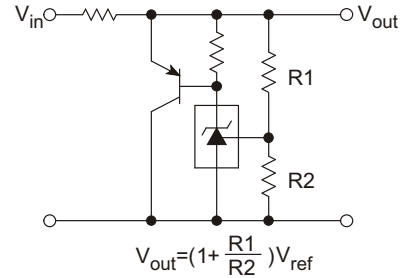

Figure 2. High Current Shunt Regulator

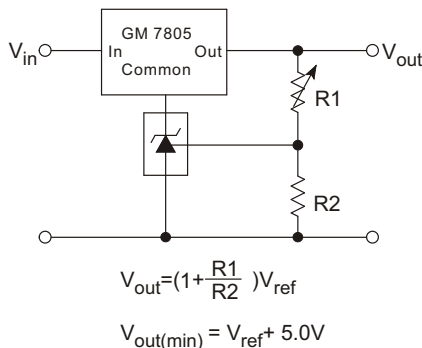

Figure 3. Output Control for a Three Terminal Fixed Regulator

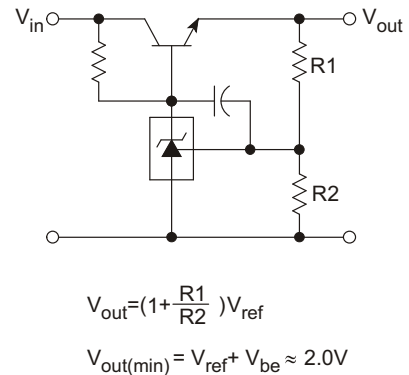

Figure 4. Series Pass Regulator

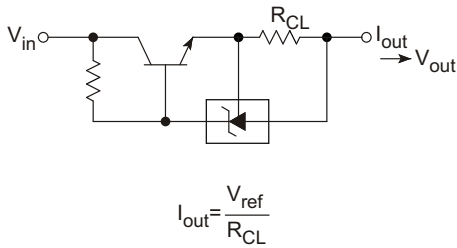

Figure 5. Constant Current Source

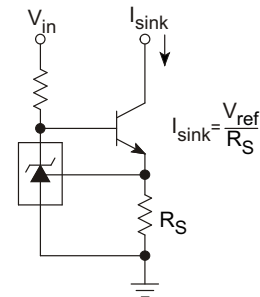

Figure 6. Constant Current Sink

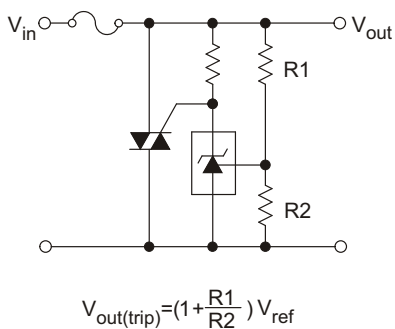

Figure 7. TRIAC Crowbar

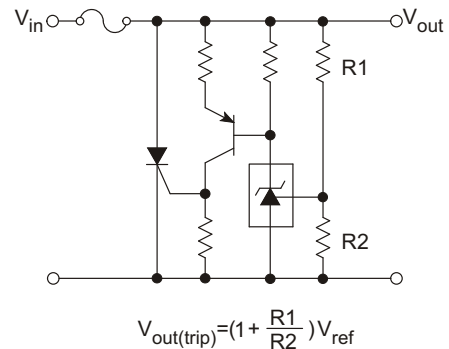
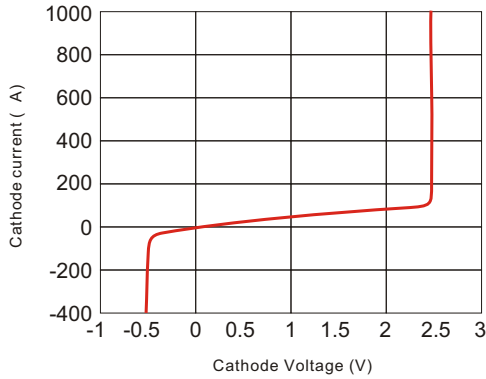
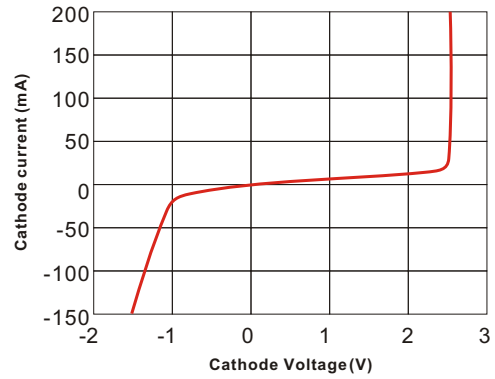

Figure 8. SCR Crowbar

#### ◆ Typical Performance Characteristics



**Figure 9. Cathode Current vs. Cathode Voltage**



**Figure 10. Cathode Current vs. Cathode Voltage**

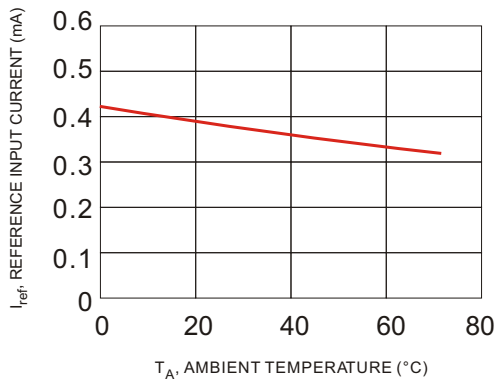

**Figure 11. Reference Input Current versus Ambient Temperature**

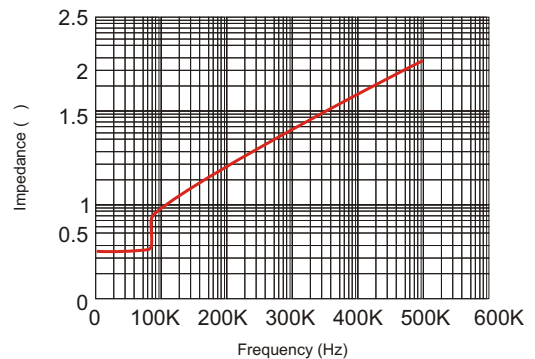

**Figure 12. Dynamic Impedance Frequency**

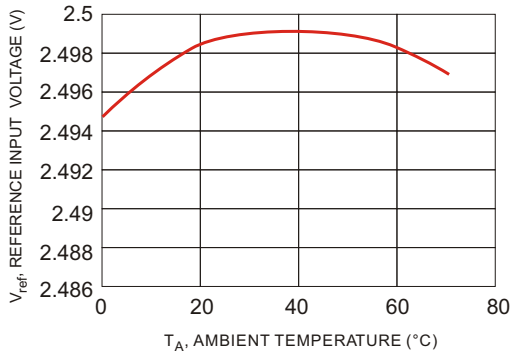

**Figure 13. Reference Input Voltage versus Ambient Temperature**

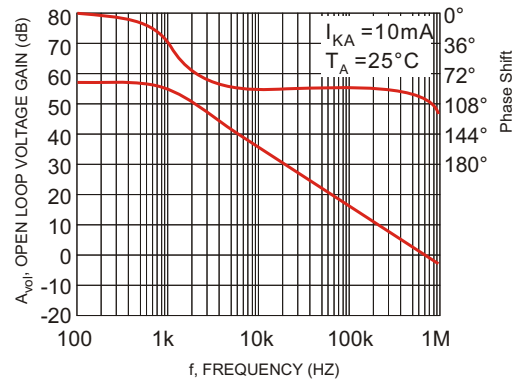

**Figure 14. Open-Loop Voltage Gain vs. Frequency**

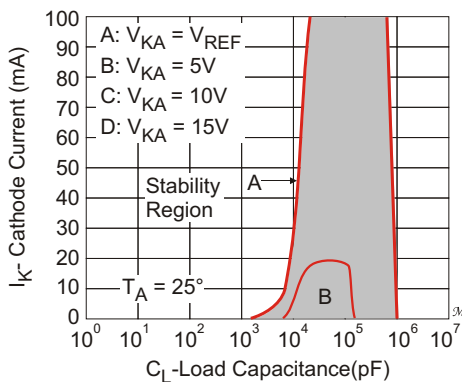

**Figure 15. Stability Boundary Conditions**  
(No Oscillation at  $V_{KA}=10V$  and  $V_{KA}=15V$ )



◆ **Design Guide for AC-DCSMPs** (Switching Mode Power Supply)

**Use of Shunt Regulator in Transformer Secondary Side Control**

This example is applicable to both forward transformers and flyback transformers. A shunt regulator is used on the secondary side as an error amplifier, and feedback to the primary side is provided via a photocoupler.

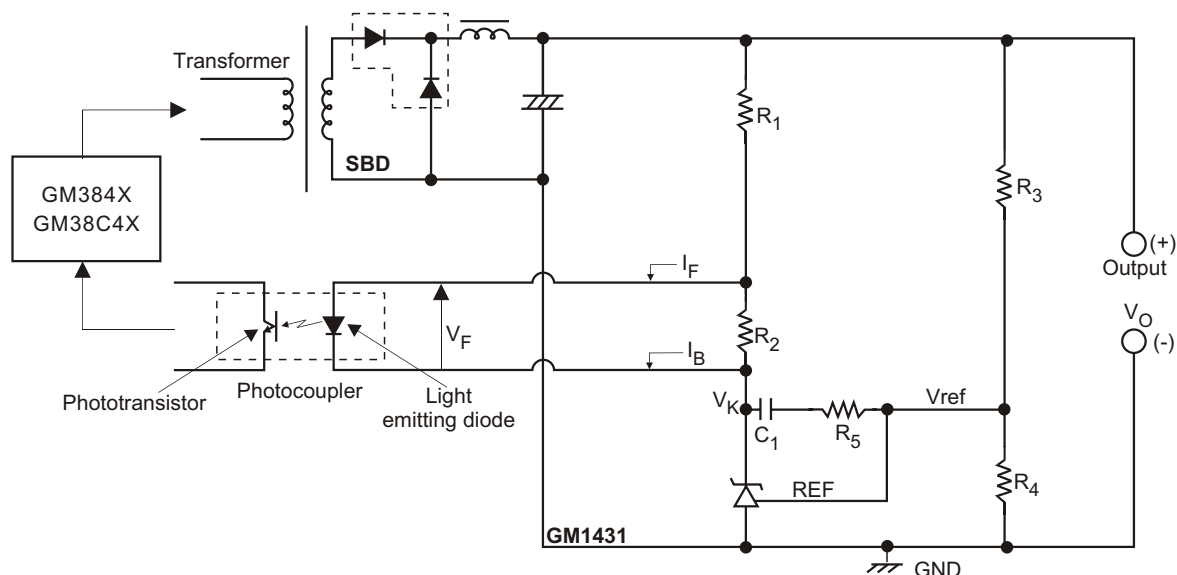

Figure 16. Typical Shunt Regulator/ Error Amplifier

**Determination of External Constants for the Shunt Regulator**

**Dc characteristic determination:** In figure 16,  $R_1$  and  $R_2$  are protection resistor for the light emitting diode in the photocoupler, and  $R_2$  is a bypass resistor to feed  $I_K$  Minimum, and these are determined as shown below. The photocoupler specification should be obtained separately from the manufacturer. Using the parameters in figure 16, the following formulas are obtained:

$$R_1 = \frac{V_O - V_F - V_K}{I_F + I_B}, R_2 = \frac{V_F}{I_B}$$

$V_K$  is the GM1431 operating voltage, and is set at around 3V, taking into account a margin for fluctuation.  $R_2$  is the current shunt resistance for the light emitting diode, in which a bias current  $I_B$  of around  $1/5 I_F$  flows.

Next, the output voltage can be determined by  $R_3$  and  $R_4$ , and the following formula is obtained:

$$V_O = \frac{R_3 + R_4}{R_4} \times V_{ref}, V_{ref} = 2.5V \text{ Typ}$$

The absolute values of  $R_3$  and  $R_4$  are determined by the GM1431 reference input current  $I_{ref}$  and the AC characteristics described in the next section. The  $I_{ref}$  value is around  $1.3\mu A$  Typ.

### ◆ AC Characteristic Determination:

This refers to the determination of the gain frequency characteristic of the shunt regulator as an error amplifier. Taking the configuration in figure 16, the error amplifier characteristic is as shown in figure 17.

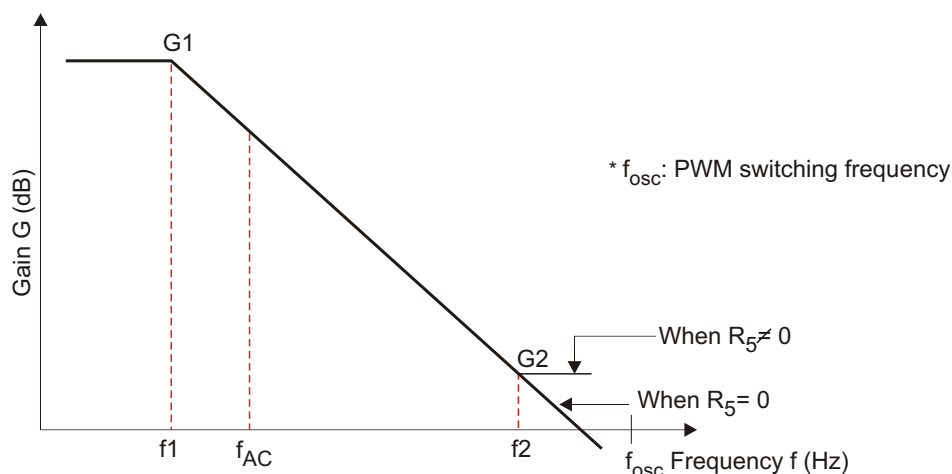

Figure 17. GM1431 Error Amplification Characteristic

In Figure 17, the following formulas are obtained:

Gain

$$G_1 = G_0 \approx 50 \text{ dB to } 60 \text{ dB (determined by shunt regulator)}$$

$$G_2 = \frac{R_5}{R_3}$$

Corner frequencies

$$f_1 = 1/(2 \cdot C_1 \cdot G_0 \cdot R_3)$$

$$f_2 = 1/(2 \cdot C_1 \cdot R_5)$$

$G_0$  is the shunt regulator open-loop gain; this is given by the reciprocal of the reference voltage fluctuation  $V_{ref}/V_{KA}$ , and is approximately 50 dB.

### Practical Example

Consider the example of a photocoupler, with an internal light emitting diode  $V_F = 1.05 \text{ V}$  and  $I_F = 2.5 \text{ mA}$ , power supply output voltage  $V_2 = 5 \text{ V}$ , and bias resistance  $R_2$  current of approximately  $1/5 I_F$  at  $0.5 \text{ mA}$ . If the shunt regulator  $V_K = 3 \text{ V}$ , the following values are found.

$$R_1 = \frac{5\text{V} - 1.05\text{V} - 3\text{V}}{2.5\text{mA} + 0.54\text{mA}} = 316$$

$$R_2 = \frac{1.05\text{V}}{0.54\text{mA}} = 2.1 \text{ k}$$

Next, assume that  $R_3 = R_4 = 10 \text{ k}$ . This gives a  $5 \text{ V}$  output. If  $R_5 = 3.3 \text{ k}$  and  $C_1 = 0.022 \text{ }\mu\text{F}$ , the following values are found.

$$G_2 = 3.3 \text{ k} / 10 \text{ k} = 0.33 \text{ times } (-10 \text{ dB})$$

$$f_1 = 1 / (2 \times 0.022 \text{ }\mu\text{F} \times 316 \times 10 \text{ k}) = 2.3 \text{ (Hz)}$$

$$f_2 = 1 / (2 \times 0.022 \text{ }\mu\text{F} \times 3.3 \text{ k}) = 2.2 \text{ (kHz)}$$

#### ◆ SOT-89 PACKAGE OUTLINE DIMENSIONS

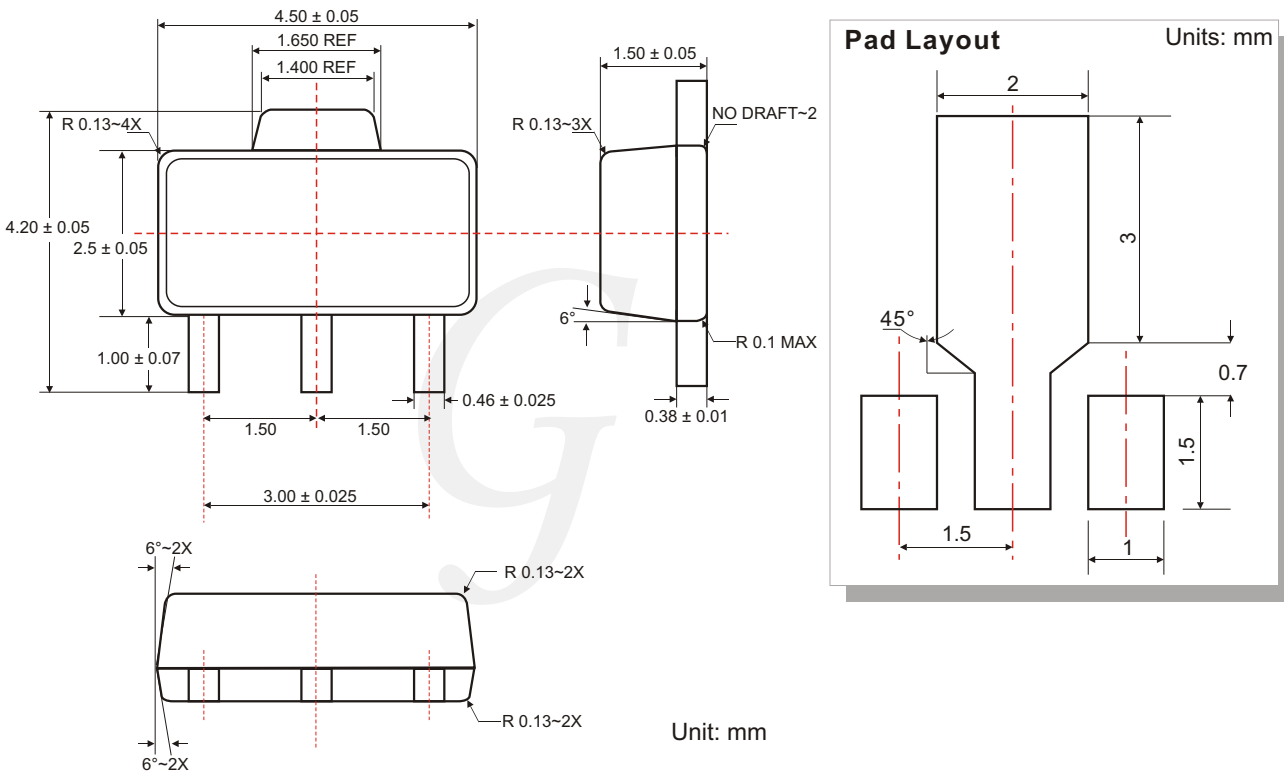

#### ◆ SOT-23 PACKAGE OUTLINE DIMENSIONS

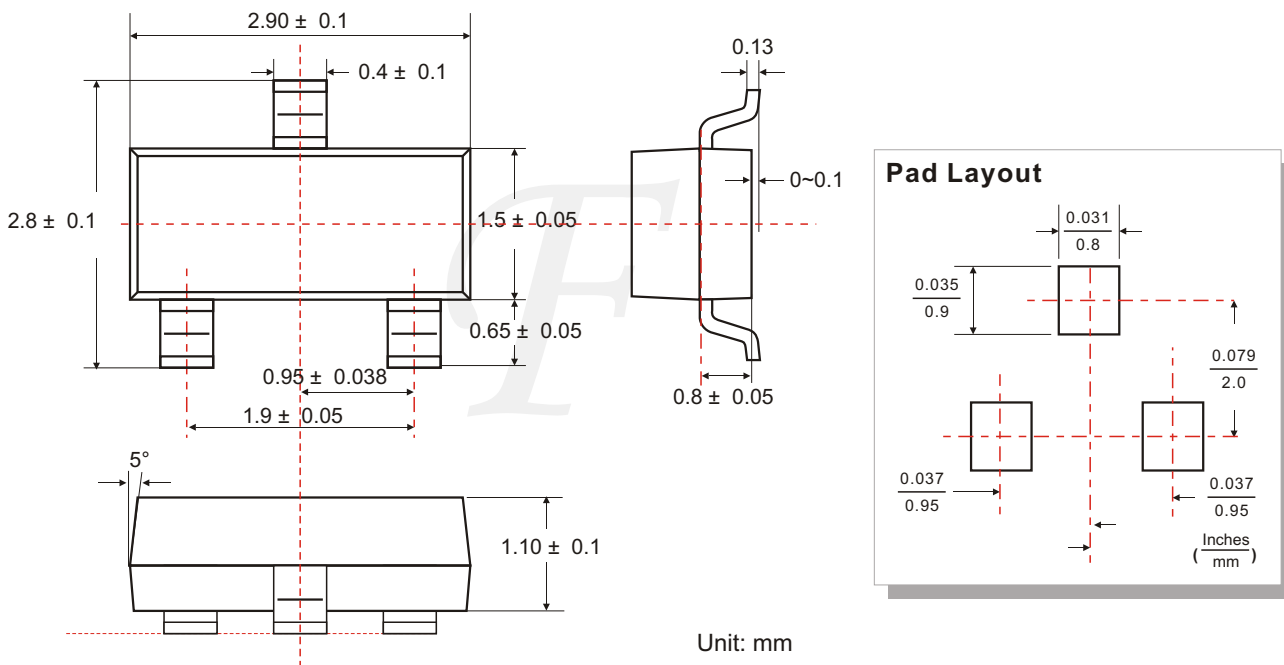

#### ◆ SOP-8 PACKAGE OUTLINE DIMENSIONS

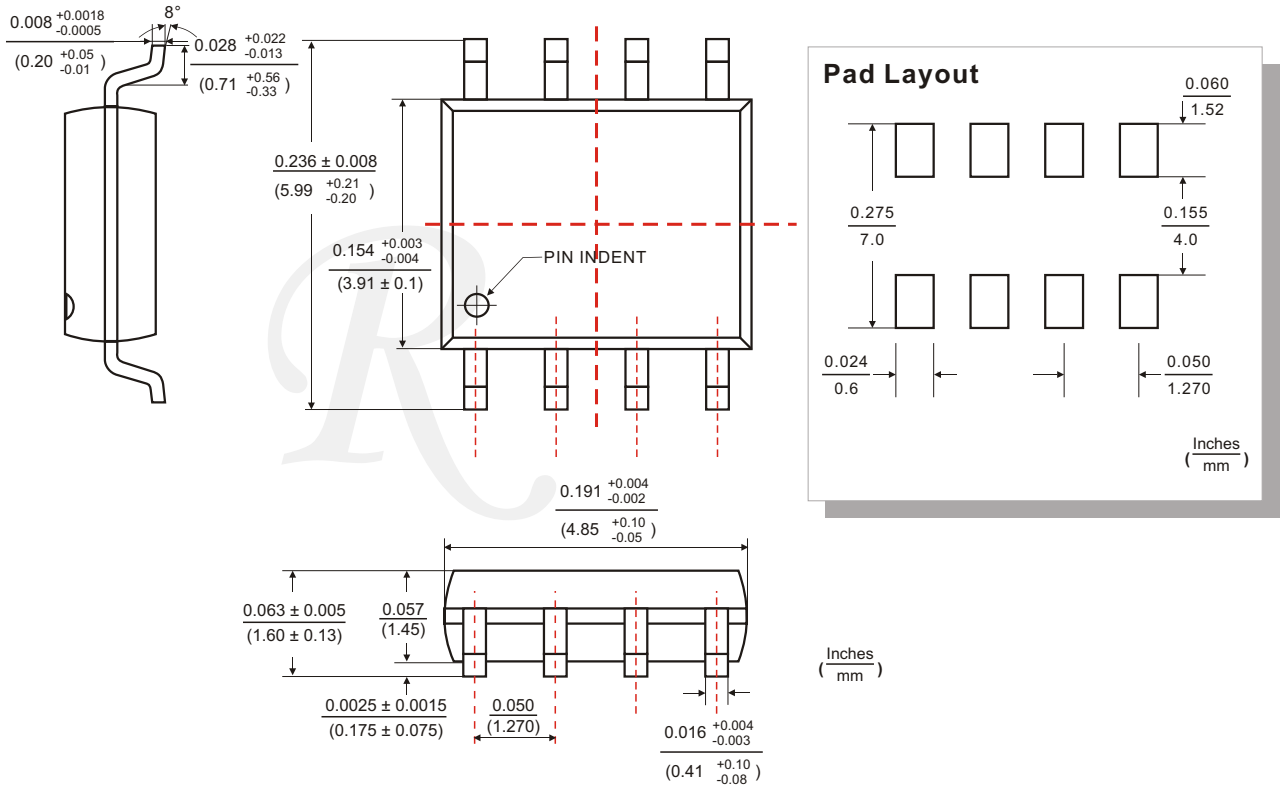

#### ◆ TO-92 PACKAGE OUTLINE DIMENSIONS

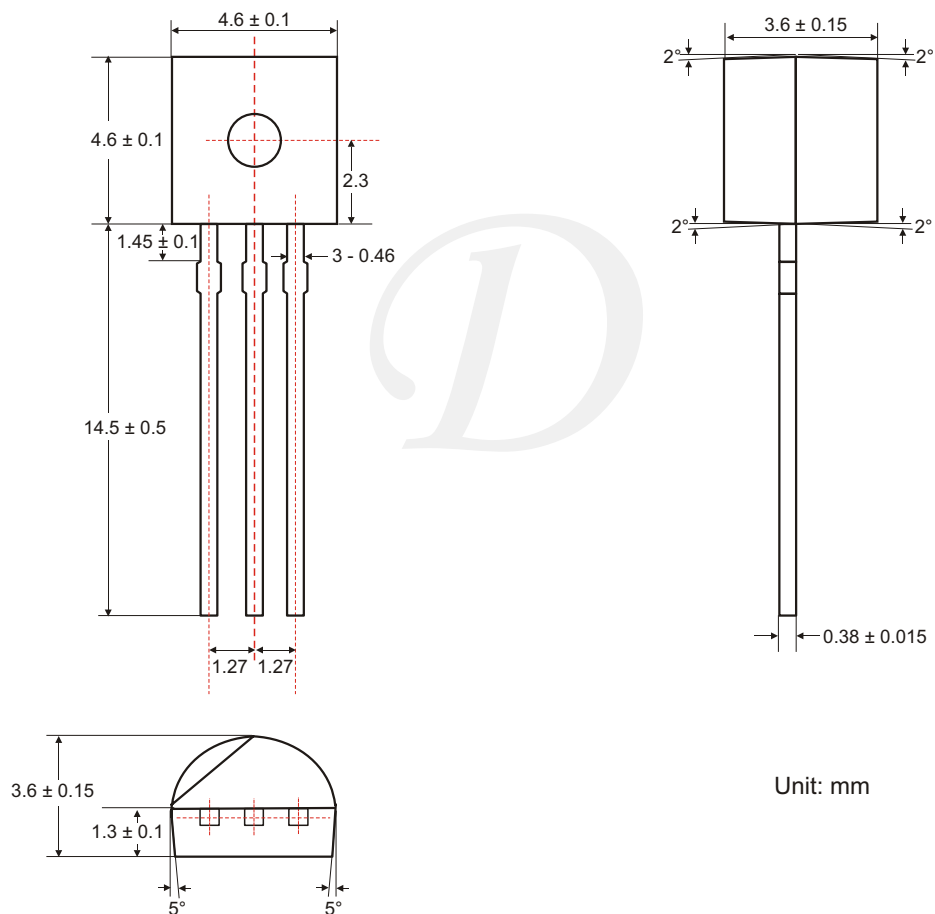

◆ ORDERING NUMBER

