



MOTOROLA SEMICONDUCTORS

P.O. BOX 20912 • PHOENIX, ARIZONA 85036

Product Preview

UNDervoltage SENSING CIRCUIT

The MC34064 is an undervoltage sensing circuit specifically designed for use as a reset controller in microprocessor-based systems. It offers the designer an economical solution for low voltage detection with a single external resistor. The MC34064 features a trimmed-in-package bandgap reference, and a comparator with precise thresholds and built-in hysteresis to prevent erratic reset operation. The open collector reset output is capable of sinking in excess of 10 mA, and operation is guaranteed down to 1.0 volt input with low standby current. These devices are packaged in 3-pin TO-226AA and 8-pin surface mount packages.

Applications include direct monitoring of the 5.0 volt MPU/logic power supply used in appliance, automotive, consumer and industrial equipment.

- Trimmed-In-Package Temperature Compensated Reference
- Precise Comparator Thresholds Guaranteed Over Temperature
- Comparator Hysteresis Prevents Erratic Reset
- Reset Output Capable of Sinking in Excess of 10 mA
- Internal Clamp Diode for Discharging Delay Capacitor
- Guaranteed Reset Operation with 1.0 Volt Input
- Low Standby Current
- Economical TO-226AA and Surface Mount Packages

REPRESENTATIVE BLOCK DIAGRAM

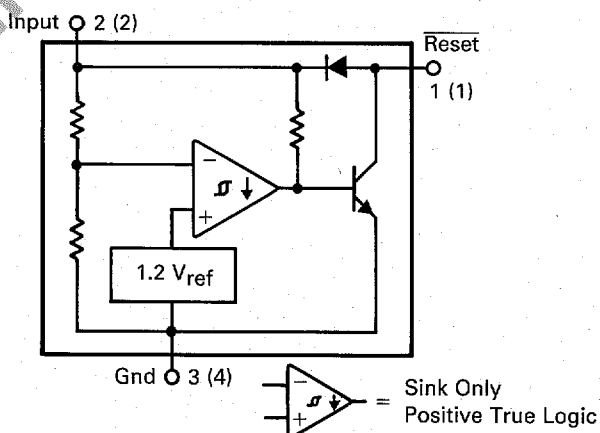

Pin numbers adjacent to terminals are for the 3-pin TO-226AA package.
Pin numbers in parenthesis are for the D suffix SO-8 package.

MC34064 MC33064

UNDervoltage SENSING CIRCUIT

SILICON MONOLITHIC
INTEGRATED CIRCUIT

P SUFFIX
PLASTIC PACKAGE
CASE 29-04



PIN 1. RESET
2. INPUT
3. GROUND

D SUFFIX
PLASTIC PACKAGE
CASE 751-02
SO-8



PIN 1. RESET
2. INPUT
3. N.C.
4. GROUND
5. N.C.
6. N.C.
7. N.C.
8. N.C.

ORDERING INFORMATION

Device	Temperature Range	Package
MC34064D-5	0°C to +70°C	Plastic SO-8
MC34064P-5		Plastic TO-226AA
MC33064D-5	-40°C to +85°C	Plastic SO-8
MC33064P-5		Plastic TO-226AA

MAXIMUM RATINGS

Rating	Symbol	Value	Unit
Power Input Supply Voltage	V_{in}	-1.0 to 10	V
Reset Output Voltage	V_O	10	V
Reset Output Sink Current	I_{Sink}	Internally Limited	mA
Clamp Diode Forward Current, Pin 1 to 2 (Note 1)	I_F	100	mA
Power Dissipation and Thermal Characteristics			
P Suffix, Plastic Package			
Maximum Power Dissipation @ $T_A = 25^\circ\text{C}$	P_D	625	mW
Thermal Resistance, Junction to Air	$R_{\theta JA}$	200	$^\circ\text{C/W}$
D Suffix, Plastic Package			
Maximum Power Dissipation @ $T_A = 25^\circ\text{C}$	P_D	625	mW
Thermal Resistance Junction to Air	$R_{\theta JA}$	200	$^\circ\text{C/W}$
Operating Junction Temperature	T_J	+150	$^\circ\text{C}$
Operating Ambient Temperature			
MC34064	T_A	0 to +70	$^\circ\text{C}$
MC33064		-40 to +85	
Storage Temperature Range	T_{stg}	-65 to +150	$^\circ\text{C}$

ELECTRICAL CHARACTERISTICS For typical values $T_A = 25^\circ\text{C}$, for min/max values T_A is the operating ambient temperature range that applies [Notes 2 and 3].

Characteristic	Symbol	Min	Typ	Max	Unit
COMPARATOR					
Threshold Voltage					
High State Output (V_{in} Increasing)	V_{IH}	4.5	4.61	4.7	V
Low State Output (V_{in} Decreasing)	V_{IL}	4.5	4.59	4.7	
Hysteresis	V_H	0.01	0.02	0.05	
RESET OUTPUT					
Output Sink Saturation					
($V_{in} = 4.0\text{ V}$, $I_{Sink} = 8.0\text{ mA}$)	V_{OL}	—	0.46	1.0	V
($V_{in} = 4.0\text{ V}$, $I_{Sink} = 2.0\text{ mA}$)		—	0.15	0.4	
($V_{in} = 1.0\text{ V}$, $I_{Sink} = 0.1\text{ mA}$)		—	—	0.1	
Output Sink Current (V_{in} , $\overline{\text{Reset}} = 4.0\text{ V}$)	I_{Sink}	10	27	60	mA
Output Off-State Leakage (V_{in} , $\overline{\text{Reset}} = 5.0\text{ V}$)	I_{OH}	—	0.02	0.5	μA
Clamp Diode Forward Voltage, Pin 1 to 2 ($I_F = 10\text{ mA}$)	V_F	0.6	0.9	1.2	V
TOTAL DEVICE					
Operating Input Voltage Range	V_{in}	1.0 to 6.5	—	—	V
Quiescent Input Current ($V_{in} = 5.0\text{ V}$)	I_{in}	—	390	500	μA

NOTES:

- Maximum package power dissipation limits must be observed.
- Low duty cycle pulse techniques are used during test to maintain junction temperature as close to ambient as possible.
- $T_{low} = 0^\circ\text{C}$ for MC34064
 $T_{low} = -40^\circ\text{C}$ for MC33064
 $T_{high} = +70^\circ\text{C}$ for MC34064
 $T_{high} = +85^\circ\text{C}$ for MC33064



FIGURE 1 — RESET OUTPUT VOLTAGE versus INPUT VOLTAGE

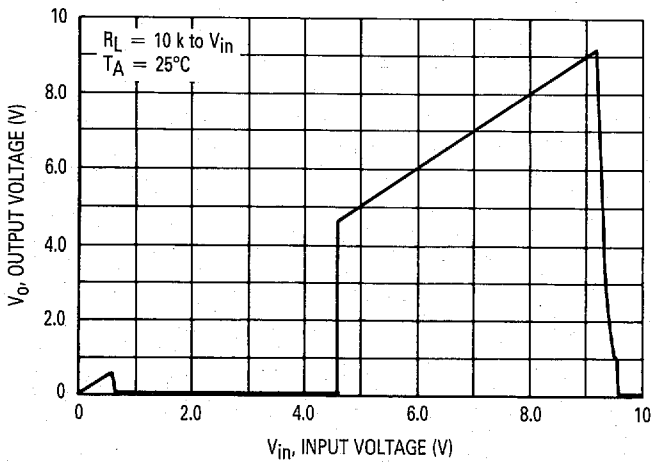

FIGURE 2 — RESET OUTPUT VOLTAGE versus INPUT VOLTAGE

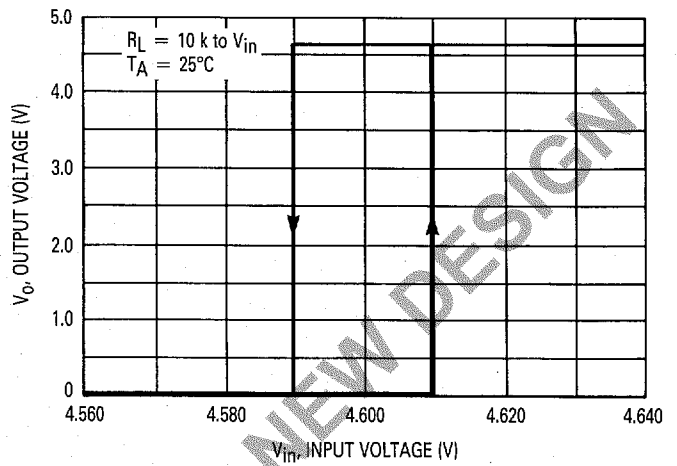

FIGURE 3 — COMPARATOR THRESHOLD VOLTAGE versus TEMPERATURE

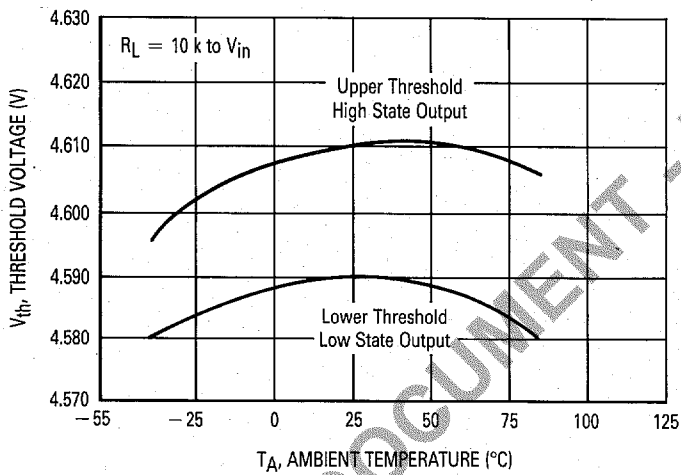

FIGURE 4 — INPUT CURRENT versus INPUT VOLTAGE

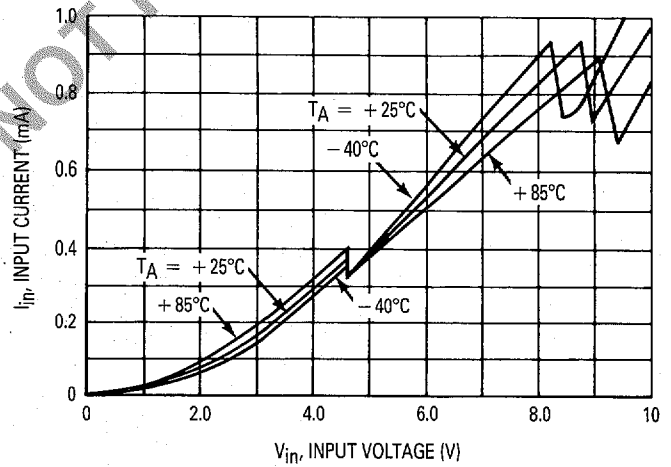

FIGURE 5 — RESET OUTPUT SATURATION versus SINK CURRENT

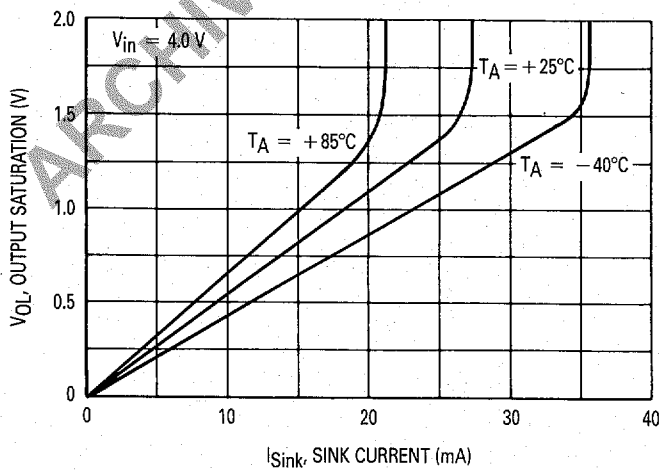

FIGURE 6 — CLAMP DIODE FORWARD CURRENT versus VOLTAGE

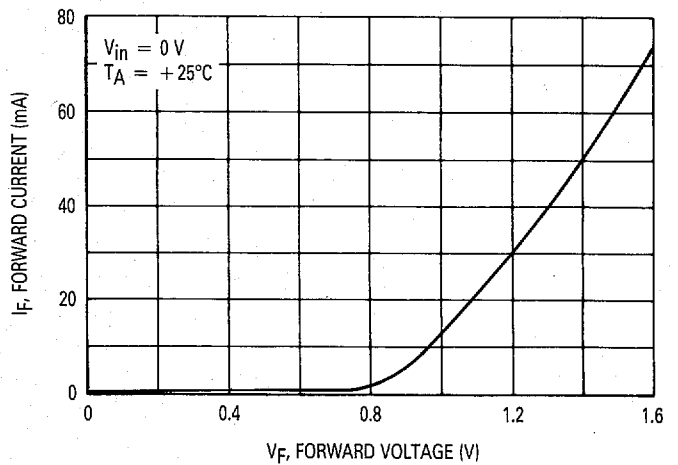

FIGURE 7 — LOW VOLTAGE MICROPROCESSOR RESET

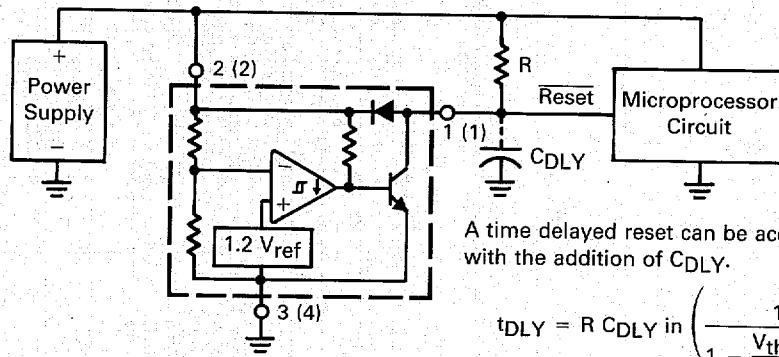

FIGURE 8 — VOLTAGE MONITOR

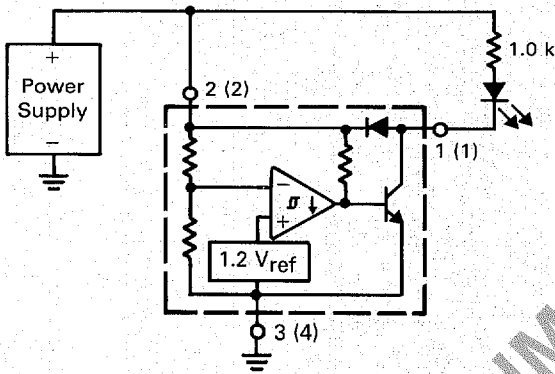

FIGURE 9 — SOLAR POWERED BATTERY CHARGER

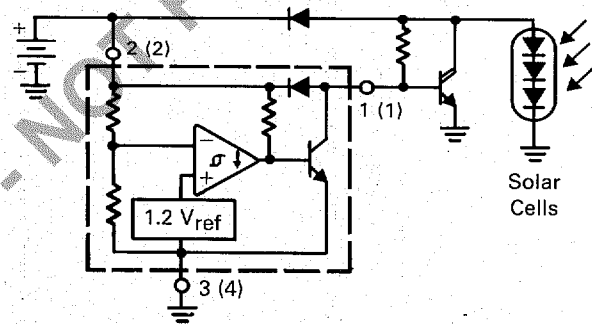
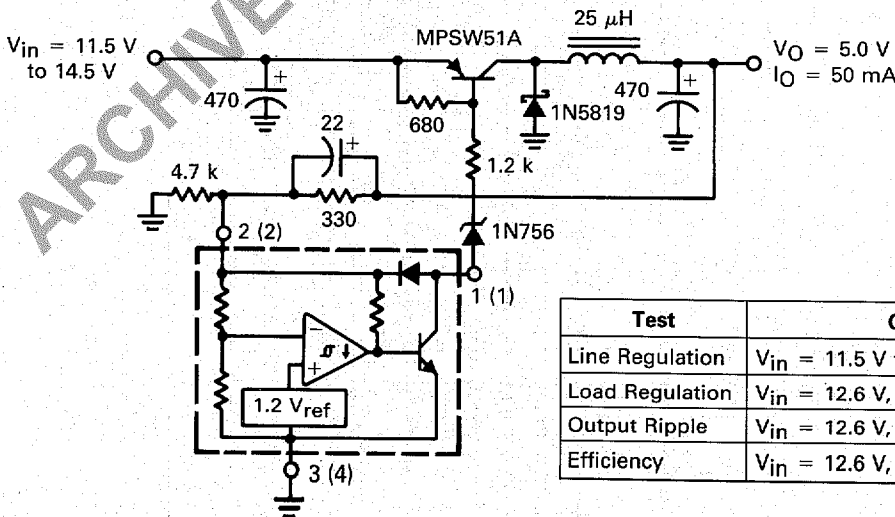

FIGURE 10 — LOW POWER SWITCHING REGULATOR



Test	Conditions	Results
Line Regulation	$V_{in} = 11.5 \text{ V to } 14.5 \text{ V}, I_O = 50 \text{ mA}$	35 mV
Load Regulation	$V_{in} = 12.6 \text{ V}, I_O = 0 \text{ mA to } 50 \text{ mA}$	12 mV
Output Ripple	$V_{in} = 12.6 \text{ V}, I_O = 50 \text{ mA}$	60 mV _{p-p}
Efficiency	$V_{in} = 12.6 \text{ V}, I_O = 50 \text{ mA}$	77%



OUTLINE DIMENSIONS

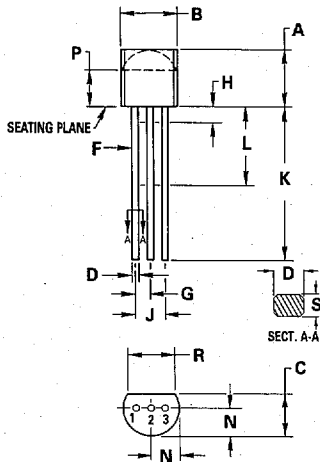

**P SUFFIX
PLASTIC PACKAGE
CASE 29-04**

- NOTES:
1. CONTOUR OF PACKAGE BEYOND ZONE "P" IS UNCONTROLLED.
 2. DIM "F" APPLIES BETWEEN "H" AND "L". DIM "D" & "S" APPLIES BETWEEN "L" & 12.70mm (0.5") FROM SEATING PLANE. LEAD DIM IS UNCONTROLLED IN "H" & BEYOND 12.70mm (0.5") FROM SEATING PLANE.
 3. CONTROLLING DIM: INCH.

DIM	MILLIMETERS		INCHES	
	MIN	MAX	MIN	MAX
A	4.32	5.33	0.170	0.210
B	4.45	5.20	0.175	0.205
C	3.18	4.19	0.125	0.165
D	0.41	0.55	0.016	0.022
F	0.41	0.48	0.016	0.019
G	1.15	1.39	0.045	0.055
H	—	2.54	—	0.100
J	2.42	2.66	0.095	0.105
K	12.70	—	0.500	—
L	6.35	—	0.250	—
N	2.04	2.66	0.080	0.105
P	2.93	—	0.115	—
R	3.43	—	0.135	—
S	0.39	0.50	0.015	0.020

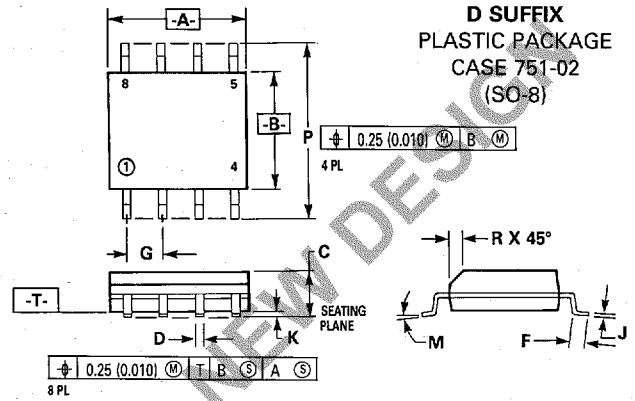

**D SUFFIX
PLASTIC PACKAGE
CASE 751-02
(SO-8)**

- NOTES:
1. DIMENSIONS "A" AND "B" ARE DATUMS AND "T" IS A DATUM SURFACE.
 2. DIMENSIONING AND TOLERANCING PER ANSI Y14.5M, 1982.
 3. CONTROLLING DIM: MILLIMETER.
 4. DIMENSION "A" AND "B" DO NOT INCLUDE MOLD PROTRUSION.
 5. MAXIMUM MOLD PROTRUSION 0.15 (0.006) PER SIDE.

DIM	MILLIMETERS		INCHES	
	MIN	MAX	MIN	MAX
A	4.80	5.00	0.189	0.196
B	3.80	4.00	0.150	0.157
C	1.35	1.75	0.054	0.068
D	0.35	0.49	0.014	0.019
F	0.40	1.25	0.016	0.049
G	1.27 BSC		0.050 BSC	
J	0.19	0.25	0.008	0.009
K	0.10	0.25	0.004	0.009
M	0°	7°	0°	7°
P	5.80	6.20	0.229	0.244
R	0.25	0.50	0.010	0.019

Motorola reserves the right to make changes without further notice to any products herein to improve reliability, function or design. Motorola does not assume any liability arising out of the application or use of any product or circuit described herein; neither does it convey any license under its patent rights nor the rights of others. Motorola and are registered trademarks of Motorola, Inc. Motorola, Inc. is an Equal Employment Opportunity/Affirmative Action Employer.



ARCHIVE DOCUMENT - NOT FOR NEW DESIGN



MOTOROLA Semiconductor Products Inc.

BOX 20912 • PHOENIX, ARIZONA 85036 • A SUBSIDIARY OF MOTOROLA INC.



MOTOROLA SEMICONDUCTORS

P.O. BOX 20912 • PHOENIX, ARIZONA 85036

Advance Information

UNDERVOLTAGE SENSING CIRCUIT

The MC34064 is an undervoltage sensing circuit specifically designed for use as a reset controller in microprocessor-based systems. It offers the designer an economical solution for low voltage detection with a single external resistor. The MC34064 features a trimmed-in-package bandgap reference, and a comparator with precise thresholds and built-in hysteresis to prevent erratic reset operation. The open collector reset output is capable of sinking in excess of 10 mA, and operation is guaranteed down to 1.0 volt input with low standby current. These devices are packaged in 3-pin TO-226AA and 8-pin surface mount packages.

Applications include direct monitoring of the 5.0 volt MPU/logic power supply used in appliance, automotive, consumer and industrial equipment.

- Trimmed-In-Package Temperature Compensated Reference
- Comparator Threshold of 4.6 V at 25°C
- Precise Comparator Thresholds Guaranteed Over Temperature
- Comparator Hysteresis Prevents Erratic Reset
- Reset Output Capable of Sinking in Excess of 10 mA
- Internal Clamp Diode for Discharging Delay Capacitor
- Guaranteed Reset Operation with 1.0 Volt Input
- Low Standby Current
- Economical TO-226AA and SO-8 Surface Mount Packages

REPRESENTATIVE BLOCK DIAGRAM

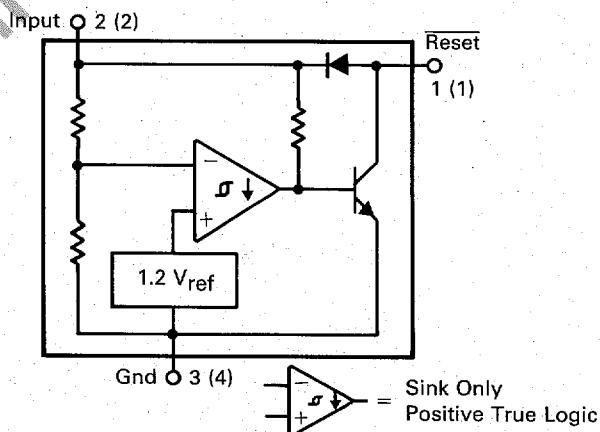

Pin numbers adjacent to terminals are for the 3-pin TO-226AA package.
Pin numbers in parenthesis are for the D suffix SO-8 package.

MC34064 MC33064

UNDERVOLTAGE SENSING CIRCUIT

SILICON MONOLITHIC
INTEGRATED CIRCUIT

P SUFFIX
PLASTIC PACKAGE
CASE 29-04
TO-226AA

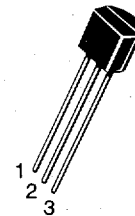

PIN 1. RESET
2. INPUT
3. GROUND

D SUFFIX
PLASTIC PACKAGE
CASE 751-03
SO-8

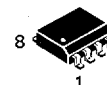

PIN 1. RESET
2. INPUT
3. N.C.
4. GROUND
5. N.C.
6. N.C.
7. N.C.
8. N.C.

ORDERING INFORMATION

Device	Temperature Range	Package
MC34064D-5	0°C to +70°C	Plastic SO-8
MC34064P-5		Plastic TO-226AA
MC33064D-5	-40°C to +85°C	Plastic SO-8
MC33064P-5		Plastic TO-226AA

MAXIMUM RATINGS

Rating	Symbol	Value	Unit
Power Input Supply Voltage	V_{in}	-1.0 to 10	V
Reset Output Voltage	V_O	10	V
Reset Output Sink Current (Note 1)	I_{Sink}	Internally Limited	mA
Clamp Diode Forward Current, Pin 1 to 2 (Note 1)	I_F	100	mA
Power Dissipation and Thermal Characteristics			
P Suffix, Plastic Package			
Maximum Power Dissipation @ $T_A = 25^\circ\text{C}$	P_D	625	mW
Thermal Resistance, Junction to Air	$R_{\theta JA}$	200	$^\circ\text{C/W}$
D Suffix, Plastic Package			
Maximum Power Dissipation @ $T_A = 25^\circ\text{C}$	P_D	625	mW
Thermal Resistance Junction to Air	$R_{\theta JA}$	200	$^\circ\text{C/W}$
Operating Junction Temperature	T_J	+150	$^\circ\text{C}$
Operating Ambient Temperature	T_A		$^\circ\text{C}$
MC34064		0 to +70	
MC33064		-40 to +85	
Storage Temperature Range	T_{stg}	-65 to +150	$^\circ\text{C}$

ELECTRICAL CHARACTERISTICS For typical values $T_A = 25^\circ\text{C}$, for min/max values T_A is the operating ambient temperature range that applies [Notes 2 and 3].

Characteristic	Symbol	Min	Typ	Max	Unit
----------------	--------	-----	-----	-----	------

COMPARATOR

Threshold Voltage					V
High State Output (V_{in} Increasing)	V_{IH}	4.5	4.61	4.7	
Low State Output (V_{in} Decreasing)	V_{IL}	4.5	4.59	4.7	
Hysteresis	V_H	0.01	0.02	0.05	

RESET OUTPUT

Output Sink Saturation	V_{OL}				V
($V_{in} = 4.0\text{ V}$, $I_{Sink} = 8.0\text{ mA}$)		—	0.46	1.0	
($V_{in} = 4.0\text{ V}$, $I_{Sink} = 2.0\text{ mA}$)		—	0.15	0.4	
($V_{in} = 1.0\text{ V}$, $I_{Sink} = 0.1\text{ mA}$)		—	—	0.1	
Output Sink Current (V_{in} , Reset = 4.0 V)	I_{Sink}	10	27	60	mA
Output Off-State Leakage (V_{in} , Reset = 5.0 V)	I_{OH}	—	0.02	0.5	μA
Clamp Diode Forward Voltage, Pin 1 to 2 ($I_F = 10\text{ mA}$)	V_F	0.6	0.9	1.2	V

TOTAL DEVICE

Operating Input Voltage Range	V_{in}	1.0 to 6.5	—	—	V
Quiescent Input Current ($V_{in} = 5.0\text{ V}$)	I_{in}	—	390	500	μA

NOTES:

- Maximum package power dissipation limits must be observed.
- Low duty cycle pulse techniques are used during test to maintain junction temperature as close to ambient as possible.
- $T_{low} = 0^\circ\text{C}$ for MC34064 $T_{high} = +70^\circ\text{C}$ for MC34064
 $\quad = -40^\circ\text{C}$ for MC33064 $\quad = +85^\circ\text{C}$ for MC33064



FIGURE 1 — RESET OUTPUT VOLTAGE versus INPUT VOLTAGE

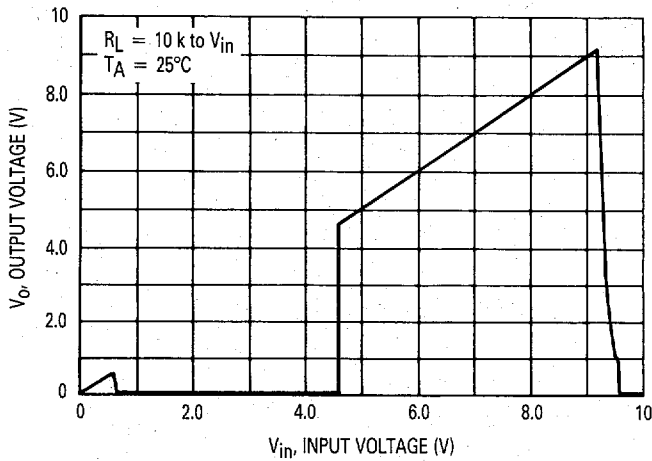

FIGURE 2 — RESET OUTPUT VOLTAGE versus INPUT VOLTAGE

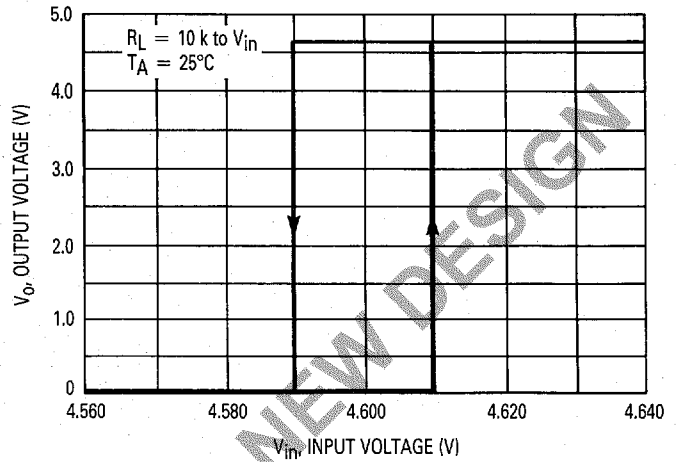

FIGURE 3 — COMPARATOR THRESHOLD VOLTAGE versus TEMPERATURE

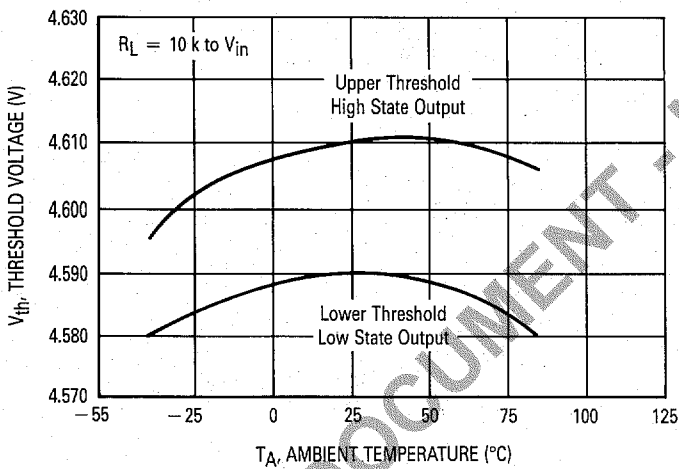

FIGURE 4 — INPUT CURRENT versus INPUT VOLTAGE

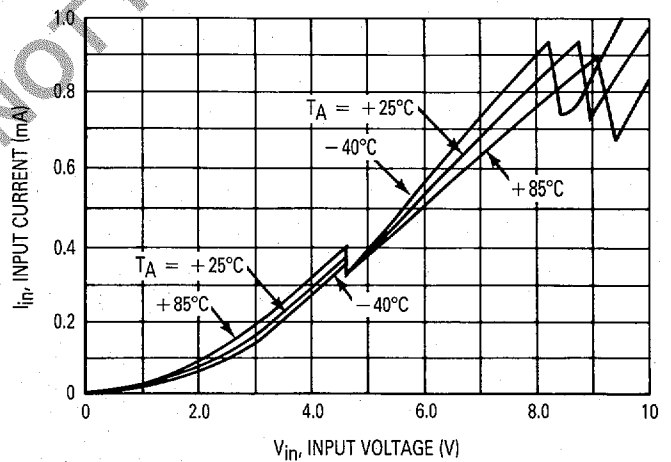

FIGURE 5 — RESET OUTPUT SATURATION versus SINK CURRENT

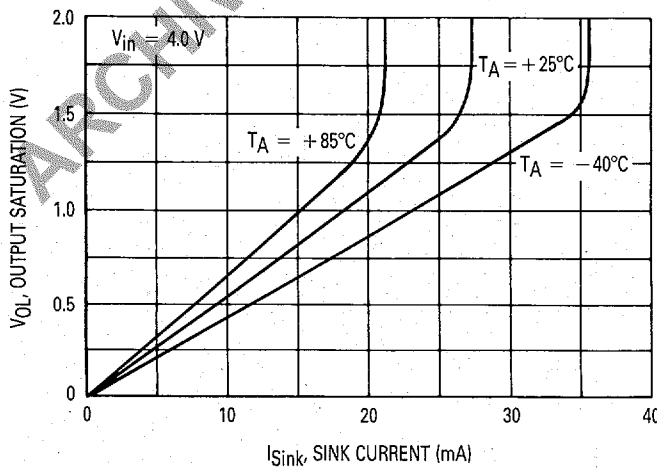

FIGURE 6 — RESET DELAY TIME

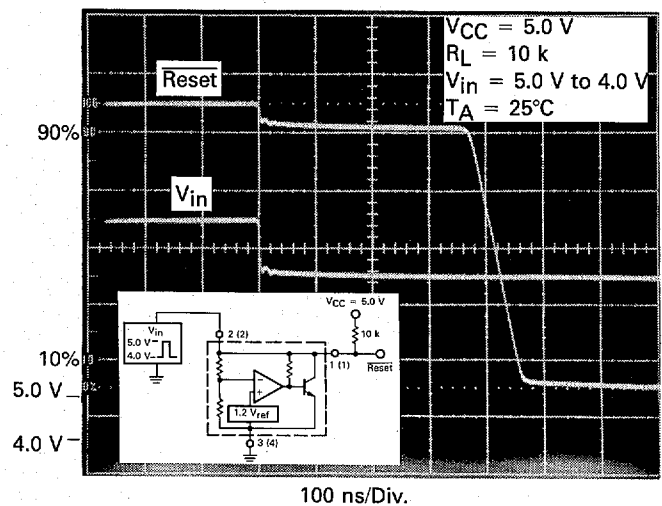

FIGURE 7 — CLAMP DIODE FORWARD CURRENT versus VOLTAGE

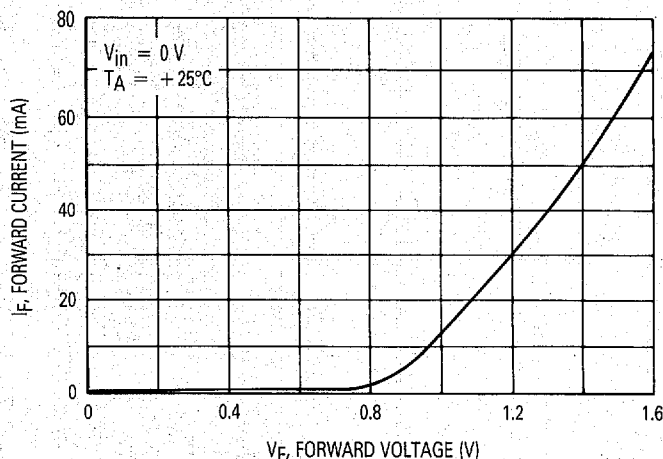
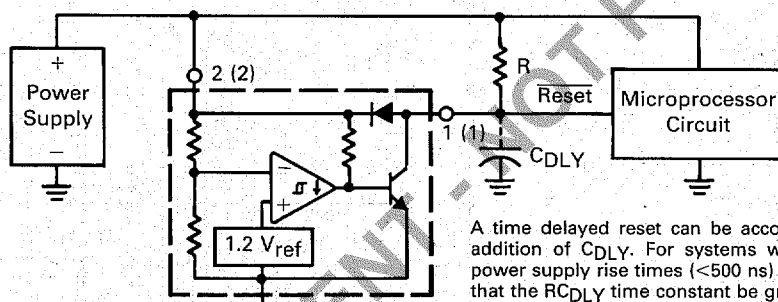

FIGURE 8 — LOW VOLTAGE MICROPROCESSOR RESET



A time delayed reset can be accomplished with the addition of C_{DLY} . For systems with extremely fast power supply rise times (<500 ns) it is recommended that the RC_{DLY} time constant be greater than 5.0 μ s.

$$t_{DLY} = R C_{DLY} \ln \left(\frac{1}{1 - \frac{V_{th}(MPU)}{V_{in}}} \right)$$

FIGURE 9 — LOW VOLTAGE MICROPROCESSOR RESET WITH ADDITIONAL HYSTERESIS

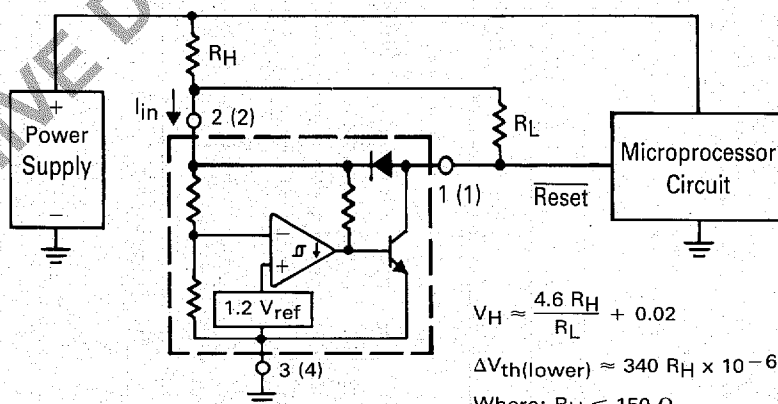

$$V_H \approx \frac{4.6 R_H}{R_L} + 0.02$$

$$\Delta V_{th(lower)} \approx 340 R_H \times 10^{-6}$$

Where: $R_H \leq 150 \Omega$
 $R_L \geq 1.5 k\Omega, \leq 10 k\Omega$

TEST DATA			
V_H (mV)	ΔV_{th} (mV)	R_H (Ω)	R_L (k Ω)
20	0	0	0
51	3.4	10	1.5
40	6.8	20	4.7
81	6.8	20	1.5
71	10	30	2.7
112	10	30	1.5
100	16	47	2.7
164	16	47	1.5
190	34	100	2.7
327	34	100	1.5
276	51	150	2.7
480	51	150	1.5

Comparator hysteresis can be increased with the addition of resistor R_H . The hysteresis equation has been simplified and does not account for the change of input current I_{in} as V_{CC} crosses the comparator threshold (Figure 4). An increase of the lower threshold $\Delta V_{th(lower)}$ will be observed due to I_{in} which is typically 340 μ A at 4.59 V. The equations are accurate to $\pm 10\%$ with R_H less than 150 Ω and R_L between 1.5 k Ω and 10 k Ω .



FIGURE 10 — VOLTAGE MONITOR

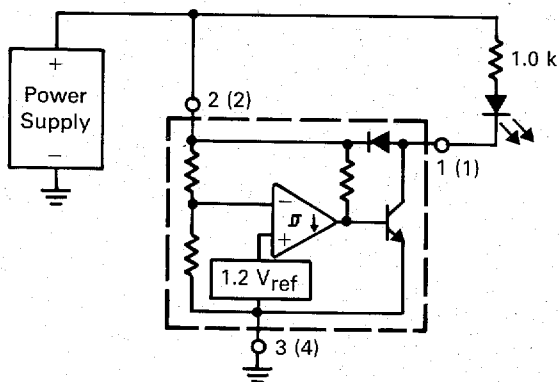

FIGURE 11 — SOLAR POWERED BATTERY CHARGER

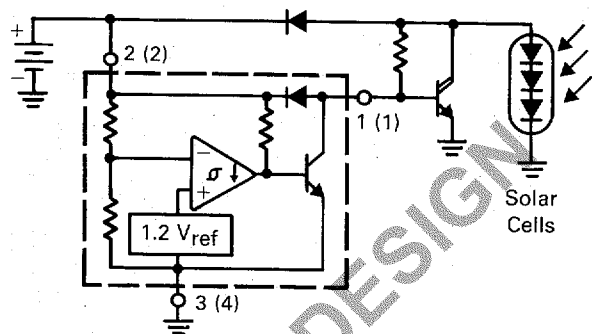
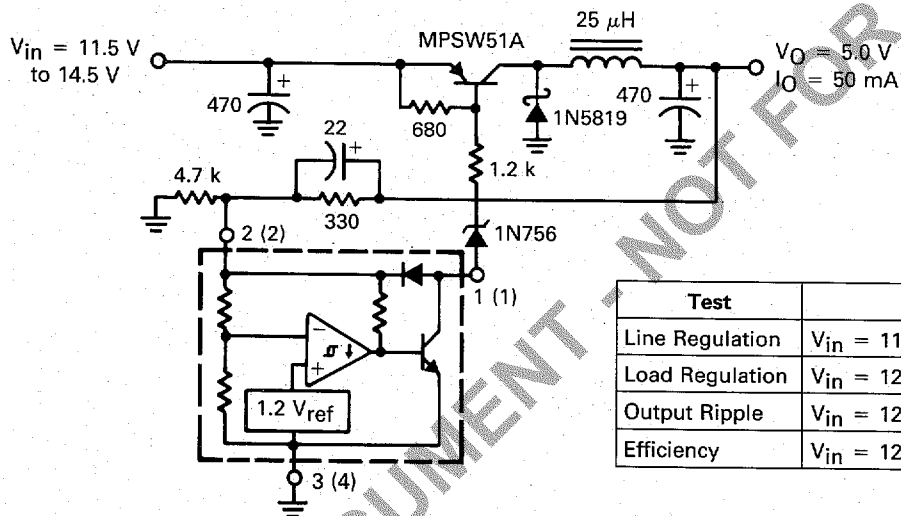
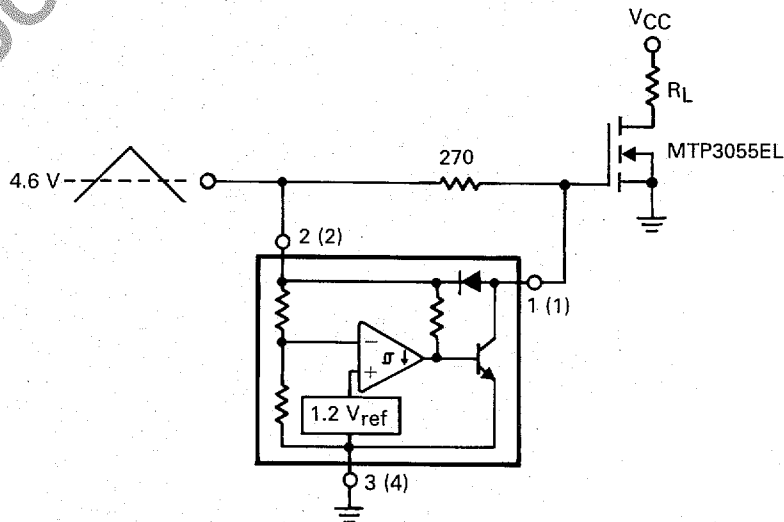

FIGURE 12 — LOW POWER SWITCHING REGULATOR



Test	Conditions	Results
Line Regulation	$V_{in} = 11.5 \text{ V to } 14.5 \text{ V}, I_O = 50 \text{ mA}$	35 mV
Load Regulation	$V_{in} = 12.6 \text{ V}, I_O = 0 \text{ mA to } 50 \text{ mA}$	12 mV
Output Ripple	$V_{in} = 12.6 \text{ V}, I_O = 50 \text{ mA}$	60 mV _{p-p}
Efficiency	$V_{in} = 12.6 \text{ V}, I_O = 50 \text{ mA}$	77%

FIGURE 13 — MOSFET LOW-VOLTAGE GATE DRIVE PROTECTION



Overheating of the logic level power MOSFET due to insufficient gate voltage can be prevented with the above circuit. When the input signal is below the 4.6 volt threshold of the MC34064, its output grounds the gate of the L² MOSFET.



OUTLINE DIMENSIONS

P SUFFIX
PLASTIC PACKAGE
CASE 29-04

NOTES:

1. CONTOUR OF PACKAGE BEYOND ZONE "P" IS UNCONTROLLED.
2. DIM "F" APPLIES BETWEEN "H" AND "L". DIM "D" & "S" APPLIES BETWEEN "L" & 12.70mm (0.5") FROM SEATING PLANE. LEAD DIM IS UNCONTROLLED IN "H" & BEYOND 12.70mm (0.5") FROM SEATING PLANE.
3. CONTROLLING DIM: INCH.

DIM	MILLIMETERS		INCHES	
	MIN	MAX	MIN	MAX
A	4.32	5.33	0.170	0.210
B	4.45	5.20	0.175	0.205
C	3.18	4.19	0.125	0.165
D	0.41	0.55	0.016	0.022
F	0.41	0.48	0.016	0.019
G	1.15	1.39	0.045	0.055
H	—	2.54	—	0.100
J	2.42	2.66	0.095	0.105
K	12.70	—	0.500	—
L	6.35	—	0.250	—
N	2.04	2.66	0.080	0.105
P	2.93	—	0.115	—
R	3.43	—	0.135	—
S	0.39	0.50	0.015	0.020

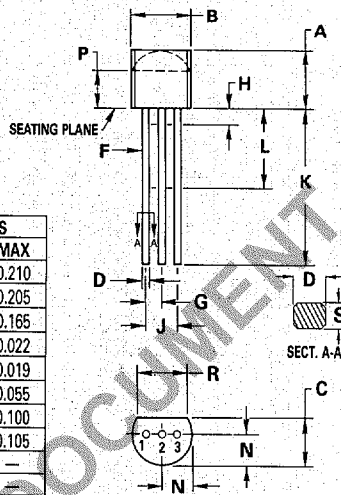

D SUFFIX
PLASTIC PACKAGE
CASE 751-03
(SO-8)

NOTES:

1. DIMENSIONS "A" AND "B" ARE DATUMS AND "T" IS A DATUM SURFACE.
2. DIMENSIONING AND TOLERANCING PER ANSI Y14.5M, 1982.
3. CONTROLLING DIM: MILLIMETER.
4. DIMENSION "A" AND "B" DO NOT INCLUDE MOLD PROTRUSION.
5. MAXIMUM MOLD PROTRUSION 0.15 (0.006) PER SIDE.

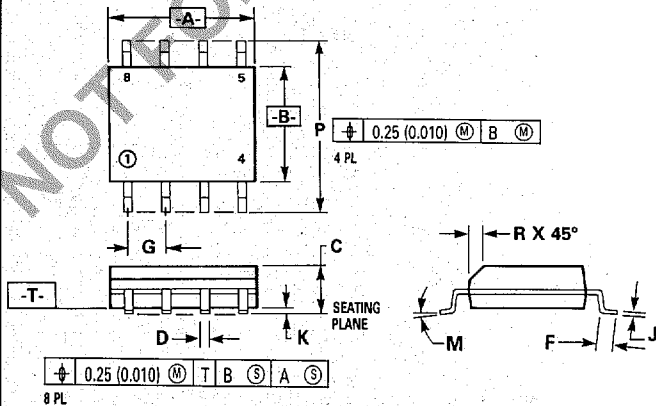

DIM	MILLIMETERS		INCHES	
	MIN	MAX	MIN	MAX
A	4.80	5.00	0.189	0.196
B	3.80	4.00	0.150	0.157
C	1.35	1.75	0.054	0.068
D	0.35	0.49	0.014	0.019
F	0.40	1.25	0.016	0.049
G	1.27	BSC	0.050	BSC
J	0.18	0.25	0.007	0.009
K	0.10	0.25	0.004	0.009
M	0°	7°	0°	7°
P	5.80	6.20	0.229	0.244
R	0.25	0.50	0.010	0.019

Motorola reserves the right to make changes without further notice to any products herein to improve reliability, function or design. Motorola does not assume any liability arising out of the application or use of any product or circuit described herein; neither does it convey any license under its patent rights nor the rights of others. Motorola products are not authorized for use as components in life support devices or systems intended for surgical implant into the body or intended to support or sustain life. Buyer agrees to notify Motorola of any such intended end use whereupon Motorola shall determine availability and suitability of its product or products for the use intended. Motorola and $\text{\textcircled{M}}$ are registered trademarks of Motorola, Inc. Motorola, Inc. is an Equal Employment Opportunity/Affirmative Action Employer.



MOTOROLA Semiconductor Products Inc.

BOX 20912 • PHOENIX, ARIZONA 85036 • A SUBSIDIARY OF MOTOROLA INC.