

This document was generated on 04/23/2010

PLEASE CHECK WWW.MOLEX.COM FOR LATEST PART INFORMATION

Part Number: [0387206218](#)
Status: **Active**
Description: 9.53mm (.375") Pitch Beau™ PCB Terminal Strip, with Mounting Ends, 18 Circuits

Documents:

[3D Model](#) [Product Specification PS-38710-001 \(PDF\)](#)
[Drawing \(PDF\)](#) [RoHS Certificate of Compliance \(PDF\)](#)

General

| | |
|----------------|-----------------------|
| Product Family | Terminal Blocks |
| Series | 38720 |
| Application | Wire-to-Board |
| Component Type | One Piece |
| Product Name | Fixed Mount Barrier |
| Type | Barrier Strip |

Physical

| | |
|--------------------------------|--------------------|
| Circuits (Loaded) | 18 |
| Circuits (maximum) | 18 |
| Color - Resin | Black |
| Entry Angle | Horizontal |
| Lock to Mating Part | None |
| Material - Metal | Brass |
| Material - Plating Mating | Tin |
| Material - Plating Termination | Tin |
| Material - Resin | Polyester |
| Number of Rows | 1 |
| Orientation | Horizontal |
| PC Tail Length (in) | 0.190 In |
| PC Tail Length (mm) | 4.80 mm |
| PCB Retention | Yes |
| PCB Thickness Recommended (in) | 0.125 In |
| PCB Thickness Recommended (mm) | 3.18 mm |
| Panel Mount | No |
| Pitch - Mating Interface (in) | 0.375 In |
| Pitch - Mating Interface (mm) | 9.53 mm |
| Pitch - Term. Interface (in) | 0.375 In |
| Pitch - Term. Interface (mm) | 9.53 mm |
| Plating min: Mating (µin) | 150 |
| Plating min: Mating (µm) | 3.75 |
| Plating min: Termination (µin) | 150 |
| Plating min: Termination (µm) | 3.75 |
| Polarized to Mating Part | No |
| Shrouded | Dual-Barrier |
| Stackable | No |
| Surface Mount Compatible (SMC) | No |
| Temperature Range - Operating | -40°C to +130°C |
| Wire Size AWG | 14, 16, 18, 20, 22 |
| Wire Size mm² | 0.50 - 1.50 |

Electrical

| | |
|-------------------------------|------|
| Current - Maximum per Contact | 15A |
| Voltage - Maximum | 300V |

Solder Process Data

| | |
|------------------------------|------------------------|
| Lead-free Process Capability | Wave Capable (TH only) |
|------------------------------|------------------------|

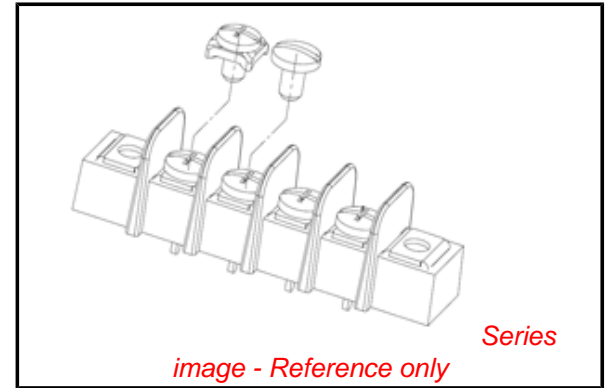

EU RoHS

ELV and RoHS Compliant
REACH SVHC
 Not Reviewed
Halogen-Free Status
Not Reviewed

China RoHS



Need more information on product environmental compliance?

Email productcompliance@molex.com
 For a multiple part number RoHS Certificate of Compliance, [click here](#)

Please visit the [Contact Us](#) section for any non-product compliance questions.

Search Parts in this Series

[38720Series](#)

Mates With

N/A

Material Info

Old Part Number 72518

Reference - Drawing Numbers

Product Specification PS-38710-001

Sales Drawing SD-38720-001

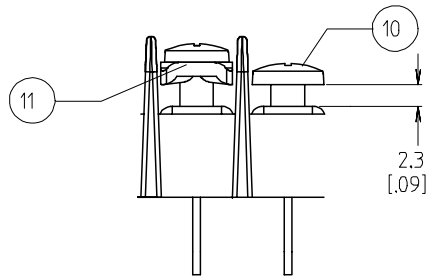
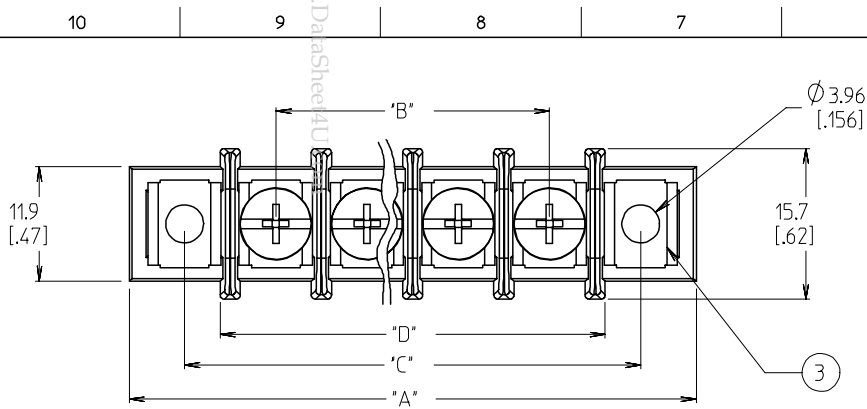

WIRE READY SPEC. (OPTION -47)
(FOR OPTIONAL SCREW -50
AND STANDARD SCREW.)

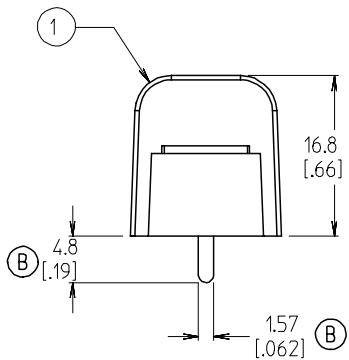
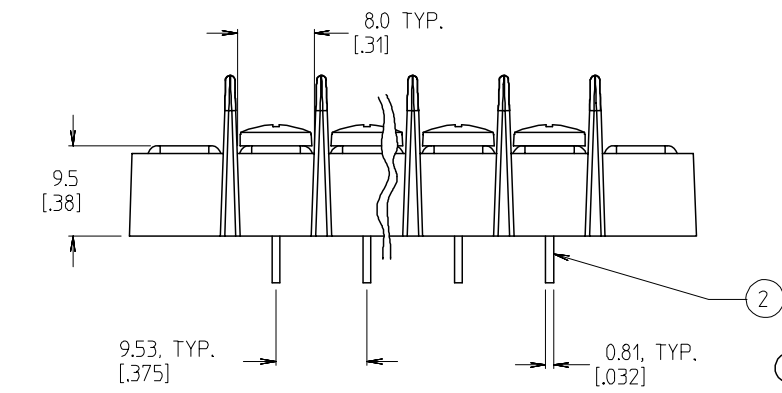

NOTES:

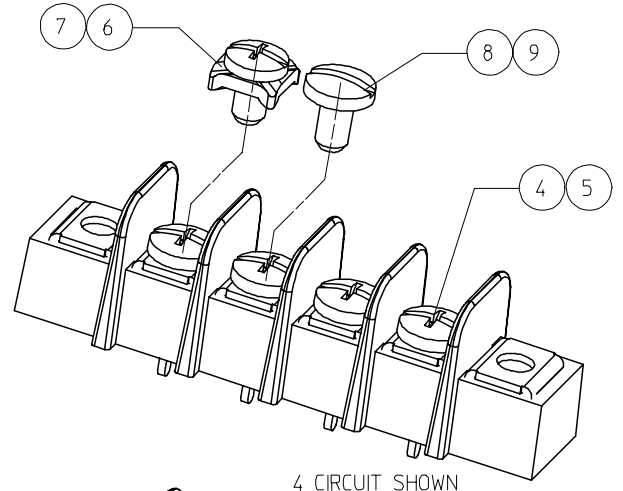

4 CIRCUIT SHOWN

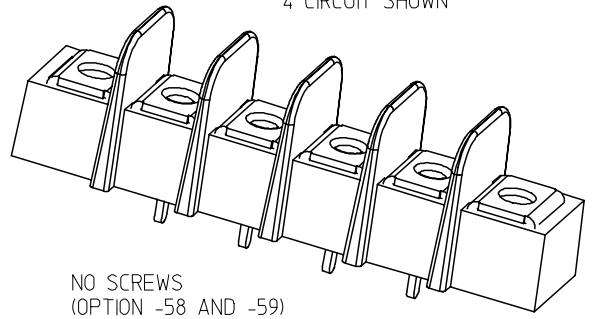

NO SCREWS
(OPTION -58 AND -59)
4 CIRCUIT SHOWN

| | | | | |
|-----|------|----------------------------------|-----------------|--------------------|
| 11 | XX | #6-32 WRDY W/WASH SCR (-47,-50) | STEEL | ZN, CLEAR CHROMATE |
| 10 | XX | #6-32 PH/SLOT WRDY SCR (OPT -47) | STEEL | ZN, CLEAR CHROMATE |
| 9 | XX | #6-32 SLOTTED SCREW (OPT -56) | STAINLESS STEEL | PASSIVATE |
| 8 | XX | #6-32 SLOTTED SCREW (OPT -45) | STEEL | ZN, CLEAR CHROMATE |
| 7 | XX | #6-32 PH/SL W/WASH SCR (-49,-50) | BRASS | NICKEL |
| 6 | XX | #6-32 PH/SL W/WASH SCR (OPT -50) | STEEL | ZN, CLEAR CHROMATE |
| 5 | XX | #6-32 PH/SLOTTED SCREW (OPT -49) | BRASS | NICKEL |
| 4 | XX | #6-32 PH/SLOTTED SCREW (STD) | STEEL | ZN, CLEAR CHROMATE |
| 3 | 2 | MOUNTING PLATE | BRASS | NICKEL |
| 2 | XX | TERMINAL | BRASS | BRT.TIN/CU |
| 1 | 1 | INSULATOR, SINGLE ROW | PBT | BLACK |
| ITE | QTY. | DESCRIPTION | MATERIAL | FINISH |

1. MATERIAL: SEE TABLE
2. FINISHES: SEE TABLE
3. INCH DIMENSIONS ARE IN BRACKETS [XXX].
4. REFER TO SD-38120-001 FOR IMPRINTING OPTIONS 10A AND 11A.
5. REFER TO SD-38120-007 FOR IMPRINTING OPTION 12A.
6. "XX" REFERS TO THE QUANTITY OF CIRCUITS.
7. ALL COMPONENTS ARE ROHS COMPLIANT.

ADD. MAT. NO.
EC NO: ETC2007-0166
DRWN: CLYORK 2006/10/19
CHKD: JMACEIL 2006/10/20
APPR: JMACEIL 2006/10/20

QUALITY SYMBOLS

| GENERAL TOLERANCES (UNLESS SPECIFIED) | |
|---------------------------------------|---------|
| | MM |
| 4 PLACES | ± 0.13 |
| 3 PLACES | ± 0.10 |
| 2 PLACES | ± 0.075 |
| 1 PLACE | ± 0.05 |
| ANGULAR ± 2 ° | |

| DIMENSION STYLE | |
|-----------------|------------------------|
| MM/IN | SCALE |
| 2:1 | DESIGN UNITS |
| INCH | THIRD ANGLE PROJECTION |
| DRAWN BY | DATE |
| W. HOWARD | 2003/10/16 |
| CHECKED BY | DATE |
| R. KEMP | 2003/10/16 |
| APPROVED BY | DATE |
| P. WALTZ | 2003/10/16 |
| MATERIAL NO. | DOCUMENT NO. |
| SEE SHT. 2 | SD-38720-001 |

| | | | |
|--------------|--|-------------------------------|--|
| TITLE | | 9.53MM [.375] SR BTS, PC ASSY | |
| MATERIAL NO. | | SD-38720-001 | |
| DOCUMENT NO. | | SHEET NO. | |
| SEE SHT. 2 | | 1 OF 2 | |

THIS DRAWING CONTAINS INFORMATION THAT IS PROPRIETARY TO MOLEX INCORPORATED AND SHOULD NOT BE USED WITHOUT WRITTEN PERMISSION

| MATERIAL NO. (OPT 12A) | MATERIAL NO. (OPT 11A) | MATERIAL NO. (OPT 10A) | MATERIAL NO. (OPT -59) | MATERIAL NO. (OPT -58) | MATERIAL NO. (OPT -56) | MATERIAL NO. (OPT -50) | MATERIAL NO. (OPT -49,-50) | MATERIAL NO. (OPT -49) | MATERIAL NO. (OPT -47,-50) | MATERIAL NO. (STD) | NUMBER OF CIRCUITS 'XX' |
|------------------------|------------------------|------------------------|------------------------|------------------------|------------------------|------------------------|----------------------------|------------------------|----------------------------|--------------------|-------------------------|
| | | | | | 38729-0659 | 38729-0791 | 38729-1381 | 38729-6802 | | 38729-6201 | 01 |
| | | 38729-1039 | | 38729-0750 | 38729-0791 | 38729-7402 | | | | 38729-6202 | 02 |
| 38729-0872 | 38729-0025 | 38729-0014 | | | 38729-0117 | 38729-7403 | | 38729-6803 | 38729-8603 | 38729-6203 | 03 |
| | | 38729-0940 | 38729-0945 | | 38729-0839 | 38729-7404 | 38729-1159 | 38729-6804 | | 38729-6204 | 04 |
| 38729-0256 | | 38729-0346 | | | 38729-1253 | 38729-7405 | 38729-1382 | 38729-6805 | | 38729-6205 | 05 |
| | | | 38729-0400 | 38729-0386 | 38729-0980 | 38729-7406 | 38729-1383 | 38729-6806 | | 38729-6206 | 06 |
| | | | 38729-0423 | 38729-0407 | 38729-0435 | 38729-0440 | 38729-7407 | 38729-6807 | | 38729-6207 | 07 |
| 38729-0497 | | | | | 38729-0508 | 38729-0532 | 38729-7408 | 38729-6808 | | 38729-6208 | 08 |
| | | 38729-0548 | | | 38729-0560 | | 38729-7409 | 38729-6809 | | 38729-6209 | 09 |
| | | 38729-1011 | 38729-0598 | 38729-0598 | | | 38729-7410 | 38729-6810 | | 38729-6210 | 10 |
| | | | | | 38729-1252 | 38729-7411 | | | | 38729-6211 | 11 |
| | | 38729-0720 | | | 38729-0735 | 38729-7412 | | 38729-6812 | | 38729-6212 | 12 |
| | | | | 38729-0809 | | 38729-7413 | | | | 38729-6213 | 13 |
| | | | | 38729-0004 | | 38729-7414 | | 38729-6814 | | 38729-6214 | 14 |
| | | | | | | | | | | 38729-6215 | 15 |
| | | | | | | | | | | 38729-6216 | 16 |
| | | | | | | | | | | 38729-6217 | 17 |
| | | | | | | | | | | 38729-6218 | 18 |
| | | | | | | | | | | 38729-6219 | 19 |
| | | | | | | | | | | 38729-6220 | 20 |
| | | | | | | | | | | 38729-6221 | 21 |
| | | | | | | | | | | 38729-6222 | 22 |
| | | | | | | | | | | 38729-6223 | 23 |
| | | | | | | | | | | 38729-6224 | 24 |
| | | | | | | | | | | 38729-6225 | 25 |
| | | | | | | | | | | 38729-6226 | 26 |

| NUMBER OF CIRCUITS 'XX' | DIM. 'A' | | DIM. 'B' | | DIM. 'C' | | DIM. 'D' | |
|-------------------------|----------|---------|----------|---------|----------|---------|----------|--------|
| 01 | 30.7 | [.121] | - | - | 19.1 | [.75] | 11.6 | [.46] |
| 02 | 40.1 | [.158] | 9.53 | [.375] | 28.6 | [1.13] | 21.1 | [.83] |
| 03 | 49.7 | [.196] | 19.05 | [.750] | 38.1 | [1.50] | 30.6 | [1.21] |
| 04 | 59.2 | [.233] | 28.58 | [1.125] | 47.6 | [1.88] | 40.1 | [1.58] |
| 05 | 68.7 | [.271] | 38.10 | [1.500] | 57.2 | [2.25] | 49.7 | [1.96] |
| 06 | 78.2 | [.308] | 47.63 | [1.875] | 66.7 | [2.63] | 59.2 | [2.33] |
| 07 | 87.8 | [.346] | 57.15 | [2.250] | 76.2 | [3.00] | 68.7 | [2.71] |
| 08 | 97.3 | [.383] | 66.68 | [2.625] | 85.7 | [3.38] | 78.2 | [3.08] |
| 09 | 106.8 | [.421] | 76.20 | [3.000] | 95.3 | [3.75] | 87.8 | [3.46] |
| 10 | 116.3 | [.458] | 85.73 | [3.375] | 104.8 | [4.13] | 97.3 | [3.83] |
| 11 | 125.9 | [.496] | 95.25 | [3.750] | 114.3 | [4.50] | 106.8 | [4.21] |
| 12 | 135.4 | [.533] | 104.78 | [4.125] | 123.8 | [4.88] | 116.3 | [4.58] |
| 13 | 144.9 | [.571] | 114.30 | [4.500] | 133.4 | [5.25] | 125.9 | [4.96] |
| 14 | 154.4 | [.608] | 123.83 | [4.875] | 142.9 | [5.63] | 135.4 | [5.33] |
| 15 | 164.0 | [.646] | 133.35 | [5.250] | 152.4 | [6.00] | 144.9 | [5.71] |
| 16 | 173.5 | [.683] | 142.88 | [5.625] | 161.9 | [6.38] | 154.4 | [6.08] |
| 17 | 183.0 | [.721] | 152.40 | [6.000] | 171.5 | [6.75] | 164.0 | [6.46] |
| 18 | 192.5 | [.758] | 161.93 | [6.375] | 181.0 | [7.13] | 173.5 | [7.21] |
| 19 | 202.1 | [.796] | 171.45 | [6.750] | 190.5 | [7.50] | 192.5 | [7.58] |
| 20 | 211.6 | [.833] | 180.98 | [7.125] | 200.0 | [7.88] | 202.1 | [7.96] |
| 21 | 221.1 | [.871] | 190.50 | [7.500] | 209.6 | [8.25] | 211.6 | [8.33] |
| 22 | 230.6 | [.908] | 200.03 | [7.875] | 219.1 | [8.63] | 221.1 | [8.71] |
| 23 | 240.2 | [.946] | 209.55 | [8.250] | 228.6 | [9.00] | 230.6 | [9.08] |
| 24 | 249.7 | [.983] | 219.08 | [8.625] | 238.1 | [9.38] | 230.6 | [9.08] |
| 25 | 259.2 | [10.21] | 228.60 | [9.000] | 247.7 | [9.75] | 240.2 | [9.46] |
| 26 | 268.7 | [10.58] | 238.13 | [9.375] | 257.2 | [10.13] | 249.7 | [9.83] |

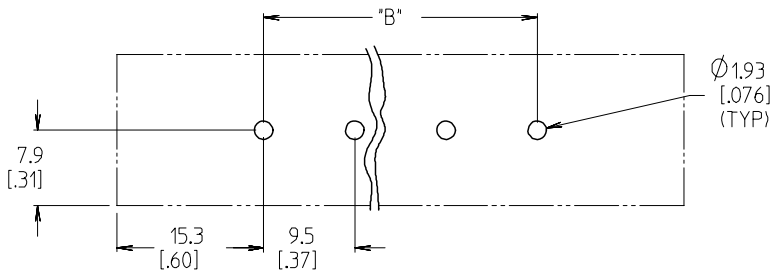

PTH PATTERN

| | | | | | | |
|---|---|--|---|--|---|------------------------|
| SEE SHEET 1 EC NO: ETC2007-0166 DRW: NCLYORK 2006/10/19 CHKD: JMACNEIL 2006/10/20 APPR: JMACNEIL 2006/10/20 | QUALITY SYMBOLS ▽=0 ▽=0 | GENERAL TOLERANCES (UNLESS SPECIFIED) | DIMENSION STYLE MM/IN | SCALE 2:1 | DESIGN UNITS INCH | THIRD ANGLE PROJECTION |
| | | 4 PLACES ± --- ± --- 3 PLACES ± --- ± .005 2 PLACES ± 0.13 ± .01 1 PLACE ± 0.3 ± --- ANGULAR ± 2 ° | DRAWN BY W. HOWARD DATE 2003/10/16 CHECKED BY R. KEMP DATE 2003/10/16 APPROVED BY P. WALTZ DATE 2003/10/16 | TITLE 9.53MM [.375] SR BTS, PC ASSY | MOLEX MOLEX INCORPORATED DOCUMENT NO. SD-38720-001 | |
| DRAFT WHERE APPLICABLE MUST REMAIN WITHIN DIMENSIONS | SIZE B THIS DRAWING CONTAINS INFORMATION THAT IS PROPRIETARY TO MOLEX INCORPORATED AND SHOULD NOT BE USED WITHOUT WRITTEN PERMISSION | | | | | |