

EntréPad[®] AES2500

Fingerprint Sensor

PRELIMINARY

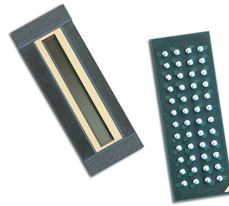

AuthenTec, Inc.
Personal Security for the Real World™

Introducing...

The all-new EntréPad AES2500 slide sensor is AuthenTec's latest and lowest cost fingerprint sensor. AuthenTec has adapted its patented, award winning TruePrint[®] technology to read fingerprints while the finger is pulled across the AES2500's rectangular surface. In this manner, the full fingerprint is acquired while the sensor is substantially reduced in size.

The AES2500 combines silicon-based image capture with proprietary sensor control and matching algorithms to provide the best quality lowest cost biometric authentication solution available.

TruePrint Is...

AuthenTec's unique, patented imaging technology adapted for sliding finger motion. All of AuthenTec's EntréPad and FingerLoc[®] sensors utilize TruePrint technology, enabling the sensor to look past the easily obscured outer surface of the skin to the living layer below where the unique ridge and valley patterns of the fingerprint originate.

A powerful component of TruePrint is Dynamic Optimization which is built directly into the sensor and allows the AES2500 to deliver multiple images of the fingerprint (called image slices) as the finger is pulled across the sensor. Each image slice is analyzed real-time, with up to 15 parameters adjusted to optimize image quality, or surface contamination.

High Performance...

- ▶ TruePrint for sliding fingers
- ▶ >11cm/sec finger slide speed
- ▶ Unequaled "Ability to Acquire"
- ▶ Industry's best FAR/FRR
- ▶ Security Features
- ▶ 5-way Navigation

Ultra-Small Form Factor...

- ▶ 48 Ball Grid Array (BGA)
- ▶ 13.8mm x 5mm x 1.3mm

Robust Packaging...

- ▶ Scratch and impact resistant
- ▶ (stress-tested to >40,000 psi)
- ▶ Rub-resistant to >1M rubs
- ▶ Impervious to contamination

Detection Matrix...

- ▶ 192 x 16 pixels
- ▶ 9.75mm x 0.81mm
- ▶ 500 ppi high-resolution images

SelectaBus...

- ▶ Asynchronous serial interface
- ▶ 2Mbps synchronous serial and
- ▶ USB 2.0 Full Speed

Operating Voltage Range...

- ▶ 2.4V - 3.6V

Commercial Temp. Range...

- ▶ 0°C through +70°C

Current Consumption @ 2.5V...

- ▶ Advanced power management
- ▶ 30mA peak imaging
- ▶ 3mA hardware finger detect
- ▶ 300uA navigation mode

High-Rate Image Capture...

- ▶ Up to 162 frames/second

ESD Resistance...

- ▶ IEC 61000-4-2 Level 4 (±15KV)

Supported Operating Systems...

- ▶ Microsoft[®] Windows 98[®], ME[®], 2000[®], XP[®], and NT[®] v4.0
- ▶ Symbian[®], CE 3.0[®]



Superior Image Quality...

TruePrint high-quality fingerprint imaging technology makes possible the most reliable authentication. High quality imaging ensures that we can capture everyone's fingerprint, every time under virtually all conditions.

Target Applications...

The EntréPad AES2500 is specifically designed and optimized for use in mobile devices such as cell phones, PDA's, smart displays, and other small form-factor products. Its extremely low price, ultra small size, and low power requirements convenient access.

Convenient Security...

The EntréPad AES2500 fingerprint sensor features hardware finger detection capability and specialized security features for system integrity. With the new 5 way navigation functions on-chip, the AES2500 facilitates seamless menu navigation and scrolling with no additional hardware required.

Authentication Solution Cost...

The AES2500 is AuthenTec's answer authentication requirements where minimizing cost is paramount. AuthenTec remains committed to providing the lowest overall cost of authentication in any configuration with the widest range of fingerprint sensors.

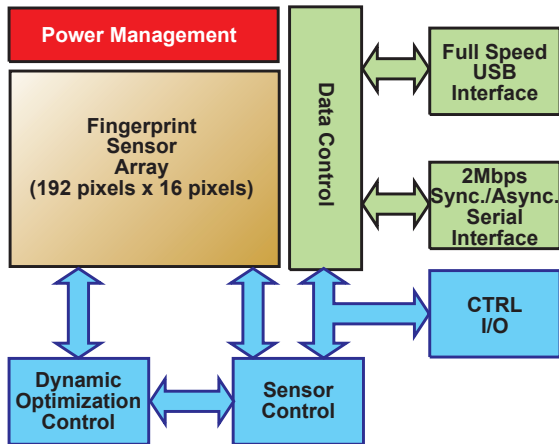

The EntréPad AES2500 sensor incorporates flexible SelectaBus architecture. This feature allows the developer to deploy designs that use the popular Universal Serial Bus (USB), Synchronous Serial or Asynchronous interfaces.

- ▶ USB Version 2.0 full speed
- ▶ Synchronous & Asynchronous Serial @ 2Mbps
- ▶ Bus choice is pin-selectable
- ▶ Advanced biometric power management system
- ▶ High data throughput rates permit fast finger motion to over 11cm/sec slide rate

With SelectaBus, several solutions can be served by a single SKU, simplifying procurement and inventory management.

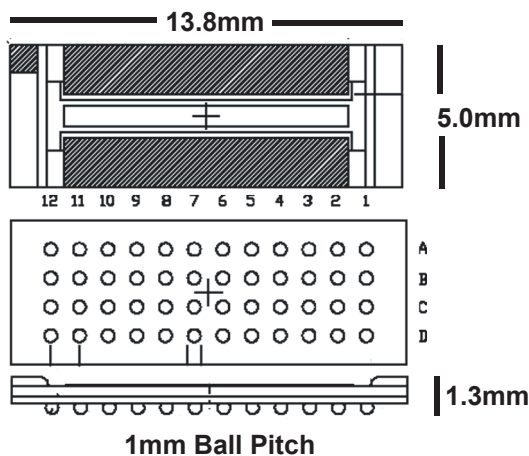

The form factor of the EntréPad AES2500 is 48 BGA

In addition to AuthenTec's latest sensor, let us introduce you to the AuthenTec family of kits...

AuthenTec provides a full range of hardware, software, and support for easy integration. This includes advanced sensor control and fingerprint matching algorithms, device driver support for Windows XP, 2000, ME, 98, and NT v4.0, plus Windows embedded support* (CE .Net, PocketPC 2002, & Smartphone 2002), Symbian* and Palm OS5.0*. Support is also provided for industry-standard biometric Applications Programming Interfaces (APIs). All these features are conveniently bundled into kits:

- ▶ Technology Evaluation Kits (TEKs) are low cost introductory tools that come complete with a sensor module, matching algorithms, and demonstration software. TEKs enable quick and easy investigation of our technology.
- ▶ Software Developer's Kits (SDKs) are available for Independent Software Vendors (ISVs) who wish to develop products that interface with AuthenTec sensors.
- ▶ Reference Design Kits (RDks) enable manufacturers of PCs, peripherals, PDA's, and wireless devices to quickly integrate AuthenTec sensors into their products.
- ▶ * "OS Ready" Operating System Support enables AuthenTec to quickly provide dedicated software drivers in support of unique customer hardware platforms. The major work in preparing the necessary drivers has already been completed. Contact AuthenTec directly for more information regarding this support.

For more information contact AuthenTec or your local AuthenTec representative.

AuthenTec, Inc.

P. O. Box 2719
Melbourne, FL
32902-2719 U.S.A.
321-308-1300 (phone)
321-308-1430 (fax)
www.authentec.com
info@authentec.com