

ISP1760

Hi-Speed Universal Serial Bus host controller for embedded applications

Rev. 01 — 8 November 2004

Product data sheet

1. General description

The ISP1760 is a Hi-Speed Universal Serial Bus (USB) Host Controller with a generic processor interface. It integrates one Enhanced Host Controller Interface (EHCI), one Transaction Translator (TT) and three transceivers. The Host Controller portion of the ISP1760 and the three transceivers comply to *Universal Serial Bus Specification Rev. 2.0*. The EHCI portion of the ISP1760 is adapted from *Enhanced Host Controller Interface Specification for Universal Serial Bus Rev. 1.0*.

The integrated high-performance Hi-Speed USB transceivers enable the ISP1760 to handle all Hi-Speed USB transfer speed modes: high-speed (480 Mbit/s), full-speed (12 Mbit/s) and low-speed (1.5 Mbit/s). The three downstream ports allow simultaneous connection of three devices at different speeds (high-speed, full-speed and low-speed).

The generic processor interface allows the ISP1760 to be connected to various processors as a memory-mapped resource. The ISP1760 is a slave host: it does not require 'bus-mastering' capabilities of the host system bus. The interface is configurable, ensuring compatibility with a variety of processors. Data transfer can be performed on 16 bits or 32 bits, using Programmed Input/Output (PIO) or Direct Memory Access (DMA) with major control signals configurable as active LOW or active HIGH.

Integration of the TT allows connection to full-speed and low-speed devices, without the need of integrating Open Host Controller Interface (OHCI) or Universal Host Controller Interface (UHCI). Instead of dealing with two sets of software drivers—EHCI and OHCI or UHCI—you need to deal with only one set—EHCI—that dramatically reduces software complexity and IC cost.

2. Features

- The Host Controller portion of the ISP1760 complies with *Universal Serial Bus Specification Rev. 2.0*
- The EHCI portion of the ISP1760 is adapted from *Enhanced Host Controller Interface Specification for Universal Serial Bus Rev. 1.0*
- Contains three integrated Hi-Speed transceivers that support the high-speed, full-speed and low-speed modes
- Integrates a TT for Original USB (full-speed and low-speed) device support
- Up to 64-kbyte internal memory (8 k x 64 bits) accessible through a generic processor interface; operation in multitasking environments is made possible by the implementation of virtual segmentation mechanism with bank switching on task request

PHILIPS

- Generic processor interface (nonmultiplexed and variable latency) with a configurable 32-bit or 16-bit external data bus; the processor interface can be defined as variable-latency or SRAM type (memory mapping)
- Slave DMA support for reducing the load of the host system CPU during the data transfer to or from the memory
- Integrated phase-locked loop (PLL) with a 12 MHz crystal or an external clock input
- Integrated multiconfiguration FIFO
- Optimized 'msec-based' or 'multi-msec-based' Philips Transfer Descriptor (PTD) interrupt
- Tolerant I/O for low voltage CPU interface (1.65 V to 3.6 V)
- 3.3 V-to-5.0 V external power supply input
- Integrated 5.0 V-to-1.8 V or 3.3 V-to-1.8 V voltage regulator (internal 1.8 V for low-power core)
- Internal power-on reset and low-voltage reset
- Supports suspend and remote wake-up
- Target current consumption:
 - ◆ Normal operation; one port in high-speed active: $I_{CC} < 100$ mA
 - ◆ Suspend mode: $I_{SUSP} < 150$ μ A at the room temperature
- Built-in configurable overcurrent circuitry (digital or analog overcurrent protection)
- Available in LQFP128 package.

3. Applications

The ISP1760 can be used to implement a Hi-Speed USB compliant Host Controller connected to most of the CPUs present in the market today, having a generic processor interface with demultiplexed address and data bus. This is because of the efficient slave-type interface of the ISP1760.

The internal architecture of the ISP1760 is such that it can be used in a large spectrum of applications requiring a high-performance internal Host Controller.

3.1 Examples of a multitude of possible applications

- Set-top box: for connecting external high-performance mass storage devices
- Mobile phone: for connecting various USB devices
- Personal Digital Assistant (PDA): for connecting a large variety of USB devices
- Printer: for connecting external memory card readers, allowing direct printing
- Digital Still Camera (DSC): for printing to an external USB printer, for direct printing
- Mass storage: for connecting external memory card readers or other mass storage devices, for direct back-up.

The low power consumption and deep power management modes of the ISP1760 make it particularly suitable for use in portable devices.

4. Ordering information

Table 1: Ordering information

Type number	Package		
	Name	Description	Version
ISP1760BE	LQFP128	plastic low profile quad flat package; 128 leads; body 14 x 20 x 1.4 mm	SOT425-1

5. Block diagram

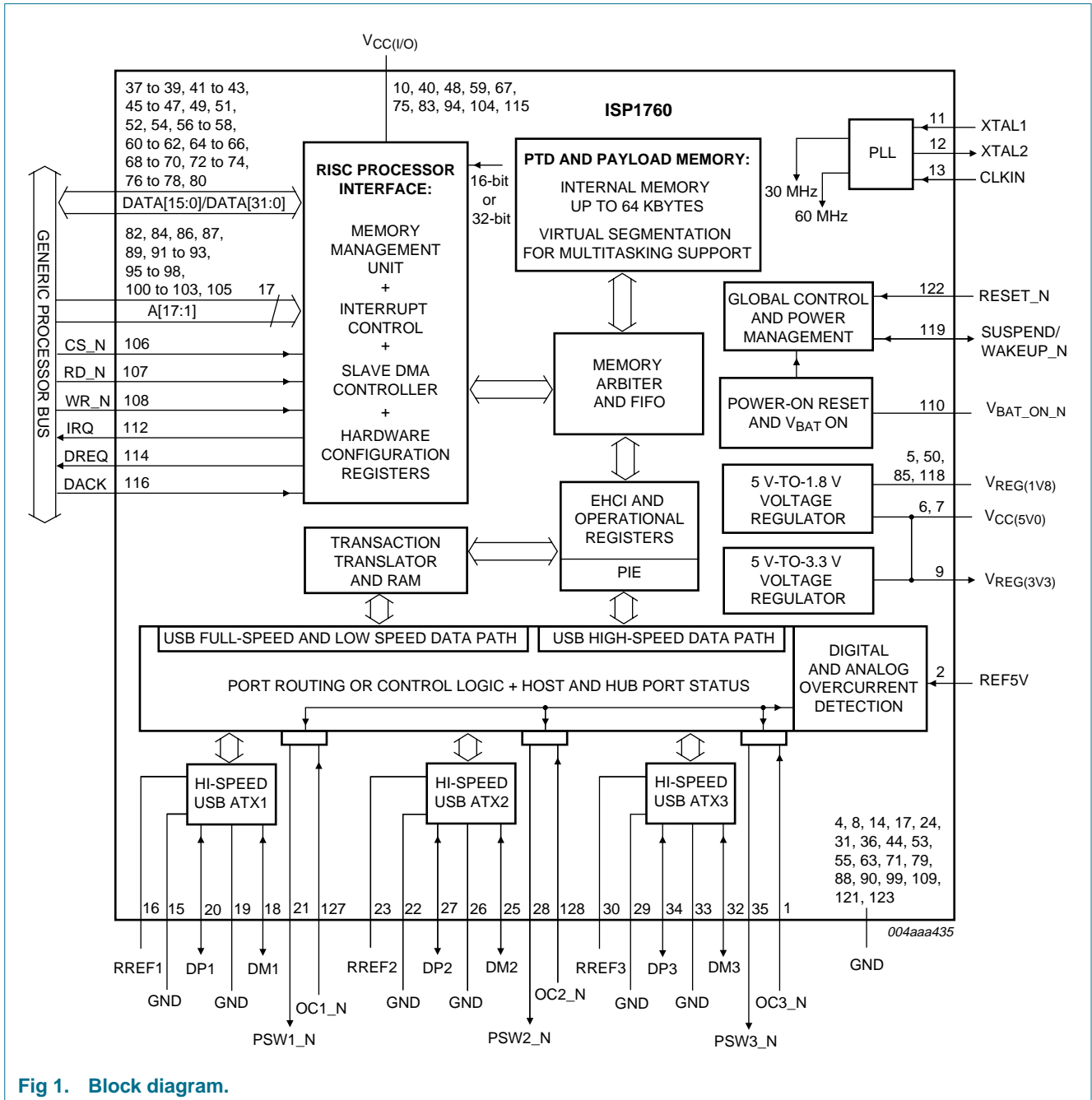

Fig 1. Block diagram.

6. Pinning information

6.1 Pinning

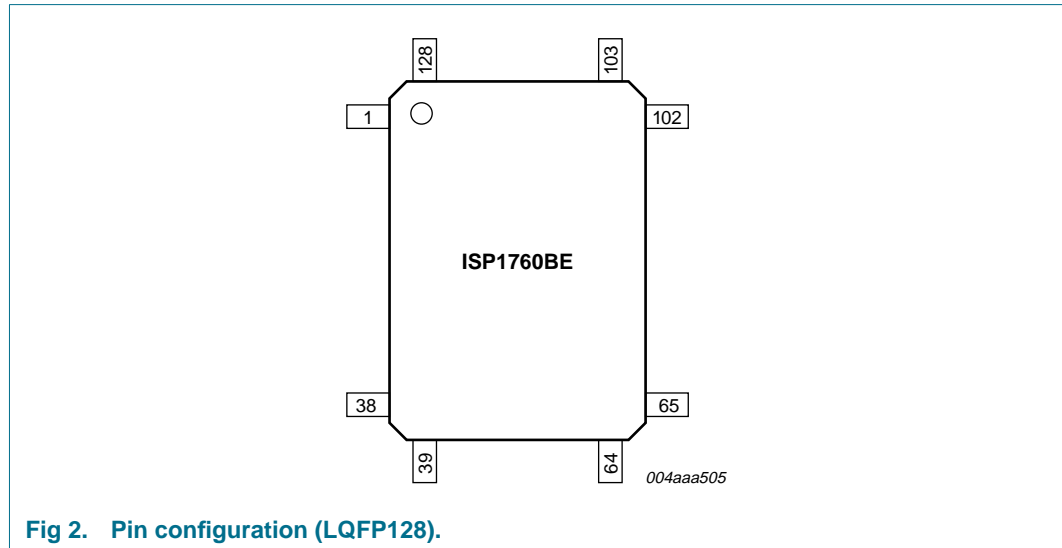

Fig 2. Pin configuration (LQFP128).

6.2 Pin description

Table 2: Pin description

Symbol [1]	Pin	Type [2]	Description
OC3_N	1	AI	port 3 analog (5 V input) and digital overcurrent input; if not used, connect to $V_{CC(I/O)}$ through a 10 k Ω resistor
REF5V	2	AI	5 V reference input for analog OC detector; connect a 100 nF decoupling capacitor
TEST	3	-	connect to ground
GND	4	-	analog ground
$V_{REG(1V8)}$	5	P	core power output (1.8 V); internal 1.8 V for the digital core; used for decoupling; connect a 100 nF capacitor
$V_{CC(5V0)}$	6	P	input to internal regulators (3.0 V to 5.5 V); connect a 100 nF decoupling capacitor
$V_{CC(5V0)}$	7	P	input to internal regulators (3.0 V to 5.5 V); connect a 100 nF decoupling capacitor
GND	8	-	oscillator ground
$V_{REG(3V3)}$	9	P	regulator output (3.3 V); for decoupling only; connect a 100 nF capacitor and a 4.7 μ F to 10 μ F capacitor
$V_{CC(I/O)}$	10	P	digital supply; 1.65 V to 3.6 V; connect a 100 nF decoupling capacitor
XTAL1	11	AI	12 MHz crystal connection input; connect to ground if an external clock is used; see Table 84
XTAL2	12	AO	12 MHz crystal connection output
CLKIN	13	I	12 MHz oscillator or clock input; connect to $V_{CC(I/O)}$ when not in use 3.3 V tolerant
GND	14	-	digital ground

Table 2: Pin description...continued

Symbol [1]	Pin	Type [2]	Description
GND	15	-	RREF1 ground
RREF1	16	AI	reference resistor connection; connect a $12\text{ k}\Omega \pm 1\%$ resistor between this pin and the RREF1 ground
GND	17	-	analog ground for port 1
DM1	18	AI/O	downstream data minus port 1
GND	19	-	analog ground
DP1	20	AI/O	downstream data plus port 1
PSW1_N	21	OD	power switch port 1, active LOW output pad, push-pull open-drain, 8 mA output drive, 5 V tolerant
GND	22	-	RREF2 ground
RREF2	23	AI	reference resistor connection; connect a $12\text{ k}\Omega \pm 1\%$ resistor between this pin and the RREF2 ground
GND	24	-	analog ground for port 2
DM2	25	AI/O	downstream data minus port 2
GND	26	-	analog ground
DP2	27	AI/O	downstream data plus port 2
PSW2_N	28	OD	power switch port 2, active LOW output pad, push-pull open-drain, 8 mA output drive, 5 V tolerant
GND	29	-	RREF3 ground
RREF3	30	AI	reference resistor connection; connect a $12\text{ k}\Omega \pm 1\%$ resistor between this pin and the RREF3 ground
GND	31	-	analog ground for port 3
DM3	32	AI/O	downstream data minus port 3
GND	33	-	analog ground
DP3	34	AI/O	downstream data plus port 3
PSW3_N	35	OD	power switch port 3, active LOW output pad, push-pull open-drain, 8 mA output drive, 5 V tolerant
GND	36	-	digital ground
DATA0	37	I/O	data bit 0 input and output bidirectional pad, push-pull input, three-state output, 4 mA output drive, 3.3 V tolerant
DATA1	38	I/O	data bit 1 input and output bidirectional pad, push-pull input, three-state output, 4 mA output drive, 3.3 V tolerant
DATA2	39	I/O	data bit 2 input and output bidirectional pad, push-pull input, three-state output, 4 mA output drive, 3.3 V tolerant
$V_{CC(I/O)}$	40	P	digital supply; 1.65 V to 3.6 V; connect a 100 nF decoupling capacitor
DATA3	41	I/O	data bit 3 input and output bidirectional pad, push-pull input, three-state output, 4 mA output drive, 3.3 V tolerant

Table 2: Pin description...continued

Symbol [1]	Pin	Type [2]	Description
DATA4	42	I/O	data bit 4 input and output bidirectional pad, push-pull input, three-state output, 4 mA output drive, 3.3 V tolerant
DATA5	43	I/O	data bit 5 input and output bidirectional pad, push-pull input, three-state output, 4 mA output drive, 3.3 V tolerant
GND	44	-	digital ground
DATA6	45	I/O	data bit 6 input and output bidirectional pad, push-pull input, three-state output, 4 mA output drive, 3.3 V tolerant
DATA7	46	I/O	data bit 7 input and output bidirectional pad, push-pull input, three-state output, 4 mA output drive, 3.3 V tolerant
DATA8	47	I/O	data bit 8 input and output bidirectional pad, push-pull input, three-state output, 4 mA output drive, 3.3 V tolerant
V _{CC(I/O)}	48	P	digital supply; 1.65 V to 3.6 V; connect a 100 nF decoupling capacitor
DATA9	49	I/O	data bit 9 input and output bidirectional pad, push-pull input, three-state output, 4 mA output drive, 3.3 V tolerant
V _{REG(1V8)}	50	P	core power output (1.8 V); internal 1.8 V for the digital core; used for decoupling; connect a 100 nF capacitor
DATA10	51	I/O	data bit 10 input and output bidirectional pad, push-pull input, three-state output, 4 mA output drive, 3.3 V tolerant
DATA11	52	I/O	data bit 11 input and output bidirectional pad, push-pull input, three-state output, 4 mA output drive, 3.3 V tolerant
GND	53	-	core ground
DATA12	54	I/O	data bit 12 input and output bidirectional pad, push-pull input, three-state output, 4 mA output drive, 3.3 V tolerant
GND	55	-	digital ground
DATA13	56	I/O	data bit 13 input and output bidirectional pad, push-pull input, three-state output, 4 mA output drive, 3.3 V tolerant
DATA14	57	I/O	data bit 14 input and output bidirectional pad, push-pull input, three-state output, 4 mA output drive, 3.3 V tolerant
DATA15	58	I/O	data bit 15 input and output bidirectional pad, push-pull input, three-state output, 4 mA output drive, 3.3 V tolerant
V _{CC(I/O)}	59	P	digital supply; 1.65 V to 3.6 V; connect a 100 nF decoupling capacitor

Table 2: Pin description...continued

Symbol [1]	Pin	Type [2]	Description
DATA16	60	I/O	data bit 16 input and output bidirectional pad, push-pull input, three-state output, 4 mA output drive, 3.3 V tolerant
DATA17	61	I/O	data bit 17 input and output bidirectional pad, push-pull input, three-state output, 4 mA output drive, 3.3 V tolerant
DATA18	62	I/O	data bit 18 input and output bidirectional pad, push-pull input, three-state output, 4 mA output drive, 3.3 V tolerant
GND	63	-	digital ground
DATA19	64	I/O	data bit 19 input and output bidirectional pad, push-pull input, three-state output, 4 mA output drive, 3.3 V tolerant
DATA20	65	I/O	data bit 20 input and output bidirectional pad, push-pull input, three-state output, 4 mA output drive, 3.3 V tolerant
DATA21	66	I/O	data bit 21 input and output bidirectional pad, push-pull input, three-state output, 4 mA output drive, 3.3 V tolerant
V _{CC(I/O)}	67	P	digital supply; 1.65 V to 3.6 V; connect a 100 nF decoupling capacitor
DATA22	68	I/O	data bit 22 input and output bidirectional pad, push-pull input, three-state output, 4 mA output drive, 3.3 V tolerant
DATA23	69	I/O	data bit 23 input and output bidirectional pad, push-pull input, three-state output, 4 mA output drive, 3.3 V tolerant
DATA24	70	I/O	data bit 24 input and output bidirectional pad, push-pull input, three-state output, 4 mA output drive, 3.3 V tolerant
GND	71	-	digital ground
DATA25	72	I/O	data bit 25 input and output bidirectional pad, push-pull input, three-state output, 4 mA output drive, 3.3 V tolerant
DATA26	73	I/O	data bit 26 input and output bidirectional pad, push-pull input, three-state output, 4 mA output drive, 3.3 V tolerant
DATA27	74	I/O	data bit 27 input and output bidirectional pad, push-pull input, three-state output, 4 mA output drive, 3.3 V tolerant
V _{CC(I/O)}	75	P	digital supply; 1.65 V to 3.6 V; connect a 100 nF decoupling capacitor
DATA28	76	I/O	data bit 28 input and output bidirectional pad, push-pull input, three-state output, 4 mA output drive, 3.3 V tolerant

Table 2: Pin description...continued

Symbol [1]	Pin	Type [2]	Description
DATA29	77	I/O	data bit 29 input and output bidirectional pad, push-pull input, three-state output, 4 mA output drive, 3.3 V tolerant
DATA30	78	I/O	data bit 30 input and output bidirectional pad, push-pull input, three-state output, 4 mA output drive, 3.3 V tolerant
GND	79	-	digital ground
DATA31	80	I/O	data bit 31 input and output bidirectional pad, push-pull input, three-state output, 4 mA output drive, 3.3 V tolerant
TEST	81	-	connect to ground
A1	82	I	address pin 1 input, 3.3 V tolerant
V _{CC(I/O)}	83	P	digital supply; 1.65 V to 3.6 V; connect a 100 nF decoupling capacitor
A2	84	I	address pin 2 input, 3.3 V tolerant
V _{REG(1V8)}	85	P	core power output (1.8 V); internal 1.8 V for the digital core; used for decoupling; connect a 100 nF capacitor and a 4.7 µF to 10 µF capacitor
A3	86	I	address pin 3 input, 3.3 V tolerant
A4	87	I	address pin 4 input, 3.3 V tolerant
GND	88	-	core ground
A5	89	I	address pin 5 input, 3.3 V tolerant
GND	90	-	digital ground
A6	91	I	address pin 6 input, 3.3 V tolerant
A7	92	I	address pin 7 input, 3.3 V tolerant
A8	93	I	address pin 8 input, 3.3 V tolerant
V _{CC(I/O)}	94	P	digital supply; 1.65 V to 3.6 V; connect a 100 nF decoupling capacitor
A9	95	I	address pin 9 input, 3.3 V tolerant
A10	96	I	address pin 10 input, 3.3 V tolerant
A11	97	I	address pin 11 input, 3.3 V tolerant
A12	98	I	address pin 12 input, 3.3 V tolerant

Table 2: Pin description...continued

Symbol [1]	Pin	Type [2]	Description
GND	99	-	digital ground
A13	100	I	address pin 13 input, 3.3 V tolerant
A14	101	I	address pin 14 input, 3.3 V tolerant
A15	102	I	address pin 15 input, 3.3 V tolerant
A16	103	I	address pin 16 input, 3.3 V tolerant
V _{CC(I/O)}	104	P	digital voltage; 1.65 V to 3.6 V; connect a 100 nF decoupling capacitor
A17	105	I	address pin 17 input, 3.3 V tolerant
CS_N	106	I	chip select signal that indicates the area being accessed; active LOW input, 3.3 V tolerant
RD_N	107	I	read enable; active LOW input, 3.3 V tolerant
WR_N	108	I	write enable; active LOW input, 3.3 V tolerant
GND	109	-	digital ground
V _{BAT_ON_N}	110	OD	to indicate the presence of a minimum 3.3 V on pins 6 and 7 (open-drain); connect to V _{CC(I/O)} through a 10 kΩ pull-up resistor output pad, push-pull open-drain, 8 mA output drive, 5 V tolerant
n.c.	111	-	not connected
IRQ	112	O	Host Controller interrupt signal output pad, 4 mA drive, 3.3 V tolerant
n.c.	113	-	not connected
DREQ	114	O	DMAC request for the Host Controller output pad, 4 mA drive, 3.3 V tolerant
V _{CC(I/O)}	115	P	digital voltage; 1.65 V to 3.6 V; connect a 100 nF decoupling capacitor
DACK	116	I	Host Controller DMA request acknowledgment; when not in use, connect to V _{CC(I/O)} through a 10 kΩ pull-up resistor input, 3.3 V tolerant
TEST	117	-	connect to ground
V _{REG(1V8)}	118	P	core power output (1.8 V); internal 1.8 V for the digital core; used for decoupling; connect a 100 nF capacitor
SUSPEND/ WAKEUP_ N	119	I/OD	Host Controller suspend and wake-up; three-state suspend output (active LOW) and wake-up input circuits are connected together <ul style="list-style-type: none"> • HIGH = output is three-state; ISP1760 is in suspend mode; connect to V_{CC(I/O)} through an external 10 kΩ pull-up resistor • LOW = output is LOW; ISP1760 is not in suspend mode. output pad, open-drain, 4 mA output drive, 3.3 V tolerant

Table 2: Pin description...continued

Symbol [1]	Pin	Type [2]	Description
TEST	120	-	pull up to $V_{CC(I/O)}$
GND	121	-	core ground
RESET_N	122	I	external power-up reset; active LOW input, 3.3 V tolerant
GND	123	-	analog ground
TEST	124	-	connect a 220 nF capacitor between this pin and pin 125
TEST	125	-	connect a 220 nF capacitor between this pin and pin 124
TEST	126	-	connect to 3.3 V
OC1_N	127	AI	port 1 analog (5 V input) and digital overcurrent input; if not used, connect to $V_{CC(I/O)}$ through a 10 k Ω resistor
OC2_N	128	AI	port 2 analog (5 V input) and digital overcurrent input; if not used, connect to $V_{CC(I/O)}$ through a 10 k Ω resistor

[1] Symbol names ending with underscore N (for example, NAME_N) represent active LOW signals.

[2] I = input only; O = output only; I/O = digital input/output; OD = open-drain output; AI/O = analog input/output; AI = analog input; P = power.

7. Functional description

7.1 ISP1760 internal architecture: Advanced Philips Slave Host Controller and hub

The EHCI block and the Hi-Speed USB hub block are the main components of the Advanced Philips Slave Host Controller.

The EHCI is the latest generation design, with improved data bandwidth. The EHCI in the ISP1760 is adapted from *Enhanced Host Controller Interface Specification for Universal Serial Bus Rev. 1.0*.

The internal Hi-Speed USB hub block replaces the companion Host Controller block used in the original PCI Hi-Speed USB Host Controllers to handle the full-speed and low-speed modes. The hardware architecture in the ISP1760 is simplified to help reduce cost and development time, by eliminating the additional work involved in implementing the OHCI software required to support the full-speed and low-speed modes.

[Figure 3](#) shows the internal architecture of the ISP1760. The ISP1760 implements the EHCI that has an internal port—the Root Hub port (not available externally)—on which the internal hub is connected. The three external ports are always routed to the internal hub. The internal hub is a Hi-Speed USB (USB 2.0) hub including the TT.

Remark: The root hub must be enabled and the internal hub must be enumerated. Enumerate the internal hub as if it is externally connected. For details, refer to *ISP176x Linux Programming Guide (AN10042)*.

At the Host Controller reset and initialization, the internal Root Hub port will be polled until a new connection is detected, showing the connection of the internal hub.

The internal Hi-Speed USB hub is enumerated using a sequence similar to a standard Hi-Speed USB hub enumeration sequence, and the polling on the Root Hub is stopped because the internal Hi-Speed USB hub will never be disconnected. When enumerated, the internal hub will report the three externally available ports.

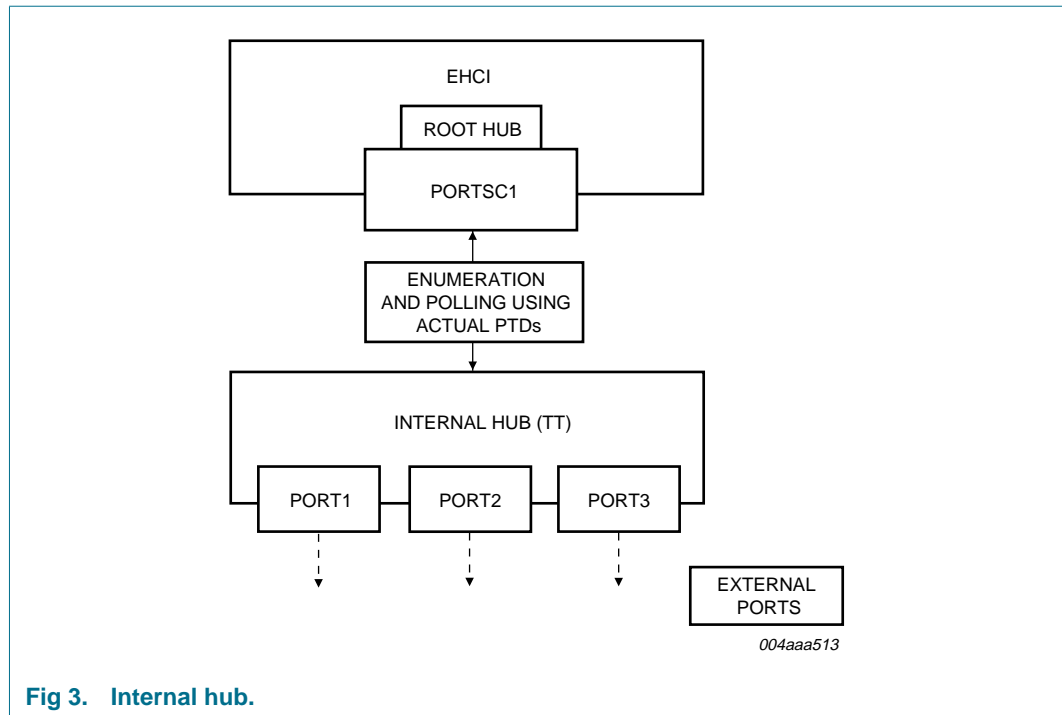

Fig 3. Internal hub.

7.2 Host Controller buffer memory block

7.2.1 General considerations

The internal addressable Host Controller buffer memory is 63 kbytes. The 63-kbyte effective memory size is the result of subtracting the size of registers (1 kbyte) from the total addressable memory space defined in the ISP1760 (64 kbytes). This is the optimized value for achieving the highest performance with a minimal cost.

The ISP1760 is a slave Host Controller. This means that it does not need access to the local bus of the system to transfer data from the memory of the system to the ISP1760 internal memory, unlike the case of the original PCI Hi-Speed USB Host Controllers. Therefore, correct data must be transferred to both the Philips Transfer Descriptor (PTD) area and the payload area by Parallel I/O (PIO) (CPU access) or programmed DMA.

The 'slave-host' architecture ensures better compatibility with most of the processors present in the market today because not all processors allow a 'bus-master' on the local bus. It also allows better load balancing of the processor's local bus because only the internal bus arbiter of the processor controls the transfer of data dedicated to USB. This prevents the local bus from being busy when other more important transfers may be in the queue; and therefore achieving a 'linear' system data flow that has less impact on other processes running at the same time.

The considerations mentioned are also the main reason for implementing the prefetching technique, instead of using a READY signal. The resulting architecture avoids 'freezing' of the local bus (by asserting READY), enhancing the ISP1760 memory access time, and avoiding introduction of programmed additional wait states. For details, see [Section 7.3](#) and [Section 8.3.8](#).

The total amount of memory allocated to the payload determines the maximum transfer size specified by a PTD—a larger internal memory size results in less CPU interruption for transfer programming. This means less time spent in context switching, resulting in better CPU usage.

A larger buffer also implies a larger amount of data can be transferred. The transfer, however, can be done over a longer period of time, to maintain the overall system performance. Each transfer of the USB data on the USB bus can span for up to a few milliseconds before requiring further CPU intervention for data movement.

The internal architecture of the ISP1760 allows a flexible definition of the memory buffer for optimization of the data transfer on the CPU extension bus and the USB. It is possible to implement various data transfer schemes, depending on the number and type of USB devices present (for example: push-pull—data can be written to half of the memory while data in the other half is being accessed by the Host Controller and sent on the USB bus). This is useful especially when a high-bandwidth 'continuous or periodic' data flow is required.

Through an analysis of the hardware and software environment regarding the usual data flow and performance requirements of most embedded systems, Philips has determined the optimal size for the internal buffer as approximately 64 kbytes.

7.2.2 Structure of the ISP1760 Host Controller memory

The 63-kbyte internal memory consists of the PTD area and the payload area.

Both the PTD and payload memory zones are divided into three dedicated areas for each main type of USB transfer: isochronous (ISO), interrupt (INT) and Acknowledged Transfer List (ATL). As shown in [Table 3](#), the PTD areas for ISO, INT and ATL are grouped at the beginning of the memory, occupying the address range 0400h to 0FFFh, following the address space of the registers. The payload or data area occupies the next memory address range 1000h to FFFFh, meaning that 60 kbytes of memory are allocated for the payload data.

A maximum of 32 PTD areas and their allocated payload areas can be defined for each type of transfer. The structure of a PTD is similar for every transfer type and consists of eight Double Words (DWs) that must be correctly programmed for a correct USB data transfer. The reserved bits of a PTD must be set to logic 0. A detailed description of the PTD structure can be found in [Section 9](#).

The transfer size specified by the PTD determines the contiguous USB data transfer that can be performed without any CPU intervention. The respective payload memory area must be equal to the transfer size defined. The maximum transfer size is flexible and can be optimized, depending on the number and nature of USB devices or PTDs defined and their respective MaxPacketSize.

The CPU will program the DMA to transfer the necessary data in the payload memory. The next CPU intervention will be required only when the current transfer is completed and DMA programming is necessary to transfer the next data payload. This is normally signaled by the IRQ that is generated by the ISP1760 on completing the current PTD, meaning all the data in the payload area was sent on the USB bus. The external IRQ signal is asserted according to the settings in the IRQ Mask OR or IRQ Mask AND registers, see [Section 8.4](#).

The RAM is structured in blocks of PTDs and payloads so that while the USB is executing on an active transfer-based PTD, the processor can simultaneously fill up another block area in the RAM. A PTD and its payload can then be updated on-the-fly without stopping or delaying any other USB transaction or corrupting the RAM data.

Some of the design features are:

- The address range of the internal RAM buffer is from 0400h to FFFFh.
- The internal memory contains isochronous, interrupt and asynchronous PTDs, and respective defined payloads.
- All accesses to the internal memory are double-word aligned.
- Internal memory address range calculation:
Memory address = (CPU address – 0400h) (shift right >> 3). Base address is 0400h.

Table 3: Memory address

Memory map	CPU address	Memory address
ISO	0400h to 07FFh	0000h to 007Fh
INT	0800h to 0BFFh	0080h to 00FFh
ATL	0C00h to 0FFFh	0100h to 017Fh
Payload	1000h to FFFFh	0180h to 1FFFh

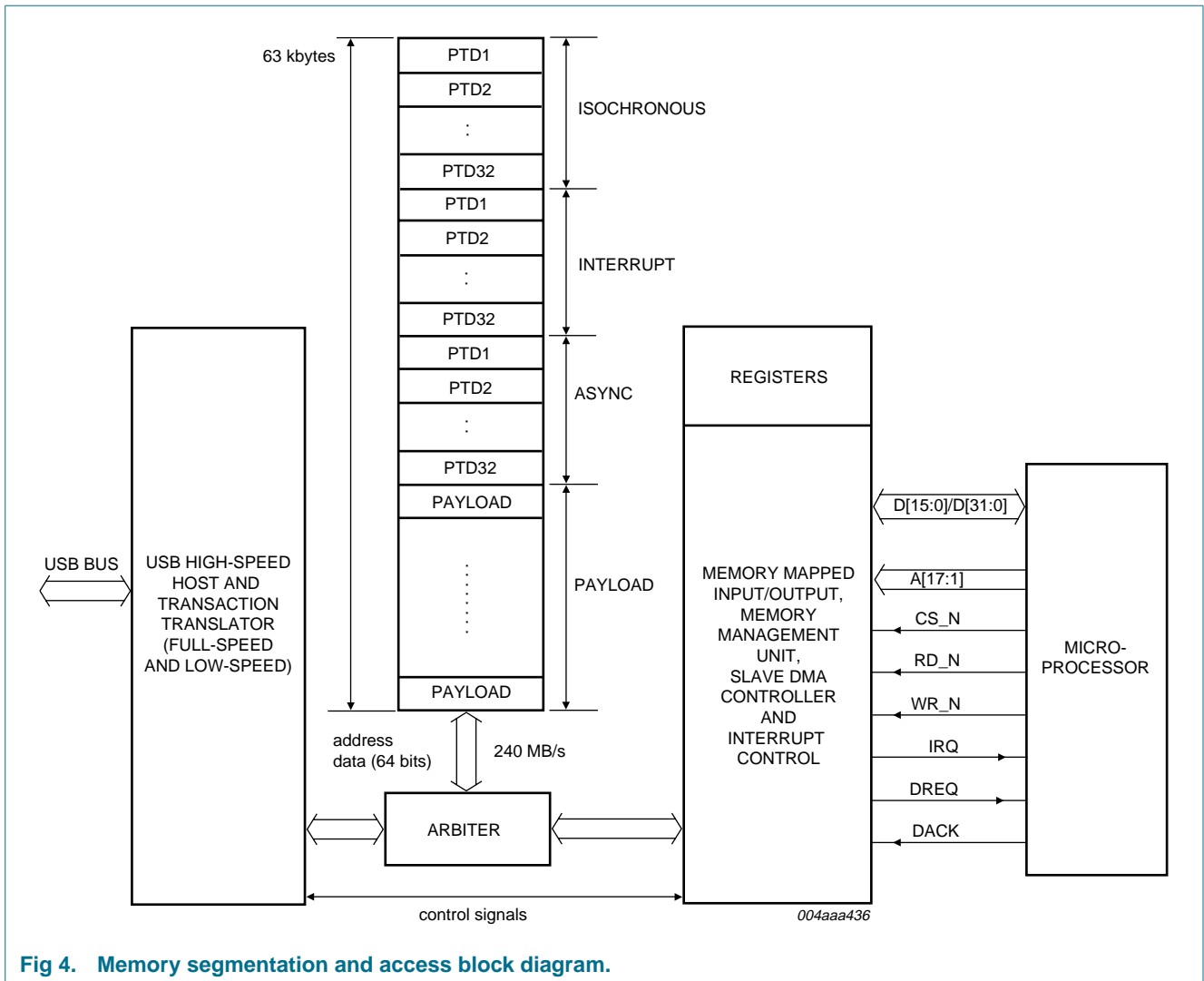

Fig 4. Memory segmentation and access block diagram.

Both the CPU interface logic and the USB Host Controller require access to the internal ISP1760 RAM at the same time. The internal arbiter controls these accesses to the internal memory, organized internally on a 64-bit data bus width, allowing a maximum bandwidth of 240 MB/s. This bandwidth avoids any bottleneck on accesses both from the CPU interface and the internal USB Host Controller.

7.3 Accessing the ISP1760 Host Controller memory: PIO and DMA

The CPU interface of the ISP1760 can be configured for a 16-bit or 32-bit data bus width. When the ISP1760 is configured for a 16-bit data bus width, the upper unused 16 data lines must be pulled up to $V_{CC(I/O)}$. This can be achieved by connecting DATA[31:16] lines together to a single 10 kΩ pull-up resistor. The 16-bit or 32-bit data bus width configuration is done by programming bit 8 of the HW Mode Control register. This will determine the register and memory access types in both PIO and DMA modes to all internal blocks: Host Controller, Peripheral Controller and OTG Controller. All accesses must be word-aligned for 16-bit mode and double-word aligned for 32-bit mode, where one word = 16 bits. When accessing the Host Controller registers in 16-bit mode, the

register access must always be completed using two subsequent accesses. In the case of a DMA transfer, the 16-bit or 32-bit data bus width configuration will determine the number of bursts that will complete a certain transfer length.

In PIO mode, CS_N, WR_N and RD_N are used to access registers and memory. In DMA mode, the data validation is performed by DACK—instead of CS_N—together with the WR_N and RD_N signals. The DREQ signal will always be asserted as soon as the ISP1760 DMA is enabled, as described in the following section.

7.3.1 PIO mode access—memory read cycle

The following method has been implemented to reduce the read access timing in the case of a memory read:

- The Memory register contains the starting address and the bank selection to read from the memory. Before every new read cycle of the same or different banks, an appropriate value is written to this register.
- Once a value is written to this register, the address is stored in the FIFO of that bank and is then used to prefetch data for the memory read of that bank.

For every subsequent read operation executed at a contiguous address, the address pointer corresponding to that bank is automatically incremented to prefetch the next data to be sent to the CPU.

Memory read accesses for multiple banks can be interleaved. In this case, the FIFO block handles the MUXing of appropriate data to the CPU.

- The address written to the Memory register is incremented and used to successively prefetch data from the memory irrespective of the value on the address bus for each bank, until a new value for a bank is written to the Memory register.

For example, consider the following sequence of operations:

- Write the starting (read) address 4000h and bank1 = 01 to the Memory register. When RD_N is asserted for three cycles with A[17:16] = 01, the returned data corresponds to addresses 4000h, 4004h and 4008h.

Remark: Once 4000h is written to the Memory register for bank1, the bank select value determines the successive incremental addresses used to fetch the data. That is, the fetching of data is independent of the address on A[15:0] lines.

- Write the starting (read) address 4100h and bank2 = 10 to the Memory register. When RD_N is asserted for four cycles with A[17:16] = 10, the returned data corresponds to addresses 4100h, 4104h, 4108h and 410Ch.

Consequently, the RD_N assertion with A[17:16] = 01 will return data from 400Ch because the bank1 read stopped there in the previous cycle. Also, RD_N assertions with A[17:16] = 010 will now return data from 4110h because the bank2 read stopped there in the previous cycle.

7.3.2 PIO mode access—memory write cycle

The PIO memory write access is similar to a normal memory access. It is not necessary to set the prefetching address before a write cycle to the memory.

The ISP1760 internal write address will not be automatically incremented during consecutive write accesses, unlike in a series of ISP1760 memory read cycles. The memory write address must be incremented before every access.

7.3.3 PIO mode access—register read cycle

The PIO register read access is similar to a general register access. It is not necessary to set a prefetching address before a register read.

The ISP1760 register read address will not be automatically incremented during consecutive read accesses, unlike in a series of ISP1760 memory read cycles. The ISP1760 register read address must be correctly specified before every access.

7.3.4 PIO mode access—register write cycle

The PIO register write access is similar to a general register access. It is not necessary to set a prefetching address before a register write.

The ISP1760 register write address will not be automatically incremented during consecutive write accesses, unlike in a series of ISP1760 memory read cycles. The ISP1760 register write address must be correctly specified before every access.

7.3.5 DMA—read and write operations

The internal ISP1760 Host Controller DMA is a slave DMA. The host system processor or DMA must ensure the data transfer to or from the ISP1760 memory.

The ISP1760 DMA supports a DMA burst length of 1, 4, 8 and 16 cycles for both the 16-bit and 32-bit data bus width. DREQ will be asserted at the beginning of the first burst of a DMA transfer and will be deasserted on the last cycle (RD_N or WR_N active pulse) of that burst. It will be reasserted shortly after the DACK deassertion, as long as the DMA transfer counter was not reached. DREQ will be deasserted on the last cycle when the DMA transfer counter is reached and will not reasserted until the DMA reprogramming is performed. Both the DREQ and DACK signals are programmable as active LOW or active HIGH, according to the system requirements.

The DMA start address must be initialized in the respective register, and the subsequent transfers will automatically increment the internal ISP1760 memory address. A register or memory access or access to other system memory can occur in between DMA bursts, whenever the bus is released because DACK is deasserted, without affecting the DMA transfer counter or the current address.

Any memory area can be accessed by the system's DMA at any starting address because there are no predefined memory blocks. The DMA transfer must start on a word or Double Word address, depending on whether the data bus width is set to 16 bit or 32 bit. DMA is the most efficient method to initialize the payload area, to reduce the CPU usage and overall system loading.

The ISP1760 does not implement EOT to signal the end of a DMA transfer. If programmed, an interrupt may be generated by the ISP1760 at the end of the DMA transfer.

The slave DMA of the ISP1760 will issue a DREQ to the DMA controller of the system to indicate that it is programmed for transfer and data is ready. The system DMA controller may also start a transfer without the need of the DREQ, if the ISP1760 memory is available for the data transfer and the ISP1760 DMA programming is completed.

It is also possible that the system's DMA will perform a memory-to-memory type of transfer between the system memory and the ISP1760 memory. The ISP1760 will be accessed in the PIO mode. Consequently, memory read operations must be preceded by initializing the Memory register (address 033Ch), as described in [Section 7.3.1](#). No IRQ will be generated by the ISP1760 on completing the DMA transfer but an internal processor interrupt may be generated to signal that the DMA transfer is completed. This is mainly useful in implementing the double-buffering scheme for data transfer to optimize the USB bandwidth.

The ISP1760 DMA programming involves:

- Set the active levels of signals DREQ and DACK in the HW Mode Control register.
- The DMA Start Address register contains the first memory address at which the data transfer will start. It must be word-aligned in the 16-bit data bus mode and double word aligned in the 32-bit data bus mode.
- The programming of the DMA Configuration register specifies:
 - The type of transfer that will be performed: read or write
 - The burst size—expressed in bytes—is specified, regardless of the data bus width. For the same burst size, a double number of cycles will be generated in the 16-bit mode data bus width as compared to the 32-bit mode.
 - The transfer length—expressed in number of bytes—defines the number of bursts. The DREQ will be deasserted and asserted to generate the next burst, as long as there are bytes to be transferred. At the end of a transfer, the DREQ will be deasserted and an IRQ can be generated if DMAEOTINT (bit 3 in the Interrupt register) is set. The maximum DMA transfer size is equal to the maximum memory size. The transfer size can be an odd or even number of bytes, as required. If the transfer size is an odd number of bytes, the number of bytes transferred by the system's DMA is equal to the next multiple of two for the 16-bit data bus width or four for the 32-bit data bus width. For a write operation, however, only the specified odd number of bytes in the ISP1760 memory will be affected.
 - Enable ENABLE_DMA (bit 1) of the DMA Configuration register to determine the assertion of DREQ immediately after setting the bit.

After programming the preceding parameters, the system's DMA may be enabled (waiting for the DREQ to start the transfer or immediate transfer may be started).

The programming of the system's DMA must match the ISP1760 DMA parameters programmed above. Only one DMA transfer may take place at a time. A PIO mode data transfer may occur simultaneously with a DMA data transfer, in the same or a different memory area.

7.4 Interrupts

The ISP1760 will assert an IRQ according to the source or event in the Interrupt register. The main steps to enable the IRQ assertion are:

1. Set GLOBAL_INTR_EN (bit 0) in the HW Mode Control register.
2. Define the IRQ active as level or edge in INTR_LEVEL (bit 1) of the HW Mode Control register.

3. Define the IRQ polarity as active LOW or active HIGH in INTR_POL (bit 2) of the HW Mode Control register. These settings must match the IRQ settings of the host processor.

By default, interrupt is level-triggered and active LOW.

4. Program the individual interrupt enable bits in the Interrupt Enable register. The software will need to clear the interrupt status bits in the Interrupt register before enabling individual interrupt enable bits.

Additional IRQ characteristics can be adjusted in the Edge Interrupt Count register, as necessary, applicable only when IRQ is set to be edge-active (a pulse of a defined width is generated every time IRQ is active).

Bits 15 to 0 of the Edge Interrupt Count register define the IRQ pulse width. The maximum pulse width that can be programmed is FFFFh, corresponding to a 1 ms pulse width. This setting is necessary for certain processors that may require a different minimum IRQ pulse width than the default value. The default IRQ pulse width set at power on is approximately 500 ns.

Bits 31 to 24 of the Edge Interrupt Count register define the minimum interval between two interrupts to avoid frequent interrupts to the CPU. The default value of 00h attributed to these bits determines the normal IRQ generation, without any delay. When a delay is programmed and the IRQ becomes active after the respective delay, several IRQ events may have already occurred.

All the interrupt events are represented by the respective bits allocated in the Interrupt register. There is no mechanism to show the order or the moment of occurrence of an interrupt.

The asserted bits in the Interrupt register can be cleared by writing back the same value to the Interrupt register. This means that writing logic 1 to each of the set bits will reset the corresponding bits to the initial inactive state.

The IRQ generation rules that apply according to the preceding settings are:

- If an event of interrupt occurs but the respective bit in the Interrupt Enable register is not set, then the respective Interrupt register bit is set but the interrupt signal is not asserted.
An interrupt will be generated when interrupt is enabled and the respective bit in the Interrupt Enable register is set.
- For a level trigger, an interrupt signal remains asserted until the processor clears the Interrupt register by writing logic 1 to clear the Interrupt register bits that are set.
- If an interrupt is made edge-sensitive and is asserted, writing to clear the Interrupt register will not have any effect because the interrupt will be asserted for a prescribed amount of clock cycles.
- The clock stopping mechanism does not affect the generation of an interrupt. This is useful during the suspend and resume cycles, when an interrupt is generated to signal a wake-up event.

The IRQ generation can also be conditioned by programming the IRQ Mask OR and IRQ Mask AND registers. Setting some of the bits in these registers to logic 1 will determine the IRQ generation only when the respective AND or OR conditions of completing the respective PTDs is met.

With the help of the IRQ Mask AND and IRQ Mask OR registers for each type of transfer—ISO, INT and bulk—software can determine which PTDs get priority and an interrupt will be generated when the AND or OR conditions are met. The PTDs that are set will wait until the respective bits of the remaining PTDs are set and then all PTDs generate an interrupt request to the CPU together.

The registers definition shows that the AND or OR conditions are applicable to the same category of PTDs—ISO, INT, ATL.

When an IRQ is generated, the PTD Done Map registers and the respective V bits will show which PTDs were completed.

The rules that apply to the IRQ Mask AND or IRQ Mask OR settings are:

- The OR mask has a higher priority over the AND mask. An IRQ is generated if bit n of the done map is set and the corresponding bit n of the OR Mask register is set.
- If the OR mask for any done bit is not set, then the AND mask comes into picture. An IRQ is generated if all the corresponding done bits of the AND Mask register are set. For example: If bits 2, 4 and 10 are set in the AND Mask register, an IRQ is generated only if bits 2, 4, 10 of the done map are set.
- If using the IRQ interval setting for the bulk PTD, an interrupt will only occur at the regular time interval as programmed in the ATL Done Timeout register. Even if an interrupt event occurs before the timeout of the register, no IRQ will be generated until the time is up.

For an example on using the IRQ Mask AND or IRQ Mask OR registers without the ATL Done Timeout register, see [Table 4](#).

The AND function: Activate the IRQ only if PTDs 1, 2 and 4 are done.

The OR function: If any of the PTDs 7, 8 or 9 are done, an IRQ for each of the PTD will be raised.

Table 4: Using the IRQ Mask AND or IRQ Mask OR registers

PTD	AND register	OR register	Time	PTD done	IRQ
1	1	0	1 ms	1	-
2	1	0	-	1	-
3	0	0	-	-	-
4	1	0	3 ms	1	active because of AND
5	0	0	-	-	-
6	0	0	-	-	-
7	0	1	5 ms	1	active because of OR
8	0	1	6 ms	1	active because of OR
9	0	1	7 ms	1	active because of OR

7.5 Phase-Locked Loop (PLL) clock multiplier

The internal PLL requires a 12 MHz input, which can be a 12 MHz crystal or a 12 MHz clock already existing in the system with a precision better than 50 ppm. This allows the use of a low-cost 12 MHz crystal that also minimizes Electro-Magnetic Interference (EMI). When an external crystal is used, make sure the CLKIN pin is connected to $V_{CC(I/O)}$.

The PLL block generates all the main internal clocks required for normal functionality of various blocks: 30 MHz, 48 MHz and 60 MHz.

No external components are required for the PLL operation.

7.6 Power management

The ISP1760 implements a flexible power management scheme, allowing various power saving stages.

The usual powering scheme implies programming EHCI registers and the internal Hi-Speed USB (USB 2.0) hub in the same way it is done in the case of a PCI Hi-Speed USB Host Controller with a Hi-Speed USB hub attached.

When the ISP1760 is in suspend mode, the main internal clocks will be stopped to ensure minimum power consumption. An internal LazyClock of 100 kHz \pm 40 % will continue running. This allows initiating a resume on one of the following events:

- External USB device connect or disconnect
- Assertion of the CS_N signal because of any access to the ISP1760
- Driving the SUSPEND/WAKEUP_N pin to a LOW level.

The SUSPEND/WAKEUP_N pin is a bidirectional pin. This pin should be connected to one of the GPIO pins of a processor.

The awake state can be verified by reading the LOW level of this pin. If the level is HIGH, it means that the ISP1760 is in the suspend state.

The SUSPEND/WAKEUP_N pin requires a pull-up because in the ISP1760 suspended state the pin becomes three-state and can be pulled down, driving it externally by switching the processor's GPIO line to the output mode to generate the ISP1760 wake-up.

The SUSPEND/WAKEUP_N pin is a three-state output. It is also an input to the internal wake-up logic.

When in suspend mode, the ISP1760 internal wake-up circuitry will sense the status of the SUSPEND/WAKEUP_N pin:

- If it remains pulled-up, no wake-up is generated because a HIGH is sensed by the internal wake-up circuit.
- If the pin is externally pulled LOW (for example, by the GPIO line or just as a test by jumper), the input to the wake-up circuitry becomes LOW and the wake-up is internally initiated.

The resume state has a clock-off count timer defined by bits 31 to 16 of the Power Down Control register. The default value of this timer is 10 ms, meaning that the resume state will be maintained for 10 ms. If during this time, the RUN/STOP bit in the USBCMD register is set to logic 1, the Host Controller will go into a permanent resume—the normal functional state. If the RUN/STOP bit is not set during the time determined by the clock-off count, the ISP1760 will switch back to suspend mode after the specified time. The maximum delay that can be programmed in the clock-off count field is approximately 500 ms.

Additionally, the Power Down Control register allows the ISP1760 internal blocks to be disabled for lower power consumption as defined in [Table 5](#).

The lowest suspend current that can be achieved is approximately 100 μA at room temperature. The suspend current will increase with the increase in temperature, with approximately 300 μA at 40 °C and up to a typical 1 mA at 85 °C. The system is not in suspend mode when its temperature increases above 40 °C. Therefore, even a 1 mA current consumption by the ISP1760 (in suspend mode) can be considered negligible. In normal environmental conditions, when the system is in suspend mode, the maximum ISP1760 temperature will be approximately 40 °C (determined by the ambient temperature) so the ISP1760 maximum suspend current will be below 300 μA . An alternative solution to achieve a very low suspend current is to completely switch off the $V_{CC(5V0)}$ power input by using an external PMOS transistor, controlled by one of the GPIO pins of the processor. This is possible because the ISP1760 can be used in the hybrid mode, which allows only the $V_{CC(I/O)}$ powered on to avoid loading of the system bus.

The time from wake-up to suspend will be approximately 100 ms when the ISP1760 power is always on.

It is necessary to wait for the CLK_RDY interrupt assertion before programming the ISP1760 because internal clocks are stopped during deep-sleep suspend and restarted after the first wake-up event. The occurrence of the CLK_RDY interrupt means that the internal clocks are running and the normal functionality is achieved.

It is estimated that the CLK_RDY interrupt will be generated less than 100 μs after the wake-up event, if the power to the ISP1760 was on during suspend.

If the ISP1760 is used in the hybrid mode and $V_{CC(5V0)}$ is off during suspend, a 2 ms reset pulse is required when the power is switched back to on, before starting to program the resume state. This will ensure that the internal clocks are running and all logics reach a stable initial state.

7.7 Overcurrent detection

The ISP1760 can implement a digital or analog overcurrent detection scheme. Bit 15 of the HW Mode Control register can be programmed to select the analog or digital overcurrent detection. An analog overcurrent detection circuit is integrated on-chip. The main features of this circuit are self reporting, automatic resetting, low-trip time and low cost. This circuit offers an easy solution at no extra hardware cost on the board. The port power will be automatically disabled by the ISP1760 on an overcurrent event occurrence, by deasserting the PSWn_N signal without any software intervention.

When using the integrated analog overcurrent detection, the range of the overcurrent detection voltage for the ISP1760 is 45 mV to 100 mV. Calculation of the external components should be based on the 45 mV value, with the actual overcurrent detection threshold usually positioned in the middle of the interval.

For an overcurrent limit of 500 mA per port, a PMOS with $R_{\text{DS(on)}}$ of approximately 100 m Ω is required. If a PMOS with a lower $R_{\text{DS(on)}}$ is used, analog overcurrent detection can be adjusted using a series resistor; see [Figure 5](#).

$\Delta V_{\text{PMOS}} = \Delta V_{\text{TRIP}} = \Delta V_{\text{TRIP(intrinsic)}} - (I_{\text{OC(nom)}} \times R_{\text{td}})$, where:

ΔV_{PMOS} = voltage drop on PMOS

$$I_{OC(nom)} = 1 \mu A.$$

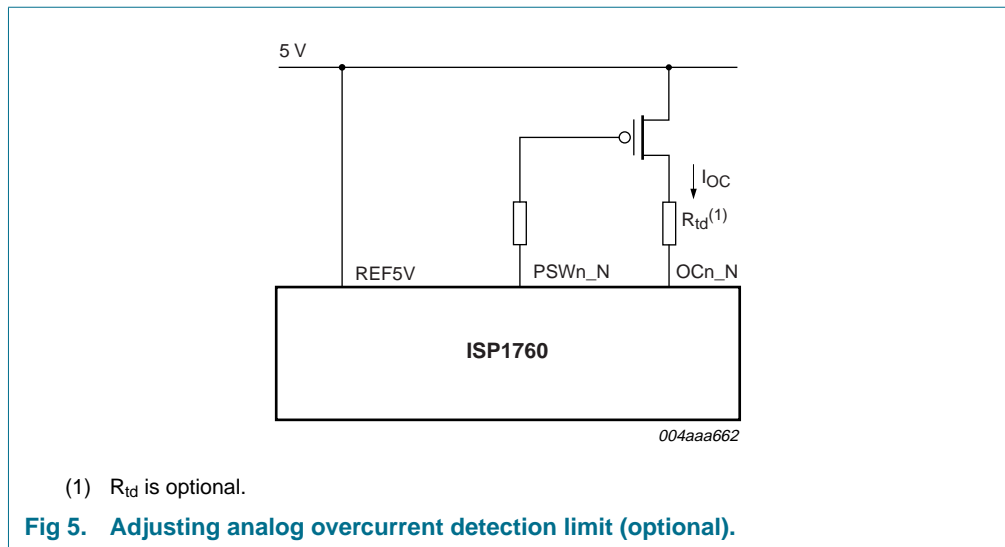

The digital overcurrent scheme requires using an external power switch with integrated overcurrent detection, such as: LM3526, MIC2526 (2 ports) or LM3544 (4 ports). These devices are controlled by PSWn_N signals corresponding to each port. In the case of overcurrent occurrence, these devices will assert OCn_N signals. On OCn_N assertion, the ISP1760 cuts off the port power by deasserting PSWn_N. The external integrated power switch will also automatically cut-off the port power in the case of an overcurrent event, by implementing thermal shutdown. An internal delay filter of 1 ms to 3 ms will prevent false overcurrent reporting because of in-rush currents when plugging a USB device.

7.8 Power supply

Figure 6 shows the ISP1760 power supply connection.

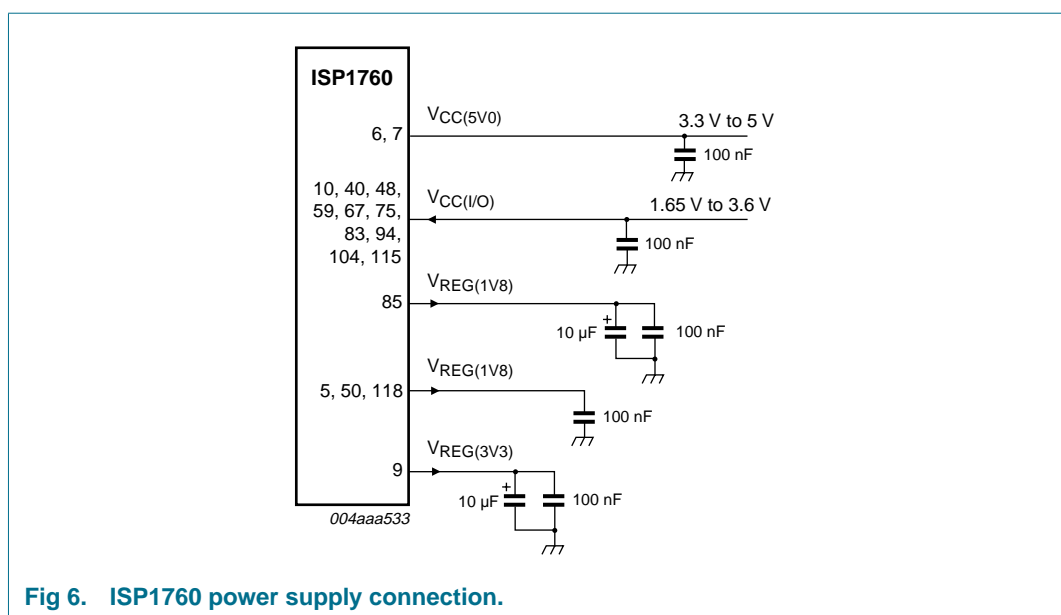

Figure 7 shows the most commonly used power supply connection.

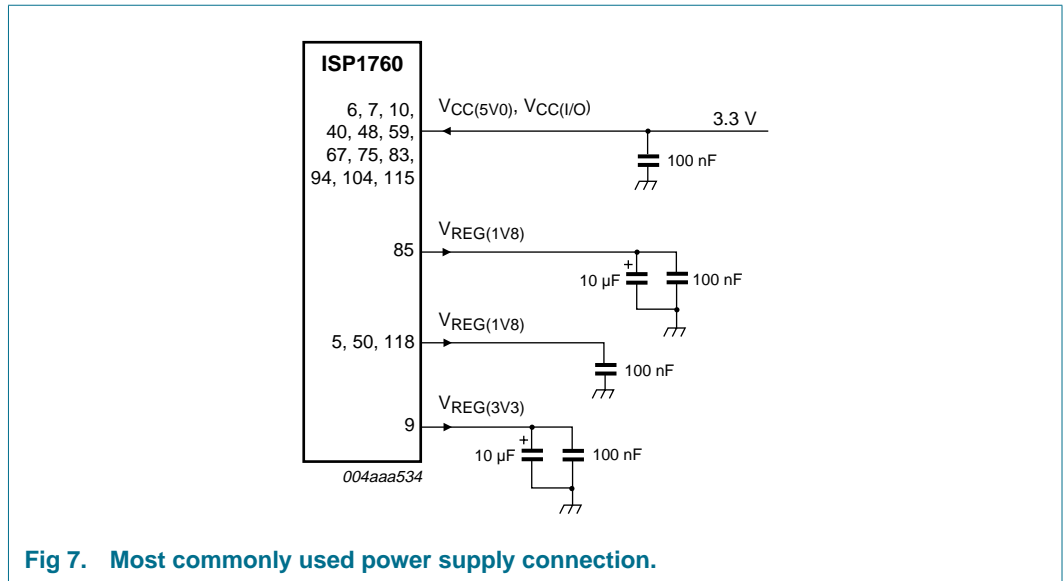

Fig 7. Most commonly used power supply connection.

7.9 Power-on reset (POR)

When $V_{CC(5V0)}$ is directly connected to the RESET_N pin, the internal POR pulse width (t_{PORP}) will be typically 800 ns. The pulse is started when $V_{CC(5V0)}$ rises above V_{TRIP} (1.2 V).

To give a better view of the functionality, Figure 8 shows a possible curve of $V_{CC(5V0)}$ with dips at t_2-t_3 and t_4-t_5 . If the dip at t_4-t_5 is too short (that is, $< 11 \mu s$), the internal POR pulse will not react and will remain LOW. The internal POR starts with a 1 at t_0 . At t_1 , the detector will see the passing of the trip level and a delay element will add another t_{PORP} before it drops to 0.

The internal POR pulse will be generated whenever $V_{CC(5V0)}$ drops below V_{TRIP} for more than $11 \mu s$.

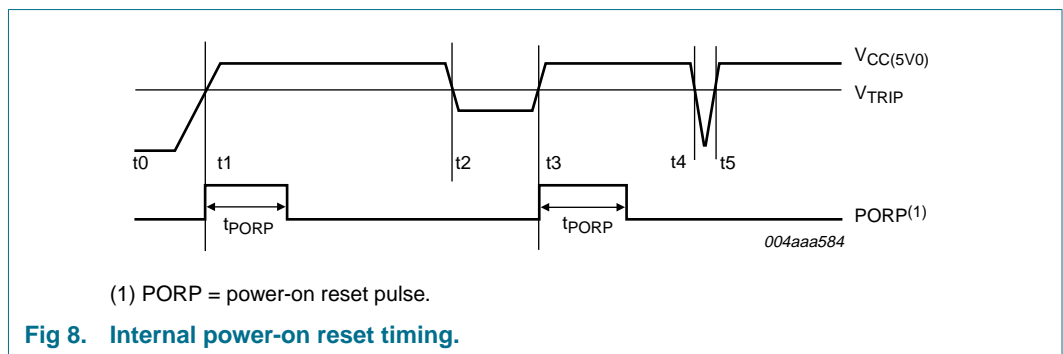

(1) PORP = power-on reset pulse.

Fig 8. Internal power-on reset timing.

The RESET_N pin can be either connected to $V_{CC(I/O)}$ (using the internal POR circuit) or externally controlled (by the microcontroller, ASIC, and so on). Figure 9 shows the availability of the clock with respect to the external POR.

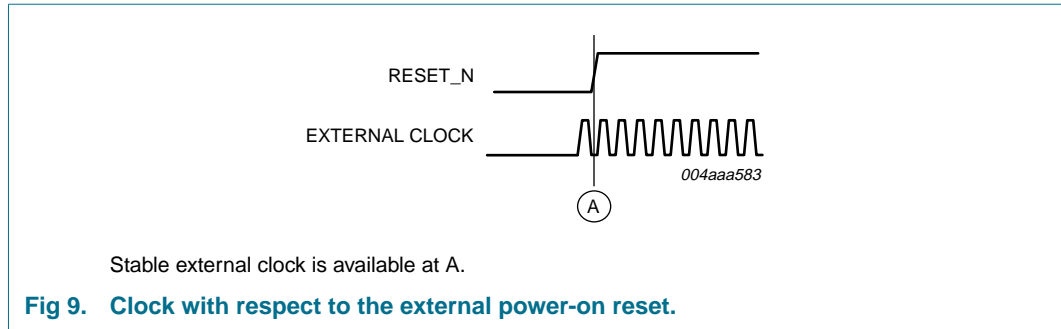

8. Registers

[Table 5](#) shows the bit description of the registers.

- All registers range from 0000h to 03FFh. These registers can be read or written as double word, that is 32-bit data. In the case of a 16-bit data bus width, two subsequent accesses are necessary to complete the register read or write cycle.
- Operational registers range from 0000h to 01FFh. Configuration registers range from 0300h to 03FFh.

Table 5: Register overview

Address	Register	Reset value	References
EHCI capability registers			
0000h	CAPLENGTH	20h	Section 8.1.1 on page 28
0002h	HCIVERSION	0100h	Section 8.1.2 on page 28
0004h	HCSPARAMS	0000 0011h	Section 8.1.3 on page 28
0008h	HCCPARAMS	0000 0086h	Section 8.1.4 on page 29
EHCI operational registers			
0020h	USBCMD	0008 0000h	Section 8.2.1 on page 30
0024h	USBSTS	0000 1000h	Section 8.2.2 on page 31
0028h	USBINTR	0000 0000h	Section 8.2.3 on page 32
002Ch	FRINDEX	0000 0000h	Section 8.2.4 on page 33
0030h	CTRLDSSEGMENT	0000 0000h	Section 8.2.5 on page 34
0060h	CONFIGFLAG	0000 0000h	Section 8.2.6 on page 34
0064h	PORTSC1	0000 2000h	Section 8.2.7 on page 35
0130h	ISO PTD Done Map	0000 0000h	Section 8.2.8 on page 36
0134h	ISO PTD Skip Map	FFFF FFFFh	Section 8.2.9 on page 37
0138h	ISO PTD Last PTD	0000 0000h	Section 8.2.10 on page 37
0140h	INT PTD Done Map	0000 0000h	Section 8.2.11 on page 37
0144h	INT PTD Skip Map	FFFF FFFFh	Section 8.2.12 on page 38
0148h	INT PTD Last PTD	0000 0000h	Section 8.2.13 on page 38
0150h	ATL PTD Done Map	0000 0000h	Section 8.2.14 on page 38
0154h	ATL PTD Skip Map	FFFF FFFFh	Section 8.2.15 on page 38
0158h	ATL PTD Last PTD	0000 0000h	Section 8.2.16 on page 39
0200h–02FFh	reserved	-	-
Configuration registers			
0300h	HW Mode Control	0000 0000h	Section 8.3.1 on page 39
0304h	Chip ID	0001 1761h	Section 8.3.2 on page 41
0308h	Scratch	0000 0000h	Section 8.3.3 on page 41
030Ch	SW Reset	0000 0000h	Section 8.3.4 on page 41
0330h	DMA Configuration	0000 0000h	Section 8.3.5 on page 42
0334h	Buffer Status	0000 0000h	Section 8.3.6 on page 43
0338h	ATL Done Timeout	0000 0000h	Section 8.3.7 on page 44
033Ch	Memory	0000 0000h	Section 8.3.8 on page 44

Table 5: Register overview...continued

Address	Register	Reset value	References
0340h	Edge Interrupt Count	0000 000Fh	Section 8.3.9 on page 45
0344h	DMA Start Address	0000 0000h	Section 8.3.10 on page 46
0354h	Power Down Control	03E8 1BA0h	Section 8.3.11 on page 46
0374h	Port 1 Control	0086 0086h	Section 8.3.12 on page 48
Interrupt registers			
0310h	Interrupt	0000 0000h	Section 8.4.1 on page 50
0314h	Interrupt Enable	0000 0000h	Section 8.4.2 on page 51
0318h	ISO IRQ Mask OR	0000 0000h	Section 8.4.3 on page 53
031Ch	INT IRQ Mask OR	0000 0000h	Section 8.4.4 on page 53
0320h	ATL IRQ Mask OR	0000 0000h	Section 8.4.5 on page 53
0324h	ISO IRQ Mask AND	0000 0000h	Section 8.4.6 on page 54
0328h	INT IRQ Mask AND	0000 0000h	Section 8.4.7 on page 54
032Ch	ATL IRQ Mask AND	0000 0000h	Section 8.4.8 on page 54

8.1 EHCI capability registers

8.1.1 CAPLENGTH register (R: 0000h)

The bit description of the Capability Length (CAPLENGTH) register is given in [Table 6](#).

Table 6: CAPLENGTH register: bit description

Bit	Symbol	Access	Value	Description
7 to 0	CAPLENGTH [7:0]	R	20h	Capability Length: This is used as an offset. It is added to the register base to find the beginning of the operational register space.

8.1.2 HCIVERSION register (R: 0002h)

[Table 7](#) shows the bit description of the Host Controller Interface Version Number (HCIVERSION) register.

Table 7: HCIVERSION register: bit description

Bit	Symbol	Access	Value	Description
15 to 0	HCIVERSION [15:0]	R	0100h	Host Controller Interface Version Number: It contains a BCD encoding of the version number of the interface to which the Host Controller interface conforms.

8.1.3 HCSPARAMS register (R: 0004h)

The Host Controller Structural Parameters (HCSPARAMS) register is a set of fields that are structural parameters. The bit allocation is given in [Table 8](#).

Table 8: HCSPARAMS register: bit allocation

Bit	31	30	29	28	27	26	25	24
Symbol	reserved							
Reset	0	0	0	0	0	0	0	0
Access	R	R	R	R	R	R	R	R

Bit	23	22	21	20	19	18	17	16
Symbol	DPN[3:0]				reserved			P_INDICATOR
Reset	0	0	0	0	0	0	0	0
Access	R	R	R	R	R	R	R	R
Bit	15	14	13	12	11	10	9	8
Symbol	N_CC[3:0]				N_PCC[3:0]			
Reset	0	0	0	0	0	0	0	0
Access	R	R	R	R	R	R	R	R
Bit	7	6	5	4	3	2	1	0
Symbol	PRR	reserved		PPC	N_PORTS[3:0]			
Reset	0	0	0	1	0	0	0	1
Access	R	R	R	R	R	R	R	R

Table 9: HCSPARAMS register: bit description

Bit	Symbol	Description [1]
31 to 24	-	reserved; write logic 0
23 to 20	DPN[3:0]	Debug Port Number: This field identifies which of the Host Controller ports is the debug port.
19 to 17	-	reserved; write logic 0
16	P_INDICATOR	Port Indicators: This bit indicates whether the ports support port indicator control.
15 to 12	N_CC[3:0]	Number of Companion Controller: This field indicates the number of companion controllers associated with this Hi-Speed USB Host Controller.
11 to 8	N_PCC[3:0]	Number of Ports per Companion Controller: This field indicates the number of ports supported per companion Host Controller.
7	PRR	Port Routing Rules: This field indicates the method used for mapping ports to the companion controllers.
6 to 5	-	reserved; write logic 0
4	PPC	Port Power Control: This field indicates whether the Host Controller implementation includes port power control.
3 to 0	N_PORTS[3:0]	N_Ports: This field specifies the number of physical downstream ports implemented on this Host Controller.

[1] For details on register bit description, refer to *Enhanced Host Controller Interface Specification for Universal Serial Bus Rev. 1.0*.

8.1.4 HCCPARAMS register (R: 0008h)

The Host Controller Capability Parameters (HCCPARAMS) register is a four-byte register, and the bit allocation is given in [Table 10](#).

Table 10: HCCPARAMS register: bit allocation

Bit	31	30	29	28	27	26	25	24
Symbol	reserved							
Reset	0	0	0	0	0	0	0	0
Access	R	R	R	R	R	R	R	R

Bit	23	22	21	20	19	18	17	16
Symbol	reserved							
Reset	0	0	0	0	0	0	0	0
Access	R	R	R	R	R	R	R	R
Bit	15	14	13	12	11	10	9	8
Symbol	EECP[7:0]							
Reset	0	0	0	0	0	0	0	0
Access	R	R	R	R	R	R	R	R
Bit	7	6	5	4	3	2	1	0
Symbol	IST[3:0]			reserved		ASPC	PFLF	64AC
Reset	1	0	0	0	0	1	1	0
Access	R	R	R	R	R	R	R	R

Table 11: HCCPARAMS register: bit description

Bit	Symbol	Description [1]
31 to 16	-	reserved; write logic 0
15 to 8	EECP[7:0]	EHCI Extended Capabilities Pointer: Default = implementation dependent. This optional field indicates the existence of a capabilities list.
7 to 4	IST[3:0]	Isochronous Scheduling Threshold: Default = implementation dependent. This field indicates, relative to the current position of the executing Host Controller, where software can reliably update the isochronous schedule.
3	-	reserved; write logic 0
2	ASPC	Asynchronous Schedule Park Capability: Default = implementation dependent. If this bit is set to logic 1, the Host Controller supports the park feature for high-speed queue heads in the Asynchronous Schedule.
1	PFLF	Programmable Frame List Flag: Default = implementation dependent. If this bit is cleared, the system software must use a frame list length of 1024 elements with this Host Controller. If PFLF is set, the system software can specify and use a smaller frame list and configure the host through the FLS field of the USBCMD register.
0	64AC	64-bit Addressing Capability: This field contains the addressing range capability.

[1] For details on register bit description, refer to *Enhanced Host Controller Interface Specification for Universal Serial Bus Rev. 1.0*.

8.2 EHCI operational registers

8.2.1 USBCMD register (R/W: 0020h)

The USB Command (USBCMD) register indicates the command to be executed by the serial Host Controller. Writing to this register causes a command to be executed. [Table 12](#) shows the USBCMD register bit allocation.

Table 12: USBCMD register: bit allocation

Bit	31	30	29	28	27	26	25	24	
Symbol	reserved [1]								
Reset	0	0	0	0	0	0	0	0	
Access	R/W	R/W	R/W	R/W	R/W	R/W	R/W	R/W	
Bit	23	22	21	20	19	18	17	16	
Symbol	ITC[7:0]								
Reset	0	0	0	0	1	0	0	0	
Access	R/W	R/W	R/W	R/W	R/W	R/W	R/W	R/W	
Bit	15	14	13	12	11	10	9	8	
Symbol	reserved [1]								
Reset	0	0	0	0	0	0	0	0	
Access	R/W	R/W	R/W	R/W	R/W	R/W	R/W	R/W	
Bit	7	6	5	4	3	2	1	0	
Symbol	LHCR	reserved [1]					HCRESET	RS	
Reset	0	0	0	0	0	0	0	0	
Access	R/W	R/W	R/W	R/W	R/W	R/W	R/W	R/W	

[1] The reserved bits should always be written with the reset value.

Table 13: USBCMD register: bit description

Bit	Symbol	Description [1]
31 to 24	-	reserved; write logic 0
23 to 16	ITC[7:0]	Interrupt Threshold Control: This field is used by the system software to select the maximum rate at which the Host Controller will issue interrupts.
15 to 8	-	reserved
7	LHCR	Light Host Controller Reset (optional): If implemented, it allows the driver software to reset the EHCI controller without affecting the state of the ports or the relationship to the companion Host Controllers. If not implemented, a read of this field will always return logic 0.
6 to 2	-	reserved
1	HCRESET	Host Controller Reset: This control bit is used by the software to reset the Host Controller.
0	RS	Run/Stop: 1 = Run, 0 = Stop. When set, the Host Controller executes the schedule.

[1] For details on register bit description, refer to *Enhanced Host Controller Interface Specification for Universal Serial Bus Rev. 1.0*.

8.2.2 USBSTS register (R/W: 0024h)

The USB Status (USBSTS) register indicates pending interrupts and various states of the Host Controller. The status resulting from a transaction on the serial bus is not indicated in this register. Software clears the register bits by writing ones to them. The bit allocation is given in [Table 14](#).

Table 14: USBSTS register: bit allocation

Bit	31	30	29	28	27	26	25	24
Symbol	reserved [1]							
Reset	0	0	0	0	0	0	0	0
Access	R/W	R/W	R/W	R/W	R/W	R/W	R/W	R/W
Bit	23	22	21	20	19	18	17	16
Symbol	reserved [1]							
Reset	0	0	0	0	0	0	0	0
Access	R/W	R/W	R/W	R/W	R/W	R/W	R/W	R/W
Bit	15	14	13	12	11	10	9	8
Symbol	reserved [1]							
Reset	0	0	0	1	0	0	0	0
Access	R/W	R/W	R/W	R/W	R/W	R/W	R/W	R/W
Bit	7	6	5	4	3	2	1	0
Symbol	reserved [1]				FLR	PCD	reserved [1]	
Reset	0	0	0	0	0	0	0	0
Access	R/W	R/W	R/W	R/W	R/W	R/W	R/W	R/W

[1] The reserved bits should always be written with the reset value.

Table 15: USBSTS register: bit description

Bit	Symbol	Description [1]
31 to 4	-	reserved; write logic 0
3	FLR	Frame List Rollover: The Host Controller sets this bit to logic 1 when the Frame List Index rolls over from its maximum value to zero.
2	PCD	Port Change Detect: The Host Controller sets this bit to logic 1 when any port, where the PO bit is cleared, has a change to a one or a FPR bit changes to a one as a result of a J-K transition detected on a suspended port.
1 to 0	-	reserved

[1] For details on register bit description, refer to *Enhanced Host Controller Interface Specification for Universal Serial Bus Rev. 1.0*.

8.2.3 USBINTR register (R/W: 0028h)

The USB Interrupt Enable (USBINTR) register enables and disables reporting of the corresponding interrupt to the software. When a bit is set and the corresponding interrupt is active, an interrupt is generated to the host. Interrupt sources that are disabled in this register still appear in USBSTS to allow the software to poll for events. The USBINTR register bit allocation is given in [Table 16](#).

Table 16: USBINTR register: bit allocation

Bit	31	30	29	28	27	26	25	24
Symbol	reserved [1]							
Reset	0	0	0	0	0	0	0	0
Access	R/W	R/W	R/W	R/W	R/W	R/W	R/W	R/W

Bit	23	22	21	20	19	18	17	16
Symbol	reserved [1]							
Reset	0	0	0	0	0	0	0	0
Access	R/W	R/W	R/W	R/W	R/W	R/W	R/W	R/W
Bit	15	14	13	12	11	10	9	8
Symbol	reserved [1]							
Reset	0	0	0	0	0	0	0	0
Access	R/W	R/W	R/W	R/W	R/W	R/W	R/W	R/W
Bit	7	6	5	4	3	2	1	0
Symbol	reserved [1]				FLRE	PCIE	reserved [1]	
Reset	0	0	0	0	0	0	0	0
Access	R/W	R/W	R/W	R/W	R/W	R/W	R/W	R/W

[1] The reserved bits should always be written with the reset value.

Table 17: USBINTR register: bit description

Bit	Symbol	Description [1]
31 to 4	-	reserved
3	FLRE	Frame List Rollover Enable: When this bit is set and the FLR bit in the USBSTS register is set, the Host Controller issues an interrupt. The interrupt is acknowledged by software clearing bit FLR.
2	PCIE	Port Change Interrupt Enable: When this bit is set and the PCD bit in the USBSTS register is set, the Host Controller issues an interrupt. The interrupt is acknowledged by software clearing bit PCD.
1 to 0	-	reserved

[1] For details on register bit description, refer to *Enhanced Host Controller Interface Specification for Universal Serial Bus Rev. 1.0*.

8.2.4 FRINDEX register (R/W: 002Ch)

The Frame Index (FRINDEX) register is used by the Host Controller to index into the periodic frame list. The register updates every 125 μs (once each microframe). Bits n to 3 are used to select a particular entry in the Periodic Frame List during periodic schedule execution. The number of bits used for the index depends on the size of the frame list as set by the system software in the FLS (Frame List Size) field of the USBCMD register. This register must be written as a Double Word. A Word-only write (16-bit mode) produces undefined results. This register cannot be written unless the Host Controller is in the halted state as indicated by the HCH (HCHalted) bit. A write to this register while the RS (Run/Stop) bit is set produces undefined results. Writes to this register also affect the SOF value. The bit allocation is given in [Table 18](#).

Table 18: FRINDEX register: bit allocation

Bit	31	30	29	28	27	26	25	24
Symbol	reserved [1]							
Reset	0	0	0	0	0	0	0	0
Access	R/W	R/W	R/W	R/W	R/W	R/W	R/W	R/W

Bit	23	22	21	20	19	18	17	16
Symbol	reserved ^[1]							
Reset	0	0	0	0	0	0	0	0
Access	R/W	R/W	R/W	R/W	R/W	R/W	R/W	R/W
Bit	15	14	13	12	11	10	9	8
Symbol	reserved ^[1]		FRINDEX[13:8]					
Reset	0	0	0	0	0	0	0	0
Access	R/W	R/W	R/W	R/W	R/W	R/W	R/W	R/W
Bit	7	6	5	4	3	2	1	0
Symbol	FRINDEX[7:0]							
Reset	0	0	0	0	0	0	0	0
Access	R/W	R/W	R/W	R/W	R/W	R/W	R/W	R/W

[1] The reserved bits should always be written with the reset value.

Table 19: FRINDEX register: bit description

Bit	Symbol	Description ^[1]
31 to 14	-	reserved
13 to 0	FRINDEX[13:0]	Frame Index: Bits in this register are used for the frame number in the SOF packet and as the index into the Frame List. The value in this register increments at the end of each time frame (for example, microframe).

[1] For details on register bit description, refer to *Enhanced Host Controller Interface Specification for Universal Serial Bus Rev. 1.0*.

8.2.5 CTRLDSSEGMENT register (R/W: 0030h)

The Control Data Structure Segment (CTRLDSSEGMENT) register corresponds to the most significant address bits (63 to 32) for all EHCI data structures. If the 64AC (64-bit Addressing Capability) field in HCCPARAMS is cleared, then this register is not used and software cannot write to it (reading from this register returns zero).

If the 64AC (64-bit Addressing Capability) field in HCCPARAMS is set, this register is used with link pointers to construct 64-bit addresses to EHCI control data structures. This register is concatenated with the link pointer from either the PERIODICLISTBASE, ASYNCLISTADDR, or any control data structure link field to construct a 64-bit address.

This register allows the host software to locate all control data structures within the same 4 gigabytes memory segment.

8.2.6 CONFIGFLAG register (R/W: 0060h)

The bit allocation of the Configure Flag (CONFIGFLAG) register is given in [Table 20](#).

Table 20: CONFIGFLAG register: bit allocation

Bit	31	30	29	28	27	26	25	24
Symbol	reserved ^[1]							
Reset	0	0	0	0	0	0	0	0
Access	R/W	R/W	R/W	R/W	R/W	R/W	R/W	R/W

Bit	23	22	21	20	19	18	17	16
Symbol	reserved [1]							
Reset	0	0	0	0	0	0	0	0
Access	R/W	R/W	R/W	R/W	R/W	R/W	R/W	R/W
Bit	15	14	13	12	11	10	9	8
Symbol	reserved [1]							
Reset	0	0	0	0	0	0	0	0
Access	R/W	R/W	R/W	R/W	R/W	R/W	R/W	R/W
Bit	7	6	5	4	3	2	1	0
Symbol	reserved [1]							CF
Reset	0	0	0	0	0	0	0	0
Access	R/W	R/W	R/W	R/W	R/W	R/W	R/W	R/W

[1] The reserved bits should always be written with the reset value.

Table 21: CONFIGFLAG register: bit description

Bit	Symbol	Description [1]
31 to 1	-	reserved
0	CF	Configure Flag: The host software sets this bit as the last action when it is configuring the Host Controller. This bit controls the default port-routing control logic.

[1] For details on register bit description, refer to *Enhanced Host Controller Interface Specification for Universal Serial Bus Rev. 1.0*.

8.2.7 PORTSC1 register (R/W: 0064h)

The Port Status and Control (PORTSC) register (bit allocation: [Table 22](#)) is in the power well. It is reset by hardware only when the auxiliary power is initially applied or in response to a Host Controller reset. The initial conditions of a port are:

- No peripheral connected
- Port disabled.

If the port has power control, software cannot change the state of the port until it sets the port power bits. Software must not attempt to change the state of the port until the power is stable on the port (maximum delay is 20 ms from the transition).

Table 22: PORTSC1 register: bit allocation

Bit	31	30	29	28	27	26	25	24
Symbol	reserved [1]							
Reset	0	0	0	0	0	0	0	0
Access	R/W	R/W	R/W	R/W	R/W	R/W	R/W	R/W
Bit	23	22	21	20	19	18	17	16
Symbol	reserved [1]				PTC[3:0]			
Reset	0	0	0	0	0	0	0	0
Access	R/W	R/W	R/W	R/W	R/W	R/W	R/W	R/W

Bit	15	14	13	12	11	10	9	8
Symbol	PIC[1:0]		PO	PP	LS[1:0]		reserved ^[1]	PR
Reset	0	0	1	0	0	0	0	0
Access	R	R	R/W	R/W	R/W	R/W	R/W	R
Bit	7	6	5	4	3	2	1	0
Symbol	SUSP	FPR	reserved ^[1]			PED	ECSC	ECCS
Reset	0	0	0	0	0	0	0	0
Access	R/W	R/W	R/W	R/W	R/W	R/W	R/W	R

[1] The reserved bits should always be written with the reset value.

Table 23: PORTSC1 register: bit description

Bit	Symbol	Description ^[1]
31 to 20	-	reserved
19 to 16	PTC[3:0]	Port Test Control: When this field is zero, the port is not operating in a test mode. A non-zero value indicates that it is operating in test mode indicated by the value.
15 to 14	PIC[1:0]	Port Indicator Control: Writing to this field has no effect if the P_INDICATOR bit in the HCSPARAMS register is logic 0. For a description on how these bits are implemented, refer to <i>Universal Serial Bus Specification Rev. 2.0</i> . ^[2]
13	PO	Port Owner: This bit unconditionally goes to logic 0 when the configured bit in the CONFIGFLAG register makes a logic 0 to logic 1 transition. This bit unconditionally goes to logic 1 whenever the configured bit is logic 0.
12	PP	Port Power: The function of this bit depends on the value of the PPC (Port Power Control) field in the HCSPARAMS register.
11 to 10	LS[1:0]	Line Status: This field reflect the current logical levels of the DP (bit 11) and DM (bit 10) signal lines.
9	-	reserved
8	PR	Port Reset: Logic 1 means the port is in the reset state. Logic 0 means the port is not in reset. ^[2]
7	SUSP	Suspend: Logic 1 means the port is in the suspend state. Logic 0 means the port is not suspended. ^[2]
6	FPR	Force Port Resume: Logic 1 means resume detected or driven on the port. Logic 0 means no resume (K-state) detected or driven on the port. ^[2]
5 to 3	-	reserved
2	PED	Port Enabled/Disabled: Logic 1 means enable. Logic 0 means disable. ^[2]
1	ECSC	Connect Status Change: Logic 1 means change in ECCS. Logic 0 means no change. ^[2]
0	ECCS	Current Connect Status: Logic 1 indicates a device is present on the port. Logic 0 indicates no device is present. ^[2]

[1] For details on register bit description, refer to *Enhanced Host Controller Interface Specification for Universal Serial Bus Rev. 1.0*.

[2] These fields read logic 0, if the PP (Port Power) bit in register PORTSC1 is logic 0.

8.2.8 ISO PTD Done Map register (R: 0130h)

The bit description of the register is given in [Table 24](#).

Table 24: ISO PTD Done Map register: bit description

Bit	Symbol	Access	Value	Description
31 to 0	ISO_PTD_DONE_MAP[31:0]	R	0000 0000h	ISO PTD Done Map: Done map for each of the 32 PTDs for the ISO transfer

This register represents a direct map of the done status of the 32 PTDs. The bit corresponding to a certain PTD will be set to logic 1 as soon as that PTD execution is completed. Reading the Done Map register will clear all the bits that are set to logic 1, and the next reading will reflect the updated status of new executed PTDs.

8.2.9 ISO PTD Skip Map register (R/W: 0134h)

[Table 25](#) shows the bit description of the register.

Table 25: ISO PTD Skip Map register: bit description

Bit	Symbol	Access	Value	Description
31 to 0	ISO_PTD_SKIP_MAP[31:0]	R/W	FFFF FFFFh	ISO PTD Skip Map: Skip map for each of the 32 PTDs for the ISO transfer.

When a bit in the PTD Skip Map is set to logic 1 that PTD will be skipped although its V bit may be set. The information in that PTD is not processed. For example, NextPTDPointer will not affect the order of processing of PTDs. The Skip bit should not be normally set on the position indicated by NextPTDPointer.

8.2.10 ISO PTD Last PTD register (R/W: 0138h)

[Table 26](#) shows the bit description of the ISO PTD Last PTD register.

Table 26: ISO PTD Last PTD register: bit description

Bit	Symbol	Access	Value	Description
31 to 0	ISO_PTD_LAST_PTD[31:0]	R/W	0000 0000h	ISO PTD last PTD: Last PTD of the 32 PTDs is indicated by the 32 bitmap. 1h — One PTD in ISO 2h — Two PTDs in ISO 4h — Three PTDs in ISO.

Once the LastPTD bit corresponding to a PTD is set, this will be the last PTD processed (checking V = 1) in that PTD category. Subsequently, the process will restart with the first PTD (of that group). This is useful to reduce the time in which all the PTDs (the respective memory space) would be checked, especially if only a few PTDs are defined. The LastPTD bit must be normally set to a higher position than any other position indicated by the NextPTDPointer from an active PTD.

8.2.11 INT PTD Done Map register (R: 0140h)

The bit description of the register is given in [Table 27](#).

Table 27: INT PTD Done Map register: bit description

Bit	Symbol	Access	Value	Description
31 to 0	INT_PTD_DONE_MAP[31:0]	R	0000 0000h	INT PTD Done Map: Done map for each of the 32 PTDs for the INT transfer

This register represents a direct map of the done status of the 32 PTDs. The bit corresponding to a certain PTD will be set to logic 1 as soon as that PTD execution is completed. Reading the Done Map register will clear all the bits that are set to logic 1, and the next reading will reflect the updated status of new executed PTDs.

8.2.12 INT PTD Skip Map register (R/W: 0144h)

[Table 28](#) shows the bit description of the INT PTD Skip Map register.

Table 28: INT PTD Skip Map register: bit description

Bit	Symbol	Access	Value	Description
31 to 0	INT_PTD_SKIP_MAP[31:0]	R/W	FFFF FFFFh	INT PTD Skip Map: Skip map for each of the 32 PTDs for the INT transfer

When a bit in the PTD Skip Map is set to logic 1 that PTD will be skipped although its V bit may be set. The information in that PTD is not processed. For example, NextPTDPointer will not affect the order of processing of PTDs. The Skip bit should not be normally set on the position indicated by NextPTDPointer.

8.2.13 INT PTD Last PTD register (R/W: 0148h)

The bit description of the register is given in [Table 29](#).

Table 29: INT PTD Last PTD register: bit description

Bit	Symbol	Access	Value	Description
31 to 0	INT_PTD_LAST_PTD[31:0]	R/W	0000 0000h	INT PTD Last PTD: Last PTD of the 32 PTDs as indicated by the 32 bitmap. 1h — One PTD in INT 2h — Two PTDs in INT 3h — Three PTDs in INT.

Once the LastPTD bit corresponding to a PTD is set, this will be the last PTD processed (checking V = 1) in that PTD category. Subsequently, the process will restart with the first PTD (of that group). This is useful to reduce the time in which all the PTDs (the respective memory space) would be checked, especially if only a few PTDs are defined. The LastPTD bit must be normally set to a higher position than any other position indicated by the NextPTDPointer from an active PTD.

8.2.14 ATL PTD Done Map register (R: 0150h)

[Table 30](#) shows the bit description of the ATL PTD Done Map register.

Table 30: ATL PTD Done Map register: bit description

Bit	Symbol	Access	Value	Description
31 to 0	ATL_PTD_DONE_MAP[31:0]	R	0000 0000h	ATL PTD Done Map: Done map for each of the 32 PTDs for the ATL transfer

This register represents a direct map of the done status of the 32 PTDs. The bit corresponding to a certain PTD will be set to logic 1 as soon as that PTD execution is completed. Reading the Done Map register will clear all the bits that are set to logic 1, and the next reading will reflect the updated status of new executed PTDs.

8.2.15 ATL PTD Skip Map register (R/W: 0154h)

The bit description of the register is given in [Table 31](#).

Table 31: ATL PTD Skip Map register: bit description

Bit	Symbol	Access	Value	Description
31 to 0	ATL_PTD_SKIP_MAP[31:0]	R/W	FFFF FFFFh	ATL PTD Skip Map: Skip map for each of the 32 PTDs for the ATL transfer

When a bit in the PTD Skip Map is set to logic 1 that PTD will be skipped although its V bit may be set. The information in that PTD is not processed. For example, NextPTDPointer will not affect the order of processing of PTDs. The Skip bit should not be normally set on the position indicated by NextPTDPointer.

8.2.16 ATL PTD Last PTD register (R/W: 0158h)

The bit description of the ATL PTD Last PTD register is given in [Table 32](#).

Table 32: ATL PTD Last PTD register: bit description

Bit	Symbol	Access	Value	Description
31 to 0	ATL_PTD_LAST_PTD[31:0]	R/W	0000 0000h	ATL PTD Last PTD: Last PTD of the 32 PTDs as indicated by the 32 bitmap. 1h — One PTD in ATL 2h — Two PTDs in ATL 4h — Three PTDs in ATL.

Once the LastPTD bit corresponding to a PTD is set, this will be the last PTD processed (checking V = 1) in that PTD category. Subsequently, the process will restart with the first PTD (of that group). This is useful to reduce the time in which all the PTDs (the respective memory space) would be checked, especially if only a few PTDs are defined. The LastPTD bit must be normally set to a higher position than any other position indicated by the NextPTDPointer from an active PTD.

8.3 Configuration registers

8.3.1 HW Mode Control register (R/W: 0300h)

[Table 33](#) shows the bit allocation of the register.

Table 33: HW Mode Control register: bit allocation

Bit	31	30	29	28	27	26	25	24
Symbol	ALL_ATX_RESET	reserved ^[1]						
Reset	0	0	0	0	0	0	0	0
Access	R/W	R/W	R/W	R/W	R/W	R/W	R/W	R/W
Bit	23	22	21	20	19	18	17	16
Symbol	reserved ^[1]							
Reset	0	0	0	0	0	0	0	0
Access	R/W	R/W	R/W	R/W	R/W	R/W	R/W	R/W
Bit	15	14	13	12	11	10	9	8
Symbol	ANA_DIGI_OC	reserved ^[1]						DATA_BUS_WIDTH
Reset	0	0	0	0	0	0	0	1
Access	R/W	R/W	R/W	R/W	R/W	R/W	R/W	R/W

Bit	7	6	5	4	3	2	1	0
Symbol	reserved	DACK_POL	DREQ_POL	reserved [1]		INTR_POL	INTR_LEVEL	GLOBAL_INTR_EN
Reset	0	0	0	0	0	0	0	0
Access	R/W	R/W	R/W	R/W	R/W	R/W	R/W	R/W

[1] The reserved bits should always be written with the reset value.

Table 34: HW Mode Control register: bit description

Bit	Symbol	Description
31	ALL_ATX_RESET	All ATX Reset: For debugging purposes (not used normally). 1 — Enable reset, then write back logic 0 0 — No reset.
30 to 16	-	reserved; write logic 0
15	ANA_DIGI_OC	Analog Digital Overcurrent: This bit selects analog or digital overcurrent detection on pins OC1_N, OC2_N and OC3_N. 0 — Digital overcurrent 1 — Analog overcurrent.
14 to 9	-	reserved; write logic 0
8	DATA_BUS_WIDTH	Data Bus Width: 0 — defines a 16-bit data bus width 1 — sets a 32-bit data bus width.
7	-	reserved; write logic 0
6	DACK_POL	DACK Polarity: 1 — indicates that the DACK input is active HIGH 0 — indicates active LOW.
5	DREQ_POL	DREQ Polarity: 1 — indicates that the DREQ output is active HIGH 0 — indicates active LOW.
4 to 3	-	reserved; write logic 0
2	INTR_POL	Interrupt Polarity: 0 — active LOW 1 — active HIGH.
1	INTR_LEVEL	Interrupt Level: 0 — INT level triggered 1 — INT is edge triggered. A pulse of certain width is generated.
0	GLOBAL_INTR_EN	Global Interrupt Enable: This bit must be set to logic 1 to enable the IRQ signal assertion. 0 — IRQ assertion is disabled. IRQ will never be asserted, regardless of other settings or IRQ events. 1 — IRQ assertion is enabled. IRQ will be asserted according to the Interrupt Enable register, and events setting and occurrence.

8.3.2 Chip ID register (R: 0304h)

Read this register to get the ID of the ISP1760. The upper word of the register contains the hardware version number and the lower word contains the chip ID. [Table 35](#) shows the bit description of the register.

Table 35: Chip ID register: bit description

Bit	Symbol	Access	Value	Description
31 to 0	CHIPID [31:0]	R	0001 1761h	Chip ID: This register represents the hardware version number (0001h) and the chip ID (1761h). Remark: The chip ID is for internal use to identify the ISP176x product family.

8.3.3 Scratch register (R/W: 0308h)

This register is for testing and debugging purposes only. The value read back must be the same as the value that was written. The bit description of this register is given in [Table 36](#).

Table 36: Scratch register: bit description

Bit	Symbol	Access	Value	Description
31 to 0	SCRATCH[31:0]	R/W	0000 0000h	Scratch: For testing and debugging purposes

8.3.4 SW Reset register (R/W: 030Ch)

[Table 37](#) shows the bit allocation of the register.

Table 37: SW Reset register: bit allocation

Bit	31	30	29	28	27	26	25	24
Symbol	reserved ^[1]							
Reset	0	0	0	0	0	0	0	0
Access	R/W	R/W	R/W	R/W	R/W	R/W	R/W	R/W
Bit	23	22	21	20	19	18	17	16
Symbol	reserved ^[1]							
Reset	0	0	0	0	0	0	0	0
Access	R/W	R/W	R/W	R/W	R/W	R/W	R/W	R/W
Bit	15	14	13	12	11	10	9	8
Symbol	reserved ^[1]							
Reset	0	0	0	0	0	0	0	0
Access	R/W	R/W	R/W	R/W	R/W	R/W	R/W	R/W
Bit	7	6	5	4	3	2	1	0
Symbol	reserved ^[1]						RESET_ HC	RESET_ ALL
Reset	0	0	0	0	0	0	0	0
Access	R/W	R/W	R/W	R/W	R/W	R/W	R/W	R/W

[1] The reserved bits should always be written with the reset value.

Table 38: SW Reset register: bit description

Bit	Symbol	Description
31 to 2	-	reserved; write logic 0
1	RESET_HC	Reset Host Controller: Reset only the Host Controller-specific registers (only registers with address below 300h). 0 — No reset 1 — Enable reset.
0	RESET_ALL	Reset All: Reset all the Host Controller and CPU interface registers. 0 — No reset 1 — Enable reset.

8.3.5 DMA Configuration register (R/W: 0330h)

The bit allocation of the DMA Configuration register is given in [Table 39](#).

Table 39: DMA Configuration register: bit allocation

Bit	31	30	29	28	27	26	25	24	
Symbol	DMA_COUNTER[23:16]								
Reset	0	0	0	0	0	0	0	0	
Access	R/W	R/W	R/W	R/W	R/W	R/W	R/W	R/W	
Bit	23	22	21	20	19	18	17	16	
Symbol	DMA_COUNTER[15:8]								
Reset	0	0	0	0	0	0	0	0	
Access	R/W	R/W	R/W	R/W	R/W	R/W	R/W	R/W	
Bit	15	14	13	12	11	10	9	8	
Symbol	DMA_COUNTER[7:0]								
Reset	0	0	0	0	0	0	0	0	
Access	R/W	R/W	R/W	R/W	R/W	R/W	R/W	R/W	
Bit	7	6	5	4	3	2	1	0	
Symbol	reserved ^[1]				BURST_LEN[1:0]		ENABLE_DMA	DMA_READ_WRITE_SEL	
Reset	0	0	0	0	0	0	0	0	
Access	R/W	R/W	R/W	R/W	R/W	R/W	R/W	R/W	

[1] The reserved bits should always be written with the reset value.

Table 40: DMA Configuration register: bit description

Bit	Symbol	Description
31 to 8	DMA_COUNTER [23:0]	DMA Counter: The number of bytes to be transferred (read or write). Remark: Different number of bursts will be generated for the same transfer length programmed in 16-bit and 32-bit modes because DMA_COUNTER is in number of bytes.
7 to 4	-	reserved
3 to 2	BURST_LEN[1:0]	DMA Burst Length: 00 — Single DMA burst 01 — 4-cycle DMA burst 10 — 8-cycle DMA burst 11 — 16-cycle DMA burst.
1	ENABLE_DMA	Enable DMA: 0 — Terminate DMA 1 — Enable DMA.
0	DMA_READ_WRITE_SEL	DMA Read/Write Select: Indicates if the DMA operation is a write or read (to or from the ISP1760). 0 — DMA write to the ISP1760 internal RAM is set 1 — DMA read from the ISP1760 internal RAM.

8.3.6 Buffer Status register (R/W: 0334h)

Table 41 shows the bit allocation of the Buffer Status register.

Table 41: Buffer Status register: bit allocation

Bit	31	30	29	28	27	26	25	24	
Symbol	reserved [1]								
Reset	0	0	0	0	0	0	0	0	
Access	R/W	R/W	R/W	R/W	R/W	R/W	R/W	R/W	
Bit	23	22	21	20	19	18	17	16	
Symbol	reserved [1]								
Reset	0	0	0	0	0	0	0	0	
Access	R/W	R/W	R/W	R/W	R/W	R/W	R/W	R/W	
Bit	15	14	13	12	11	10	9	8	
Symbol	reserved [1]								
Reset	0	0	0	0	0	0	0	0	
Access	R/W	R/W	R/W	R/W	R/W	R/W	R/W	R/W	
Bit	7	6	5	4	3	2	1	0	
Symbol	reserved [1]					ISO_BUF_ FILL	INT_BUF_ FILL	ATL_BUF_ FILL	
Reset	0	0	0	0	0	0	0	0	
Access	R/W	R/W	R/W	R/W	R/W	R/W	R/W	R/W	

[1] The reserved bits should always be written with the reset value.

Table 42: Buffer Status register: bit description

Bit	Symbol	Description
31 to 3	-	reserved
2	ISO_BUF_FILL	ISO Buffer Filled: 1 — Indicates one of the ISO PTDs is filled, and the ISO PTD area will be processed 0 — Indicates there is no PTD in this area. Therefore, processing of the ISO PTDs will be completely skipped.
1	INT_BUF_FILL	INT Buffer Filled: 1 — Indicates one of the INT PTDs is filled, and the INT PTD area will be processed 0 — Indicates there is no PTD in this area. Therefore, processing of the INT PTDs will be completely skipped.
0	ATL_BUF_FILL	ATL Buffer Filled: 1 — Indicates one of the ATL PTDs is filled, and the ATL PTD area will be processed 0 — Indicates there is no PTD in this area. Therefore, processing of the ATL PTDs will be completely skipped.

8.3.7 ATL Done Timeout register (R/W: 0338h)

The bit description of the ATL Done Timeout register is given in [Table 43](#).

Table 43: ATL Done Timeout register: bit description

Bit	Symbol	Access	Value	Description
31 to 0	ATL_DONE_TIMEOUT [31:0]	R/W	0000 0000h	ATL Done Timeout: This register determines the ATL done timeout interrupt. This register defines the timeout in ms after which the ISP1760 asserts the INT line, if enabled. It is applicable to the ATL done PTDs only.

8.3.8 Memory register (R/W: 033Ch)

The Memory register contains the base memory read address and the respective bank. This register needs to be set only before a first memory read cycle. Once written, the address will be latched for the bank and will be incremented for every read of that bank, until a new address for that bank is written to change the address pointer.

The bit description of the register is given in [Table 44](#).

Table 44: Memory register: bit allocation

Bit	31	30	29	28	27	26	25	24
Symbol	reserved [1]							
Reset	0	0	0	0	0	0	0	0
Access	R/W	R/W	R/W	R/W	R/W	R/W	R/W	R/W
Bit	23	22	21	20	19	18	17	16
Symbol	reserved [1]						MEM_BANK_SEL[1:0]	
Reset	0	0	0	0	0	0	0	0
Access	R/W	R/W	R/W	R/W	R/W	R/W	R/W	R/W

Bit	15	14	13	12	11	10	9	8
Symbol	START_ADDR_MEM_READ[15:8]							
Reset	0	0	0	0	0	0	0	0
Access	R/W	R/W	R/W	R/W	R/W	R/W	R/W	R/W
Bit	7	6	5	4	3	2	1	0
Symbol	START_ADDR_MEM_READ[7:0]							
Reset	0	0	0	0	0	0	0	0
Access	R/W	R/W	R/W	R/W	R/W	R/W	R/W	R/W

[1] The reserved bits should always be written with the reset value.

Table 45: Memory register: bit description

Bit	Symbol	Description
31 to 18	-	reserved
17 to 16	MEM_BANK_SEL[1:0]	Memory Bank Select: Up to four memory banks can be selected. For details on internal memory read description, see Section 7.3.1 . Applicable to PIO mode memory read or write data transfers only.
15 to 0	START_ADDR_MEM_READ[15:0]	Start Address for Memory Read Cycles: The start address for a series of memory read cycles at incremental addresses in a contiguous space. Applicable to PIO mode memory read data transfers only.

8.3.9 Edge Interrupt Count register (R/W: 0340h)

[Table 46](#) shows the bit allocation of the register.

Table 46: Edge Interrupt Count register: bit allocation

Bit	31	30	29	28	27	26	25	24
Symbol	MIN_WIDTH[7:0]							
Reset	0	0	0	0	0	0	0	0
Access	R/W	R/W	R/W	R/W	R/W	R/W	R/W	R/W
Bit	23	22	21	20	19	18	17	16
Symbol	reserved ^[1]							
Reset	0	0	0	0	0	0	0	0
Access	R/W	R/W	R/W	R/W	R/W	R/W	R/W	R/W
Bit	15	14	13	12	11	10	9	8
Symbol	NO_OF_CLK[15:8]							
Reset	0	0	0	0	0	0	0	0
Access	R/W	R/W	R/W	R/W	R/W	R/W	R/W	R/W
Bit	7	6	5	4	3	2	1	0
Symbol	NO_OF_CLK[7:0]							
Reset	0	0	0	0	1	1	1	1
Access	R/W	R/W	R/W	R/W	R/W	R/W	R/W	R/W

[1] The reserved bits should always be written with the reset value.

Table 47: Edge Interrupt Count register: bit description

Bit	Symbol	Description
31 to 24	MIN_WIDTH[7:0]	Minimum Width: Indicates the minimum width between two edge interrupts in μ SOFs (1 μ SOF = 125 μ s). This is not valid for level interrupts. A count of zero means that interrupts occur as and when an event occurs.
23 to 16	-	reserved
15 to 0	NO_OF_CLK[15:0]	Number of Clocks: Count in number of clocks that the edge interrupt must be kept asserted on the interface. The default IRQ pulse width is approximately 500 ns.

8.3.10 DMA Start Address register (W: 0344h)

This register defines the start address select for the DMA read and write operations. See [Table 48](#) for the bit allocation.

Table 48: DMA Start Address register: bit allocation

Bit	31	30	29	28	27	26	25	24
Symbol	reserved [1]							
Reset	0	0	0	0	0	0	0	0
Access	W	W	W	W	W	W	W	W
Bit	23	22	21	20	19	18	17	16
Symbol	reserved [1]							
Reset	0	0	0	0	0	0	0	0
Access	W	W	W	W	W	W	W	W
Bit	15	14	13	12	11	10	9	8
Symbol	START_ADDR_DMA[15:8]							
Reset	0	0	0	0	0	0	0	0
Access	W	W	W	W	W	W	W	W
Bit	7	6	5	4	3	2	1	0
Symbol	START_ADDR_DMA[7:0]							
Reset	0	0	0	0	0	0	0	0
Access	W	W	W	W	W	W	W	W

[1] The reserved bits should always be written with the reset value.

Table 49: DMA Start Address register: bit description

Bit	Symbol	Description
31 to 16	-	reserved
15 to 0	START_ADDR_DMA[15:0]	Start Address for DMA: The start address for DMA read or write cycles.

8.3.11 Power Down Control register (R/W: 0354h)

This register is used to turn off power to the internal blocks of the ISP1760 to obtain maximum power savings. [Table 50](#) shows the bit allocation of the register.

Table 50: Power Down Control register: bit allocation

Bit	31	30	29	28	27	26	25	24
Symbol	CLK_OFF_COUNTER[15:8]							
Reset	0	0	0	0	0	0	1	1
Access	R/W	R/W	R/W	R/W	R/W	R/W	R/W	R/W
Bit	23	22	21	20	19	18	17	16
Symbol	CLK_OFF_COUNTER[7:0]							
Reset	1	1	1	0	1	0	0	0
Access	R/W	R/W	R/W	R/W	R/W	R/W	R/W	R/W
Bit	15	14	13	12	11	10	9	8
Symbol	reserved [1]			PORT3_PD	PORT2_PD	VBATDET_PWR	reserved [1]	
Reset	0	0	0	1	1	0	1	1
Access	R/W	R/W	R/W	R/W	R/W	R/W	R/W	R/W
Bit	7	6	5	4	3	2	1	0
Symbol	reserved [1]		BIASEN	VREG_ON	OC3_PWR	OC2_PWR	OC1_PWR	HC_CLK_EN
Reset	1	0	1	0	0	0	0	0
Access	R/W	R/W	R/W	R/W	R/W	R/W	R/W	R/W

[1] The reserved bits should always be written with the reset value.

Table 51: Power Down Control register: bit description

Bit [1]	Symbol	Description
31 to 16	CLK_OFF_COUNTER [15:0]	<p>Clock Off Counter: Determines the wake-up status duration after any wake-up event before the ISP1760 goes back into suspend mode. This timeout is applicable only if, during the given interval, the Host Controller is not programmed back to the normal functionality.</p> <p>03E8h — The default value. It determines the default wake-up interval of 10 ms. A value of zero implies that the Host Controller never wakes up on any of the events. This may be useful when using the ISP1760 as a peripheral to save power by permanently programming the Host Controller in suspend.</p> <p>FFFFh — The maximum value. It determines a maximum wake-up time of 500 ms.</p> <p>The setting of this register is based on the 100 kHz ± 40 % LazyClock frequency. It is a multiple of 10 µs period. In 16-bit mode, a write operation to these bits with any value will determine a fixed wake-up time of 50 ms.</p>
15 to 13	-	reserved
12	PORT3_PD	<p>Port 3 Pull-Down: Controls port 3 pull-down resistors.</p> <p>0 — Port 3 pull-down resistors are connected in suspend</p> <p>1 — Port 3 pull-down resistors are not connected in suspend.</p>
11	PORT2_PD	<p>Port 2 Pull-Down: Controls port 2 pull-down resistors.</p> <p>0 — Port 2 internal pull-down resistors are connected in suspend</p> <p>1 — Port 2 internal pull-down resistors are not connected in suspend.</p>

Table 51: Power Down Control register: bit description...continued

Bit [1]	Symbol	Description
10	VBATDET_PWR	V_{BAT} Detector Powered: Controls the power to the V _{BAT} detector. 0 — V _{BAT} detector is powered or enabled in suspend 1 — V _{BAT} detector is not powered or disabled in suspend.
9 to 6	-	reserved; write logic 0
5	BIASEN	BIAS Circuits Powered: Controls the power to internal BIAS circuits. 0 — Internal BIAS circuits are not powered in suspend 1 — Internal BIAS circuits are powered in suspend.
4	VREG_ON	V_{REG} Powered: Enables or disables the internal 3.3 V and 1.8 V regulators when the ISP1760 is in suspend. 0 — Internal regulators are powered in suspend 1 — Internal regulators are not powered in suspend.
3	OC3_PWR	OC3_N Powered: Controls the powering of the overcurrent detection circuitry for port 3. 0 — Overcurrent detection is powered on or enabled during suspend. 1 — Overcurrent detection is powered off or disabled during suspend. This may be useful when connecting a faulty device while the system is in standby.
2	OC2_PWR	OC2_N Powered: Controls the powering of the overcurrent detection circuitry for port 2. 0 — Overcurrent detection powered-on or enabled during suspend. 1 — Overcurrent detection powered-off or disabled during suspend. This may be useful when connecting a faulty device while the system is in standby.
1	OC1_PWR	OC1_N Powered: Controls the powering of the overcurrent detection circuitry for port 1. 0 — Overcurrent detection powered-on or enabled during suspend. 1 — Overcurrent detection powered-off or disabled during suspend. This may be useful when connecting a faulty device while the system is in standby.
0	HC_CLK_EN	Host Controller Clock Enabled: Controls internal clocks during suspend. 0 — Clocks are disabled during suspend. This is the default value. Only the LazyClock of 100 kHz ± 40 % will be left running in suspend if this bit is logic 0. If clocks are stopped during suspend, CLKREADY IRQ will be generated when all clocks are running stable. 1 — All clocks are enabled even in suspend.

[1] For a 32-bit operation, the default wake-up counter value is 10 μs. For a 16-bit operation, the wake-up counter value is 50 ms. In the 16-bit operation, read and write back the same value on initialization.

8.3.12 Port 1 Control register (R/W: 0374h)

The values read from the lower 16 bits and the upper 16 bits of this register are always the same. [Table 52](#) shows the bit allocation of the register.

Table 52: Port 1 Control register: bit allocation

Bit	31	30	29	28	27	26	25	24
Symbol	reserved [1]							
Reset	0	0	0	0	0	0	0	0
Access	R/W	R/W	R/W	R/W	R/W	R/W	R/W	R/W
Bit	23	22	21	20	19	18	17	16
Symbol	PORT1_ INIT2	reserved [1]						
Reset	1	0	0	0	0	1	1	0
Access	R/W	R/W	R/W	R/W	R/W	R/W	R/W	R/W
Bit	15	14	13	12	11	10	9	8
Symbol	reserved [1]							
Reset	0	0	0	0	0	0	0	0
Access	R/W	R/W	R/W	R/W	R/W	R/W	R/W	R/W
Bit	7	6	5	4	3	2	1	0
Symbol	PORT1_ INIT1	reserved [1]		PORT1_POWER[1:0]		reserved [1]		
Reset	0	0	0	1	0	1	1	0
Access	R/W	R/W	R/W	R/W	R/W	R/W	R/W	R/W

[1] The reserved bits should always be written with the reset value.

Table 53: Port 1 Control register: bit description

Bit [1]	Symbol	Description
31 to 24	-	reserved; write logic 0
23	PORT1_ INIT2	Port 1 Initialization 2: Write logic 1 at the ISP1760 initialization. It will clear both this bit and bit 7. Affects only port 1.
22 to 8	-	reserved; write logic 0
7	PORT1_ INIT1	Port 1 Initialization 1: Must be reset to logic 0 at power-up initialization for correct operation of port 1. Correct Host Controller functionality is not ensured if set to logic 1 (affects only port 1). To clear this bit, logic 1 must be written to bit 23 during the ISP1760 initialization. This is not required for the normal functionality of port 2 and port 3.
6 to 5	-	reserved
4 to 3	PORT1_ POWER[1:0]	Port 1 Power: Set these bits to 11b. These bits must be set to enable port 1 power.
2 to 0	-	reserved; write logic 0

[1] For correct port 1 initialization, write 0080 0018h to this register after power on.

8.4 Interrupt registers

8.4.1 Interrupt register (R/W: 0310h)

The bits of this register indicate the interrupt source, defining the events that determined the INT generation. Clearing the bits that were set because of the events listed is done by writing back logic 1 to the respective position. All bits must be reset before enabling new interrupt events. These bits will be set, regardless of the setting of bit GLOBAL_INTR_EN in the HW Mode Control register. [Table 54](#) shows the bit allocation of the Interrupt register.

Table 54: Interrupt register: bit allocation

Bit	31	30	29	28	27	26	25	24
Symbol	reserved ^[1]							
Reset	0	0	0	0	0	0	0	0
Access	R/W	R/W	R/W	R/W	R/W	R/W	R/W	R/W
Bit	23	22	21	20	19	18	17	16
Symbol	reserved ^[1]							
Reset	0	0	0	0	0	0	0	0
Access	R/W	R/W	R/W	R/W	R/W	R/W	R/W	R/W
Bit	15	14	13	12	11	10	9	8
Symbol	reserved ^[1]						ISO_IRQ	ATL_IRQ
Reset	0	0	0	0	0	0	0	0
Access	R/W	R/W	R/W	R/W	R/W	R/W	R/W	R/W
Bit	7	6	5	4	3	2	1	0
Symbol	INT_IRQ	CLK READY	HC_SUSP	reserved ^[1]	DMA EOTINT	reserved ^[1]		SOFITLINT
Reset	0	0	0	0	0	0	0	0
Access	R/W	R/W	R/W	R/W	R/W	R/W	R/W	R/W

[1] The reserved bits should always be written with the reset value.

Table 55: Interrupt register: bit description

Bit	Symbol	Description
31 to 10	-	reserved; write logic 0
9	ISO_IRQ	<p>ISO IRQ: Indicates that an IRQ was asserted because an ISO PTD was completed, or the PTDs corresponding to the bits set in the ISO IRQ Mask AND or ISO IRQ Mask OR register bits combination were completed.</p> <p>0 — No IRQ assertion determined by the completion of ISO PTDs</p> <p>1 — IRQ asserted because of completing ISO PTDs.</p> <p>For details, see Section 7.4.</p>
8	ATL_IRQ	<p>ATL IRQ: Indicates that an IRQ was asserted because an ATL PTD was completed, or the PTDs corresponding to the bits set in the ATL IRQ Mask AND or ATL IRQ Mask OR register bits combination were completed.</p> <p>0 — No IRQ assertion determined by the completion of ATL PTDs</p> <p>1 — IRQ asserted because of completing ATL PTD.</p> <p>For details, see Section 7.4.</p>

Table 55: Interrupt register: bit description...continued

Bit	Symbol	Description
7	INT_IRQ	INT IRQ: Indicates that an IRQ was asserted because an INT PTD was completed, or the PTDs corresponding to the bits set in the INT IRQ Mask AND or INT IRQ Mask OR register bits combination were completed. 0 — No IRQ assertion determined by the completion of INT PTDs 1 — IRQ asserted because of completing INT PTD. For details, see Section 7.4 .
6	CLKREADY	Clock Ready: Indicates that an IRQ was asserted as the internal clock signals are running stable. Useful after a power-on or wake-up cycle. 0 — No CLKREADY event has occurred 1 — INT generated because of a CLKREADY event.
5	HC_SUSP	Host Controller Suspend: Indicates that the Host Controller has entered suspend mode. 0 — No INT generated because of the Host Controller entering suspend mode 1 — INT generated because of the Host Controller entering suspend mode. If the ISR accesses the ISP1760, it will wake up for the time specified in bits 31 to 16 of the Power Down Control register.
4	-	reserved; write logic 0
3	DMAEOT INT	DMA EOT Interrupt: Indicates DMA transfer completion. 0 — DMA transfer is not complete 1 — IRQ asserted because the DMA transfer is complete.
2 to 1	-	reserved; write logic 0
0	SOFITLINT	SOT ITL Interrupt: 0 — No SOF event has occurred 1 — An SOF event has occurred.

8.4.2 Interrupt Enable register (R/W: 0314h)

This register allows enabling or disabling of the IRQ generation because of various events as described in [Table 56](#).

Table 56: Interrupt Enable register: bit allocation

Bit	31	30	29	28	27	26	25	24
Symbol	reserved ^[1]							
Reset	0	0	0	0	0	0	0	0
Access	R/W	R/W	R/W	R/W	R/W	R/W	R/W	R/W
Bit	23	22	21	20	19	18	17	16
Symbol	reserved ^[1]							
Reset	0	0	0	0	0	0	0	0
Access	R/W	R/W	R/W	R/W	R/W	R/W	R/W	R/W

Bit	15	14	13	12	11	10	9	8
Symbol	reserved [1]						ISO_IRQ_E	ATL_IRQ_E
Reset	0	0	0	0	0	0	0	0
Access	R/W	R/W	R/W	R/W	R/W	R/W	R/W	R/W
Bit	7	6	5	4	3	2	1	0
Symbol	INT_IRQ_E	CLK_READY_E	HCSUSP_E	reserved [1]	DMAEOT_INT_E	reserved [1]		SOFITLINT_E
Reset	0	0	0	0	0	0	0	0
Access	R/W	R/W	R/W	R/W	R/W	R/W	R/W	R/W

[1] The reserved bits should always be written with the reset value.

Table 57: Interrupt Enable register: bit description

Bit	Symbol	Description
31 to 10	-	reserved; write logic 0
9	ISO_IRQ_E	<p>ISO IRQ Enable: Controls the IRQ assertion because of completing one or more ISO PTDs matching the ISO IRQ Mask AND or ISO IRQ Mask OR register bits combination.</p> <p>0 — No IRQ will be asserted because of completing ISO PTDs</p> <p>1 — IRQ will be asserted.</p> <p>For details, see Section 7.4.</p>
8	ATL_IRQ_E	<p>ATL IRQ Enable: Controls the IRQ assertion because of completing one or more ATL PTDs matching the ATL IRQ Mask AND or ATL IRQ Mask OR register bits combination.</p> <p>0 — No IRQ will be asserted because of completing ATL PTDs</p> <p>1 — IRQ will be asserted.</p> <p>For details, see Section 7.4.</p>
7	INT_IRQ_E	<p>INT IRQ Enable: Controls the IRQ assertion because of completing one or more INT PTDs matching the INT IRQ Mask AND or INT IRQ Mask OR register bits combination.</p> <p>0 — No IRQ will be asserted because of completing INT PTDs</p> <p>1 — IRQ will be asserted.</p> <p>For details, see Section 7.4.</p>
6	CLKREADY_E	<p>Clock Ready Enable: Enables the IRQ assertion when internal clock signals are running stable. Useful after power-on or wake-up.</p> <p>0 — No IRQ will be generated after a CLKREADY_E event has occurred</p> <p>1 — IRQ will be generated after a CLKREADY_E event.</p>
5	HCSUSP_E	<p>Host Controller Suspend Enable: Enables the IRQ generation when the Host Controller enters suspend mode.</p> <p>0 — No IRQ will be generated because of the Host Controller entering suspend mode</p> <p>1 — IRQ will be generated at the Host Controller entering suspend mode.</p>

Table 57: Interrupt Enable register: bit description...continued

Bit	Symbol	Description
4	-	reserved; write logic 0
3	DMAEOT INT_E	DMA EOT Interrupt Enable: Controls assertion of IRQ on the DMA transfer completion. 0 — No IRQ will be generated after the DMA transfer is completed 1 — IRQ will be asserted because of the DMA transfer completion.
2 to 1	-	reserved; must be written with logic 0
0	SOFITLINT _E	SOT ITL Interrupt Enable: Controls the IRQ generation at every SOF occurrence. 0 — No IRQ will be generated on an SOF occurrence 1 — IRQ will be asserted at every SOF.

8.4.3 ISO IRQ Mask OR register (R/W: 0318h)

Each bit of this register corresponds to one of the 32 ISO PTDs defined, and is a hardware IRQ mask for each PTD done map. See [Table 58](#) for bit description. For details, see [Section 7.4](#).

Table 58: ISO IRQ Mask OR register: bit description

Bit	Symbol	Access	Value	Description
31 to 0	ISO_IRQ_ MASK_OR [31:0]	R/W	0000 0000h	ISO IRQ Mask OR: Represents a direct map for ISO PTDs 31 to 0. 0 — No OR condition defined between ISO PTDs 1 — The bits corresponding to certain PTDs are set to logic 1 to define a certain OR condition.

8.4.4 INT IRQ Mask OR register (R/W: 031Ch)

Each bit of this register (see [Table 59](#)) corresponds to one of the 32 INT PTDs defined, and is a hardware IRQ mask for each PTD done map. For details, see [Section 7.4](#).

Table 59: INT IRQ Mask OR register: bit description

Bit	Symbol	Access	Value	Description
31 to 0	INT_IRQ_ MASK_OR [31:0]	R/W	0000 0000h	INT IRQ Mask OR: Represents a direct map for INT PTDs 31 to 0. 0 — No OR condition defined between INT PTDs 31 to 0 1 — The bits corresponding to certain PTDs are set to logic 1 to define a certain OR condition.

8.4.5 ATL IRQ Mask OR register (R/W: 0320h)

Each bit of this register corresponds to one of the 32 ATL PTDs defined, and is a hardware IRQ mask for each PTD done map. See [Table 60](#) for bit description. For details, see [Section 7.4](#).

Table 60: ATL IRQ Mask OR register: bit description

Bit	Symbol	Access	Value	Description
31 to 0	ATL_IRQ_MASK_OR [31:0]	R/W	0000 0000h	ATL IRQ Mask OR: Represents a direct map for ATL PTDs 31 to 0. 0 — No OR condition defined between the ATL PTDs 1 — The bits corresponding to certain PTDs are set to logic 1 to define a certain OR condition.

8.4.6 ISO IRQ Mask AND register (R/W: 0324h)

Each bit of this register corresponds to one of the 32 ISO PTDs defined, and is a hardware IRQ mask for each PTD done map. For details, see [Section 7.4](#).

[Table 61](#) provides the bit description of the register.

Table 61: ISO IRQ Mask AND register: bit description

Bit	Symbol	Access	Value	Description
31 to 0	ISO_IRQ_MASK_AND [31:0]	R/W	0000 0000h	ISO IRQ Mask AND: Represents a direct map for ISO PTDs 31 to 0. 0 — No AND condition defined between ISO PTDs 1 — The bits corresponding to certain PTDs are set to logic 1 to define a certain AND condition between the 32 INT PTDs.

8.4.7 INT IRQ Mask AND register (R/W: 0328h)

Each bit of this register (see [Table 62](#)) corresponds to one of the 32 INT PTDs defined, and is a hardware IRQ mask for each PTD done map. For details, see [Section 7.4](#).

Table 62: INT IRQ Mask AND register: bit description

Bit	Symbol	Access	Value	Description
31 to 0	INT_IRQ_MASK_AND [31:0]	R/W	0000 0000h	INT IRQ Mask AND: Represents a direct map for INT PTDs 31 to 0. 0 — No OR condition defined between INT PTDs 1 — The bits corresponding to certain PTDs are set to logic 1 to define a certain AND condition between the 32 INT PTDs.

8.4.8 ATL IRQ Mask AND register (R/W: 032Ch)

Each bit of this register corresponds to one of the 32 ATL PTDs defined, and is a hardware IRQ mask for each PTD done map. For details, see [Section 7.4](#).

[Table 63](#) shows the bit description of the register.

Table 63: ATL IRQ Mask AND register: bit description

Bit	Symbol	Access	Value	Description
31 to 0	ATL_IRQ_MASK_AND[31:0]	R/W	0000 0000h	<p>ATL IRQ Mask AND: Represents a direct map for ATL PTDs 31 to 0.</p> <p>0 — No OR condition defined between ATL PTDs</p> <p>1 — The bits corresponding to certain PTDs are set to logic 1 to define a certain AND condition between the 32 ATL PTDs.</p>

9. Philips Transfer Descriptor

The standard EHCI data structures as described in *Enhanced Host Controller Interface Specification for Universal Serial Bus Rev. 1.0* are optimized for the bus master operation that is managed by the hardware state machine.

The PTD structures of the ISP1760 are translations of the EHCI data structures that are optimized for the ISP1760, while keeping the architecture of the EHCI data structures the same. This is because the ISP1760 is a slave Host Controller and has no bus master capability.

EHCI manages schedules in two lists: periodic and asynchronous. The data structures are designed to provide the maximum flexibility required by USB, minimize memory traffic, and hardware and software complexity. The ISP1760 controller executes transactions for devices by using a simple shared-memory schedule. This schedule consists of data structures organized into three lists.

qISO — Isochronous transfer

qINTL — Interrupt transfer

qATL — Asynchronous transfer; for the control and bulk transfers.

The system software maintains two lists for the Host Controller: periodic and asynchronous. The root of the periodic schedule—the PERIODICLISTBASE register—is the physical memory base address of the periodic frame list. The periodic frame list is an array memory pointer. The objects referenced from the frame list must be valid schedule data structures. The asynchronous list base is also a common list of queue heads (endpoints) that are served in a schedule. These endpoint data structures are further linked to the EHCI transfer descriptor that is the valid schedule (queue PTD).

The Periodic Schedule Enable (ISO_BUF_FULL and INT_BUF_FULL) or Asynchronous Schedule Enable (ATL_BUF_FULL) bits can enable traversal to these lists. Enabling a list indicates the presence of valid schedule in the list. The system software starts at these points, schedules the first transfer inside the shared memory of the ISP1760, and sets up the ATL, INTL or ITL bit corresponding to the type of transfer scheduled in the shared memory.

The ISP1760 has a maximum of 32 ISO, 32 INTL and 32 ATL PTDs. These PTDs are used as channels to transfer data from the shared memory to the USB bus. These channels are allocated and deallocated on receiving the transfer from the core USB driver.

Multiple transfers are scheduled to the shared memory for various endpoints by traversing the next link pointer provided by the EHCI data structure, until it reaches the terminate bit in a microframe. If a schedule is enabled, the Host Controller starts executing from the ISO schedule, before it goes to the INTL schedule, and then to the ATL schedule.

The EHCI periodic and asynchronous lists are traversed by the software according to the EHCI traversal rule, and executed only from the asynchronous schedule after it encounters the end of the periodic schedule. The Host Controller traverses the ISO, INTL and ATL schedules. It fetches the element and begins traversing the graph of linked schedule data structures.

The last bit identifies the end of the schedule for each type of transfer, indicating the rest of the channels are empty. Once a transition is completed, the Host Controller executes from the next transfer descriptor in the schedule until the end of the microframe.

The completion of a transfer is indicated to the software by the interrupt that can be grouped over the various PTDs by using the AND or OR registers that are available for each schedule type (ISO, INTL and ATL). These registers are simple logic registers to decide the group and individual PTDs that can interrupt the CPU for a schedule, when the logical conditions of the done bit is true in the shared memory that completes the interrupt.

Interrupts are of four types and the latency can be programmed in multiples of μ SOF (125 μ s).

- ISO interrupt
- INTL interrupt
- ATL Interrupt
- SOF—start of frame interrupt for the data transfer.

A static PTD that schedules inside the ISP1760 shared memory allows using the NextPTD mechanism that will enable the Host Controller driver to schedule the multiple PTDs that are of single endpoint and reduce the interrupt to the CPU.

The NextPTD traversal rules defined by the ISP1760 hardware are:

1. Start the ATL header traversal.
2. If the current PTD is active and not done, perform the transaction.
3. Follow the next link pointer.
4. If PTD is not active and done, jump to the next PTD.
5. If the next link pointer is NULL, it means the end of the traversal.

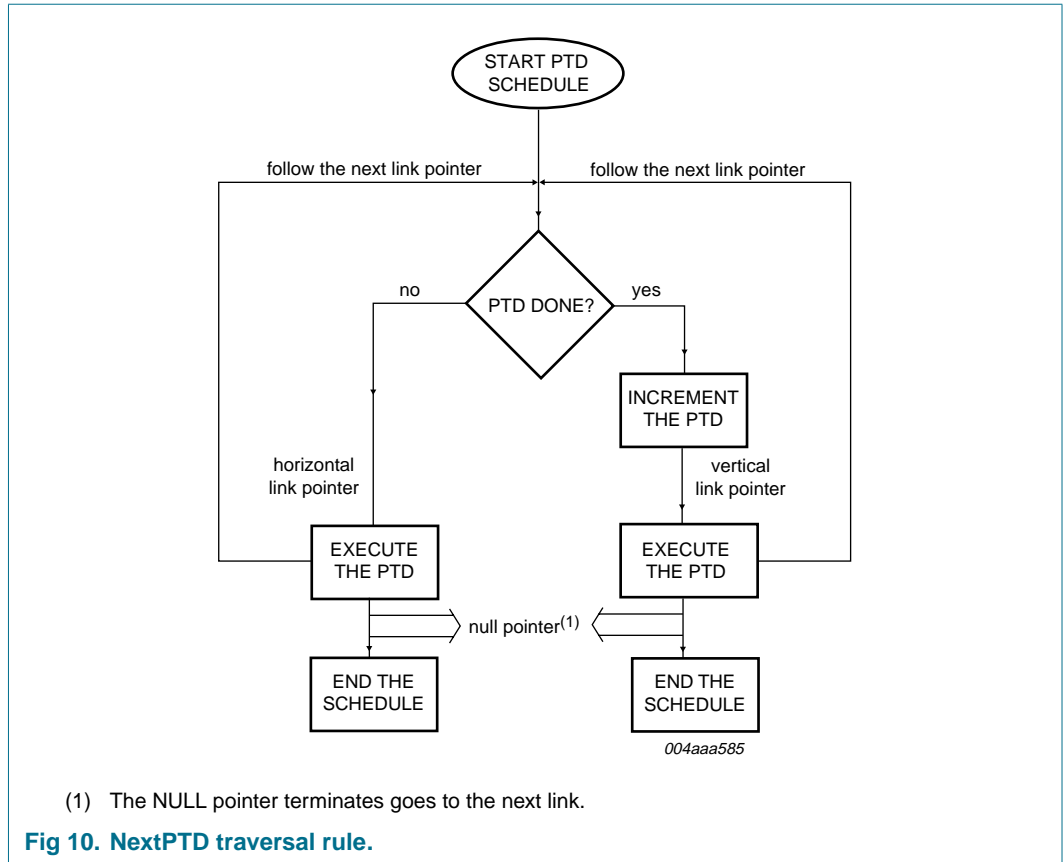

9.1 High-speed bulk IN and OUT, Queue Head Asynchronous (QHA) (patent-pending)

Table 64: High-speed bulk IN and OUT, QHA: bit allocation

Bit	63	62	61	60	59	58	57	56	55	54	53	52	51	50	49	48	47	46	45	44	43	42	41	40	39	38	37	36	35	34	33	32
DW7	reserved																															
DW5	reserved																															
DW3	A	H	B	X	[1]	P	D T	Cerr [1:0]	NakCnt[3:0]			reserved			NrBytesTransferred[14:0] (32 kbytes for high-speed)																	
DW1	reserved													S	EP Type [1:0]	Token [1:0]	DeviceAddress[6:0]						EndPt[3:0] 31 to 34									
Bit	31	30	29	28	27	26	25	24	23	22	21	20	19	18	17	16	15	14	13	12	11	10	9	8	7	6	5	4	3	2	1	0
DW6	reserved																															
DW4	reserved																								J	NextPTDPointer[4:0]						
DW2	reserved		RL[3:0]			[1]	DataStartAddress[15:0]												reserved													
DW0	[2]	Mult [1:0]		MaxPacketLength[10:0]								NrBytesToTransfer[14:0] (32 kbytes for high-speed)												[1]	V							

[1] Reserved.

[2] EndPt[0].

Table 65: High-speed bulk IN and OUT, QHA: bit description

Bit	Symbol	Access	Description
DW7			
63 to 32	reserved	-	-
DW6			
31 to 0	reserved	-	-
DW5			
63 to 32	reserved	-	-
DW4			
31 to 6	reserved	-	0; not applicable for QHA.
5	J	SW — writes	Jump: 0 — To increment the PTD pointer 1 — To enable the next PTD branching.
4 to 0	NextPTDPointer [4:0]	SW — writes	Next PTD Counter: Next PTD branching assigned by the PTD pointer.
DW3			
63	A	SW — sets HW — resets	Active: Write the same value as that in V.
62	H	HW — writes	Halt: This bit correspond to the Halt bit of the Status field of QH.
61	B	HW — writes	Babble: This bit correspond to the Babble Detected bit in the Status field of the iTD, SiTD or QH. 1 — When babbling is detected, A and V are set to 0.
60	X	HW — writes	Error: This bit corresponds to the Transaction Error bit in the Status field of iTD, SiTD or QH (Exec_Trans, the signal name is xacterr). 0 — No PID error. 1 — If there are PID errors, this bit is set active. The A and V bits are also set to inactive. This transaction is retried three times.
59	reserved	-	-
58	P	HW — writes	Ping: For high-speed transactions, this bit corresponds to the Ping state bit in the Status field of a QH. 0 — Ping is not set. 1 — Ping is set. Software sets this bit to 0.
57	DT	HW — updates SW — writes	Data Toggle: This bit is filled by software to start a PTD. If NrBytesToTransfer[14:0] is not complete, software needs to read this value and then write back the same value to continue.
56 to 55	Cerr[1:0]	HW — writes SW — writes	Error Counter. This field corresponds to the Cerr[1:0] field in QH. The default value of this field is zero for isochronous transactions. 00 — The transaction will not retry. 11 — The transaction will retry three times. Hardware will decrement these values. When the transaction has tried three times, X error will be updated.
54 to 51	NakCnt[3:0]	HW — writes SW — writes	NAK Counter. This field corresponds to the NAKCnt field in QH. Software writes for the initial PTD launch. The V bit is reset if NakCnt decrements to zero and RL is a non-zero value. It reloads from RL if transaction is ACKed.
50 to 47	reserved	-	-

Table 65: High-speed bulk IN and OUT, QHA: bit description...continued

Bit	Symbol	Access	Description
46 to 32	NrBytesTransferred [14:0]	HW — writes SW — writes 0000	Number of Bytes Transferred: This field indicates the number of bytes sent or received for this transaction. If Mult[1:0] is greater than one, it is possible to store intermediate results in this field.
DW2			
31 to 29	reserved	-	Set to 0 for QHA.
28 to 25	RL[3:0]	SW — writes	Reload: If RL is set to 0h, hardware ignores the NakCnt value. RL and NakCnt are set to the same value before a transaction.
24	reserved	-	Always 0 for QHA.
23 to 8	DataStartAddress [15:0]	SW — writes	Data Start Address: This is the start address for the data that will be sent or received on or from the USB bus. This is the internal memory address and not the direct CPU address. RAM address = (CPU address – 400h)/8
7 to 0	reserved	-	-
DW1			
63 to 47	reserved	-	Always 0 for QHA.
46	S	SW — writes	This bit indicates whether a split transaction has to be executed: 0 — High-speed transaction 1 — Split transaction.
45 to 44	EPTYPE[1:0]	SW — writes	Transaction type: 00 — Control 10 — Bulk.
43 to 42	Token[1:0]	SW — writes	Token: Identifies the token Packet Identifier (PID) for this transaction: 00 — OUT 01 — IN 10 — SETUP 11 — PING (written by hardware only).
41 to 35	DeviceAddress[6:0]	SW — writes	Device Address: This is the USB address of the function containing the endpoint that is referred to by this buffer.
34 to 32	EndPt[3:1]	SW — writes	Endpoint: This is the USB address of the endpoint within the function.
DW0			
31	EndPt[0]	SW — writes	Endpoint: This is the USB address of the endpoint within the function.
30 to 29	Mult[1:0]	SW — writes	Multiplier: This field is a multiplier used by the Host Controller as the number of successive packets the Host Controller may submit to the endpoint in the current execution. For QHA, this is a copy of the Async Schedule Park mode count, if the Async Schedule Park mode is enabled. These EHCI registers need to be set to reflect multiple cycles. Applicable for high-speed only. Set this field to 01b. You can also set it to 11b and 10b depending on your application. 00b is undefined.

Table 65: High-speed bulk IN and OUT, QHA: bit description...continued

Bit	Symbol	Access	Description
28 to 18	MaxPacketLength [10:0]	SW — writes	Maximum Packet Length: This field indicates the maximum number of bytes that can be sent to or received from an endpoint in a single data packet. The maximum packet size for a bulk transfer is 512 bytes. The maximum packet size for the isochronous transfer is also variable at any whole number.
17 to 3	NrBytesToTransfer [14:0]	SW — writes	Number of Bytes to Transfer: This field indicates the number of bytes that can be transferred by this data structure. It is used to indicate the depth of the DATA field (32 kbytes).
2 to 1	reserved	-	-
0	V	SW — sets HW — resets	Valid: 0 — This bit is deactivated when the entire PTD is executed—across μ SOF and SOF—or when a fatal error is encountered. 1 — Software updates to one when there is payload to be sent or received even across ms boundary. The current PTD is active.

9.2 High-speed isochronous IN and OUT, isochronous Transfer Descriptor (iTd) (patent-pending)

Table 66: High-speed isochronous IN and OUT, iTD: bit allocation

Bit	63	62	61	60	59	58	57	56	55	54	53	52	51	50	49	48	47	46	45	44	43	42	41	40	39	38	37	36	35	34	33	32
DW7	ISOIN_7[11:0]											ISOIN_6[11:0]											ISOIN_5[7:0]									
DW5	ISOIN_2[7:0]							ISOIN_1[11:0]														ISOIN_0[11:0]										
DW3	A	H	B	reserved											NrBytesTransferred[14:0] (32 kbytes for high-speed)																	
DW1	reserved													S	EP Type [1:0]	Token [1:0]	DeviceAddress[6:0]							EndPt[3:0] 34 to 31								
Bit	31	30	29	28	27	26	25	24	23	22	21	20	19	18	17	16	15	14	13	12	11	10	9	8	7	6	5	4	3	2	1	0
DW6	ISOIN_5[3:0]			ISOIN_4[11:0]														ISOIN_3[11:0]											ISOIN_2[3:0]			
DW4	Status7[2:0]		Status6[2:0]		Status5[2:0]		Status4[2:0]		Status3[2:0]		Status2[2:0]		Status1[2:0]		Status0[2:0]		μSA[7:0]															
DW2	reserved								DataStartAddress[15:0]														μFrame[7:0]									
DW0	[2]	Mult [1:0]		MaxPacketLength[10:0]										NrBytesToTransfer[14:0] (32 kbytes for high-speed)														[1]	V			

[1] Reserved.

[2] EndPt[0].

Table 67: High-speed isochronous IN and OUT, iTD: bit description

Bit	Symbol	Access	Description
DW7			
63 to 52	ISOIN_7[11:0]	HW — writes	Bytes received during μ SOF7, if μ SA[7] is set to 1 and frame number is correct.
51 to 40	ISOIN_6[11:0]	HW — writes	Bytes received during μ SOF6, if μ SA[6] is set to 1 and frame number is correct.
39 to 32	ISOIN_5[7:0]	HW — writes	Bytes received during μ SOF5 (bits 11 to 4), if μ SA[5] is set to 1 and frame number is correct.
DW6			
31 to 28	ISOIN_5[3:0]	HW — writes	Bytes received during μ SOF5 (bits 3 to 0), if μ SA[5] is set to 1 and frame number is correct.
27 to 16	ISOIN_4[11:0]	HW — writes	Bytes received during μ SOF4, if μ SA[4] is set to 1 and frame number is correct.
15 to 4	ISOIN_3[11:0]	HW — writes	Bytes received during μ SOF3, if μ SA[3] is set to 1 and frame number is correct.
3 to 0	ISOIN_2[3:0]	HW — writes	Bytes received during μ SOF2 (bits 11 to 8), if μ SA[2] is set to 1 and frame number is correct.
DW5			
63 to 56	ISOIN_2[7:0]	HW — writes	Bytes received during μ SOF2 (bits 7 to 0), if μ SA[2] is set to 1 and frame number is correct.
55 to 44	ISOIN_1[11:0]	HW — writes	Bytes received during μ SOF1, if μ SA[1] is set to 1 and frame number is correct.
43 to 32	ISOIN_0[11:0]	HW — writes	Bytes received during μ SOF0, if μ SA[0] is set to 1 and frame number is correct.
DW4			
31 to 29	Status7[2:0]	HW — writes	ISO IN or OUT status at μ SOF7
28 to 26	Status6[2:0]	HW — writes	ISO IN or OUT status at μ SOF6
25 to 23	Status5[2:0]	HW — writes	ISO IN or OUT status at μ SOF5
22 to 20	Status4[2:0]	HW — writes	ISO IN or OUT status at μ SOF4
19 to 17	Status3[2:0]	HW — writes	ISO IN or OUT status at μ SOF3
16 to 14	Status2[2:0]	HW — writes	ISO IN or OUT status at μ SOF2
13 to 11	Status1[2:0]	HW — writes	ISO IN or OUT status at μ SOF1
10 to 8	Status0[2:0]	HW — writes	Status of the payload on the USB bus for this μ SOF after ISO has been delivered. Bit 0 — Transaction Error (IN and OUT) Bit 1 — Babble (IN token only) Bit 2 — underrun (OUT token only).
7 to 0	μ SA[7:0]	SW — writes (0 => 1) HW — writes (1 => 0) After processing	μSOF Active: When the frame number of bits DW1[7:3] match the frame number of USB bus, these bits are checked for 1 before they are sent for μ SOF. For example: If μ SA[7:0] = 1, 1, 1, 1, 1, 1, 1, 1: send ISO every μ SOF of the entire ms. If μ SA[7:0] = 0, 1, 0, 1, 0, 1, 0, 1: send ISO only on μ SOF0, μ SOF2, μ SOF4 and μ SOF6.
DW3			
63	A	SW — sets	Active: This bit is the same as the Valid bit.
62	H	HW — writes	Halt: Only one bit for the entire ms. When this bit is set, the Valid bit is reset. The device decides to stall an endpoint.

Table 67: High-speed isochronous IN and OUT, iTD: bit description...continued

Bit	Symbol	Access	Description
61	B	HW — writes	Babble: Not applicable here.
60 to 47	reserved	-	Set to 0 for isochronous.
46 to 32	NrBytesTransferred [14:0]	HW — writes	Number of Bytes Transferred: This field indicates the number of bytes sent or received for this transaction. If Mult[1:0] is greater than one, it is possible to store intermediate results in this field. NrBytesTransferred[14:0] is 32 kbytes per PTD.
DW2			
31 to 24	reserved	-	Set to 0 for isochronous.
23 to 8	DataStartAddress [15:0]	SW — writes	Data Start Address: This is the start address for the data that will be sent or received on or from the USB bus. This is the internal memory address and not the direct CPU address. RAM address = (CPU address – 400h)/8
7 to 0	μFrame[7:0]	SW — writes	Bits 2 to 0 — Don't care Bits 7 to 3 — Frame number that this PTD will be sent for ISO OUT or IN.
DW1			
63 to 47	reserved	-	-
46	S	SW — writes	This bit indicates whether a split transaction has to be executed. 0 — High-speed transaction 1 — Split transaction.
45 to 44	EPTYPE[1:0]	SW — writes	Endpoint type: 01 — Isochronous.
43 to 42	Token[1:0]	SW — writes	Token: This field indicates the token PID for this transaction: 00 — OUT 01 — IN.
41 to 35	DeviceAddress[6:0]	SW — writes	Device Address: This is the USB address of the function containing the endpoint that is referred to by this buffer.
34 to 32	EndPt[3:1]	SW — writes	Endpoint: This is the USB address of the endpoint within the function.
DW0			
31	EndPt[0]	SW — writes	Endpoint: This is the USB address of the endpoint within the function.
30 to 29	Mult[1:0]	SW — writes	This field is a multiplier counter used by the Host Controller as the number of successive packets the Host Controller may submit to the endpoint in the current execution. For isochronous OUT and IN: If Mult[1:0] is 01 — Data Toggle is Data0 If Mult[1:0] is 10 — Data Toggle is Data1 If Mult[1:0] is 11 — Data Toggle is Data2, and so on. For details, refer to <i>Enhanced Host Controller Interface Specification for Universal Serial Bus Rev. 1.0 Appendix D</i> .
28 to 18	MaxPacketLength [10:0]	SW — writes	Maximum Packet Length: This field indicates the maximum number of bytes that can be sent to or received from the endpoint in a single data packet. The maximum packet size for an isochronous transfer is 1024 bytes. The maximum packet size for the isochronous transfer is also variable at any whole number.

Table 67: High-speed isochronous IN and OUT, iTD: bit description...continued

Bit	Symbol	Access	Description
17 to 3	NrBytesToTransfer [14:0]	SW — writes	Number of Bytes Transferred: This field indicates the number of bytes that can be transferred by this data structure. It is used to indicate the depth of the DATA field (32 kbytes).
2 to 1	reserved	-	-
0	V	HW — resets SW — sets	0 — This bit is deactivated when the entire PTD is executed—across μ SOF and SOF—or when a fatal error is encountered. 1 — Software updates to one when there is payload to be sent or received even across ms boundary. The current PTD is active.

9.3 High-speed interrupt IN and OUT, Queue Head Periodic (QHP) (patent-pending)

Table 68: High-speed interrupt IN and OUT, QHP: bit allocation

Bit	63	62	61	60	59	58	57	56	55	54	53	52	51	50	49	48	47	46	45	44	43	42	41	40	39	38	37	36	35	34	33	32
DW7	INT_IN_7[11:0]											INT_IN_6[11:0]											INT_IN_5[7:0]									
DW5	INT_IN_2[7:0]							INT_IN_1[11:0]											INT_IN_0[11:0]													
DW3	A	H	reserved				D T	Cerr [1:0]	reserved							NrBytesTransferred[14:0] (32 kbytes for high-speed)																
DW1	reserved													S	EP Type [1:0]	Token [1:0]	DeviceAddress[6:0]				EndPt[3:0] 31 to 34											
Bit	31	30	29	28	27	26	25	24	23	22	21	20	19	18	17	16	15	14	13	12	11	10	9	8	7	6	5	4	3	2	1	0
DW6	INT_IN_5[3:0]			INT_IN_4[11:0]											INT_IN_3[11:0]											INT_IN_2[3:0]						
DW4	Status7[2:0]		Status6[2:0]		Status5[2:0]		Status4[2:0]		Status3[2:0]		Status2[2:0]		Status1[2:0]		Status0[2:0]		μSA[7:0]															
DW2	reserved							DataStartAddress[15:0]											μFrame[7:0]													
DW0	[2]	Mult [1:0]		MaxPacketLength[10:0]											NrBytesToTransfer[14:0] (32 kbytes for high-speed)											[1]	V					

[1] Reserved.

[2] EndPt[0].

Table 69: High-speed interrupt IN and OUT, QHP: bit description

Bit	Symbol	Access	Description
DW7			
63 to 52	INT_IN_7[[11:0]	HW — writes	Bytes received during μ SOF7, if μ SA[7] is set to 1 and frame number is correct.
51 to 40	INT_IN_6[11:0]	HW — writes	Bytes received during μ SOF6, if μ SA[6] is set to 1 and frame number is correct.
39 to 32	INT_IN_5[7:0]	HW — writes	Bytes received during μ SOF5 (bits 7 to 0), if μ SA[5] is set to 1 and frame number is correct.
DW6			
31 to 28	INT_IN_5[3:0]	HW — writes	Bytes received during μ SOF5 (bits 3 to 0), if μ SA[5] is set to 1 and frame number is correct.
27 to 16	INT_IN_4[11:0]	HW — writes	Bytes received during μ SOF4, if μ SA[4] is set to 1 and frame number is correct.
15 to 4	INT_IN_3[11:0]	HW — writes	Bytes received during μ SOF3, if μ SA[3] is set to 1 and frame number is correct.
3 to 0	INT_IN_2[3:0]	HW — writes	Bytes received during μ SOF2 (bits 11 to 8), if μ SA[2] is set to 1 and frame number is correct.
DW5			
63 to 56	INT_IN_2[7:0]	HW — writes	Bytes received during μ SOF2 (bits 7 to 0), if μ SA[2] is set to 1 and frame number is correct.
55 to 44	INT_IN_1[11:0]	HW — writes	Bytes received during μ SOF1, if μ SA[1] is set to 1 and frame number is correct.
43 to 32	INT_IN_0[11:0]	HW — writes	Bytes received during μ SOF0, if μ SA[0] is set to 1 and frame number is correct.
DW4		INT OUT or IN	
31 to 29	Status7[2:0]	HW — writes	INT IN or OUT status of μ SOF7
28 to 26	Status6[2:0]	HW — writes	INT IN or OUT status of μ SOF6
25 to 23	Status5[2:0]	HW — writes	INT IN or OUT status of μ SOF5
22 to 20	Status4[2:0]	HW — writes	INT IN or OUT status of μ SOF4
19 to 17	Status3[2:0]	HW — writes	INT IN or OUT status of μ SOF3
16 to 14	Status2[2:0]	HW — writes	INT IN or OUT status of μ SOF2
13 to 11	Status1[2:0]	HW — writes	INT IN or OUT status of μ SOF1
10 to 8	Status0[2:0]	HW — writes	Status of the payload on the USB bus for this μ SOF after INT has been delivered. Bit 0 — Transaction Error (IN and OUT) Bit 1 — Babble (IN token only) Bit 2 — underrun (OUT token only).
7 to 0	μ SA[7:0]	SW — writes (0 => 1) HW — writes (1 => 0) After processing	When the frame number of bits DW1[7:3] match the frame number of the USB bus, these bits are checked for 1 before they are sent for μ SOF. For example: When μ SA[7:0] = 1, 1, 1, 1, 1, 1, 1, 1: send INT for every μ SOF of the entire ms. When μ SA[7:0] = 0, 1, 0, 1, 0, 1, 0, 1: send INT for μ SOF0, μ SOF2, μ SOF4 and μ SOF6. When μ SA[7:0] = 1, 0, 0, 0, 1, 0, 0, 0 = send INT for every fourth μ SOF.
DW3			
63	A	HW — writes SW — writes	Active: Write the same value as that in V.

Table 69: High-speed interrupt IN and OUT, QHP: bit description...continued

Bit	Symbol	Access	Description																																								
62	H	HW — writes	Halt: Transaction is halted.																																								
61 to 58	reserved	-	-																																								
57	DT	HW — writes SW — writes	Data Toggle: Set the Data Toggle bit to start the PTD. Software writes the current transaction toggle value. Hardware writes the next transaction toggle value.																																								
56 to 55	Cerr[1:0]	HW — writes SW — writes	Error Counter. This field corresponds to the Cerr[1:0] field in the QH. The default value of this field is zero for isochronous transactions.																																								
54 to 47	reserved	-	-																																								
46 to 32	NrBytes Transferred [14:0]	HW — writes	Number of Bytes Transferred: This field indicates the number of bytes sent or received for this transaction. If Mult[1:0] is greater than one, it is possible to store intermediate results in this field.																																								
DW2																																											
31 to 24	reserved	-	-																																								
23 to 8	DataStart Address [15:0]	SW — writes	Data Start Address: This is the start address for the data that will be sent or received on or from the USB bus. This is the internal memory address and not the direct CPU address. RAM address = (CPU address – 400h)/8																																								
7 to 0	μFrame[7:0]	SW — writes	Bits 7 to 3 represent the polling rate for ms-based polling. The INT polling rate is defined as $2^{(b-1)} \mu\text{SOF}$, where b is 1 to 9. When b is 1, 2, 3 or 4, use μSA to define polling because the rate is equal to or less than 1 ms. Bits 7 to 3 are set to 0. Polling checks μSA bits for μSOF rates.																																								
			<table border="1"> <thead> <tr> <th>b</th> <th>rate</th> <th>μFrame[7:3]</th> <th>μSA[7:0]</th> </tr> </thead> <tbody> <tr> <td>1</td> <td>1 μSOF</td> <td>0</td> <td>11111111</td> </tr> <tr> <td>2</td> <td>2 μSOF</td> <td>0</td> <td>10101010 or 01010101</td> </tr> <tr> <td>3</td> <td>4 μSOF</td> <td>0</td> <td>any 2 bits set</td> </tr> <tr> <td>4</td> <td>1 ms</td> <td>0</td> <td>any 1 bit set</td> </tr> <tr> <td>5</td> <td>2 ms</td> <td>1</td> <td>any 1 bit set</td> </tr> <tr> <td>6</td> <td>4 ms</td> <td>10 to 11</td> <td>any 1 bit set</td> </tr> <tr> <td>7</td> <td>8 ms</td> <td>100 to 111</td> <td>any 1 bit set</td> </tr> <tr> <td>8</td> <td>16 ms</td> <td>1000 to 1111</td> <td>any 1 bit set</td> </tr> <tr> <td>9</td> <td>32 ms</td> <td>10000 to 11111</td> <td>any 1 bit set</td> </tr> </tbody> </table>	b	rate	μFrame[7:3]	μSA[7:0]	1	1 μSOF	0	11111111	2	2 μSOF	0	10101010 or 01010101	3	4 μSOF	0	any 2 bits set	4	1 ms	0	any 1 bit set	5	2 ms	1	any 1 bit set	6	4 ms	10 to 11	any 1 bit set	7	8 ms	100 to 111	any 1 bit set	8	16 ms	1000 to 1111	any 1 bit set	9	32 ms	10000 to 11111	any 1 bit set
b	rate	μFrame[7:3]	μSA[7:0]																																								
1	1 μSOF	0	11111111																																								
2	2 μSOF	0	10101010 or 01010101																																								
3	4 μSOF	0	any 2 bits set																																								
4	1 ms	0	any 1 bit set																																								
5	2 ms	1	any 1 bit set																																								
6	4 ms	10 to 11	any 1 bit set																																								
7	8 ms	100 to 111	any 1 bit set																																								
8	16 ms	1000 to 1111	any 1 bit set																																								
9	32 ms	10000 to 11111	any 1 bit set																																								
DW1																																											
63 to 47	reserved	-	-																																								
46	S	SW — writes	This bit indicates if a split transaction has to be executed: 0 — High-speed transaction 1 — Split transaction.																																								
45 to 44	EPTType[1:0]	SW — writes	Endpoint type: 11 — Interrupt.																																								
43 to 42	Token[1:0]	SW — writes	Token: This field indicates the token PID for this transaction: 00 — OUT 01 — IN.																																								

Table 69: High-speed interrupt IN and OUT, QHP: bit description...continued

Bit	Symbol	Access	Description
41 to 35	DeviceAddress [6:0]	SW — writes	Device Address: This is the USB address of the function containing the endpoint that is referred to by the buffer.
34 to 32	EndPt[3:1]	SW — writes	Endpoint: This is the USB address of the endpoint within the function.
DW0			
31	EndPt[0]	SW — writes	Endpoint: This is the USB address of the endpoint within the function.
30 to 29	Mult[1:0]	SW — writes	Multiplier: This field is a multiplier counter used by the Host Controller as the number of successive packets the Host Controller may submit to the endpoint in the current execution. Set this field to 01b. You can also set it to 11b and 10b depending on your application. 00b is undefined.
28 to 18	MaxPacket Length[10:0]	SW — writes	Maximum Packet Length: This field indicates the maximum number of bytes that can be sent to or received from the endpoint in a single data packet.
17 to 3	NrBytesTo Transfer[14:0]	SW — writes	Number of Bytes to Transfer: This field indicates the number of bytes can be transferred by this data structure. It is used to indicate the depth of the DATA field (32 kbytes).
2 to 1	reserved	-	-
0	V	SW — sets HW — resets	Valid: 0 — This bit is deactivated when the entire PTD is executed—across μ SOF and SOF—or when a fatal error is encountered. 1 — Software updates to one when there is payload to be sent or received even across ms boundary. The current PTD is active.

9.4 Start and complete split for bulk, Queue Head Asynchronous Start Split and Start Complete (QHA-SS/SC) (patent-pending)

Table 70: Start and complete split for bulk, QHASS/SC: bit allocation

Bit	63	62	61	60	59	58	57	56	55	54	53	52	51	50	49	48	47	46	45	44	43	42	41	40	39	38	37	36	35	34	33	32
DW7	reserved																															
DW5	reserved																															
DW3	A	H	B	X	S C	[1]	D T	Cerr [1:0]	NakCnt[3:0]			reserved			NrBytesTransferred[14:0]																	
DW1	HubAddress[6:0]						PortNumber[6:0]						SE[1:0]	[1]	S	EP Type [1:0]	Token [1:0]	DeviceAddress[6:0]						EndPt[3:0] (31 to 34)								
Bit	31	30	29	28	27	26	25	24	23	22	21	20	19	18	17	16	15	14	13	12	11	10	9	8	7	6	5	4	3	2	1	0
DW6	reserved																															
DW4	reserved																								J	NextPTDAddress[4:0]						
DW2	reserved		RL[3:0]			[1]	DataStartAddress[15:0]														reserved											
DW0	[2]	[1]	MaxPacketLength[10:0]										NrBytesToTransfer[14:0] (32 kbytes for high-speed)														[1]	V				

[1] Reserved.

[2] EndPt[0].

Table 71: Start and complete split for bulk, QHASS/SC: bit description

Bit	Symbol	Access	Description
DW7			
63 to 32	reserved	-	-
DW6			
31 to 0	reserved	-	-
DW5			
63 to 32	reserved	-	-
DW4			
31 to 6	reserved	-	-
5	J	SW — writes	0 — To increment the PTD pointer 1 — To enable the next PTD branching.
4 to 0	NextPTDPointer [1:0]	SW — writes	Next PTD branching assigned by the PTD pointer.
DW3			
63	A	SW — sets HW — resets	Active: Write the same value as that in V.
62	H	HW — writes	Halt: This bit correspond to the Halt bit of the Status field of QH.
61	B	HW — writes	Babble: This bit correspond to the Babble Detected bit in the Status field of the iTD, SiTD or QH. 1 — when babbling is detected, A and V are set to 0.
60	X		Transaction Error: This bit corresponds to the Transaction Error bit in the status field.
59	SC	SW — writes 0 HW — updates	Start/Complete: 0 — Start split 1 — Complete split.
58	reserved	-	-
57	DT	HW — writes SW — writes	Data Toggle: Set the Data Toggle bit to start for the PTD.
56 to 55	Cerr[1:0]	HW — updates SW — writes	Error Counter: This field contains the error count for start and complete split (QHASS). When an error has no response or bad response, Cerr[1:0] will be decremented to zero and then Valid will be set to zero. A NAK or NYET will reset Cerr[1:0]. For details, refer to <i>Enhanced Host Controller Interface Specification for Universal Serial Bus Rev. 1.0 Section 4.12.1.2</i> . If retry has insufficient time at the beginning of a new SOF, the first PTD must be this retry. This can be accomplished by if aperiodic PTD is not advanced.
54 to 51	NakCnt[3:0]	HW — writes SW — writes	NAK Counter. The V bit is reset if NakCnt decrements to zero and RL is a non-zero value. Not applicable to isochronous split transactions.
50 to 47	reserved	-	-
46 to 32	NrBytesTransferred [14:0]	HW — writes	Number of Bytes Transferred: This field indicates the number of bytes sent or received for this transaction.
DW2			
31 to 29	reserved	-	-

Table 71: Start and complete split for bulk, QHASS/SC: bit description...continued

Bit	Symbol	Access	Description															
28 to 25	RL[3:0]	SW — writes	Reload. If RL is set to 0h, hardware ignores the NakCnt value. Set RL and NakCnt to the same value before a transaction. For full-speed and low-speed transactions, set this field to 0000b. Not applicable to isochronous start split and complete split.															
24	reserved	-	-															
23 to 8	DataStartAddress [15:0]	SW — writes	Data Start Address: This is the start address for the data that will be sent or received on or from the USB bus. This is the internal memory address and not the direct CPU address. RAM address = (CPU address – 400h)/8															
7 to 0	reserved	-	-															
DW1																		
63 to 57	HubAddress[6:0]	SW — writes	Hub Address: This indicates the hub address. Zero for the internal or embedded hub.															
56 to 50	PortNumber[6:0]	SW — writes	Port Number: This indicates the port number of the hub or embedded TT.															
49 to 48	SE[1:0]	SW — writes	This depends on the endpoint type and direction. It is valid only for split transactions. The following applies to start split and complete split only. <table border="1"> <thead> <tr> <th>Bulk</th> <th>Control</th> <th>S</th> <th>E</th> <th>Remarks</th> </tr> </thead> <tbody> <tr> <td>I/O</td> <td>I/O</td> <td>1</td> <td>0</td> <td>low-speed</td> </tr> <tr> <td>I/O</td> <td>I/O</td> <td>0</td> <td>0</td> <td>full-speed</td> </tr> </tbody> </table>	Bulk	Control	S	E	Remarks	I/O	I/O	1	0	low-speed	I/O	I/O	0	0	full-speed
Bulk	Control	S	E	Remarks														
I/O	I/O	1	0	low-speed														
I/O	I/O	0	0	full-speed														
47	reserved	-	-															
46	S	SW — writes	This bit indicates whether a split transaction has to be executed: 0 — High-speed transaction 1 — Split transaction.															
45 to 44	EPTYPE[1:0]	SW — writes	Endpoint Type: 00 — Control 10 — Bulk.															
43 to 42	Token[1:0]	SW — writes	Token: This field indicates the PID for this transaction. 00 — OUT 01 — IN 10 — SETUP.															
41 to 35	DeviceAddress [6:0]	SW — writes	Device Address: This is the USB address of the function containing the endpoint that is referred to by this buffer.															
34 to 32	EndPt[3:1]	SW — writes	Endpoint: This is the USB address of the endpoint within the function.															
DW0																		
31	EndPt[0]	SW — writes	Endpoint: This is the USB address of the endpoint within the function.															
30 to 29	reserved	-	-															
28 to 18	MaximumPacket Length[10:0]	SW — writes	Maximum Packet Length: This field indicates the maximum number of bytes that can be sent to or received from an endpoint in a single data packet. The maximum packet size for full-speed is 64 bytes as defined in the <i>Universal Serial Bus Specification Rev. 2.0</i> .															

Table 71: Start and complete split for bulk, QHASS/SC: bit description...continued

Bit	Symbol	Access	Description
17 to 3	NrBytesToTransfer [14:0]	SW — writes	Number of Bytes to Transfer: This field indicates the number of bytes that can be transferred by this data structure. It is used to indicate the depth of the DATA field.
2 to 1	reserved	-	-
0	V	SW — sets HW — resets	Valid: 0 — This bit is deactivated when the entire PTD is executed—across μ SOF and SOF—or when a fatal error is encountered. 1 — Software updates to one when there is payload to be sent or received even across ms boundary. The current PTD is active.

9.5 Start and complete split for isochronous, Split isochronous Transfer Descriptor (SiTD) (patent-pending)

Table 72: Start and complete split for isochronous, SiTD: bit allocation

Bit	63	62	61	60	59	58	57	56	55	54	53	52	51	50	49	48	47	46	45	44	43	42	41	40	39	38	37	36	35	34	33	32
DW7	reserved																								ISO_IN_7[7:0]							
DW5	ISO_IN_2[7:0]						ISO_IN_1[7:0]						ISO_IN_0[7:0]						μSCS[7:0] [2]													
DW3	A	H	B	X	S	[1]	D	reserved														NrBytesTransferred[11:0]										
DW1	HubAddress[6:0]						PortNumber[6:0]						reserved		S	EP Type [1:0]	Token [1:0]	DeviceAddress[6:0]				EndPt[3:0] (31 to 34)										
Bit	31	30	29	28	27	26	25	24	23	22	21	20	19	18	17	16	15	14	13	12	11	10	9	8	7	6	5	4	3	2	1	0
DW6	ISO_IN_6[7:0]						ISO_IN_5[7:0]						ISO_IN_4[7:0]						ISO_IN_3[7:0]													
DW4	Status7 [2:0]		Status6 [2:0]		Status5 [2:0]		Status4 [2:0]		Status3 [2:0]		Status2 [2:0]		Status1 [2:0]		Status0 [2:0]		μSA[7:0]															
DW2	reserved						DataStartAddress[15:0]										μFrame[7:0] (full-speed)															
DW0	[3]	[1]	TT_MPS_Len[10:0]						NrBytesToTransfer[14:0] (1 kbyte for full-speed)										[1]	V												

[1] Reserved.

[2] Note the change in the position of USCS[7:0] and NrBytesReceived_CS_IN.

[3] EndPt[0].

Table 73: Start and complete split for isochronous, SiTD: bit description

Bit	Symbol	Access	Description
DW7			
63 to 40	reserved	-	-
39 to 32	ISO_IN_7[7:0]	HW — writes	Bytes received during μ SOF7, if μ SA[7] is set to 1 and frame number is correct.
DW6			
31 to 24	ISO_IN_6[7:0]	HW — writes	Bytes received during μ SOF6, if μ SA[6] is set to 1 and frame number is correct.
23 to 16	ISO_IN_5[7:0]	HW — writes	Bytes received during μ SOF5, if μ SA[5] is set to 1 and frame number is correct.
15 to 8	ISO_IN_4[7:0]	HW — writes	Bytes received during μ SOF4, if μ SA[4] is set to 1 and frame number is correct.
7 to 0	ISO_IN_3[7:0]	HW — writes	Bytes received during μ SOF3, if μ SA[3] is set to 1 and frame number is correct.
DW5			
63 to 56	ISO_IN_2[7:0]	HW — writes	Bytes received during μ SOF2 (bits 7 to 0), if μ SA[2] is set to 1 and frame number is correct.
55 to 48	ISO_IN_1[7:0]	HW — writes	Bytes received during μ SOF1, if μ SA[1] is set to 1 and frame number is correct.
47 to 40	ISO_IN_0[7:0]	HW — writes	Bytes received during μ SOF0 if μ SA[0] is set to 1 and frame number is correct.
39 to 32	μ SCS[7:0]	SW — writes (0 \Rightarrow 1) HW — writes (1 \Rightarrow 0) After processing	All bits can be set to one for every transfer. It specifies which μ SOF the complete split needs to be sent. Valid only for IN. Start split (SS) and complete split (CS) active bits— μ SA = 0000 0001, μ S CS = 0000 0100—will cause SS to execute in μ Frame0 and CS in μ Frame2.
DW4			
31 to 29	Status7[2:0]	HW — writes	isochronous IN or OUT status of μ SOF7
28 to 26	Status6[2:0]	HW — writes	isochronous IN or OUT status of μ SOF6
25 to 23	Status5[2:0]	HW — writes	isochronous IN or OUT status of μ SOF5
22 to 20	Status4[2:0]	HW — writes	isochronous IN or OUT status of μ SOF4
19 to 17	Status3[2:0]	HW — writes	isochronous IN or OUT status of μ SOF3
16 to 14	Status2[2:0]	HW — writes	isochronous IN or OUT status of μ SOF2
13 to 11	Status1[2:0]	HW — writes	isochronous IN or OUT status of μ SOF1
10 to 8	Status0[2:0]	HW — writes	isochronous IN or OUT status of μ SOF0 Bit 0 — Transaction Error (IN and OUT) Bit 1 — Babble (IN token only) Bit 2 — underrun (OUT token only).
7 to 0	μ SA[7:0]	SW — writes (0 \Rightarrow 1) HW — writes (1 \Rightarrow 0) After processing	Specifies which μ SOF the start split needs to be placed. For OUT token: When the frame number of bits DW1(7-3) matches the frame number of the USB bus, these bits are checked for one before they are sent for the μ SOF. For IN token: Only μ SOF0, μ SOF1, μ SOF2 or μ SOF3 can be set to 1. Nothing can be set for μ SOF4 and above.

Table 73: Start and complete split for isochronous, SiTD: bit description...continued

Bit	Symbol	Access	Description
DW3			
63	A	SW — sets HW — resets	Active: Write the same value as that in V.
62	H	HW — writes	Halt: The Halt bit is set when any microframe transfer status has a stalled or halted condition.
61	B	HW — writes	Babble: This bit corresponds to bit 1 of Status0 to Status7 for every microframe transfer status.
60	X	HW — writes	Transaction Error: This bit corresponds to bit 0 of Status0 to Status7 for every microframe transfer status.
59	SC	SW — writes 0 HW — updates	Start/Complete: 0 — Start split 1 — Complete split.
58	reserved	-	-
57	DT	HW — writes SW — writes	Data Toggle: Set the Data Toggle bit to start for the PTD.
56 to 44	reserved	-	-
43 to 32	NrBytesTransferred [11:0]	HW — writes	Number of Bytes Transferred: This field indicates the number of bytes sent or received for this transaction.
DW2			
31 to 24	reserved	-	-
23 to 8	DataStartAddress [15:0]	SW — writes	Data Start Address: This is the start address for the data that will be sent or received on or from the USB bus. This is the internal memory address and not the CPU address.
7 to 0	μ Frame[7:0]	SW — writes	Bits 7 to 3 determine which frame to execute.
DW1			
63 to 57	HubAddress [6:0]	SW — writes	Hub Address: This indicates the hub address. Zero for the internal or embedded hub.
56 to 50	PortNumber [6:0]	SW — writes	Port Number: This indicates the port number of the hub or embedded TT.
49 to 47	reserved	-	-
46	S	SW — writes	This bit indicates whether a split transaction has to be executed: 0 — High-speed transaction 1 — Split transaction.
45 to 44	EPTYPE[1:0]	SW — writes	Transaction type: 01 — Isochronous.
43 to 42	Token[1:0]	SW — writes	Token PID for this transaction: 00 — OUT 01 — IN.
41 to 35	Device Address[6:0]	SW — writes	Device Address: This is the USB address of the function containing the endpoint that is referred to by this buffer.
34 to 32	EndPt[3:1]	SW — writes	Endpoint: This is the USB address of the endpoint within the function.
DW0			
31	EndPt[0]	SW — writes	Endpoint: This is the USB address of the endpoint within the function.
30 to 29	reserved	-	-

Table 73: Start and complete split for isochronous, SiTD: bit description...continued

Bit	Symbol	Access	Description
28 to 18	TT_MPS_Len [10:0]	SW — writes	Transaction Translator Maximum Packet Size Length: This field indicates the maximum number of bytes that can be sent per start split depending on the number of total bytes needed. If the total bytes to be sent for the entire ms is greater than 188 bytes, this field should be set to 188 bytes for an OUT token and 192 bytes for an IN token. Otherwise, this field should be equal to the total bytes sent.
17 to 3	NrBytesTo Transfer [14:0]	SW — writes	Number of Bytes to Transfer: This field indicates the number of bytes that can be transferred by this data structure. It is used to indicate the depth of the DATA field. This field is restricted to 1023 bytes because in SiTD the maximum allowable payload for a full-speed device is 1023 bytes. This field indirectly becomes the maximum packet size of the downstream device.
2 to 1	reserved	-	-
0	V	SW — sets HW — resets	0 — This bit is deactivated when the entire PTD is executed—across μ SOF and SOF—or when a fatal error is encountered. 1 — Software updates to one when there is payload to be sent or received even across ms boundary. The current PTD is active.

9.6 Start and complete split for interrupt (patent-pending)

Table 74: Start and complete split for interrupt: bit allocation

Bit	63	62	61	60	59	58	57	56	55	54	53	52	51	50	49	48	47	46	45	44	43	42	41	40	39	38	37	36	35	34	33	32
DW7	reserved																								INT_IN_7[7:0]							
DW5	INT_IN_2[7:0]						INT_IN_1[7:0]						INT_IN_0[7:0]						μSCS[7:0]													
DW3	A	H	B	X	S	[1]	D	Cerr	reserved											NrBytesTransferred[11:0] (4 kbytes for full-speed and low-speed)												
DW1	HubAddress[6:0]						PortNumber[6:0]						SE[1:0]	-	S	EP Type [1:0]	Token [1:0]	DeviceAddress[6:0]				EndPt [3:0]										
Bit	31	30	29	28	27	26	25	24	23	22	21	20	19	18	17	16	15	14	13	12	11	10	9	8	7	6	5	4	3	2	1	0
DW6	INT_IN_6[7:0]						INT_IN_5[7:0]						INT_IN_4[7:0]						INT_IN_3[7:0]													
DW4	Status7 [2:0]		Status6 [2:0]		Status5 [2:0]		Status4 [2:0]		Status3 [2:0]		Status2 [2:0]		Status1 [2:0]		Status0 [2:0]		μSA[7:0]															
DW2	reserved						DataStartAddress[15:0]											μFrame[7:0] (full-speed and low-speed)														
DW0	[2]	[1]	MaxPacketLength[10:0]						NrBytesToTransfer[14:0] (4 kbytes for full-speed and low-speed)											[1]	V											

[1] Reserved.

[2] EndPt[0].

Table 75: Start and complete split for interrupt: bit description

Bit	Symbol	Access	Description
DW7			
63 to 40	reserved	-	-
39 to 32	INT_IN_7[7:0]	HW — writes	Bytes received during μ SOF7, if μ SA[7] is set to 1 and frame number is correct. The new value continuously overwrites the old value.
DW6			
31 to 24	INT_IN_6[7:0]	HW — writes	Bytes received during μ SOF6, if μ SA[6] is set to 1 and frame number is correct. The new value continuously overwrites the old value.
23 to 16	INT_IN_5[7:0]	HW — writes	Bytes received during μ SOF5, if μ SA[5] is set to 1 and frame number is correct. The new value continuously overwrites the old value.
15 to 8	INT_IN_4[7:0]	HW — writes	Bytes received during μ SOF4, if μ SA[4] is set to 1 and frame number is correct. The new value continuously overwrites the old value.
7 to 0	INT_IN_3[7:0]	HW — writes	Bytes received during μ SOF3, if μ SA[3] is set to 1 and frame number is correct. The new value continuously overwrites the old value.
DW5			
63 to 56	INT_IN_2[7:0]	HW — writes	Bytes received during μ SOF2 (bits 7 to 0), if μ SA[2] is set to 1 and frame number is correct. The new value continuously overwrites the old value.
55 to 48	INT_IN_1[7:0]	HW — writes	Bytes received during μ SOF1, if μ SA[1] is set to 1 and frame number is correct. The new value continuously overwrites the old value.
47 to 40	INT_IN_0[7:0]	HW — writes	Bytes received during μ SOF0 if μ SA[0] is set to 1 and frame number is correct. The new value continuously overwrites the old value.
39 to 32	μ SCS[7:0]	SW — writes (0 => 1) HW — writes (1 => 0) After processing	All bits can be set to one for every transfer. It specifies which μ SOF the complete split needs to be sent. Valid only for IN. Start split (SS) and complete split (CS) active bits— μ SA = 0000 0001, μ S CS = 0000 0100—will cause SS to execute in μ Frame0 and CS in μ Frame2.
DW4			
31 to 29	Status7[2:0]	HW — writes	interrupt IN or OUT status of μ SOF7
28 to 26	Status6[2:0]	HW — writes	interrupt IN or OUT status of μ SOF6
25 to 23	Status5[2:0]	HW — writes	interrupt IN or OUT status of μ SOF5
22 to 20	Status4[2:0]	HW — writes	interrupt IN or OUT status of μ SOF4
19 to 17	Status3[2:0]	HW — writes	interrupt IN or OUT status of μ SOF3
16 to 14	Status2[2:0]	HW — writes	interrupt IN or OUT status of μ SOF2
13 to 11	Status1[2:0]	HW — writes	interrupt IN or OUT status of μ SOF1
10 to 8	Status0[2:0]	HW — writes	interrupt IN or OUT status of μ SOF0 Bit 0 — Transaction Error (IN and OUT) Bit 1 — Babble (IN token only) Bit 2 — underrun (OUT token only).
7 to 0	μ SA[7:0]	SW — writes (0 => 1) HW — writes (1 => 0) After processing	Specifies which μ SOF the start split needs to be placed. For OUT token: When the frame number of bits DW1(7-3) matches the frame number of the USB bus, these bits are checked for one before they are sent for the μ SOF. For IN token: Only μ SOF0, μ SOF1, μ SOF2 or μ SOF3 can be set to 1. Nothing can be set for μ SOF4 and above.

Table 75: Start and complete split for interrupt: bit description...continued

Bit	Symbol	Access	Description															
DW3																		
63	A	SW — sets HW — resets	Active: Write the same value as that in V.															
62	H	HW — writes	Halt: The Halt bit is set when any microframe transfer status has a stalled or halted condition.															
61	B	HW — writes	Babble: This bit corresponds to bit 1 of Status0 to Status7 for every microframe transfer status.															
60	X	HW — writes	Transaction Error: This bit corresponds to bit 0 of Status0 to Status7 for every microframe transfer status.															
59	SC	SW — writes 0 HW — updates	Start/Complete: 0 — Start split 1 — Complete split.															
58	reserved	-	-															
57	DT	HW — writes SW — writes	Data Toggle: For an interrupt transfer, set correct bit to start the PTD.															
56 to 55	Cerr[1:0]	HW — writes SW — writes	Error Counter. This field corresponds to the Cerr[1:0] field in QH. 00 — The transaction will not retry. 11 — The transaction will retry three times. Hardware will decrement these values. When the transaction has tried three times, X error will be updated.															
54 to 44	reserved	-	-															
43 to 32	NrBytes Transferred [11:0]	HW — writes	Number of Bytes Transferred: This field indicates the number of bytes sent or received for this transaction.															
DW2																		
31 to 24	reserved	-	-															
23 to 8	DataStart Address[15:0]	SW — writes	Data Start Address: This is the start address for the data that will be sent or received on or from the USB bus. This is the internal memory address and not the CPU address.															
7 to 0	μ Frame[7:0]	SW — writes	Bits 7 to 3 is the ms polling rate. Polling rate is defined as $2^{(b-1)} \mu\text{SOF}$; where $b = 4$ to 16. When b is 4, every ms is executed.															
			<table border="1"> <thead> <tr> <th>b</th> <th>Rate</th> <th>Bits 7 to 3</th> </tr> </thead> <tbody> <tr> <td>4</td> <td>2</td> <td>00001</td> </tr> <tr> <td>5</td> <td>4</td> <td>00010 or 00011</td> </tr> <tr> <td>6</td> <td>8</td> <td>00100 or 00101</td> </tr> <tr> <td>7</td> <td>16</td> <td>01000 or 01001 up to 32 ms</td> </tr> </tbody> </table>	b	Rate	Bits 7 to 3	4	2	00001	5	4	00010 or 00011	6	8	00100 or 00101	7	16	01000 or 01001 up to 32 ms
b	Rate	Bits 7 to 3																
4	2	00001																
5	4	00010 or 00011																
6	8	00100 or 00101																
7	16	01000 or 01001 up to 32 ms																
DW1																		
63 to 57	HubAddress [6:0]	SW — writes	Hub Address: This indicates the hub address. Zero for the internal or embedded hub.															
56 to 50	PortNumber [6:0]	SW — writes	Port Number: This indicates the port number of the hub or embedded TT.															

Table 75: Start and complete split for interrupt: bit description...continued

Bit	Symbol	Access	Description												
49 to 48	SE[1:0]	SW — writes	This depends on the endpoint type and direction. It is valid only for split transactions. The following applies to start split and complete split only. <table border="1"> <thead> <tr> <th>Interrupt</th> <th>S</th> <th>E</th> <th>Remarks</th> </tr> </thead> <tbody> <tr> <td>I/O</td> <td>1</td> <td>0</td> <td>low-speed</td> </tr> <tr> <td>I/O</td> <td>0</td> <td>0</td> <td>full-speed</td> </tr> </tbody> </table>	Interrupt	S	E	Remarks	I/O	1	0	low-speed	I/O	0	0	full-speed
Interrupt	S	E	Remarks												
I/O	1	0	low-speed												
I/O	0	0	full-speed												
47	reserved	-	-												
46	S	SW — writes	This bit indicates whether a split transaction has to be executed: 0 — High-speed transaction 1 — Split transaction.												
45 to 44	EPTYPE[1:0]	SW — writes	Transaction type: 11 — Interrupt.												
43 to 42	Token[1:0]	SW — writes	Token PID for this transaction: 00 — OUT 01 — IN.												
41 to 35	DeviceAddress [6:0]	SW — writes	Device Address: This is the USB address of the function containing the endpoint that is referred to by this buffer.												
34 to 32	EndPt[3:1]	SW — writes	Endpoint: This is the USB address of the endpoint within the function.												
DW0															
31	EndPt[0]	SW — writes	Endpoint: This is the USB address of the endpoint within the function.												
30 to 29	reserved	-	-												
28 to 18	MaxPacket Length[10:0]	SW — writes	Maximum Packet Length: This field indicates the maximum number of bytes that can be sent to or received from an endpoint in a single data packet. The maximum packet size for the full-speed and low-speed devices is 64 bytes as defined in the <i>Universal Serial Bus Specification Rev. 2.0</i> .												
17 to 3	NrBytesTo Transfer[14:0]	SW — writes	Number of Bytes to Transfer: This field indicates the number of bytes that can be transferred by this data structure. It is used to indicate the depth of the DATA field. The maximum total number of bytes for this transaction is 4 kbytes.												
2 to 1	reserved	-	-												
0	V	SW — sets HW — resets	0 — This bit is deactivated when the entire PTD is executed—across μ SOF and SOF—or when a fatal error is encountered. 1 — Software updates to one when there is payload to be sent or received even across ms boundary. The current PTD is active.												

10. Power consumption

Table 76: Power consumption

Number of ports working	I_{CC}	$I_{CC(I/O)}$
One port working (high-speed)		
$V_{CC} = 5.0\text{ V}, V_{CC(I/O)} = 3.3\text{ V}$	90 mA	<10 μA
$V_{CC} = 3.3\text{ V}, V_{CC(I/O)} = 3.3\text{ V}$	77 mA	<10 μA
$V_{CC} = 5.0\text{ V}, V_{CC(I/O)} = 1.8\text{ V}$	82 mA	<10 μA
$V_{CC} = 3.3\text{ V}, V_{CC(I/O)} = 1.8\text{ V}$	77 mA	<10 μA
Two ports working (high-speed)		
$V_{CC} = 5.0\text{ V}, V_{CC(I/O)} = 3.3\text{ V}$	110 mA	<10 μA
$V_{CC} = 3.3\text{ V}, V_{CC(I/O)} = 3.3\text{ V}$	97 mA	<10 μA
$V_{CC} = 5.0\text{ V}, V_{CC(I/O)} = 1.8\text{ V}$	102 mA	<10 μA
$V_{CC} = 3.3\text{ V}, V_{CC(I/O)} = 1.8\text{ V}$	97 mA	<10 μA
Three ports working (high-speed)		
$V_{CC} = 5.0\text{ V}, V_{CC(I/O)} = 3.3\text{ V}$	130 mA	<10 μA
$V_{CC} = 3.3\text{ V}, V_{CC(I/O)} = 3.3\text{ V}$	117 mA	<10 μA
$V_{CC} = 5.0\text{ V}, V_{CC(I/O)} = 1.8\text{ V}$	122 mA	<10 μA
$V_{CC} = 3.3\text{ V}, V_{CC(I/O)} = 1.8\text{ V}$	117 mA	<10 μA

Remark: The idle operating current, that is, when the ISP1760 is in operational mode—initialized and without any devices connected, is 70 mA. The additional current consumption on I_{CC} is below 1 mA per port in the case of full-speed and low-speed devices.

Remark: Deep-sleep suspend mode ensures the lowest power consumption when V_{CC} is always supplied to the ISP1760. In this case, the suspend current is typically about 100 μA at room temperature. The suspend current may increase if the ambient temperature increases. For details, see [Section 7.6](#).

Remark: In hybrid mode, when V_{CC} is disconnected $I_{CC(I/O)}$ will be generally below 100 μA . The average value is 60 μA to 70 μA .

11. Limiting values

Table 77: Absolute maximum ratings

In accordance with the Absolute Maximum Rating System (IEC 60134).

Symbol	Parameter	Conditions	Min	Max	Unit
$V_{CC(I/O)}$	supply voltage		-0.5	+3.6	V
$V_{CC(5V0)}$	supply voltage		-0.5	+5.5	V
I_{lu}	latch-up current	$V_I < 0$ or $V_I > V_{CC}$	-	100	mA
V_{esd}	electrostatic discharge voltage	$I_{LI} < 1 \mu A$	-4000	+4000	V
T_{stg}	storage temperature		-40	+125	°C

12. Recommended operating conditions

Table 78: Recommended operating conditions

Symbol	Parameter	Conditions	Min	Typ	Max	Unit
$V_{CC(I/O)}$	supply voltage	$V_{CC(I/O)} = 3.3 V$	3.0	3.3	3.6	V
		$V_{CC(I/O)} = 1.8 V$	1.65	1.8	1.95	V
$V_{CC(5V0)}$	supply voltage		3.0	-	5.5	V
T_{amb}	operating temperature		-40	-	+85	°C

13. Static characteristics

Table 79: Static characteristics: digital pins

Digital pins: A[17:1], DATA[31:0], CS_N, RD_N, WR_N, DACK, DREQ, IRQ, RESET_N, SUSPEND/WAKEUP_N, CLKIN, OC1_N, OC2_N, OC3_N.

OC1_N, OC2_N and OC3_N are used as digital overcurrent pins; $V_{CC(I/O)} = 3.0\text{ V to }3.6\text{ V}$; $T_{amb} = -40\text{ }^{\circ}\text{C to }+85\text{ }^{\circ}\text{C}$; unless otherwise specified

Symbol	Parameter	Conditions	Min	Typ	Max	Unit
V_{IH}	HIGH-level input voltage		2.0	-	-	V
V_{IL}	LOW-level input voltage		-	-	0.8	V
V_{hys}	hysteresis voltage		0.4	-	0.7	V
V_{OL}	LOW-level output voltage	$I_{OL} = 3\text{ mA}$	-	-	0.4	V
V_{OH}	HIGH-level output voltage		2.4	-	-	V
I_{IL}	input leakage current	$0 < V_{IN} < V_{CC(I/O)}$	-	-	1	μA
C_{IN}	input pin capacitance		-	2.75	-	pF

Table 80: Static characteristics: digital pins

Digital pins: A[17:1], DATA[31:0], CS_N, RD_N, WR_N, DACK, DREQ, IRQ, RESET_N, SUSPEND/WAKEUP_N, CLKIN, OC1_N, OC2_N, OC3_N.

OC1_N, OC2_N and OC3_N are used as digital overcurrent pins; $V_{CC(I/O)} = 1.65\text{ V to }1.95\text{ V}$; $T_{amb} = -40\text{ }^{\circ}\text{C to }+85\text{ }^{\circ}\text{C}$; unless otherwise specified.

Symbol	Parameter	Conditions	Min	Typ	Max	Unit
V_{IH}	HIGH-level input voltage		1.2	-	-	V
V_{IL}	LOW-level input voltage		-	-	0.5	V
V_{hys}	hysteresis voltage		0.4	-	0.7	V
V_{OL}	LOW-level output voltage	$I_{OL} = 3\text{ mA}$	-	-	$0.22V_{CC(I/O)}$	V
V_{OH}	HIGH-level output voltage		$0.8V_{CC(I/O)}$	-	-	V
I_{IL}	input leakage current	$0 < V_{IN} < V_{CC(I/O)}$	-	-	1	μA
C_{IN}	input pin capacitance		-	2.75	-	pF

Table 81: Static characteristics: PSW1_N, PSW2_N, PSW3_N

$V_{CC(I/O)} = 1.65\text{ V to }3.6\text{ V}$; $T_{amb} = -40\text{ }^{\circ}\text{C to }+85\text{ }^{\circ}\text{C}$; unless otherwise specified.

Symbol	Parameter	Conditions	Min	Typ	Max	Unit
V_{OL}	LOW-level output voltage	$I_{OL} = 8\text{ mA}$, pull-up to $V_{CC(5V0)}$	-	-	0.4	V
V_{OH}	HIGH-level output voltage	pull-up to $V_{CC(I/O)}$	-	$V_{CC(I/O)}$	-	V

Table 82: Static characteristics: USB interface block (pins DM1 to DM3 and DP1 to DP3)

$V_{CC(I/O)} = 1.65\text{ V to }3.6\text{ V}$; $T_{amb} = -40\text{ }^{\circ}\text{C to }+85\text{ }^{\circ}\text{C}$; unless otherwise specified.

Symbol	Parameter	Conditions	Min	Typ	Max	Unit
Input levels for high-speed						
V_{HSSQ}	squelch detection threshold (differential signal amplitude)	squelch detected	-	-	100	mV
		no squelch detected	150	-	-	mV
V_{HSDSC}	disconnect detection threshold (differential signal amplitude)	disconnect detected	625	-	-	mV
		disconnect not detected	-	-	525	mV
V_{HSCM}	data signaling common mode voltage range		-50	-	+500	mV

Table 82: Static characteristics: USB interface block (pins DM1 to DM3 and DP1 to DP3)...continued $V_{CC(I/O)} = 1.65\text{ V to }3.6\text{ V}$; $T_{amb} = -40\text{ }^{\circ}\text{C to }+85\text{ }^{\circ}\text{C}$; unless otherwise specified.

Symbol	Parameter	Conditions	Min	Typ	Max	Unit
Output levels for high-speed						
V_{HSOI}	idle state		-10	-	+10	mV
V_{HSOH}	data signaling HIGH		360	-	440	mV
V_{HSOL}	data signaling LOW		-10	-	+10	mV
V_{CHIRPJ}	Chirp J level (differential voltage)		700 [1]	-	1100	mV
V_{CHIRPK}	Chirp K level (differential voltage)		-900 [1]	-	-500	mV
Input levels for full-speed and low-speed						
V_{IH}	HIGH-level input voltage (drive)		2.0	-	-	V
V_{IHZ}	HIGH-level input voltage (floating)		2.7	-	3.6	V
V_{IL}	LOW-level input voltage		-	-	0.8	V
V_{DI}	differential input sensitivity	$ V_{DP} - V_{DM} $	0.2	-	-	V
V_{CM}	differential common mode range		0.8	-	2.5	V
Output levels for full-speed and low-speed						
V_{OH}	HIGH-level output voltage		2.8	-	3.6	V
V_{OL}	LOW-level output voltage		0	-	0.3	V
V_{OSEI}	SEI		0.8	-	-	V
V_{CRS}	output signal crossover point voltage		1.3	-	2.0	V

[1] The HS termination resistor is disabled, and the pull-up resistor is connected. Only during reset, when both the hub and the device are capable of the high-speed operation.

Table 83: Static characteristics: REF5V $V_{CC(I/O)} = 1.65\text{ V to }3.6\text{ V}$; $T_{amb} = -40\text{ }^{\circ}\text{C to }+85\text{ }^{\circ}\text{C}$; unless otherwise specified.

Symbol	Parameter	Conditions	Min	Typ	Max	Unit
V_{IH}	HIGH-level input voltage		-	5	-	V

14. Dynamic characteristics

Table 84: Dynamic characteristics: system clock timing

Symbol	Parameter	Conditions	Min	Typ	Max	Unit
Crystal oscillator						
f _{clk}	clock frequency [1]	crystal [2]	-	12	-	MHz
		oscillator	-	12	-	MHz
External clock input						
J	external clock jitter		-	-	500	ps
δ	clock duty cycle		-	50	-	%
V _{clk}	amplitude		-	1.8	-	V
t _{CR} , t _{CF}	rise time and fall time		-	-	3	ns

[1] Recommended accuracy of the clock frequency is 50 ppm for the crystal and oscillator. The oscillator used depends on V_{CC(I/O)}.

[2] Recommended values for external capacitors when using a crystal are 22 pF to 27 pF.

Table 85: Dynamic characteristics: CPU interface block

V_{CC(I/O)} = 1.65 V to 3.6 V; T_{amb} = -40 °C to +85 °C; unless otherwise specified.

Symbol	Parameter	Conditions	Min	Typ	Max	Unit
SR	output slew rate (rise, fall)	standard load	1	-	4	V/ns

Table 86: Dynamic characteristics: high-speed source electrical characteristics

V_{CC(I/O)} = 1.65 V to 3.6 V; T_{amb} = -40 °C to +85 °C; unless otherwise specified.

Symbol	Parameter	Conditions	Min	Typ	Max	Unit
Driver characteristics						
t _{HSR}	high-speed differential rise time	10 % to 90 %	500	-	-	ps
t _{HSF}	high-speed differential fall time	90 % to 10 %	500	-	-	ps
Z _{HSDRV}	drive output resistance (this also serves as a high-speed termination)	includes the R _S resistor	40.5	45	49.5	Ω
Clock timing						
t _{HSDRAT}	data rate		479.76	-	480.24	Mbit/s
t _{HSFRAM}	microframe interval		124.9375	-	125.0625	μs
t _{HSRFI}	consecutive microframe interval difference		1	-	four high-speed bit times	ns

Table 87: Dynamic characteristics: full-speed source electrical characteristics

V_{CC(I/O)} = 1.65 V to 3.6 V; T_{amb} = -40 °C to +85 °C; unless otherwise specified.

Symbol	Parameter	Conditions	Min	Typ	Max	Unit
Driver characteristics						
t _{FR}	rise time	C _L = 50 pF; 10 % to 90 % of V _{OH} - V _{OL}	4	-	20	ns
t _{FF}	fall time	C _L = 50 pF; 90 % to 10 % of V _{OH} - V _{OL}	4	-	20	ns
t _{FRFM}	differential rise and fall time matching		90	-	111.1	%

Table 87: Dynamic characteristics: full-speed source electrical characteristics...continued

$V_{CC(I/O)} = 1.65\text{ V to }3.6\text{ V}$; $T_{amb} = -40\text{ }^{\circ}\text{C to }+85\text{ }^{\circ}\text{C}$; unless otherwise specified.

Symbol	Parameter	Conditions	Min	Typ	Max	Unit
Z_{DRV}	driver output resistance for the driver that is not high-speed capable		28	-	44	Ω
Data timing: see Figure 11						
t_{FDEOP}	source jitter for differential transition to SEO transition	full-speed timing	-2	-	+5	ns
t_{FEOPT}	source SE0 interval of EOP		160	-	175	ns
t_{FEOPR}	receiver SE0 interval of EOP		82	-	-	ns
t_{LDEOP}	source jitter for differential transition to SEO transition	low-speed timing	-40	-	+100	ns
t_{LEOPT}	source SE0 interval of EOP		1.25	-	1.5	μs
t_{LEOPR}	receiver SE0 interval of EOP		670	-	-	ns
t_{FST}	width of SE0 interval during differential transaction		-	-	14	ns

Table 88: Dynamic characteristics: low-speed source electrical characteristics

$V_{CC(I/O)} = 1.65\text{ V to }3.6\text{ V}$; $T_{amb} = -40\text{ }^{\circ}\text{C to }+85\text{ }^{\circ}\text{C}$; unless otherwise specified.

Symbol	Parameter	Conditions	Min	Typ	Max	Unit
Driver characteristics						
t_{LR}	rise time		75	-	300	ns
t_{LF}	fall time		75	-	300	ns
t_{LRFM}	differential rise and fall time matching		90	-	125	%

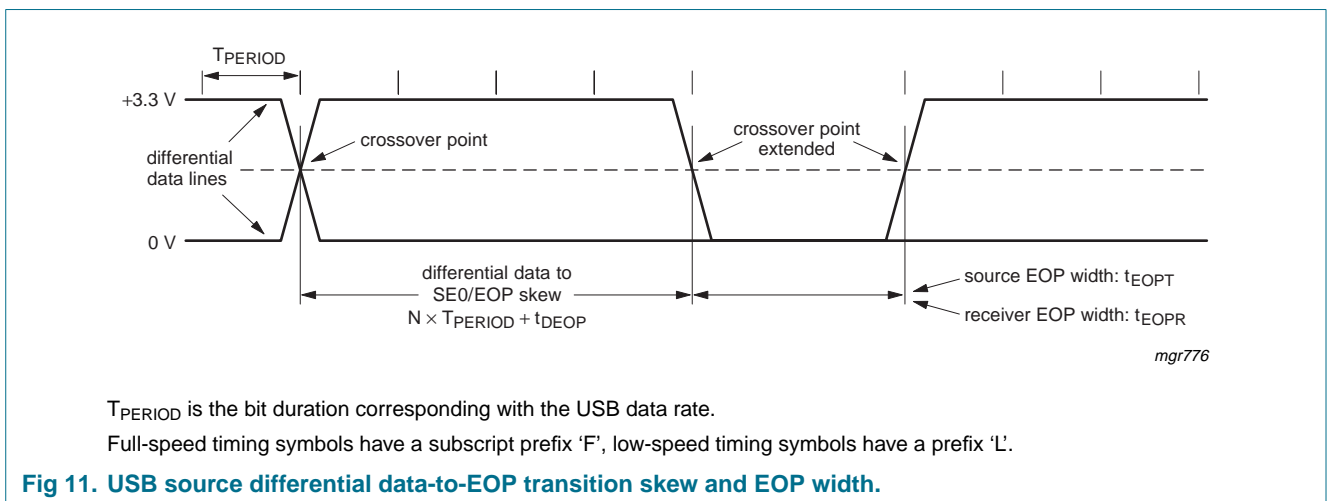

14.1 PIO timing

14.1.1 Register or memory write

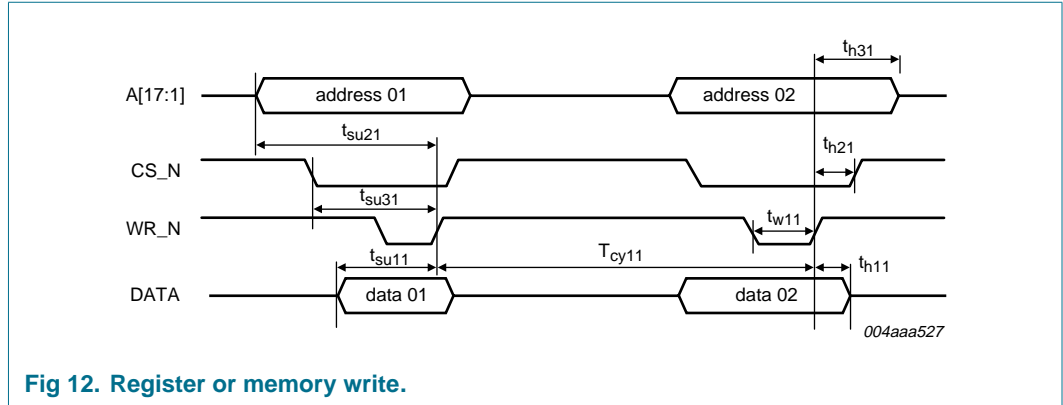

Fig 12. Register or memory write.

Table 89: Register or memory write

V_{CC(I/O)} = 1.65 V to 1.95 V; T_{amb} = -40 °C to +85 °C; unless otherwise specified.

Symbol	Parameter	Min	Max	Unit
t _{h11}	data hold after WR_N HIGH	2	-	ns
t _{h21}	CS_N hold after WR_N HIGH	1	-	ns
t _{h31}	address hold after WR_N HIGH	2	-	ns
t _{w11}	WR_N pulse width	17	-	ns
T _{cy11}	WR_N to WR_N cycle time	36	-	ns
t _{su11}	data set up time before WR_N HIGH	5	-	ns
t _{su21}	address set up time before WR_N HIGH	5	-	ns
t _{su31}	CS_N set up time before WR_N HIGH	5	-	ns

Table 90: Register or memory write

V_{CC(I/O)} = 3.3 V to 3.6 V; T_{amb} = -40 °C to +85 °C; unless otherwise specified.

Symbol	Parameter	Min	Max	Unit
t _{h11}	data hold after WR_N HIGH	2	-	ns
t _{h21}	CS_N hold after WR_N HIGH	1	-	ns
t _{h31}	address hold after WR_N HIGH	2	-	ns
t _{w11}	WR_N pulse width	17	-	ns
T _{cy11}	WR_N to WR_N cycle time	36	-	ns
t _{su11}	data set up time before WR_N HIGH	5	-	ns
t _{su21}	address set up time before WR_N HIGH	5	-	ns
t _{su31}	CS_N set up time before WR_N HIGH	5	-	ns

14.1.2 Register read

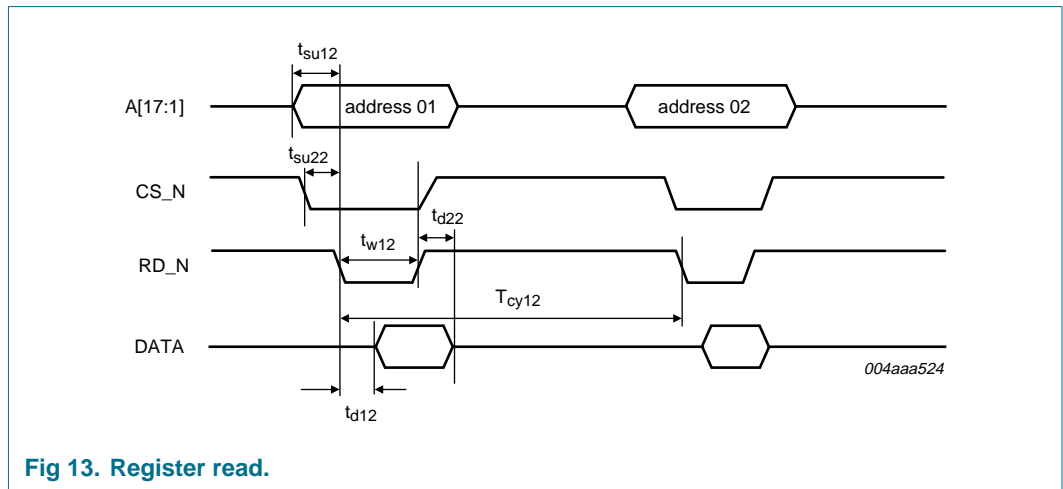

Fig 13. Register read.

Table 91: Register read

$V_{CC(I/O)} = 1.65\text{ V to }1.95\text{ V}$; $T_{amb} = -40\text{ }^{\circ}\text{C to }+85\text{ }^{\circ}\text{C}$; unless otherwise specified.

Symbol	Parameter	Min	Max	Unit
t_{su12}	address set up time before RD_N LOW	0	-	ns
t_{su22}	CS_N set up time before RD_N LOW	0	-	ns
t_{w12}	RD_N pulse width	t_{d12}	-	ns
t_{d12}	data valid time after RD_N LOW	-	35	ns
t_{d22}	data valid time after RD_N HIGH	-	1	ns
T_{cy12}	read-to-read cycle time	40	-	ns

Table 92: Register read

$V_{CC(I/O)} = 3.3\text{ V to }3.6\text{ V}$; $T_{amb} = -40\text{ }^{\circ}\text{C to }+85\text{ }^{\circ}\text{C}$; unless otherwise specified.

Symbol	Parameter	Min	Max	Unit
t_{su12}	address set up time before RD_N LOW	0	-	ns
t_{su22}	CS_N set up time before RD_N LOW	0	-	ns
t_{w12}	RD_N pulse width	t_{d12}	-	ns
t_{d12}	data valid time after RD_N LOW	-	22	ns
t_{d22}	data valid time after RD_N HIGH	-	1	ns
T_{cy12}	read-to-read cycle time	36	-	ns

14.1.3 Memory read

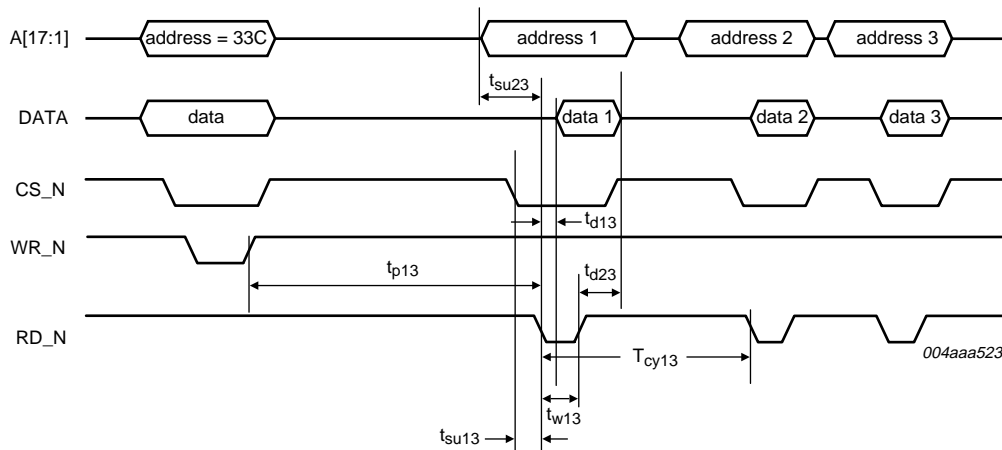

Fig 14. Memory read.

Table 93: Memory read

$V_{CC(I/O)} = 1.65\text{ V to }1.95\text{ V}$; $T_{amb} = -40\text{ }^{\circ}\text{C to }+85\text{ }^{\circ}\text{C}$; unless otherwise specified.

Symbol	Parameter	Min	Max	Unit
t_{p13}	initial prefetch time	90	-	ns
T_{cy13}	memory RD_N cycle time	40	-	ns
t_{d13}	data valid time after RD_N LOW	-	31	ns
t_{d23}	data available time after RD_N HIGH	-	1	ns
t_{w13}	RD_N pulse width	t_{d13}		ns
t_{su13}	CS_N setup time before RD_N LOW	0	-	ns
t_{su23}	address setup time before RD_N LOW	0	-	ns

Table 94: Memory read

$V_{CC(I/O)} = 3.3\text{ V to }3.6\text{ V}$; $T_{amb} = -40\text{ }^{\circ}\text{C to }+85\text{ }^{\circ}\text{C}$; unless otherwise specified.

Symbol	Parameter	Min	Max	Unit
t_{p13}	initial prefetch time	90	-	ns
T_{cy13}	memory RD_N cycle time	36	-	ns
t_{d13}	data valid time after RD_N LOW	-	20	ns
t_{d23}	data available time after RD_N HIGH	-	1	ns
t_{w13}	RD_N pulse width	t_{d13}		ns
t_{su13}	CS_N setup time before RD_N LOW	0	-	ns
t_{su23}	address setup time before RD_N LOW	0	-	ns

14.2 DMA timing

In the following sections:

- Polarity of DACK is active HIGH
- Polarity of DREQ is active HIGH.

14.2.1 Single cycle: DMA read

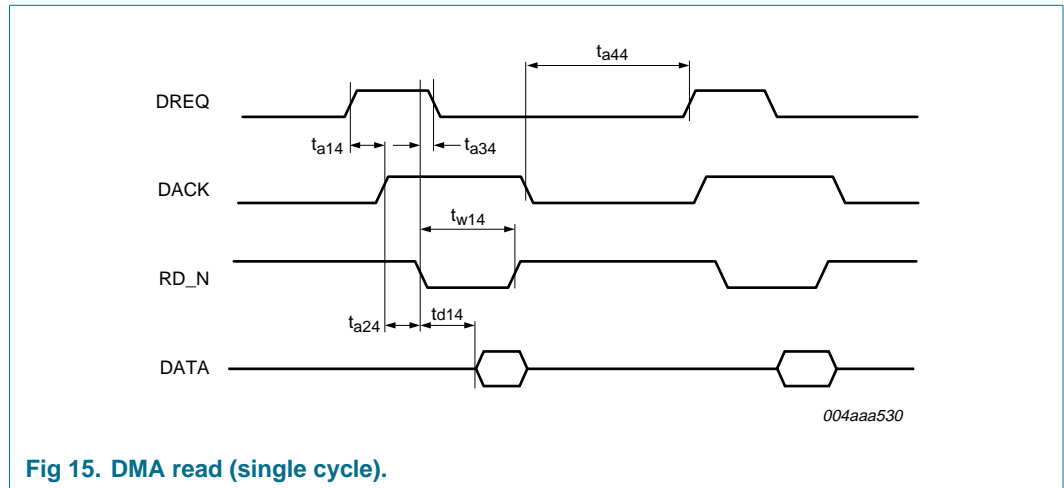

Fig 15. DMA read (single cycle).

Table 95: DMA read (single cycle)

$V_{CC(I/O)} = 1.65\text{ V to }1.95\text{ V}; T_{amb} = -40\text{ }^{\circ}\text{C to }+85\text{ }^{\circ}\text{C};$ unless otherwise specified.

Symbol	Parameter	Min	Max	Unit
t_{a14}	DACK assertion time after DREQ assertion	0	-	ns
t_{a24}	RD_N assertion time after DACK assertion	0	-	ns
t_{d14}	data valid time after RD_N assertion	-	24	ns
t_{w14}	RD_N pulse width	t_{d14}	-	ns
t_{a34}	DREQ deassertion time after RD_N assertion	23	-	ns
t_{a44}	DREQ deassertion to next DREQ assertion time	-	56	ns

Table 96: DMA read (single cycle)

$V_{CC(I/O)} = 3.3\text{ V to }3.6\text{ V}; T_{amb} = -40\text{ }^{\circ}\text{C to }+85\text{ }^{\circ}\text{C};$ unless otherwise specified.

Symbol	Parameter	Min	Max	Unit
t_{a14}	DACK assertion time after DREQ assertion	0	-	ns
t_{a24}	RD_N assertion time after DACK assertion	0	-	ns
t_{d14}	data valid time after RD_N assertion	-	20	ns
t_{w14}	RD_N pulse width	t_{d14}	-	ns
t_{a34}	DREQ deassertion time after RD_N assertion	11	-	ns
t_{a44}	DREQ deassertion to next DREQ assertion time	-	56	ns

14.2.2 Single cycle: DMA write

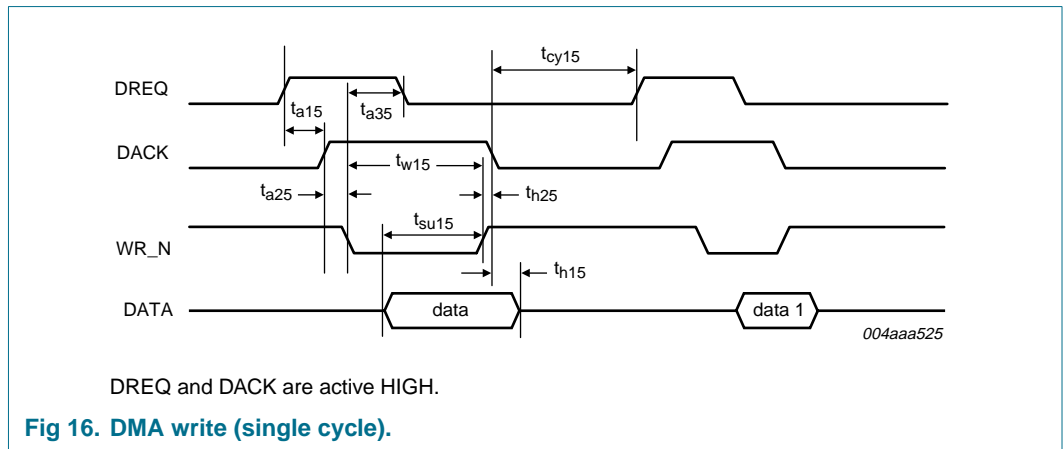

Table 97: DMA write (single cycle)

$V_{CC(I/O)} = 1.65\text{ V to }1.95\text{ V}; T_{amb} = -40\text{ }^{\circ}\text{C to }+85\text{ }^{\circ}\text{C};$ unless otherwise specified.

Symbol	Parameter	Min	Max	Unit
t _{a15}	DACK assertion time after DREQ assertion	0	-	ns
t _{a25}	WR_N assertion time after DACK assertion	1	-	ns
t _{h15}	data hold time after WR_N deassertion	3	-	ns
t _{h25}	DACK hold time after WR_N deassertion	0	-	ns
t _{su15}	data set-up time before WR_N deassertion	5.5	-	ns
t _{a35}	DREQ deassertion time after WR_N assertion	22	-	ns
t _{cy15}	last DACK strobe deassertion to next DREQ assertion time	82	-	ns
t _{w15}	WR_N pulse width	22	-	ns

Table 98: DMA write (single cycle)

$V_{CC(I/O)} = 3.3\text{ V to }3.6\text{ V}; T_{amb} = -40\text{ }^{\circ}\text{C to }+85\text{ }^{\circ}\text{C};$ unless otherwise specified.

Symbol	Parameter	Min	Max	Unit
t _{a15}	DACK assertion time after DREQ assertion	0	-	ns
t _{a25}	WR_N assertion time after DACK assertion	1	-	ns
t _{h15}	data hold time after WR_N deassertion	2	-	ns
t _{h25}	DACK hold time after WR_N deassertion	0	-	ns
t _{su15}	data set-up time before WR_N deassertion	5.5	-	ns
t _{a35}	DREQ deassertion time after WR_N assertion	8.9	-	ns
t _{cy15}	last DACK strobe deassertion to next DREQ assertion time	82	-	ns
t _{w15}	WR_N pulse width	22	-	ns

14.2.3 Multicycle: DMA read

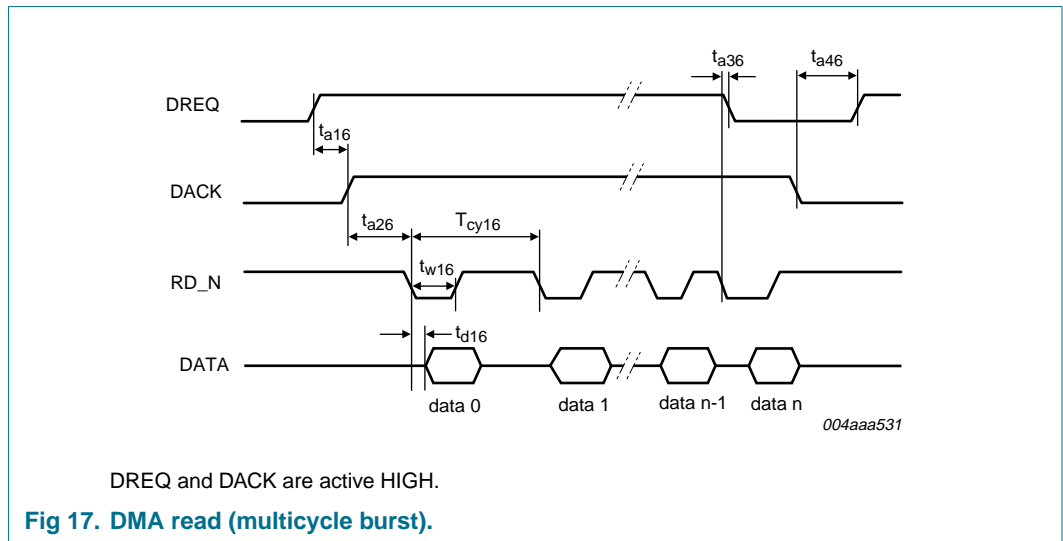

Table 99: DMA read (multicycle burst)

$V_{CC(I/O)} = 1.65\text{ V to }1.95\text{ V}; T_{amb} = -40\text{ }^{\circ}\text{C to }+85\text{ }^{\circ}\text{C};$ unless otherwise specified.

Symbol	Parameter	Min	Max	Unit
t_{a16}	DACK assertion after DREQ assertion time	0	-	ns
t_{a26}	RD_N assertion after DACK assertion time	0	-	ns
t_{d16}	data valid time after RD_N assertion	-	31	ns
t_{w16}	RD_N pulse width	t_{d16}	-	ns
T_{cy16}	read-to-read cycle time	40	-	ns
t_{a36}	DREQ deassertion time after last burst RD_N deassertion	20	-	ns
t_{a46}	DACK deassertion to next DREQ assertion time	-	82	ns

Table 100: DMA read (multicycle burst)

$V_{CC(I/O)} = 3.3\text{ V to }3.6\text{ V}; T_{amb} = -40\text{ }^{\circ}\text{C to }+85\text{ }^{\circ}\text{C};$ unless otherwise specified.

Symbol	Parameter	Min	Max	Unit
t_{a16}	DACK assertion after DREQ assertion time	0	-	ns
t_{a26}	RD_N assertion after DACK assertion time	0	-	ns
t_{d16}	data valid time after RD_N assertion	-	16	ns
t_{w16}	RD_N pulse width	t_{d16}	-	ns
T_{cy16}	read-to-read cycle time	36	-	ns
t_{a36}	DREQ deassertion time after last burst RD_N deassertion	11	-	ns
t_{a46}	DACK deassertion to next DREQ assertion time	-	82	ns

14.2.4 Multicycle: DMA write

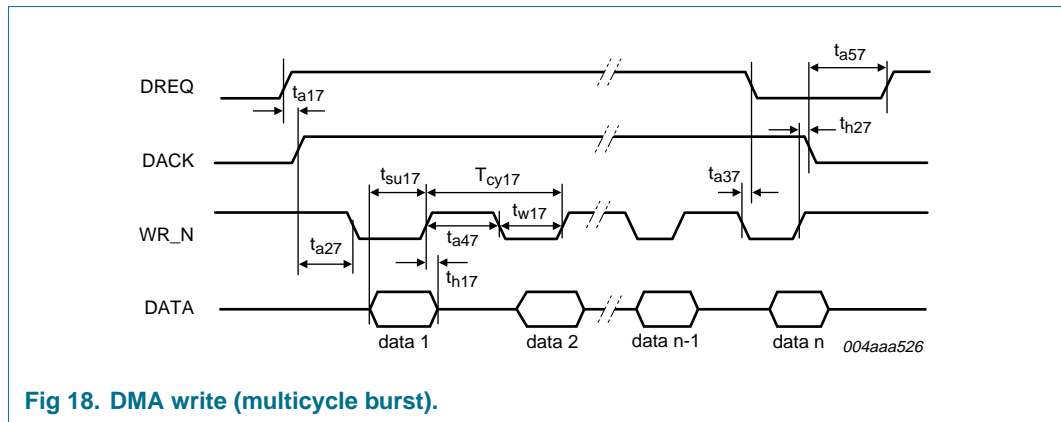

Fig 18. DMA write (multicycle burst).

Table 101: DMA write (multicycle burst)

$V_{CC(I/O)} = 1.65\text{ V to }1.95\text{ V}$; $T_{amb} = -40\text{ }^{\circ}\text{C to }+85\text{ }^{\circ}\text{C}$; unless otherwise specified.

Symbol	Parameter	Min	Max	Unit
T_{cy17}	DMA write cycle time	51	-	ns
t_{su17}	data setup time before WR_N deassertion	5	-	ns
t_{h17}	data hold time after WR_N deassertion	2	-	ns
t_{a17}	DACK assertion time after DREQ assertion	0	-	ns
t_{a27}	WR_N assertion time after DACK assertion	2	-	ns
t_{a37}	DREQ deassertion time at last strobe (WR_N) assertion	20	-	ns
t_{h27}	DACK hold time after WR_N deassertion	0	-	ns
t_{a47}	strobe deassertion to next strobe assertion time	34	-	ns
t_{w17}	WR_N pulse width	17	-	ns
t_{a57}	DACK deassertion to next DREQ assertion time	-	82	ns

Table 102: DMA write (multicycle burst)

$V_{CC(I/O)} = 3.3\text{ V to }3.6\text{ V}$; $T_{amb} = -40\text{ }^{\circ}\text{C to }+85\text{ }^{\circ}\text{C}$; unless otherwise specified.

Symbol	Parameter	Min	Max	Unit
T_{cy17}	DMA write cycle time	51	-	ns
t_{su17}	data setup time before WR_N deassertion	5	-	ns
t_{h17}	data hold time after WR_N deassertion	2	-	ns
t_{a17}	DACK assertion time after DREQ assertion	0	-	ns
t_{a27}	WR_N assertion time after DACK assertion	1	-	ns
t_{a37}	DREQ deassertion time at last strobe (WR_N) assertion	0	-	ns
t_{h27}	DACK hold time after WR_N deassertion	0	-	ns
t_{a47}	strobe deassertion to next strobe assertion time	34	-	ns
t_{w17}	WR_N pulse width	17	-	ns
t_{a57}	DACK deassertion to next DREQ assertion time	-	82	ns

15. Package outline

LQFP128: plastic low profile quad flat package; 128 leads; body 14 x 20 x 1.4 mm

SOT425-1

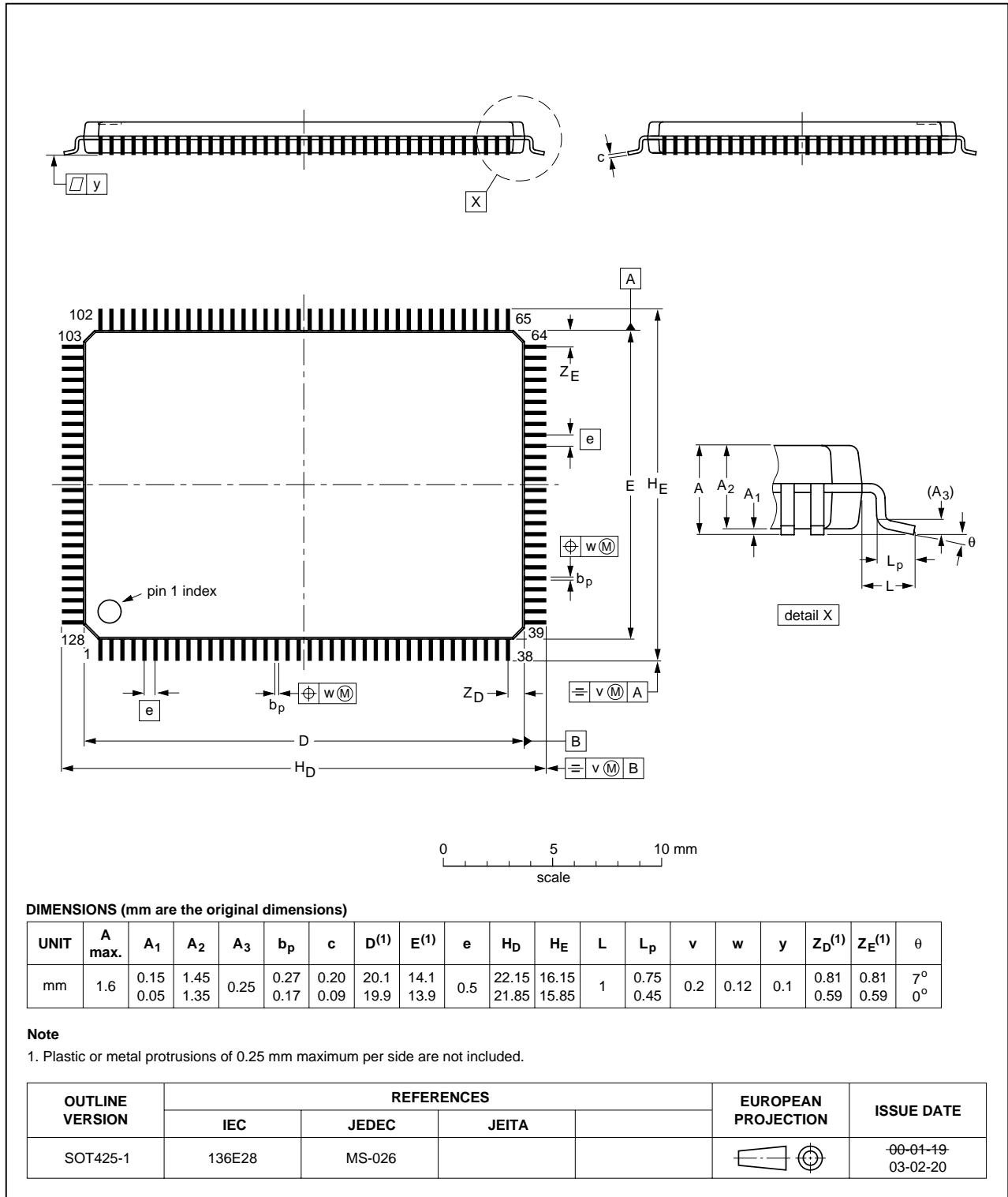

Fig 19. Package outline (LQFP128).

16. Soldering

16.1 Introduction to soldering surface mount packages

This text gives a very brief insight to a complex technology. A more in-depth account of soldering ICs can be found in our *Data Handbook IC26; Integrated Circuit Packages* (document order number 9398 652 90011).

There is no soldering method that is ideal for all surface mount IC packages. Wave soldering can still be used for certain surface mount ICs, but it is not suitable for fine pitch SMDs. In these situations reflow soldering is recommended.

16.2 Reflow soldering

Reflow soldering requires solder paste (a suspension of fine solder particles, flux and binding agent) to be applied to the printed-circuit board by screen printing, stencilling or pressure-syringe dispensing before package placement. Driven by legislation and environmental forces the worldwide use of lead-free solder pastes is increasing.

Several methods exist for reflowing; for example, convection or convection/infrared heating in a conveyor type oven. Throughput times (preheating, soldering and cooling) vary between 100 and 200 seconds depending on heating method.

Typical reflow peak temperatures range from 215 to 270 °C depending on solder paste material. The top-surface temperature of the packages should preferably be kept:

- below 225 °C (SnPb process) or below 245 °C (Pb-free process)
 - for all BGA, HTSSON..T and SSOP..T packages
 - for packages with a thickness ≥ 2.5 mm
 - for packages with a thickness < 2.5 mm and a volume ≥ 350 mm³ so called thick/large packages.
- below 240 °C (SnPb process) or below 260 °C (Pb-free process) for packages with a thickness < 2.5 mm and a volume < 350 mm³ so called small/thin packages.

Moisture sensitivity precautions, as indicated on packing, must be respected at all times.

16.3 Wave soldering

Conventional single wave soldering is not recommended for surface mount devices (SMDs) or printed-circuit boards with a high component density, as solder bridging and non-wetting can present major problems.

To overcome these problems the double-wave soldering method was specifically developed.

If wave soldering is used the following conditions must be observed for optimal results:

- Use a double-wave soldering method comprising a turbulent wave with high upward pressure followed by a smooth laminar wave.
- For packages with leads on two sides and a pitch (e):
 - larger than or equal to 1.27 mm, the footprint longitudinal axis is **preferred** to be parallel to the transport direction of the printed-circuit board;

- smaller than 1.27 mm, the footprint longitudinal axis **must** be parallel to the transport direction of the printed-circuit board.

The footprint must incorporate solder thieves at the downstream end.

- For packages with leads on four sides, the footprint must be placed at a 45° angle to the transport direction of the printed-circuit board. The footprint must incorporate solder thieves downstream and at the side corners.

During placement and before soldering, the package must be fixed with a droplet of adhesive. The adhesive can be applied by screen printing, pin transfer or syringe dispensing. The package can be soldered after the adhesive is cured.

Typical dwell time of the leads in the wave ranges from 3 to 4 seconds at 250 °C or 265 °C, depending on solder material applied, SnPb or Pb-free respectively.

A mildly-activated flux will eliminate the need for removal of corrosive residues in most applications.

16.4 Manual soldering

Fix the component by first soldering two diagonally-opposite end leads. Use a low voltage (24 V or less) soldering iron applied to the flat part of the lead. Contact time must be limited to 10 seconds at up to 300 °C.

When using a dedicated tool, all other leads can be soldered in one operation within 2 to 5 seconds between 270 and 320 °C.

16.5 Package related soldering information

Table 103: Suitability of surface mount IC packages for wave and reflow soldering methods

Package [1]	Soldering method	
	Wave	Reflow [2]
BGA, HTSSON..T [3], LBGA, LFBGA, SQFP, SSOP..T [3], TFBGA, USON, VFBGA	not suitable	suitable
DHVQFN, HBCC, HBGA, HLQFP, HSO, HSOP, HSQFP, HSSON, HTQFP, HTSSOP, HVQFN, HVSON, SMS	not suitable [4]	suitable
PLCC [5], SO, SOJ	suitable	suitable
LQFP, QFP, TQFP	not recommended [5] [6]	suitable
SSOP, TSSOP, VSO, VSSOP	not recommended [7]	suitable
CWQCCN..L [8], PMFP [9], WQCCN..L [8]	not suitable	not suitable

[1] For more detailed information on the BGA packages refer to the *(LF)BGA Application Note (AN01026)*; order a copy from your Philips Semiconductors sales office.

[2] All surface mount (SMD) packages are moisture sensitive. Depending upon the moisture content, the maximum temperature (with respect to time) and body size of the package, there is a risk that internal or external package cracks may occur due to vaporization of the moisture in them (the so called popcorn effect). For details, refer to the Drypack information in the *Data Handbook IC26; Integrated Circuit Packages; Section: Packing Methods*.

[3] These transparent plastic packages are extremely sensitive to reflow soldering conditions and must on no account be processed through more than one soldering cycle or subjected to infrared reflow soldering with peak temperature exceeding 217 °C ± 10 °C measured in the atmosphere of the reflow oven. The package body peak temperature must be kept as low as possible.

- [4] These packages are not suitable for wave soldering. On versions with the heatsink on the bottom side, the solder cannot penetrate between the printed-circuit board and the heatsink. On versions with the heatsink on the top side, the solder might be deposited on the heatsink surface.
- [5] If wave soldering is considered, then the package must be placed at a 45° angle to the solder wave direction. The package footprint must incorporate solder thieves downstream and at the side corners.
- [6] Wave soldering is suitable for LQFP, QFP and TQFP packages with a pitch (e) larger than 0.8 mm; it is definitely not suitable for packages with a pitch (e) equal to or smaller than 0.65 mm.
- [7] Wave soldering is suitable for SSOP, TSSOP, VSO and VSOP packages with a pitch (e) equal to or larger than 0.65 mm; it is definitely not suitable for packages with a pitch (e) equal to or smaller than 0.5 mm.
- [8] Image sensor packages in principle should not be soldered. They are mounted in sockets or delivered pre-mounted on flex foil. However, the image sensor package can be mounted by the client on a flex foil by using a hot bar soldering process. The appropriate soldering profile can be provided on request.
- [9] Hot bar soldering or manual soldering is suitable for PMFP packages.

17. Abbreviations

Table 104: Abbreviations

Acronym	Description
ATL	Acknowledged Transfer List
DMA	Direct Memory Access
DSC	Digital Still Camera
EHCI	Enhanced Host Controller Interface
EMI	Electro-Magnetic Interference
FS	full-speed
HC	Host Controller
HS	high-speed
INT	INTerrupt
ISO	isochronous
iTD	isochronous Transfer Descriptor
ITL	Isochronous (ISO) Transfer List
LS	low-speed
OHCI	Open Host Controller Interface
PDA	Personal Digital Assistant
PLL	Phase-Locked Loop
PIO	Programmed Input/Output
PTD	Philips Transfer Descriptor
QHA	Queue Head Asynchronous
QHP	Queue Head Periodic
QHA-SS/SC	Queue Head Asynchronous-Start Split/Start Complete
SiTD	Split isochronous Transfer Descriptor
TT	Transaction Translator
UHCI	Universal Host Controller Interface
USB	Universal Serial Bus

18. References

- [1] *Universal Serial Bus Specification Rev. 2.0*
- [2] *Enhanced Host Controller Interface Specification for Universal Serial Bus Rev. 1.0*
- [3] *On-The-Go Supplement to the USB Specification Rev. 1.0a*
- [4] *Embedded Systems Design with the ISP176x (AN10043)*
- [5] *ISP176x Linux Programming Guide (AN10042)*
- [6] *Interfacing the ISP176x to the Intel® PXA250 Processor (AN10037).*

19. Revision history

Table 105: Revision history

Document ID	Release date	Data sheet status	Change notice	Doc. number	Supersedes
ISP1760_1	20041108	Product data sheet	-	9397 750 13257	-

20. Data sheet status

Level	Data sheet status ^[1]	Product status ^{[2] [3]}	Definition
I	Objective data	Development	This data sheet contains data from the objective specification for product development. Philips Semiconductors reserves the right to change the specification in any manner without notice.
II	Preliminary data	Qualification	This data sheet contains data from the preliminary specification. Supplementary data will be published at a later date. Philips Semiconductors reserves the right to change the specification without notice, in order to improve the design and supply the best possible product.
III	Product data	Production	This data sheet contains data from the product specification. Philips Semiconductors reserves the right to make changes at any time in order to improve the design, manufacturing and supply. Relevant changes will be communicated via a Customer Product/Process Change Notification (CPCN).

[1] Please consult the most recently issued data sheet before initiating or completing a design.

[2] The product status of the device(s) described in this data sheet may have changed since this data sheet was published. The latest information is available on the Internet at URL <http://www.semiconductors.philips.com>.

[3] For data sheets describing multiple type numbers, the highest-level product status determines the data sheet status.

21. Definitions

Short-form specification — The data in a short-form specification is extracted from a full data sheet with the same type number and title. For detailed information see the relevant data sheet or data handbook.

Limiting values definition — Limiting values given are in accordance with the Absolute Maximum Rating System (IEC 60134). Stress above one or more of the limiting values may cause permanent damage to the device. These are stress ratings only and operation of the device at these or at any other conditions above those given in the Characteristics sections of the specification is not implied. Exposure to limiting values for extended periods may affect device reliability.

Application information — Applications that are described herein for any of these products are for illustrative purposes only. Philips Semiconductors make no representation or warranty that such applications will be suitable for the specified use without further testing or modification.

customers using or selling these products for use in such applications do so at their own risk and agree to fully indemnify Philips Semiconductors for any damages resulting from such application.

Right to make changes — Philips Semiconductors reserves the right to make changes in the products - including circuits, standard cells, and/or software - described or contained herein in order to improve design and/or performance. When the product is in full production (status 'Production'), relevant changes will be communicated via a Customer Product/Process Change Notification (CPCN). Philips Semiconductors assumes no responsibility or liability for the use of any of these products, conveys no license or title under any patent, copyright, or mask work right to these products, and makes no representations or warranties that these products are free from patent, copyright, or mask work right infringement, unless otherwise specified.

23. Trademarks

Intel — is a registered trademark of Intel Corporation.

22. Disclaimers

Life support — These products are not designed for use in life support appliances, devices, or systems where malfunction of these products can reasonably be expected to result in personal injury. Philips Semiconductors

24. Contact information

For additional information, please visit: <http://www.semiconductors.philips.com>

For sales office addresses, send an email to: sales.addresses@www.semiconductors.philips.com

25. Tables

Table 1: Ordering information	3	Table 48: DMA Start Address register: bit allocation	46
Table 2: Pin description	5	Table 49: DMA Start Address register: bit description	46
Table 3: Memory address	15	Table 50: Power Down Control register: bit allocation	47
Table 4: Using the IRQ Mask AND or IRQ Mask OR registers	21	Table 51: Power Down Control register: bit description	47
Table 5: Register overview	27	Table 52: Port 1 Control register: bit allocation	49
Table 6: CAPLENGTH register: bit description	28	Table 53: Port 1 Control register: bit description	49
Table 7: HCVERSION register: bit description	28	Table 54: Interrupt register: bit allocation	50
Table 8: HCSPARAMS register: bit allocation	28	Table 55: Interrupt register: bit description	50
Table 9: HCSPARAMS register: bit description	29	Table 56: Interrupt Enable register: bit allocation	51
Table 10: HCCPARAMS register: bit allocation	29	Table 57: Interrupt Enable register: bit description	52
Table 11: HCCPARAMS register: bit description	30	Table 58: ISO IRQ Mask OR register: bit description	53
Table 12: USBCMD register: bit allocation	31	Table 59: INT IRQ Mask OR register: bit description	53
Table 13: USBCMD register: bit description	31	Table 60: ATL IRQ Mask OR register: bit description	54
Table 14: USBSTS register: bit allocation	32	Table 61: ISO IRQ Mask AND register: bit description	54
Table 15: USBSTS register: bit description	32	Table 62: INT IRQ Mask AND register: bit description	54
Table 16: USBINTR register: bit allocation	32	Table 63: ATL IRQ Mask AND register: bit description	55
Table 17: USBINTR register: bit description	33	Table 64: High-speed bulk IN and OUT, QHA: bit allocation	58
Table 18: FRINDEX register: bit allocation	33	Table 65: High-speed bulk IN and OUT, QHA: bit description	59
Table 19: FRINDEX register: bit description	34	Table 66: High-speed isochronous IN and OUT, iTD: bit allocation	62
Table 20: CONFIGFLAG register: bit allocation	34	Table 67: High-speed isochronous IN and OUT, iTD: bit description	63
Table 21: CONFIGFLAG register: bit description	35	Table 68: High-speed interrupt IN and OUT, QHP: bit allocation	66
Table 22: PORTSC1 register: bit allocation	35	Table 69: High-speed interrupt IN and OUT, QHP: bit description	67
Table 23: PORTSC1 register: bit description	36	Table 70: Start and complete split for bulk, QHASS/SC: bit allocation	70
Table 24: ISO PTD Done Map register: bit description	37	Table 71: Start and complete split for bulk, QHASS/SC: bit description	71
Table 25: ISO PTD Skip Map register: bit description	37	Table 72: Start and complete split for isochronous, SiTD: bit allocation	74
Table 26: ISO PTD Last PTD register: bit description	37	Table 73: Start and complete split for isochronous, SiTD: bit description	75
Table 27: INT PTD Done Map register: bit description	37	Table 74: Start and complete split for interrupt: bit allocation	78
Table 28: INT PTD Skip Map register: bit description	38	Table 75: Start and complete split for interrupt: bit description	79
Table 29: INT PTD Last PTD register: bit description	38	Table 76: Power consumption	82
Table 30: ATL PTD Done Map register: bit description	38	Table 77: Absolute maximum ratings	83
Table 31: ATL PTD Skip Map register: bit description	39	Table 78: Recommended operating conditions	83
Table 32: ATL PTD Last PTD register: bit description	39	Table 79: Static characteristics: digital pins	84
Table 33: HW Mode Control register: bit allocation	39	Table 80: Static characteristics: digital pins	84
Table 34: HW Mode Control register: bit description	40	Table 81: Static characteristics: PSW1_N, PSW2_N, PSW3_N	84
Table 35: Chip ID register: bit description	41	Table 82: Static characteristics: USB interface block (pins)	
Table 36: Scratch register: bit description	41		
Table 37: SW Reset register: bit allocation	41		
Table 38: SW Reset register: bit description	42		
Table 39: DMA Configuration register: bit allocation	42		
Table 40: DMA Configuration register: bit description	43		
Table 41: Buffer Status register: bit allocation	43		
Table 42: Buffer Status register: bit description	44		
Table 43: ATL Done Timeout register: bit description	44		
Table 44: Memory register: bit allocation	44		
Table 45: Memory register: bit description	45		
Table 46: Edge Interrupt Count register: bit allocation	45		
Table 47: Edge Interrupt Count register: bit description	46		

continued >>

DM1 to DM3 and DP1 to DP3)84

Table 83: Static characteristics: REF5V85

Table 84: Dynamic characteristics: system clock timing .86

Table 85: Dynamic characteristics: CPU interface block .86

Table 86: Dynamic characteristics: high-speed source
electrical characteristics86

Table 87: Dynamic characteristics: full-speed source
electrical characteristics86

Table 88: Dynamic characteristics: low-speed source
electrical characteristics87

Table 89: Register or memory write88

Table 90: Register or memory write88

Table 91: Register read89

Table 92: Register read89

Table 93: Memory read90

Table 94: Memory read90

Table 95: DMA read (single cycle)91

Table 96: DMA read (single cycle)91

Table 97: DMA write (single cycle)92

Table 98: DMA write (single cycle)92

Table 99: DMA read (multicycle burst)93

Table 100: DMA read (multicycle burst)93

Table 101: DMA write (multicycle burst)94

Table 102: DMA write (multicycle burst)94

Table 103: Suitability of surface mount IC packages for wave
and reflow soldering methods97

Table 104: Abbreviations98

Table 105: Revision history99

[continued >>](#)

26. Figures

Fig 1.	Block diagram.	4
Fig 2.	Pin configuration (LQFP128).	5
Fig 3.	Internal hub.	13
Fig 4.	Memory segmentation and access block diagram.	16
Fig 5.	Adjusting analog overcurrent detection limit (optional).	24
Fig 6.	ISP1760 power supply connection.	24
Fig 7.	Most commonly used power supply connection.	25
Fig 8.	Internal power-on reset timing.	25
Fig 9.	Clock with respect to the external power-on reset.	26
Fig 10.	NextPTD traversal rule.	57
Fig 11.	USB source differential data-to-EOP transition skew and EOP width.	87
Fig 12.	Register or memory write.	88
Fig 13.	Register read.	89
Fig 14.	Memory read.	90
Fig 15.	DMA read (single cycle).	91
Fig 16.	DMA write (single cycle).	92
Fig 17.	DMA read (multicycle burst).	93
Fig 18.	DMA write (multicycle burst).	94
Fig 19.	Package outline (LQFP128).	95

[continued >>](#)

27. Contents

1	General description	1	8.2.10	ISO PTD Last PTD register (R/W: 0138h) . . .	37
2	Features	1	8.2.11	INT PTD Done Map register (R: 0140h)	37
3	Applications	2	8.2.12	INT PTD Skip Map register (R/W: 0144h) . . .	38
3.1	Examples of a multitude of possible applications	2	8.2.13	INT PTD Last PTD register (R/W: 0148h) . . .	38
4	Ordering information	3	8.2.14	ATL PTD Done Map register (R: 0150h)	38
5	Block diagram	4	8.2.15	ATL PTD Skip Map register (R/W: 0154h) . . .	38
6	Pinning information	5	8.2.16	ATL PTD Last PTD register (R/W: 0158h) . . .	39
6.1	Pinning	5	8.3	Configuration registers	39
6.2	Pin description	5	8.3.1	HW Mode Control register (R/W: 0300h) . . .	39
7	Functional description	12	8.3.2	Chip ID register (R: 0304h)	41
7.1	ISP1760 internal architecture: Advanced Philips Slave Host Controller and hub	12	8.3.3	Scratch register (R/W: 0308h)	41
7.2	Host Controller buffer memory block	13	8.3.4	SW Reset register (R/W: 030Ch)	41
7.2.1	General considerations	13	8.3.5	DMA Configuration register (R/W: 0330h) . . .	42
7.2.2	Structure of the ISP1760 Host Controller memory	14	8.3.6	Buffer Status register (R/W: 0334h)	43
7.3	Accessing the ISP1760 Host Controller memory: PIO and DMA	16	8.3.7	ATL Done Timeout register (R/W: 0338h) . . .	44
7.3.1	PIO mode access—memory read cycle	17	8.3.8	Memory register (R/W: 033Ch)	44
7.3.2	PIO mode access—memory write cycle	17	8.3.9	Edge Interrupt Count register (R/W: 0340h) . .	45
7.3.3	PIO mode access—register read cycle	18	8.3.10	DMA Start Address register (W: 0344h)	46
7.3.4	PIO mode access—register write cycle	18	8.3.11	Power Down Control register (R/W: 0354h) . .	46
7.3.5	DMA—read and write operations	18	8.3.12	Port 1 Control register (R/W: 0374h)	48
7.4	Interrupts	19	8.4	Interrupt registers	50
7.5	Phase-Locked Loop (PLL) clock multiplier . . .	21	8.4.1	Interrupt register (R/W: 0310h)	50
7.6	Power management	22	8.4.2	Interrupt Enable register (R/W: 0314h)	51
7.7	Overcurrent detection	23	8.4.3	ISO IRQ Mask OR register (R/W: 0318h) . . .	53
7.8	Power supply	24	8.4.4	INT IRQ Mask OR register (R/W: 031Ch) . . .	53
7.9	Power-on reset (POR)	25	8.4.5	ATL IRQ Mask OR register (R/W: 0320h) . . .	53
8	Registers	27	8.4.6	ISO IRQ Mask AND register (R/W: 0324h) . .	54
8.1	EHCI capability registers	28	8.4.7	INT IRQ Mask AND register (R/W: 0328h) . .	54
8.1.1	CAPLENGTH register (R: 0000h)	28	8.4.8	ATL IRQ Mask AND register (R/W: 032Ch) . .	54
8.1.2	HCIVERSION register (R: 0002h)	28	9	Philips Transfer Descriptor	55
8.1.3	HCSPARAMS register (R: 0004h)	28	9.1	High-speed bulk IN and OUT, Queue Head Asynchronous (QHA) (patent-pending)	58
8.1.4	HCCPARAMS register (R: 0008h)	29	9.2	High-speed isochronous IN and OUT, isochronous Transfer Descriptor (iTd) (patent-pending)	62
8.2	EHCI operational registers	30	9.3	High-speed interrupt IN and OUT, Queue Head Periodic (QHP) (patent-pending)	66
8.2.1	USBCMD register (R/W: 0020h)	30	9.4	Start and complete split for bulk, Queue Head Asynchronous Start Split and Start Complete (QHA-SS/SC) (patent-pending)	70
8.2.2	USBSTS register (R/W: 0024h)	31	9.5	Start and complete split for isochronous, Split isochronous Transfer Descriptor (SiTD) (patent-pending)	74
8.2.3	USBINTR register (R/W: 0028h)	32	9.6	Start and complete split for interrupt (patent-pending)	78
8.2.4	FRINDEX register (R/W: 002Ch)	33	10	Power consumption	82
8.2.5	CTRLDSSEGMENT register (R/W: 0030h) . . .	34	11	Limiting values	83
8.2.6	CONFIGFLAG register (R/W: 0060h)	34			
8.2.7	PORTSC1 register (R/W: 0064h)	35			
8.2.8	ISO PTD Done Map register (R: 0130h)	36			
8.2.9	ISO PTD Skip Map register (R/W: 0134h) . . .	37			

continued >>

12	Recommended operating conditions	83
13	Static characteristics	84
14	Dynamic characteristics	86
14.1	PIO timing	88
14.1.1	Register or memory write	88
14.1.2	Register read	89
14.1.3	Memory read	90
14.2	DMA timing	91
14.2.1	Single cycle: DMA read	91
14.2.2	Single cycle: DMA write	92
14.2.3	Multicycle: DMA read	93
14.2.4	Multicycle: DMA write	94
15	Package outline	95
16	Soldering	96
16.1	Introduction to soldering surface mount packages	96
16.2	Reflow soldering	96
16.3	Wave soldering	96
16.4	Manual soldering	97
16.5	Package related soldering information	97
17	Abbreviations	98
18	References	99
19	Revision history	99
20	Data sheet status	100
21	Definitions	100
22	Disclaimers	100
23	Trademarks	100
24	Contact information	100



© Koninklijke Philips Electronics N.V. 2004

All rights are reserved. Reproduction in whole or in part is prohibited without the prior written consent of the copyright owner. The information presented in this document does not form part of any quotation or contract, is believed to be accurate and reliable and may be changed without notice. No liability will be accepted by the publisher for any consequence of its use. Publication thereof does not convey nor imply any license under patent- or other industrial or intellectual property rights.

Date of release: 8 November 2004
Document number: 9397 750 13257

Published in The Netherlands