

International
IOR Rectifier

SC070.....5. Series

SCHOTTKY DIE 70 x 92 mils

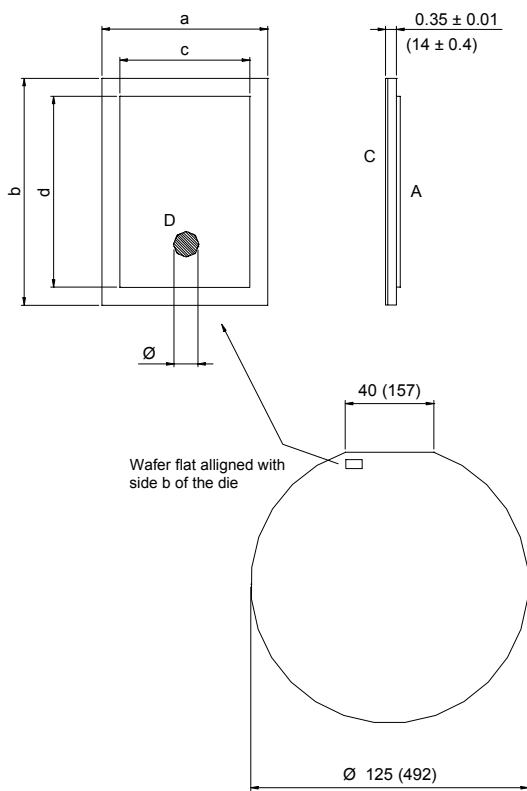

NOTES:

1. ALL DIMENSIONS ARE SHOWN IN MILLIMETERS (MILS).
2. CONTROLLING DIMENSION: (MILS).
3. DIMENSIONS AND TOLERANCES:
 - a = $1.78 + 0, - 0.01$
(70 + 0, - 0.4)
 - b = $2.34 + 0, - 0.01$
(92 + 0, - 0.4)
 - c = $1.63 + 0, - 0.01$
(64 + 0, - 0.4)
 - d = $2.18 + 0, - 0.01$
(86 + 0, - 0.4)
 - $\varnothing = 0.7 \pm 0.1$
(30 \pm 4)
4. LETTER DESIGNATION:
 - A = Anode (Top Metal)
 - C = Cathode (Back Metal)
 - D = Reject Ink Dot (only on non-conforming dies)
5. SAWING:
 - Recommended Blade
 - SEMITEC S1025 QS00 Blade
 - Sawing Street
 - $0.05 + 0, - 0.005$
 - (2 + 0, - 0.2)

NOT TO SCALE

NOTE: 10 mils die thickness is available on specific request only.
 Contact factory for information.

SC070.....5.

Bulletin I0509J rev.A 05/01

International
IR Rectifier

Electrical Characteristics

Device #	T _J Max. (°C)	V _R (V)	Typ. I _R @ 25°C (μA)	Typ. I _R @ 125°C (mA)	Max. V _F @ I _F (V)	Package Style
SC070R015x5x	125	15	n.a. contact factory			
SC070S020x5x	150	20	n.a. contact factory			
SC070S030x5x	150	30	90	38	0.55 @ 12A	DPAK(TO-252)
SC070S045x5x	150	45	70	32	0.70 @ 15A	TO-220
SC070S060x5x	150	60	n.a. contact factory			
SC070H045x5x	175	45	12	4	0.56 @ 15A	TO-220
SC070H100x5x	175	100	5	2.5	0.95 @ 12A	DPAK(TO-252)
SC070H150x5x	175	150	2	1.5	1.1 @ 10A	TO-220

Mechanical Data

Device #		Metal Thickness Front Metal			Metal Thickness Back Metal		
SC070xxxxA5x	Wire Bondable	–	Al 30 kÅ	–	Cr 1 kÅ	Ni 2 kÅ	Ag 3 kÅ
SC070xxxxS5x	Solderable	Ti 2 kÅ	Ni 1 kÅ	Ag 35 kÅ	Cr 1 kÅ	Ni 2 kÅ	Ag 3 kÅ

Recommended Storage Environment: Store in original container, in dessicated nitrogen, with no contamination.

Shelf life for parts stored in above condition is 2 years.

If the storage is done in normal atmosphere shelf life is reduced to six months.

Packaging

Device #	Description	Minimum Order Quantity Die in Sale Package
SC070xxxx5B	Inked Probed Unsawn Wafer (Wafer in Box)	2500
SC070xxxx5R	Probed Die in Tape & Reel	n.a
SC070xxxx5P	Probed Die in Waffle Pack	2500
SC070xxxx5F	Inked Probed Sawn Wafer on Film	2500

Ordering Information Table

Device Code						
SC	070	S	045	A	5	B
①	②	③	④	⑤	⑥	⑦

- 1** - Schottky Die
- 2** - Chip Dimension in Mils
- 3** - Process (see Electrical Characteristics Table)
- 4** - Voltage code: Code = V_{RRM}
- 5** - Chip surface metallization (see Mechanical Data Table)
- 6** - Wafer Diameter in inches
- 7** - Packaging (see Packaging Table)

H = 830 Process
 R = OR'ing Process
 S = Standard Process

Wafer on Film

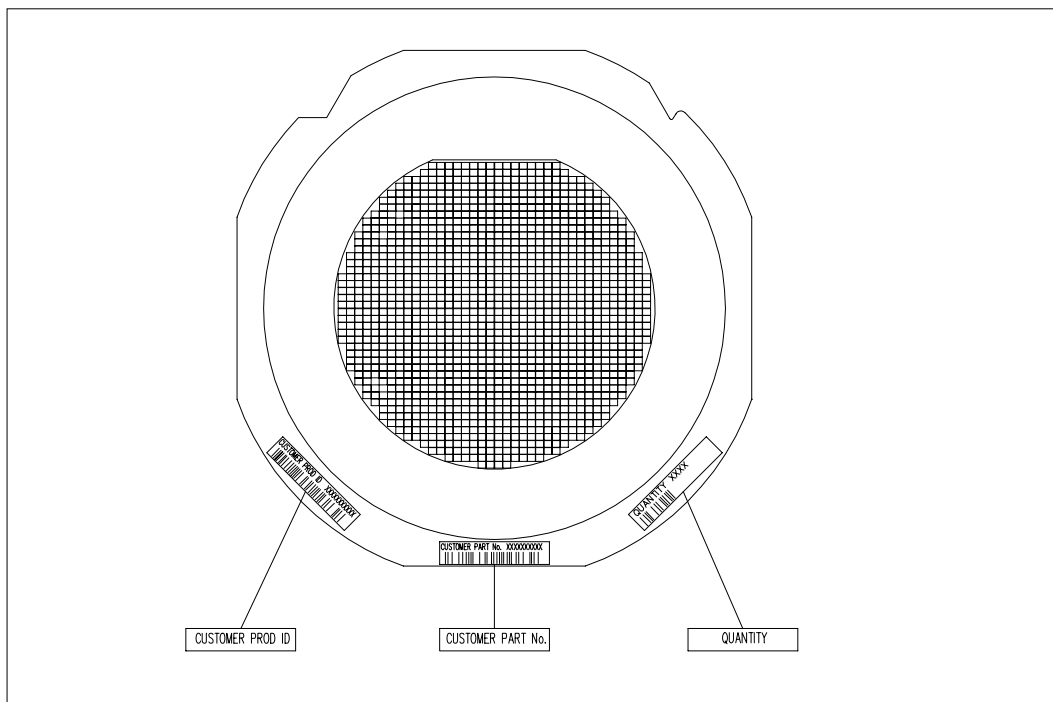

SC070.....5.

Bulletin I0509J rev.A 05/01

International
IRF Rectifier

Wafer in Box

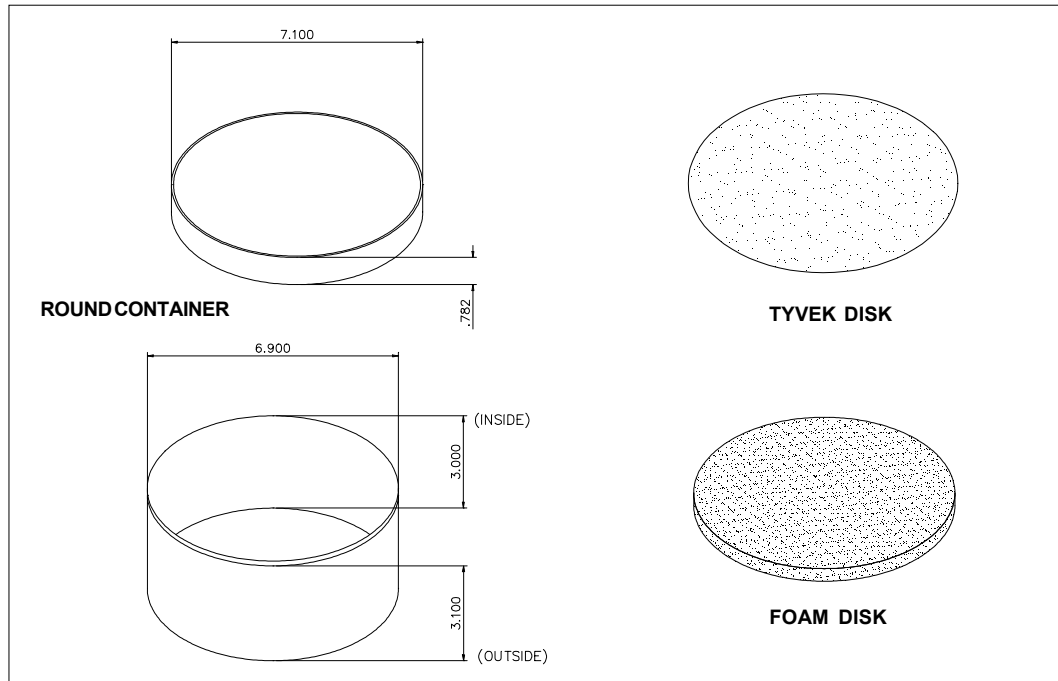

Die in Waffle Pack

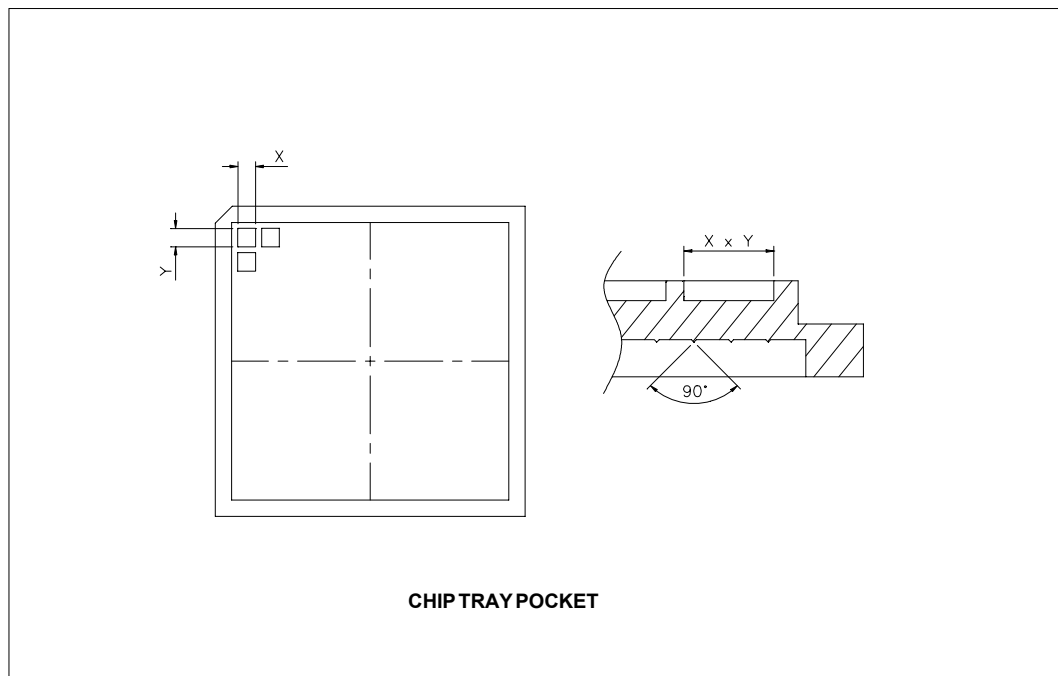

WORLD HEADQUARTERS: 233 Kansas St., El Segundo, California 90245 U.S.A. Tel: (310) 322 3331. Fax: (310) 322 3332.
EUROPEAN HEADQUARTERS: Hurst Green, Oxted, Surrey RH8 9BB, U.K. Tel: ++ 44 1883 732020. Fax: ++ 44 1883 733408.
IR CANADA: 15 Lincoln Court, Brampton, Markham, Ontario L6T3Z2. Tel: (905) 453 2200. Fax: (905) 475 8801.
IR GERMANY: Saalburgstrasse 157, 61350 Bad Homburg. Tel: ++ 49 6172 96590. Fax: ++ 49 6172 965933.
IR ITALY: Via Liguria 49, 10071 Borgaro, Torino. Tel: ++ 39 11 4510111. Fax: ++ 39 11 4510220.
IR FAR EAST: K&H Bldg., 2F, 30-4 Nishi-Ikebukuro 3-Chome, Toshima-Ku, Tokyo, Japan 171. Tel: 81 3 3983 0086.
IR SOUTHEAST ASIA: 1 Kim Seng Promenade, Great World City West Tower, 13-11, Singapore 237994. Tel: ++ 65 838 4630.
IR TAIWAN: 16 Fl. Suite D.207, Sec. 2, Tun Haw South Road, Taipei, 10673, Taiwan. Tel: 886 2 2377 9936.

<http://www.irf.com>

Fax-On-Demand: +44 1883 733420

Data and specifications subject to change without notice.