

Product Specification

Model No.: **97G104V1N0F-2**

Description: **10.4" TFT-LCD Panel
+ 4 wires touch**

Document No.: **DOC-50-100182**

Version: **0.1**

Total Pages: **25**

Date: **April.8th,2010**

	Name	Date	Department
Prepared By	Perry Chen	2010/04/08	<input checked="" type="checkbox"/> PM <input type="checkbox"/> R&D
Checked By	Pamela Lin	2010/04/08	<input checked="" type="checkbox"/> PM <input type="checkbox"/> R&D
Approved By	Davis Weng	2010/04/08	<input type="checkbox"/> PM <input checked="" type="checkbox"/> R&D

ALL RIGHTS STRICTLY RESERVED. ANY PORTION OF THIS PAPER SHALL NOT BE REPRODUCED, COPIED, OR TRANSFORMED TO ANY OTHER FORMS WITHOUT PERMISSION FROM PROMATE ELECTRONIC CO., LTD.

Contents

1. OPERATING PRECAUTIONS	5
2. GENERAL DESCRIPTION	6
2.1 DISPLAY CHARACTERISTICS	6
2.2 OPTICAL CHARACTERISTICS	7
3. FUNCTIONAL BLOCK DIAGRAM	10
4. ABSOLUTE MAXIMUM RATINGS	10
4.1 ABSOLUTE RATINGS OF TFT LCD MODULE	10
4.2 ABSOLUTE RATINGS OF ENVIRONMENT	10
5. ELECTRICAL CHARACTERISTICS	9
5.1 TFT LCD MODULE	10
5.2 BACKLIGHT UNIT	12
6. SIGNAL CHARACTERISTICS	13
6.1 PIXEL FORMAT IMAGE	13
6.2 SCANNING DIRECTION	13
6.3 THE INPUT DATA FORMAT	14
6.4 TFT-LCD INTERFACE SIGNAL DESCRIPTION	15
6.5 TFT-LCD INTERFACE TIMING	16
6.6 POWER ON/OFF SEQUENCE	18
7. CONNECTOR & PIN ASSIGNMENT.....	19
7.1 TFT LCD SIGNAL (CN1): LCD CONNECTOR.....	19
7.2 LED BACKLIGHT UNIT (CN2): BACKLIGHT CONNECTOR.....	19
7.3 LED BACKLIGHT UNIT (CN4): LIGHT BAR CONNECTOR	19
8. TOUCH PANEL SPECIFICATION	20
8.1 OPERATING CONDITION.....	20
8.2 ELECTRICAL CHARACTERISTIC	20
8.3 MECHANICAL CHARACTERISTIC.....	20
9. RELIABILITY TEST CRITERIA	20
10. DISPLAY QUALITY.....	20

ALL RIGHTS STRICTLY RESERVED. ANY PORTION OF THIS PAPER SHALL NOT BE REPRODUCED, COPIED, OR TRANSFORMED TO ANY OTHER FORMS WITHOUT PERMISSION FROM PROMATE ELECTRONIC CO., LTD. 2

11. MECHANICAL CHARACTERISTICS	21
11.1 LCM OUTLINE DIMENSION (FRONT VIEW).....	21
11.2 LCM OUTLINE DIMENSION (REAR VIEW)	23
11.3 TOUCH SENSOR OUTLINE DIMENSION	24
11.4 MECHANICAL ASSEMBLY DRAWING	24

1. Operating Precautions

- 1) Since front polarizer is easily damaged, please be cautious and not to scratch it.
- 2) Be sure to turn off power supply when inserting or disconnecting from input connector.
- 3) Wipe off water drop immediately. Long contact with water may cause discoloration or spots.
- 4) When the panel surface is soiled, wipe it with absorbent cotton or soft cloth.
- 5) Since the panel is made of glass, it may be broken or cracked if dropped or bumped on hard surface.
- 6) To avoid ESD (Electro Static Discharge) damage, be sure to ground yourself before handling TFT-LCD Module.
- 7) Do not open nor modify the module assembly.
- 8) Do not press the reflector sheet at the back of the module to any direction.
- 9) In case if a module has to be put back into the packing container slot after it was taken out from the container, do not press the center of the LED light bar edge. Instead, press at the far ends of the LED light bar edge softly. Otherwise the TFT Module may be damaged.
- 10) At the insertion or removal of the Signal Interface Connector, be sure not to rotate nor tilt the Interface Connector of the TFT Module.
- 11) TFT-LCD Module is not allowed to be twisted & bent even force is added on module in a very short time. Please design your display product well to avoid external force applying to module by end-user directly.
- 12) Small amount of materials without flammability grade are used in the TFT-LCD module. The TFT-LCD module should be supplied by power complied with requirements of Limited Power Source (IEC60950 or UL1950), or be applied exemption.
- 13) Severe temperature condition may result in different luminance, response time and lamp ignition voltage.
- 14) Continuous operating TFT-LCD display under low temperature environment may accelerate lamp exhaustion and reduce luminance dramatically.
- 15) The data on this specification sheet is applicable when LCD module is placed in landscape position.
- 16) Continuous displaying fixed pattern may induce image sticking. It's recommended to use screen saver or shuffle content periodically if fixed pattern is displayed on the screen.

2. General Description

This specification applies to 10.4 inch Color TFT LCD Module with LED backlight and 4 wires touch sensor. This module is designed for Industrial Applications. The screen format is intended to support VGA (640(H) x 480(V)) resolution and 16.2M (RGB 8-bits) or 262k colors (RGB 6-bits).

LED driving board for backlight unit is included in this module. LED unit is replaceable.

All input signals are LVDS interface compatible.

It designed with wide viewing angle; wide temperature and long life LED backlight is well suited for industrial applications.

2.1 Display Characteristics

The following items are characteristics summary on the table under 25°C condition

Items	Unit	Specifications
Screen Diagonal	[inch]	10.4
Active Area	[mm]	211.2 (H) x 158.4 (V)
Pixel H x V		640 x 3(RGB) x 480
Pixel Pitch	[mm]	0.33(H) x 0.33(V)
Pixel Arrangement		R.G.B. Vertical Stripe
Display Mode		TN, Normally White
Nominal Input Voltage VDD	[Volt]	3.3 (typ.)
Typical Power Consumption	[Watt]	5.4 W All black pattern
Weight	[Grams]	450
Physical Size	[Volt]	243.0(H) x 176.6(V) x 9.8(D)
Electrical Interface		1 channel LVDS
Surface Treatment		Anti-glare, Hardness 3H
Support Color		16.2M / 262K colors
Temperature Range		
Operating	[°C]	-5 to +60
Storage(Shipping)	[°C]	-30 to +70
RoHS Compliance		RoHS Compliance

2.2 Optical Characteristics

The optical characteristics are measured under stable conditions at 25 °C (Room Temperature)

Item	Unit	Condition	Min.	Typ.	Max.	Remark
White Luminance	[cd/m ²]	I _F = 15mA/1 LED Line (center point)	260	360	-	1
White Uniformity	%	5 Points	75	-	-	2,3
Contrast Ratio			500	700	-	4
Response Time	[msec]	Rising	-	20	30	5
	[msec]	Falling	-	10	20	
	[msec]	Raising + Falling	-	30	50	
Viewing Angle	[degree]	Horizontal (Right)	70	80	-	6
	[degree]	CR ≥ 10 (Left)	70	80		
	[degree]	Vertical (Upper)	50	60	-	
	[degree]	CR ≥ 10 (Lower)	70	80		
Color / Chromaticity Coordinates (CIE 1931)		Red x	0.504	0.554	0.604	
		Red y	0.280	0.330	0.380	
		Green x	0.284	0.334	0.384	
		Green y	0.529	0.579	0.629	
		Blue x	0.112	0.162	0.212	
		Blue y	0.092	0.142	0.192	
		White x	0.26	0.31	0.36	
		White y	0.28	0.33	0.38	
Color Gamut	%		-	45	-	

Note 1 : Measurement method

Equipment Pattern Generator, Power Supply, Digital Voltmeter, Luminance meter (SR_3 or equivalent)

Aperture 1° with 50cm viewing distance
 Test Point Center
 Environment < 1 lux

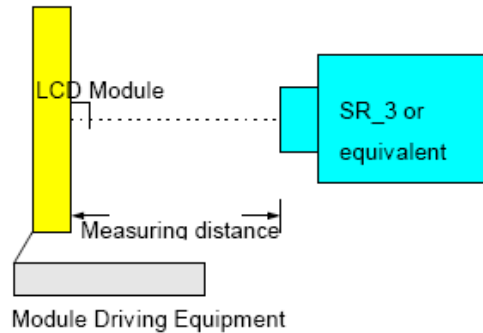

Note 2 : Definition of 5 points position (Display active area: 211.2mm (H) x 158.4mm (V))

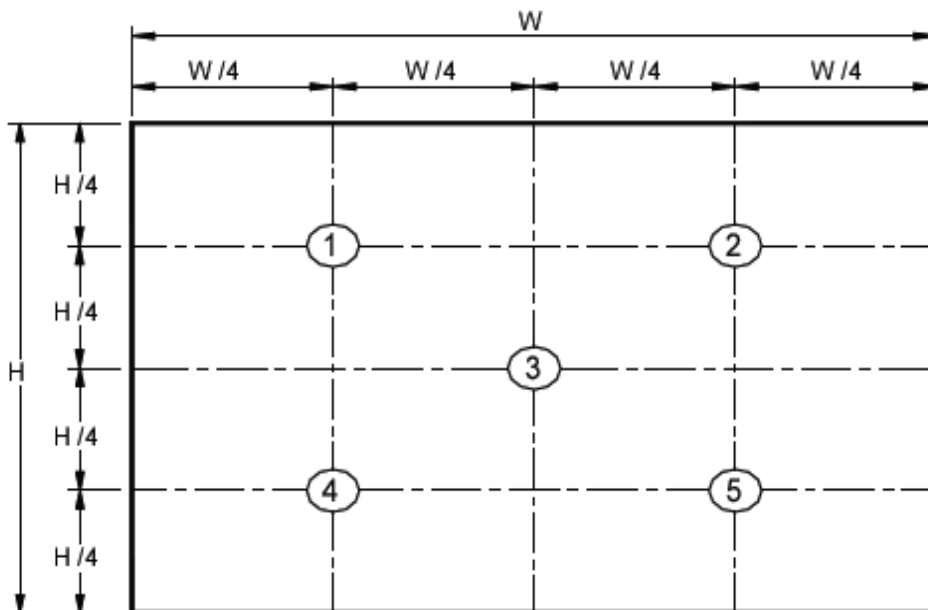

Note 3 : The luminance uniformity of 5 points is defined by dividing the maximum luminance values by the minimum test point luminance

$$\delta_{W5} = \frac{\text{Maximum Brightness of five points}}{\text{Minimum Brightness of five points}}$$

Note 4 : Definition of contrast ratio (CR):

$$\text{Contrast ratio (CR)} = \frac{\text{Brightness on the "White" state}}{\text{Brightness on the "Black" state}}$$

Note 5 : Definition of response time:

The output signals of photo detector are measured when the input signals are changed from "White" to "Black" (falling time) and from "Black" to "White" (rising time), respectively. The response time interval is between 10% and 90% of amplitudes. Please refer to the figure as below.

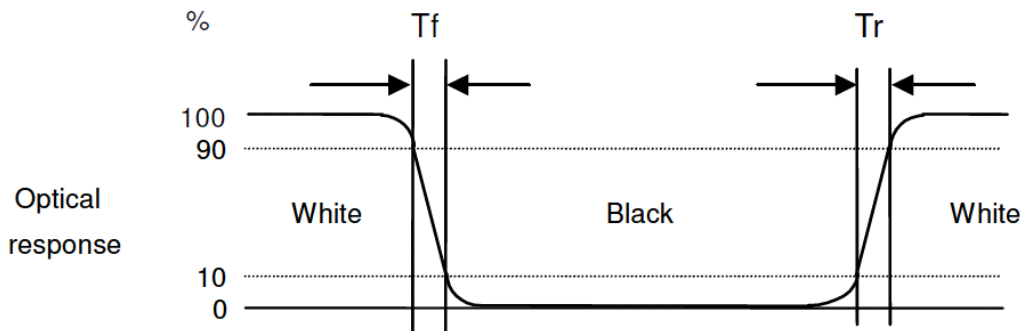

Note 6 : Definition of viewing angle

Viewing angle is the measurement of contrast ratio ≥ 10 , at the screen center, over a 180° horizontal and 180° vertical range (off-normal viewing angles). The 180° viewing angle range is broken down as below: 90° (θ) horizontal left and right, and 90° (Φ) vertical high (up) and low (down). The measurement direction is typically perpendicular to the display surface with the screen rotated to its center to develop the desired measurement viewing angle.

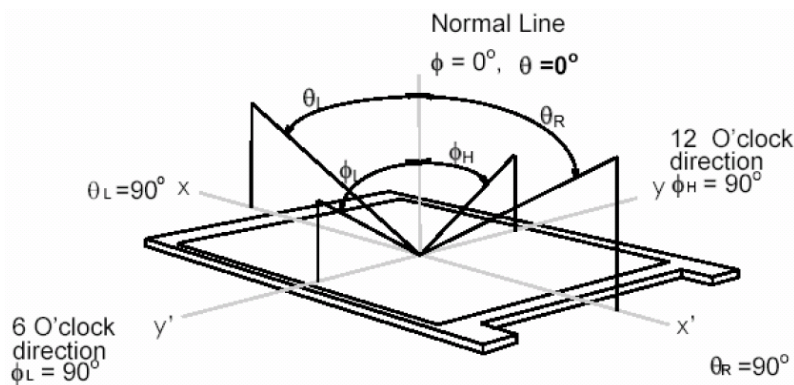

3. Functional Block Diagram

The following diagram shows the functional block of the 5.7 inch color TFT/LCD module:

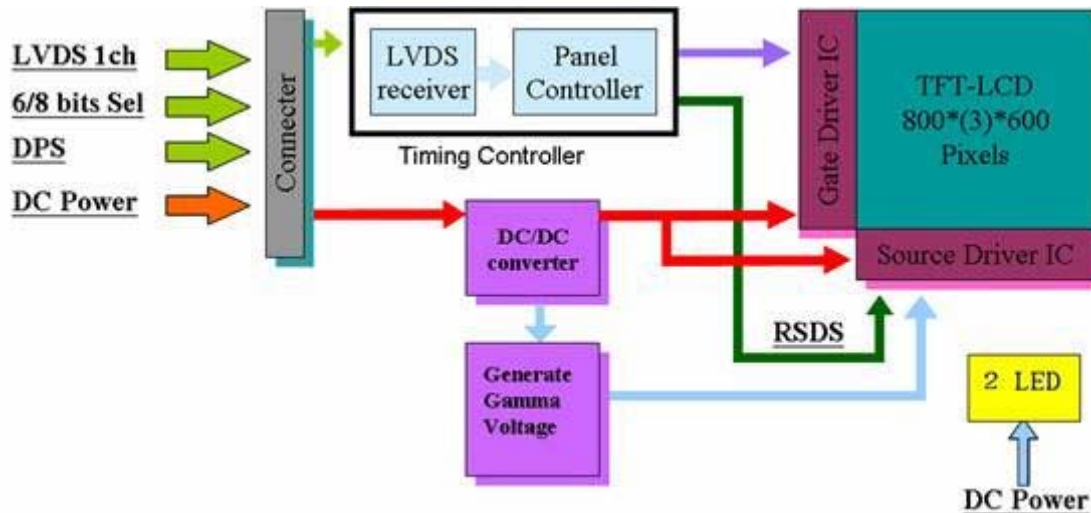

4. Absolute Maximum Ratings

4.1 Absolute Ratings of TFT LCD Module

Item	Symbol	Min	Max	Unit
Logic/LCD Drive Voltage	Vin	-0.3	+4.0	Volt

4.2 Absolute Ratings of Environment

Item	Symbol	Min	Max	Unit
Operating Temperature	TOP	-5	+60	[°C]
Operation Humidity	HOP	20	90	[%RH]
Storage Temperature	TST	-30	+70	[°C]
Storage Humidity	HST	10	90	[%RH]

Note 1: Maximum Wet-Bulb should be 39°C and no condensation.

5. Electrical Characteristics

5.1 TFT LCD Module

5.1.1 Power Specification

Symbol	Parameter	Min	Typ	Max	Units	Remark
VDD	Logic/LCD Input Voltage	3.0	3.3	3.6	[Volt]	
I _{VDD}	LCD Input Current	-	280	-	[mA]	All black pattern (VDD=3.3V, at 60Hz)
P _{VDD}	LCD Power consumption	-	0.924	-	[Watt]	All black pattern (VDD=3.3V, at 60Hz)
I _{rush LCD}	LCD Inrush Current	-	-	1.5	[A]	Note 1; VDD=3.3v Black Pattern, Rising time=470us
VDD _{rp}	Allowable Logic/LCD Drive Ripple Voltage	-	-	100	[mV] p-p	All black pattern (VDD=3.3v, at 60Hz)

Note 1 : Measurement condition:

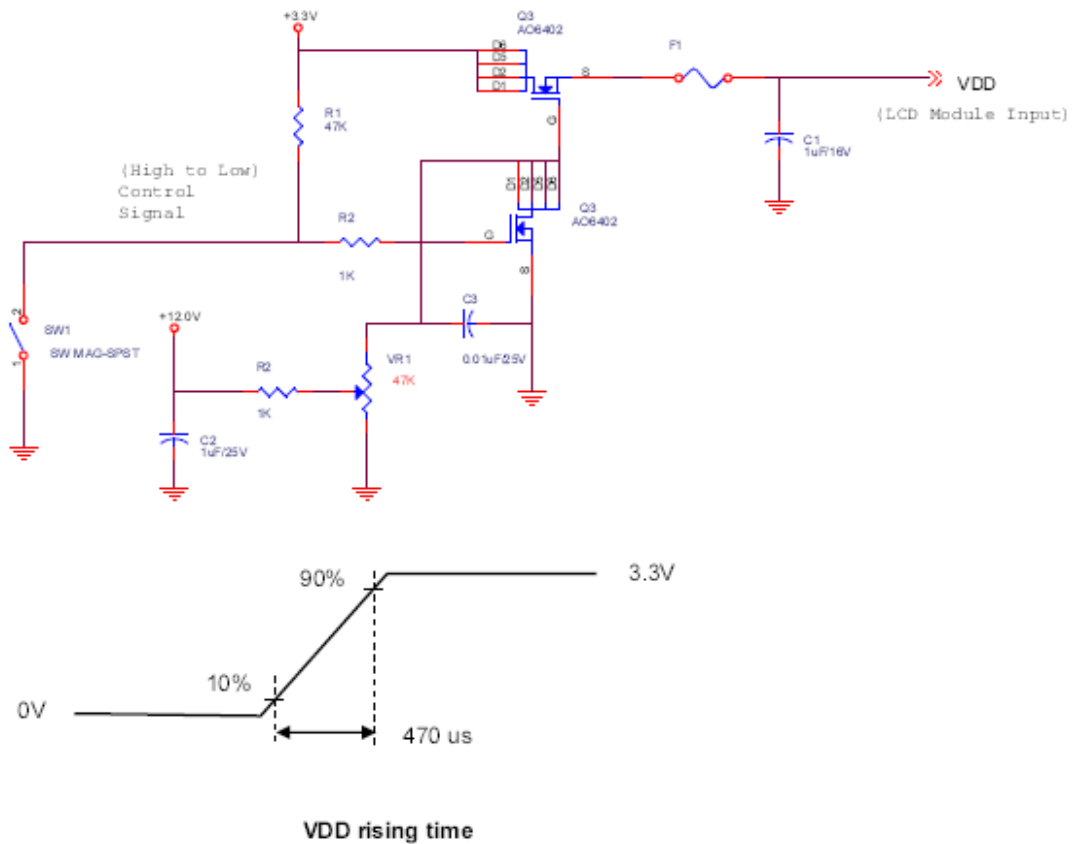

ALL RIGHTS STRICTLY RESERVED. ANY PORTION OF THIS PAPER SHALL NOT BE REPRODUCED, COPIED, OR 10
TRANSFORMED TO ANY OTHER FORMS WITHOUT PREMISSION FROM PROMATE ELECTRONIC CO., LTD.

5.1.2 Signal Electrical Characteristics

Input signals shall be low or Hi-Z state when VDD is off.

Symbol	Item	Min.	Typ.	Max.	Unit	Remark
VTH	Differential Input High Threshold	-	-	100	[mV]	VCM=1.2V
VTL	Differential Input Low Threshold	100	-	-	[mV]	VCM=1.2V
VID	Input Differential Voltage	100	400	600	[mV]	
VICM	Differential Input Common Mode Voltage	1.1	-	1.45	[V]	VTH/VTL=+-100mV

Note: LVDS Signal Waveform.

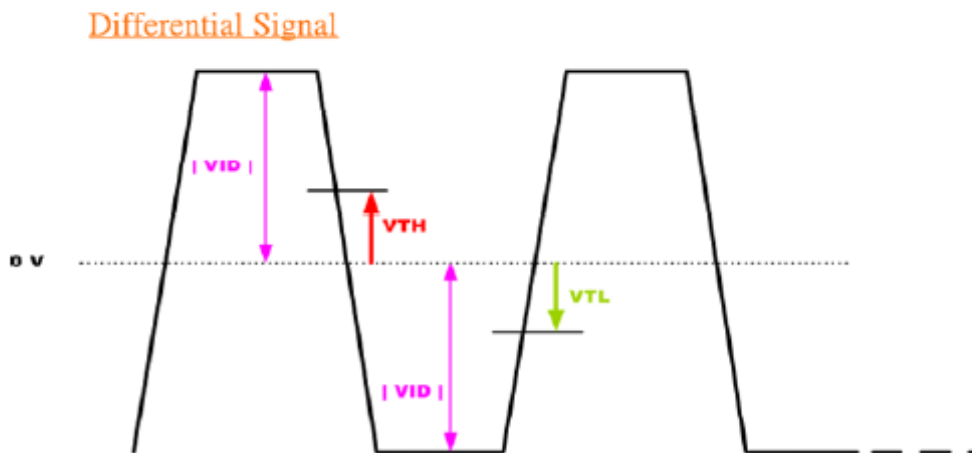
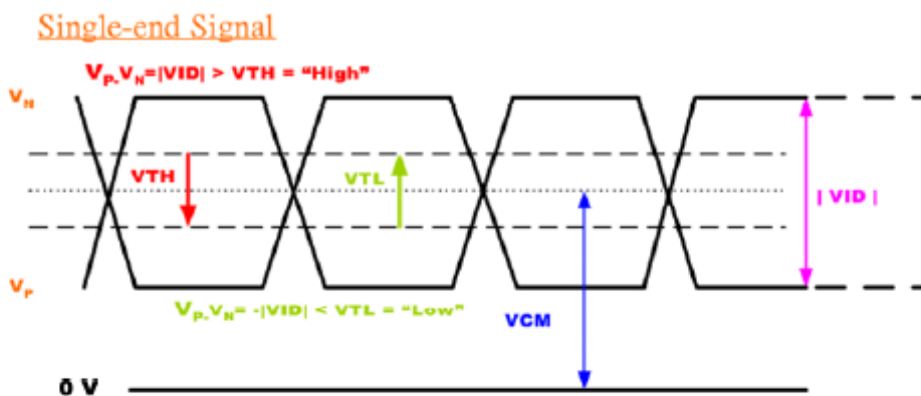

5.2 Backlight Unit

5.2.1 Parameter guideline for LCD

Following characteristics are measured under a stable condition using an inverter at 25°C (Room Temperature):

Symbol	Parameter	Min.	Typ.	Max.	Unit	Remark
VCC	Input Voltage	10.8	12	12.6	[Volt]	
I _{VCC}	Input Current	-	0.37	-	[A]	100% PWM Duty
P _{LED}	Power Consumption	-	4.44	-	[Watt]	100% PWM Duty
I _{rush LED}	Inrush Current	-	-	1.5	[A]	at rising time=470us
F _{PWM}	Dimming Frequency	200	-	20K	[Hz]	
	Swing Voltage	3	3.3	5.5	[Volt]	
	Dimmung duty cycle	5	-	100	%	
I _F	LED Forward Current	-	80	-	[mA]	Ta = 25°C
V _F	LED Forward Voltage	-	28	-	[Volt]	I _F = 80mA, Ta = -30°C
		-	25.5	29.2	[Volt]	I _F = 80mA, Ta = 25°C
		-	24.8	-	[Volt]	I _F = 80mA, Ta = 85°C
P _{LED}	LED Power Consumption	-	4.1	-	[Watt]	
Operation Life		50,000	-	-	Hrs	I _F =80mA, Ta= 25°C

Note 1: Ta means ambient temperature of TFT-LCD module.

Note 2: VCC, I_{VCC}, I_{rush LED}, P_{VCC} are defined for LED backlight.(100% duty of PWM dimming)

Note 3: I_F, V_F are defined for one channel LED. There are two LED channel in back light unit.

Note 4: If module is driven by high current or at high ambient temperature & humidity condition. The operating life will be reduced.

Note 5: Operating life means brightness goes down to 50% initial brightness. Minimum operating estimated data

6. Signal Characteristics

6.1 Pixel Format Image

Following figure shows the relationship between input signal and LCD pixel format.

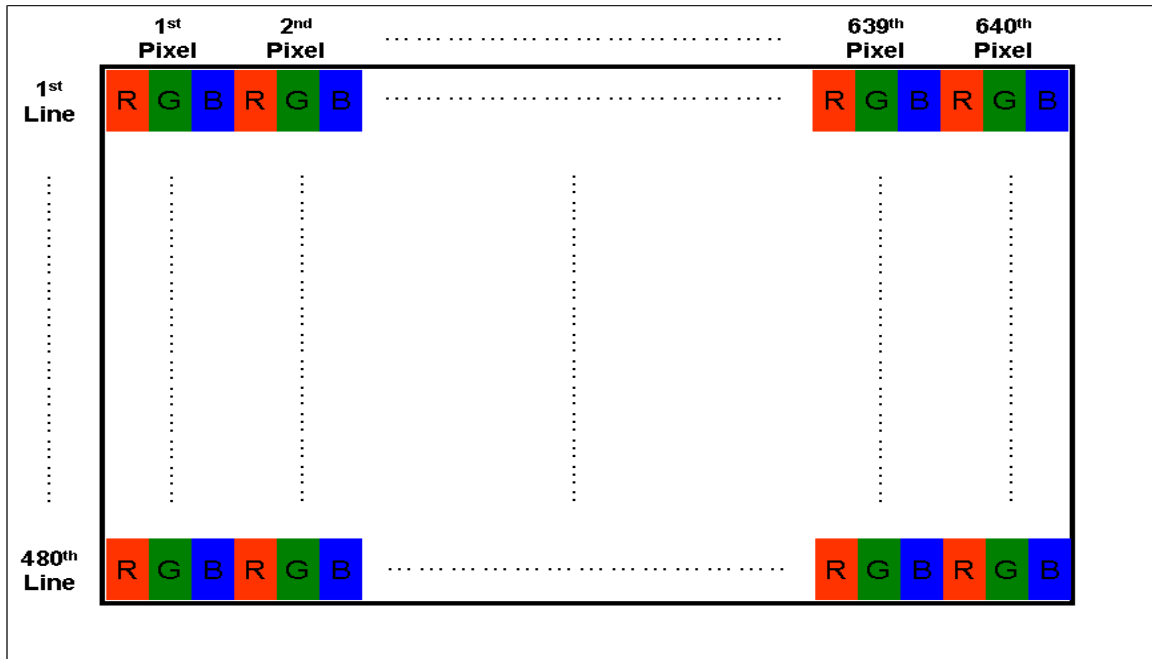

6.2 Scanning Direction

The following figures show the image seen from the front view. The arrow indicates the direction of scan.

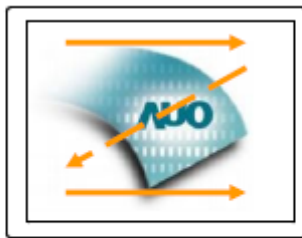

Fig. 1 Normal scan (Pin4, DPS = Low or NC)



Fig. 2 Reverse scan (Pin4, DPS = High)

6.3 The Input Data Format

SEL68="LOW" or "NC" for 6 bits LVDS Input

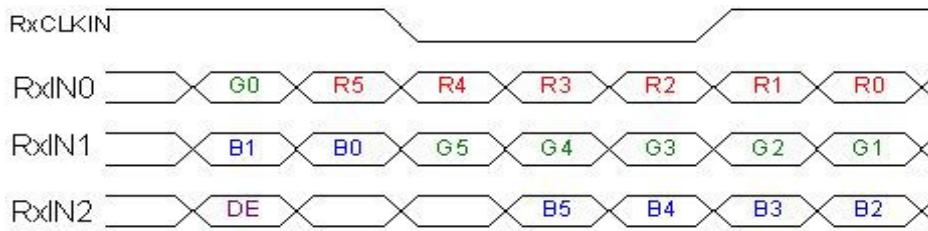

SEL68="High" for 8 bits LVDS input

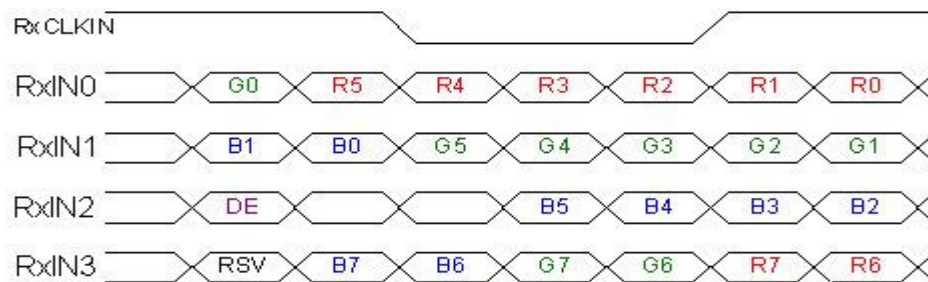

Note 1: Please follow PSWG

Note 2: R/G/B data 7:MSB, R/G/B data 0:LSB

Signal Name	Description	Remark
R7	Red Data 7	Red-pixel Data
R6	Red Data 6	
R5	Red Data 5	
R4	Red Data 4	
R3	Red Data 3	
R2	Red Data 2	
R1	Red Data 1	
R0	Red Data 0	For 8Bits LVDS input MSB: R7 ; LSB: R0
G7	Green Data 7	Green-pixel Data
G6	Green Data 6	
G5	Green Data 5	
G4	Green Data 4	
G3	Green Data 3	
G2	Green Data 2	
G1	Green Data 1	
G0	Green Data 0	For 6Bits LVDS input MSB: G5 ; LSB: G0
B7	Blue Data 7	Blue-pixel Data
B6	Blue Data 6	
B5	Blue Data 5	
B4	Blue Data 4	
B3	Blue Data 3	
B2	Blue Data 2	
B1	Blue Data 1	
B0	Blue Data 0	For 6Bits LVDS input MSB: B5 ; LSB: B0
RxCLKIN	LVDS Data Clock	
DE	Data Enable Signal	When the signal is high, the pixel data shall be valid to be displayed.

Note: Output signals from any system shall be low or Hi-Z state when VDD is off.

ALL RIGHTS STRICTLY RESERVED. ANY PORTION OF THIS PAPER SHALL NOT BE REPRODUCED, COPIED, OR TRANSFORMED TO ANY OTHER FORMS WITHOUT PREMISSION FROM PROMATE ELECTRONIC CO., LTD. 14

6.4 TFT-LCD Interface Signal Description

This module using a LVDS receiver embedded in AUO' ASIC. LVDS is a differential signal technology for LCD interface and a high-speed data transfer device.

Input Signal Interface		
Pin No.	Symbol	Description
1	VDD	Power Supply, 3.3V (typical)
2	VDD	Power Supply, 3.3V (typical)
3	GND	Ground
4	DPS	Reverse Scan Function [H: Enable; L/NC: Disable]
5	RxIN0-	LVDS receiver signal channel 0
6	RxIN0+	LVDS Differential Data Input (R0, R1, R2, R3, R4, R5, G0)
7	GND	Ground
8	RxIN1-	LVDS receiver signal channel 1
9	RxIN1+	LVDS Differential Data Input (G1, G2, G3, G4, G5, B0, B1)
10	GND	Ground
11	RxIN2-	LVDS receiver signal channel 2
12	RxIN2+	LVDS Differential Data Input (B2, B3, B4, B5, HS, VS, DE)
13	GND	Ground
14	RxCLKIN-	LVDS receiver signal clock
15	RxCLKIN+	
16	GND	Ground
17	RxIN3-	LVDS receiver signal channel 3, NC for 6 bit LVDS Input
18	RxIN3+	LVDS Differential Data Input (R6, R7, G6, G7, B6, B7, RSV)
19	RSV	Reserved for AUO internal test. Please treat it as NC.
20	SEL68	6/ 8bits LVDS data input selection [H: 8bits L/NC: 6bit]

Note 1: Input signals shall be in low status when VDD is off.

Note 2: High stands for "3.3V", Low stands for "0V", NC stands for "No Connection".

Note 3: RSV stands for "Reserved".

6.5 TFT-LCD Interface Timing

6.5.1 Timing Characteristics

Signal		Symbol	Min.	Typ.	Max.	Unit
Clock Frequency		$1/T_{\text{Clock}}$	20	25.2	28.33	MHz
Vertical Section	Period	T_V	520	525	560	TLine
	Active	T_{VD}	-	480	-	
	Blanking	T_{VB}	40	45	80	
Horizontal Section	Period	T_H	770	800	900	T_{Clock}
	Active	T_{HD}	-	640	-	
	Blanking	T_{HB}	130	160	260	

Note 1: Frame rate is 60Hz.

Note 2: DE mode.

6.5.2 Input Timing Diagram

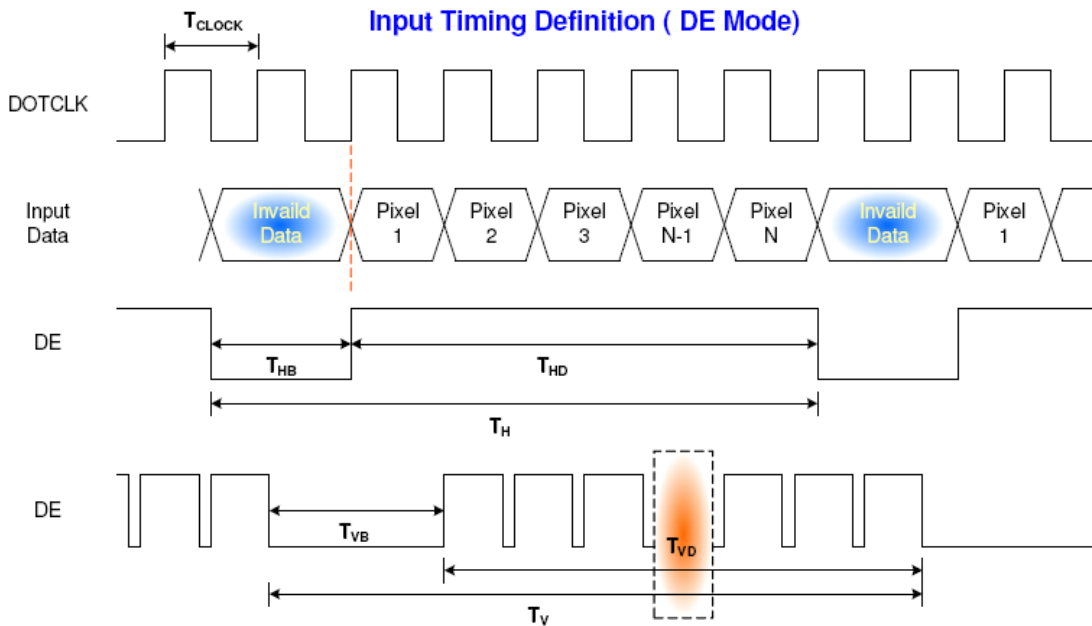

ALL RIGHTS STRICTLY RESERVED. ANY PORTION OF THIS PAPER SHALL NOT BE REPRODUCED, COPIED, OR TRANSFORMED TO ANY OTHER FORMS WITHOUT PERMISSION FROM PROMATE ELECTRONIC CO., LTD. 16

6.6 Power ON/OFF Sequence

VDD power, LCD interface signals and backlight on/off sequence are shown in the following chart. Signals from any system shall be Hi-Z state or low level when VDD is off.

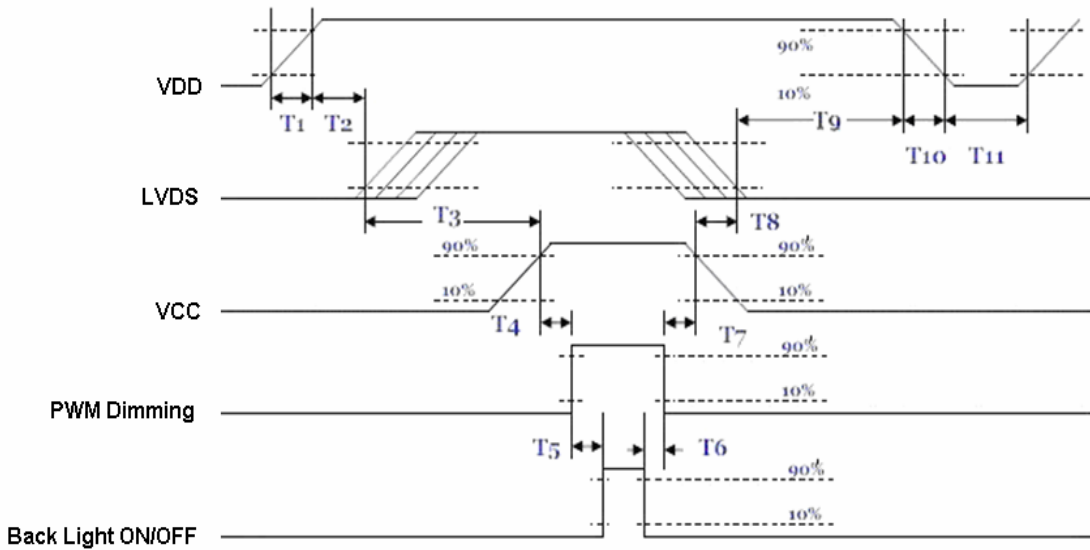

Power ON/OFF sequence timing

Parameter	Value			Units
	Min.	Typ.	Max.	
T1	0.5	-	10	[ms]
T2	30	40	50	[ms]
T3	200	-	-	[ms]
T4	10	-	-	[ms]
T5	10	-	-	[ms]
T6	0	-	-	[ms]
T7	10	-	-	[ms]
T8	100	-	-	[ms]
T9	0	16	50	[ms]
T10	-	-	10	[ms]
T11	1000	-	-	[ms]

The above on/off sequence should be applied to avoid abnormal function in the display. Please make sure to turn off the power when you plug the cable into the input connector or pull the cable out of the connector.

7. Connector & Pin Assignment

7.1 TFT LCD Signal (CN1): LCD Connector

Connector Name / Designation	Signal Connector
Manufacturer	STM or compatible
Connector Model Number	MSB24013P20HA or compatible
Adaptable Plug	P24013P20 or compatible

Pin No.	Symbol	Pin No.	Symbol
1	VDD	2	VDD
3	GND	4	DPS
5	RxIN0-	6	RxIN0+
7	GND	8	RxIN1-
9	RxIN1+	10	GND
11	RxIN2-	12	RxIN2+
13	GND	14	RxCKIN-
15	RxCKIN+	16	GND
17	RxIN3-	18	RxIN3+
19	RSV	20	SEL68

7.2 LED Backlight Unit (CN2): Backlight Connector

Connector Name / Designation	Lamp Connector
Manufacturer	ENTERY or compatible
Connector Model Number	3808K-F05N-02R or compatible
Mating Model Number	H208K-P05N-02B or compatible

Pin No.	symbol	description
Pin1	VCC	12V input
Pin2	GND	GND
Pin3	On/OFF	5V-ON,0V-OFF
Pin4	Dimming	PWM
Pin5	NA	

7.3 LED Backlight Unit (CN4): Light bar Connector

Connector Name / Designation	Lamp Connector
Manufacturer	ENTERY or compatible
Connector Model Number	H208K-P03N-02B or compatible
Mating Model Number	3808K-F03N-02R or compatible

Pin No.	symbol	description	Color
Pin1	H	LED anode	Red
Pin2	L	LED cathode	White
Pin3	L	LED cathode	Black

ALL RIGHTS STRICTLY RESERVED. ANY PORTION OF THIS PAPER SHALL NOT BE REPRODUCED, COPIED, OR TRANSFORMED TO ANY OTHER FORMS WITHOUT PERMISSION FROM PROMATE ELECTRONIC CO., LTD. 18

8. Touch Panel Specification

8.1 Operating condition

Item	Min.	Typ.	Max.	Unit	Remark
Operating voltage	-	-	7	V _{DC}	

8.2 Electrical characteristic

Item		Min.	Typ.	Max.	Unit	Remark
Resistance between terminal	XL-XR	200	-	1000	Ω	
	YU-YD	100	-	800	Ω	
Insulation resistance	X-Y	10	-	-	MΩ	DC 25V
Linearity	X	-	-	2	%	
	Y	-	-	3.5	%	

8.3 Mechanical characteristic

Item	Min.	Typ.	Max.	Unit	Remark
Pen/Finger input pressure	-	-	80	gf	Finger, Pen
Surface hardness	-	3		H	

9. Reliability Test Criteria

Test item	Test condition	Remark
High temperature storage	70°C, 8Hrs	
Low temperature storage	-30°C, 8Hrs	
High temperature operation	60°C, 8Hrs	
Low temperature operation	-5°C, 8Hrs	

10. Display Quality

The display quality of the color TFT-LCD module should be in compliance with the Promate's OQC inspection standard.

11. Mechanical Characteristics

11.1 LCM Outline Dimension (Front View)

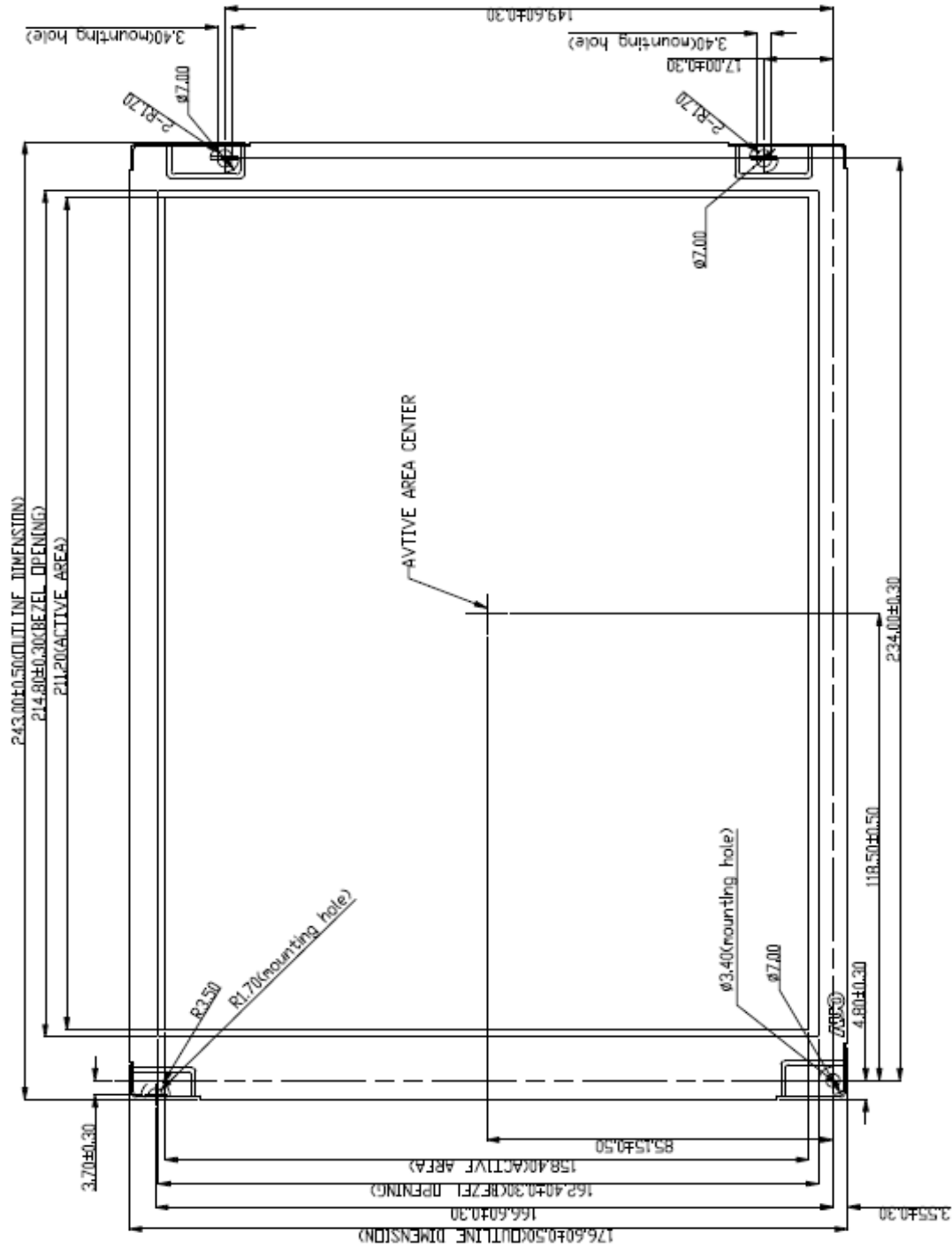

ALL RIGHTS STRICTLY RESERVED. ANY PORTION OF THIS PAPER SHALL NOT BE REPRODUCED, COPIED, OR 21 TRANSFORMED TO ANY OTHER FORMS WITHOUT PREMISSION FROM PROMATE ELECTRONIC CO., LTD.

11.2 LCM Outline Dimension (Rear View)

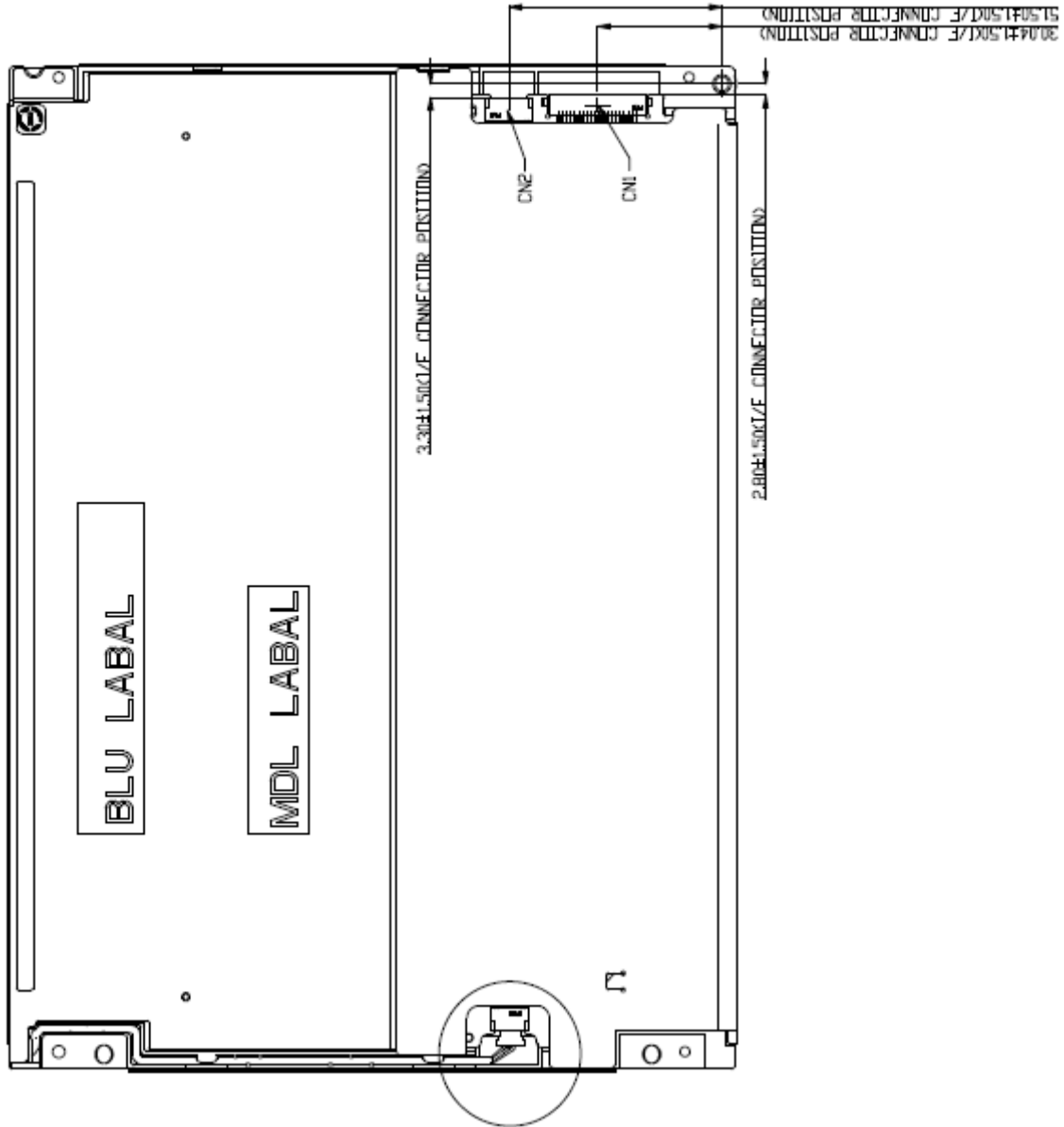

ALL RIGHTS STRICTLY RESERVED. ANY PORTION OF THIS PAPER SHALL NOT BE REPRODUCED, COPIED, OR 22
TRANSFORMED TO ANY OTHER FORMS WITHOUT PREMISSION FROM PROMATE ELECTRONIC CO., LTD.

11.3 Touch Sensor Outline Dimension

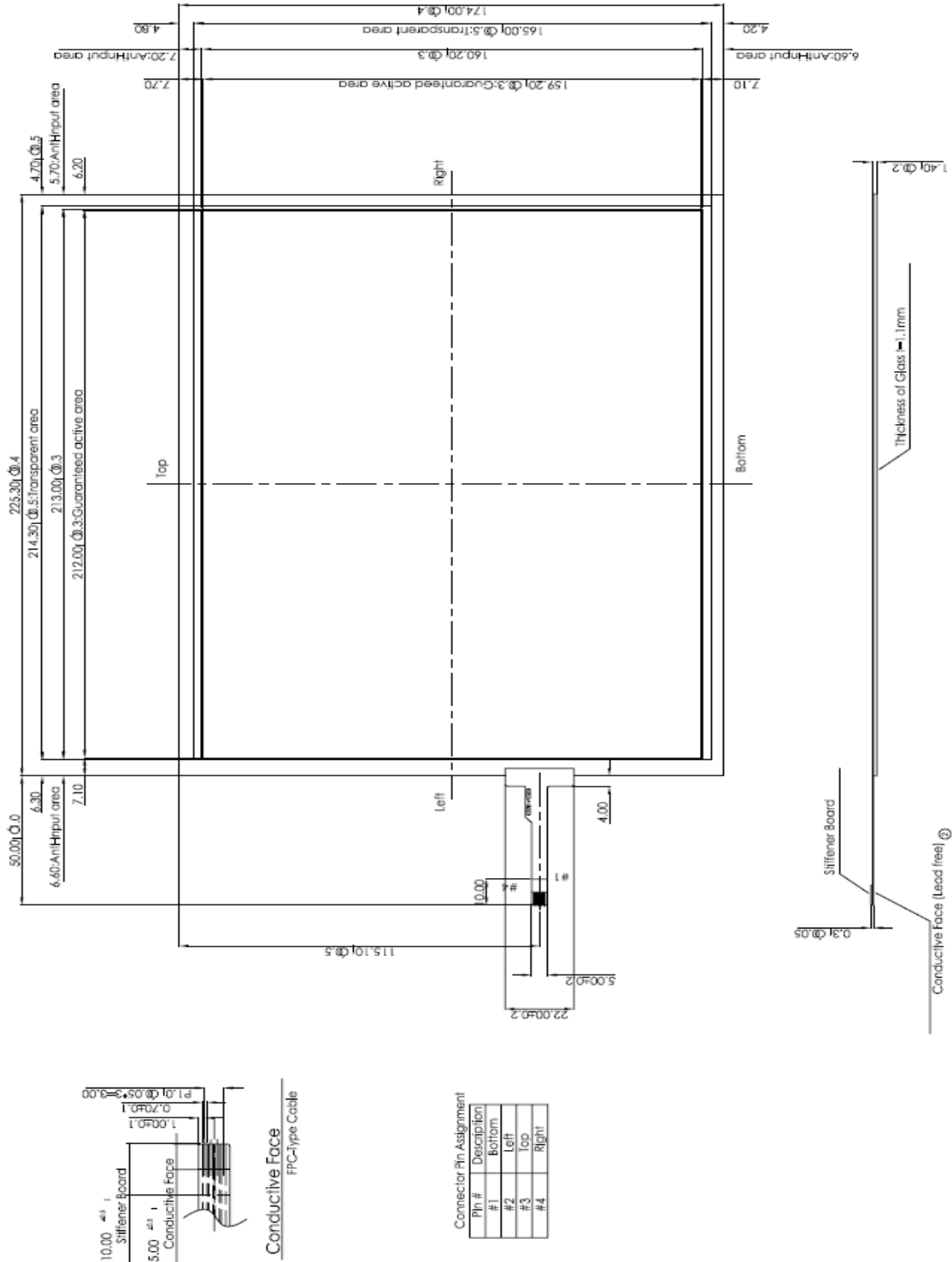

ALL RIGHTS STRICTLY RESERVED. ANY PORTION OF THIS PAPER SHALL NOT BE REPRODUCED, COPIED, OR TRANSFORMED TO ANY OTHER FORMS WITHOUT PERMISSION FROM PROMATE ELECTRONIC CO., LTD. 23

TERMS AND CONDITIONS OF SALE

These Terms and Conditions of Sale apply to all items designed and/or made by Promate Electronics Company, LTD ("Promate"), and Buyer agrees they apply to all such items, unless a separate Agreement of Terms and Conditions has been mutually agreed upon and signed by both parties, at which time, the Separate Signed Terms and Conditions will supersede all terms and conditions listed hereof.

1 ACCEPTANCE OF TERMS. BUYER ACCEPTS THESE TERMS (i) BY WRITTEN ACCEPTANCE (BY PURCHASE ORDER OR OTHERWISE), OR (ii) BY FAILURE TO RETURN GOODS SUPPLIED BY PROMATE WITHIN 5 DAYS OF THEIR DELIVERY.

2 DELIVERY

2.1 Delivery will be made Free Carrier (Incoterms 1990), Promate's designated warehouse to a carrier designated in writing by Buyer, or if Buyer fails to designate a carrier, to a carrier designated by Promate.

2.2 Title to the goods and the entire risk will pass to Buyer upon delivery to carrier.

2.3 Shipments are subject to availability. Promate shall make every reasonable effort to meet the date(s) quoted or acknowledged; and if Promate makes such effort, PROMATE WILL NOT BE LIABLE FOR ANY DELAYS.

3 TERMS OF PAYMENT

3.1 Unless otherwise stated on Promate's quotation, all shipments shall be T/T in advance, by Letter of Credit at Sight, or pursuant to agreed prepayment terms. Promate reserves the right to change credit terms at any time in its sole discretion.

3.2 Buyer guarantees prompt payment of all obligations accrued pursuant to purchase orders issued by Buyer.

4 LIMITED WARRANTY

4.1 Promate warrants that the goods sold will be free from defects in material and workmanship and comply with Promate's applicable published specifications for a period of twelve (12) months from the date of Promate's shipment.

4.2 Goods or parts which have been subject to abuse (including without limitation repeated or extended exposure to conditions at or near the limits of applicable absolute ratings) misuse, accident, alteration, neglect, or unauthorized repair or improper application are not covered by any warranty. No warranty is made with respect to custom products or goods produced to Buyer's specifications (unless specifically stated in writing signed by Promate). Promate shall not be responsible for defects or claims caused by acts not performed by Promate; or by combination of goods with other things.

4.3 No warranty is made with respect to goods used in devices intended for use in applications where failure to perform when properly used can reasonably be expected to result in significant injury (including, without limitation, navigation, aviation, weaponry or nuclear equipment, or for surgical implant or to support or sustain life) and Buyer agrees to indemnify, defend, and hold harmless Promate from all claims, damages and liabilities arising out of any such uses.

4.4 This Article 4 is the only warranty by Promate with respect to goods and may not be modified or amended except in writing signed by an authorized officer of Promate.

4.5 Buyer acknowledges and agrees that it is not relying on any literature, diagrams or circuits contained in any literature, and Buyer will test all parts and applications under extended field and laboratory conditions. Notwithstanding any cross-reference or any statements of compatibility, functionality, interchangeability, and the like, the goods may differ from similar goods from other vendors in performance, function or operation, and in areas not contained in the written specifications, or as to ranges and conditions outside such specifications; and Buyer agrees that there are no warranties and that Promate is not responsible for such things.

4.6 REGARDLESS OF CAUSE OR REASON FOR DAMAGE (WHETHER ACCIDENT, NEGLIGENCE, OR OTHERWISE) PROMATE SHALL HAVE NO LIABILITY (DIRECT, CONSEQUENTIAL OR OTHER) FOR, IN CONNECTION WITH OR ARISING FROM PROPERTY FURNISHED FOR USE AT OR LEFT AT PROMATE; and by delivering or entrusting property to Promate, Buyer expressly confirms this limitation. Notwithstanding this limitation, Promate will replace, or pay the reasonable retooling costs to replace, masks damaged or destroyed as a result of Promate's gross negligence or fault.

4.7 EXCEPT AS PROVIDED ABOVE, PROMATE MAKES NO WARRANTIES OR CONDITIONS, EXPRESS, IMPLIED, OR STATUTORY, AND PROMATE EXPRESSLY EXCLUDES AND DISCLAIMS ANY WARRANTY OR CONDITION OF NON-INFRINGEMENT, MERCHANTABILITY OR FITNESS FOR PARTICULAR PURPOSE OR APPLICATION.

5 LIMITATION OF LIABILITY

5.1 Promate will not be liable for any loss, damage or penalty resulting from causes beyond its reasonable control, including but not limited to delay by others, force majeure, acts of God, material shortage or labor conditions. In any such event, the date(s) for Promate's performance will be deemed extended for a period equal to any delay resulting.

5.2 THE LIABILITY OF PROMATE ARISING OUT OF THIS AGREEMENT OR ANY GOODS SOLD WILL BE LIMITED TO REFUND OF THE PURCHASE PRICE OR (WITH PROMATE'S PRIOR WRITTEN CONSENT) REPAIR OR REPLACEMENT OF PURCHASED GOODS (RETURNED TO PROMATE FREIGHT PRE-PAID) OR IN THE EVENT OF A FAILURE OR BREACH BY PROMATE REGARDING DELIVERY, AN AMOUNT EQUAL TO THE TOTAL PURCHASE PRICE OF THE GOODS THAT HAVE NOT BEEN DELIVERED DUE TO SUCH FAILURE.

5.3 Buyer will not return any goods without first obtaining a customer return order number.

5.4 AS A SEPARATE LIMITATION, IN NO EVENT WILL PROMATE BE LIABLE (i) FOR COSTS OF SUBSTITUTE GOODS, (ii) FOR ANY SPECIAL, CONSEQUENTIAL, INCIDENTAL, RELIANCE OR INDIRECT DAMAGES, OR (iii) FOR LOSS OF USE, OPPORTUNITY, MARKET POTENTIAL, GOODWILL AND/OR PROFIT ON ANY THEORY (CONTRACT, TORT, FROM THIRD PARTY CLAIMS OR OTHERWISE). THESE LIMITATIONS SHALL APPLY NOTWITHSTANDING ANY FAILURE OF ESSENTIAL PURPOSE OR OF ANY FAILURE OR INADEQUACY OF ANY REMEDY. THIS AGREEMENT STATES THE ONLY AND EXCLUSIVE REMEDY FOR ANY AND ALL CLAIMS MADE AGAINST PROMATE UNDER ANY AGREEMENT AND/OR WITH RESPECT TO PANELS, COMPONENTS, SERVICES AND/OR GOODS.

5.5 No action or proceeding may be commenced by either party against the other (other than to collect money due for goods delivered or services rendered), whether for breach, indemnification, contribution or otherwise, more than one year after delivery of the goods to the carrier; and no claim may be brought unless the non-claiming party has first been given commercially reasonable notice, a full written explanation of all pertinent details (including copies of all materials), and a good faith opportunity to resolve the matter.

5.6 BUYER EXPRESSLY AGREES TO THE LIMITATIONS OF ARTICLES 5, 8 AND 9 AND TO THEIR REASONABLENESS.

5.7 The exclusions and limitations of Articles 5, 8 and 9 will survive the termination of the applicable Agreements, and shall apply notwithstanding any claim of a failure of any one or more remedies to accomplish their purpose, and THE PARTIES EXPRESSLY WAIVE AND RELINQUISH ANY CONTRARY RIGHTS UNDER ANY AGREEMENT, AND/OR LAW, DECISION, CUSTOM OR PRACTICE.

6 SUBSTITUTIONS AND MODIFICATIONS

Promate may at any time make substitutions for product ordered which do not materially and adversely affect overall performance with the then current specifications in the typical and intended use. Promate reserves the right to halt deliveries and shipments and alter specifications and prices without notice. Buyer shall verify that the literature and information is current before purchasing. Other changes to process and/or specifications by Promate shall be pursuant to Promate's standard ECN procedures.

7 CANCELLATION

7.1 This Agreement may not be canceled by Buyer except with written consent by Promate and Buyer's payment of reasonable cancellation charges (including but not limited to expenses already incurred for labor and material, overhead, commitments made by Promate, and a reasonable profit).

7.2 In no event will Buyer have rights in partially completed goods.

8 INDEMNIFICATION

8.1 Promate will, at its own expense, assist Buyer with technical support and information in connection with any claim that any parts as shipped by Promate under this purchase order infringe any valid, enforceable, unexpired R.O.C. patent, copyright, or trademark, provided however, that Buyer (i) gives immediate written notice to Promate, (ii) permits Promate to participate and to defend if Promate requests to do so, and (iii) gives Promate all needed information, assistance and authority. However, Promate will not be responsible for infringements resulting from anything not entirely manufactured by Promate, or from any combination with products, equipment, or materials not furnished by Promate. Promate will have no liability with respect to intellectual property matters arising out of products made to Buyer's specifications, code, or designs.

8.2 Except as expressly stated in this Article 8 or in another writing signed by an authorized officer, Promate makes no representations and/or warranties with respect to intellectual and/or industrial property and/or with respect to claims of infringement.

8.3 Except as to claims Promate agrees in writing to defend, BUYER WILL INDEMNIFY, DEFEND AND HOLD HARMLESS PROMATE FROM ALL CLAIMS, COSTS, LOSSES, AND DAMAGES (INCLUDING ATTORNEYS FEES) AGAINST AND/OR ARISING OUT OF GOODS SOLD AND/OR SHIPPED HEREUNDER.

9 NO CONFIDENTIAL INFORMATION

Promate shall have no obligation to hold any information in confidence except as provided in a separate non-disclosure agreement signed by both parties.

10 ENTIRE AGREEMENT

These terms and conditions are the entire agreement between Promate and Buyer, and no addition, deletion or modification shall be binding on Promate unless expressly agreed to in a writing signed by an officer of Promate. Buyer is not relying upon any warranty or representation except for those specifically stated here.

11 APPLICABLE LAW

This Agreement and all performance and disputes arising out of or relating to goods involved will be governed by the laws of Taiwan, Republic of China, without reference to conflict of laws principles and excluding the U.N. Convention on Contracts for the International Sale of Goods. Buyer agrees at its sole expense to comply with all applicable laws in connection with the purchase, use or sale of the goods provided hereunder.

12 DISPUTE RESOLUTION

12.1 Buyer and Promate shall cooperate and attempt in good faith to resolve any and all disputes arising out of and/or relating to this Agreement and/or goods furnished pursuant to this Agreement.

12.2 Any disputes relating to and/or arising out of any Agreement and/or goods furnished pursuant to this Agreement that cannot be so resolved will be decided exclusively by binding arbitration. Such arbitration shall take place in Taipei, Taiwan pursuant to the Rules for International Arbitration under the American Arbitration Association.

12.3 Notwithstanding anything to the contrary, any party may apply to any court of competent jurisdiction for interim injunctive relief with respect to irreparable harm which cannot be avoided and/or compensated by such arbitration proceedings, without breach of this Article 12 and without any abridgment of the powers of the arbitrators.

13 ATTORNEYS' FEES

Reasonable attorneys' fees and costs will be awarded to the prevailing party in the event of litigation involving the enforcement or interpretation of this Agreement.

ALL RIGHTS STRICTLY RESERVED. ANY PORTION OF THIS PAPER SHALL NOT BE REPRODUCED, COPIED, OR TRANSFORMED TO ANY OTHER FORMS WITHOUT PERMISSION FROM PROMATE ELECTRONIC CO., LTD.

**Promate Electronic Co., Ltd. | TEL: +886 (2) 2659 0303 | FAX: +886 (2) 2658 0954 | www.promate.com
4F, No. 32, Section 1, Huan Shan Road., Nei Hu District, Taipei 11442, Taiwan**