

FEATURES

- 400 - 450
- 1.0 dB Hysteresis
- Input / Output Operating Range ± 10 dB
- Surface Mount Package



**MODEL NO.
DTD05080**

Threshold Detector

TD

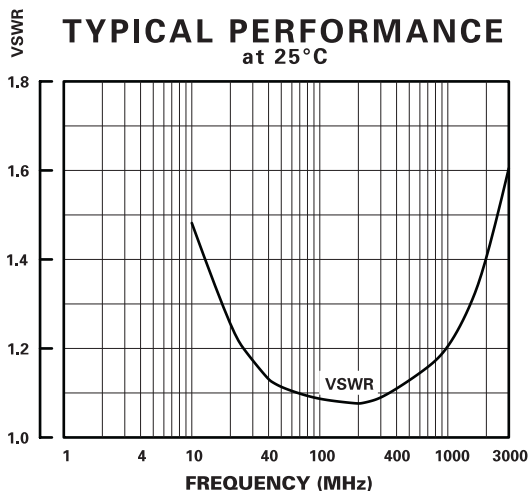
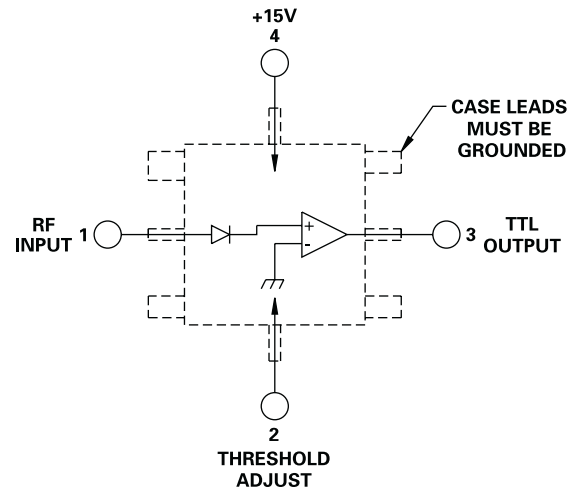
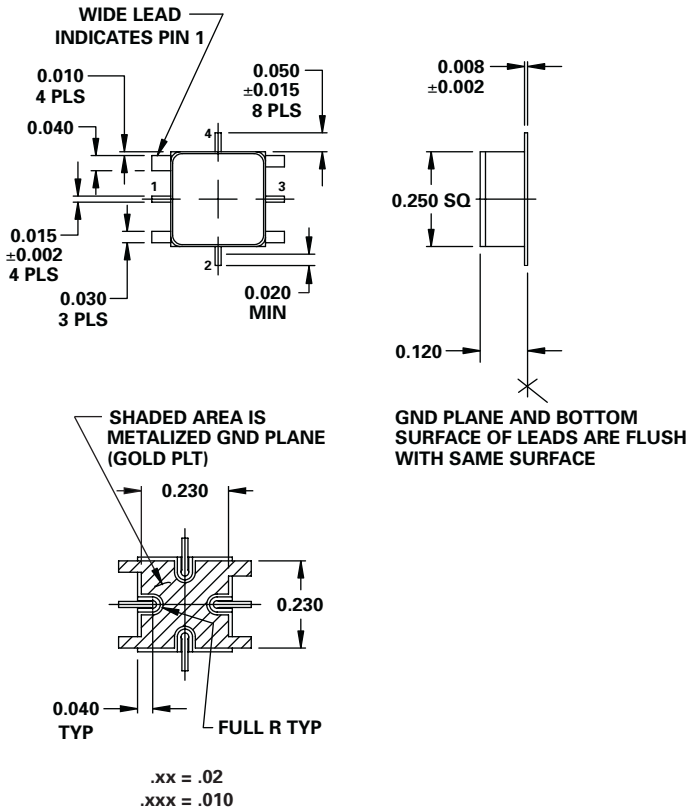

GUARANTEED PERFORMANCE

Parameter	Min	Typ	Max	Units	Conditions
Operating Frequency	400		450	MHz	
Dynamic Range	-10		+10	dBm	
Hysteresis		1.0	1.2	dB	
Temperature Stability		± 15	± 05	dB	
Input Flatness		± 35	± 05	dB	
Transition Time		2.3	3	μ Sec	90% / 10% or 10% / 90% RF
Input VSWR		1.12/1	1.5/1		
Output Current	Source	3	8.6	mA	Output Short Circuit Current VOL = +0.7 V
	Sink	2	24	mA	
DC Current		11	15	mA	+15 V
Operating Temperature	0	+25	+60	°C	TA