

Technical Data

DV74ACT00 Available Q2, 1995

Quad 2-Input NAND Gate

This device contains four independent gates, each of which performs the logic NAND function.

- Advanced very high speed CMOS
- Outputs source/sink 24 mA
- Transmission line driving 50 ohms
- ACT has TTL compatible inputs
- AC device operation guaranteed from 2 to 6 volts
- DC & AC Parameters guaranteed over -40 to +85°C

DV74AC00
DV74ACT00

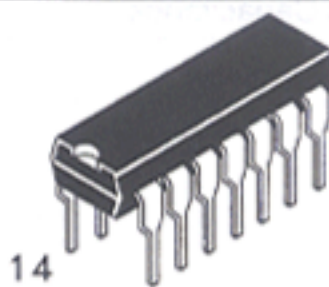

N Suffix
Plastic DIP
AVG-001 Case

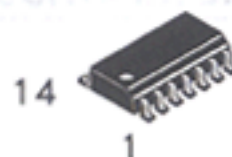

D Suffix
Plastic DIP
AVG-002 Case

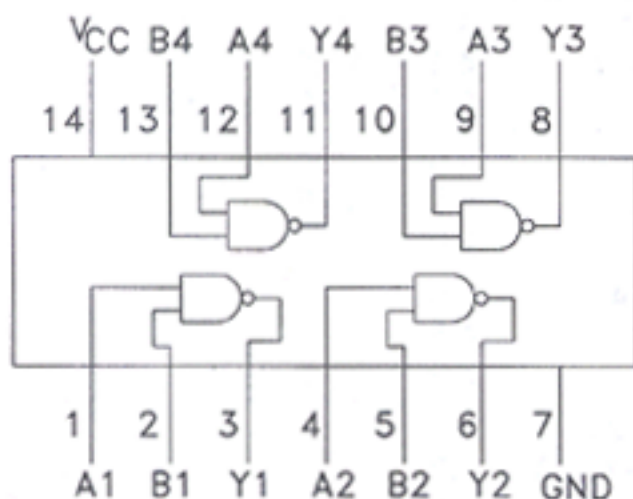

TRUTH TABLE
 $Y = \overline{AB}$

Inputs		Outputs
A	B	Y
L	L	H
L	H	H
H	L	H
H	H	L

H=High Logic Level
L=Low Logic Level
X=Don't care

ABSOLUTE MAXIMUM RATINGS

Maximum ratings are those values beyond which damage to the device may occur.

Symbol	Parameter	AC00, ACT00	Unit
V _{CC}	DC Supply Voltage (Referenced to GND)	- 0.5 to +7.0	V
V _{IN}	DC Input Voltage (Referenced to GND)	- 0.5 to V _{CC} +0.5	V
V _{OUT}	DC Output Voltage (Referenced to GND)	- 0.5 to V _{CC} +0.5	V
I _{IN}	DC Input Current, per Pin	± 20	mA
I _{OUT}	DC Output Sink/Source Current, per Pin	± 50	mA
I _{CC}	DC V _{CC} or GND Current per Output Pin	± 50	mA
T _{stg}	Storage Temperature	- 65 to +150	°C

GUARANTEED OPERATING CONDITIONS

Symbol	Parameter	Min	Typ	Max	Unit	
V _{CC}	Supply Voltage	'AC	2.0	5.0	6.0	V
		'ACT	4.5	5.0	5.5	
V _{IN} , V _{OUT}	DC Input Voltage, Output Voltage, (Ref. to GND)	0		V _{CC}	V	
t _r , t _f	Input Rise and Fall Time (Note 1) AC Devices	V _{CC} @ 3.0 V		150	ns/V	
		V _{CC} @ 4.5 V		40	ns/V	
		V _{CC} @ 5.5 V		25	ns/V	

GUARANTEED OPERATING CONDITIONS (continued)

Symbol	Parameter	Min	Typ	Max	Unit
t_r, t_f	Input Rise and Fall Time (Note 2) ACT Devices	$V_{CC} @ 4.5 V$		10	ns/V
		$V_{CC} @ 5.5 V$		8.0	ns/V
T_A	Operating Ambient Temperature Range	-40	25	85	°C
C_{IN}	Input Capacitance $V_{CC} = 5.0 V$	$V_{CC} = 5.0 V$	4.5		pF
C_{PD}	Power Dissipation Capacitance	$V_{CC} = 5.0 V$	30		pF

 1. V_{IN} from 30% to 70% V_{CC}

 2. V_{IN} from 0.8 to 2.0 V

AC — 00
DC ELECTRICAL CHARACTERISTICS

Symbol	Parameter	Conditions	V_{CC} (V)	AC00			Unit		
				$T_A = +25^\circ C$		$T_A = -40$ to $+85^\circ C$			
				Typ	Guaranteed Limits				
V_{IH}	Minimum High Level Input Voltage	$V_{OUT} = 0.1V$ or $V_{CC} - 0.1 V$	3.0	1.5	2.1	2.1	V		
			4.5	2.25	3.15	3.15			
			5.5	2.75	3.85	3.85			
V_{IL}	Maximum Low Level Input Voltage	$V_{OUT} = 0.1V$ or $V_{CC} - 0.1 V$	3.0	1.5	0.9	0.9	V		
			4.5	2.25	1.35	1.35			
			5.5	2.75	1.65	1.65			
V_{OH}	Minimum High Level Output Voltage	$I_{OUT} = -50 \mu A$	3.0	2.99	2.9	2.9	V		
			4.5	4.49	4.4	4.4			
			5.5	5.49	5.4	5.4			
		$V_{IN} = V_{IL}$ or V_{IH}	I_{OH}	-12mA	3.0		2.56	2.46	V
				-24mA	4.5		3.86	3.76	
				-24mA	5.5		4.86	4.76	
V_{OL}	Maximum Low Level Output Voltage	$I_{OUT} = 50 \mu A$	3.0	0.002	0.1	0.1	V		
			4.5	0.001	0.1	0.1			
			5.5	0.001	0.1	0.1			
		$V_{IN} = V_{IL}$ or V_{IH}	I_{OL}	12mA	3.0		0.36	0.44	V
				24mA	4.5		0.36	0.44	
				24mA	5.5		0.36	0.44	
I_{IN}	Maximum Input Leakage Current	$V_{IN} = V_{CC}$ or GND	5.5		± 0.1	± 1.0	μA		
I_{CC}	Maximum Quiescent Supply Current	$V_{IN} = V_{CC}$ or GND	5.5		4.0	40	μA		

AC CHARACTERISTICS over full operating conditions

Symbol	Parameter	V_{CC} $\pm 10\%$ (V)	AC00				Unit
			$T_A = +25^\circ C$ $C_L = 50 pF$		$T_A = -40^\circ C$ to $+85^\circ C$ $C_L = 50 pF$		
			Min	Max	Min	Max	
t_{PLH}	Propagation Delay	3.3	2.0	9.5	2.0	10.0	ns
		5.0	1.5	8.0	1.5	8.5	
t_{PHL}	Propagation Delay	3.3	1.5	8.0	1.0	8.5	ns
		5.0	1.5	6.5	1.0	7.0	

DC ELECTRICAL CHARACTERISTICS

Symbol	Parameter	Conditions	V _{CC} (V)	ACT00			Unit
				T _A = +25°C		T _A = -40 to +85°C	
				Typ	Guaranteed Limits		
V _{IH}	Minimum High Level Input Voltage	V _{OUT} = 0.1V or V _{CC} - 0.1 V	4.5 5.5	1.5 1.5	2.0 2.0	2.0 2.0	V
V _{IL}	Maximum Low Level Input Voltage	V _{OUT} = 0.1V or V _{CC} - 0.1 V	4.5 5.5	1.5 1.5	0.8 0.8	0.8 0.8	V
V _{OH}	Minimum High Level Output Voltage	I _{OUT} = -50 μA	4.5 5.5	4.49 5.49	4.4 5.4	4.4 5.4	V
		V _{IN} = V _{IL} or V _{IH} I _{OH} = -24mA -24 mA	4.5 5.5		3.86 4.86	3.76 4.76	V
V _{OL}	Maximum Low Level Output Voltage	I _{OUT} = 50 μA	4.5 5.5	0.001 0.001	0.1 0.1	0.1 0.1	V
		V _{IN} = V _{IL} or V _{IH} I _{OL} = 24mA 24 mA	4.5 5.5		0.36 0.36	0.44 0.44	V
I _{IN}	Maximum Input Leakage Current	V _{IN} = V _{CC} or GND	5.5		±0.1	±1.0	μA
ΔI _{CC} T	Additional Max I _{CC} /Input	V _{IN} = V _{CC} - 2.1 V	5.5	0.6		1.5	mA
I _{CC}	Maximum Quiescent Supply Current	V _{IN} = V _{CC} or GND	5.5		4.0	40	μA

AC CHARACTERISTICS over full operating conditions

Symbol	Parameter	V _{CC} ±10% (V)	ACT00				Unit
			T _A = +25°C C _L = 50 pF		T _A = -40°C to +85°C C _L = 50 pF		
			Min	Max	Min	Max	
t _{PLH}	Propagation Delay	5.0	1.5	9.0	1.0	9.5	ns
t _{PHL}	Propagation Delay	5.0	1.5	7.0	1.0	8.0	ns

SWITCHING WAVEFORMS

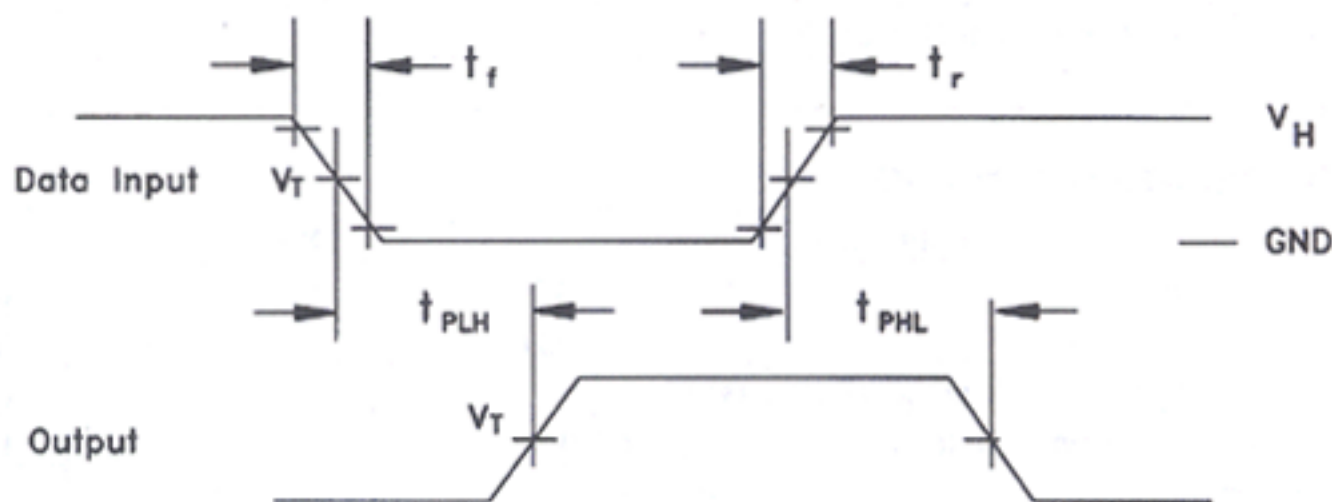

Input and output threshold voltage:
 V_T = 50% V_{CC} for AC; 1.5V for ACT
 V_H = V_{CC} for AC, 3V for ACT