

24V DRIVE INTERFACE BOARD (PARALLEL)

FTP-622DCL001/011/ FTP-622DSL001/011/012

FOR FTP-622/632/642MCL001/002/301/302/303/304

■ INTERFACE

1. Centronics

(1) Connector (CN1)

Connector part number : FCN-605Q030-G/S (Fujitsu Components)

Mating connector part number : FCN-607B030-G/D (Fujitsu Components) or equivalent

(2) Connector pin assignment

No.	Signal	I/O	Contents	No.	Signal	I/O	Contents
1	PRSTB	I	Data strobe	2	$\overline{\text{PRSTB}}\text{-RET}$	—	Connected to logic GND
3	PRDT0	I	Data 0	4	PRDT0-RET	—	Connected to logic GND
5	PRDT1	I	Data 1	6	PRDT1-RET	—	Connected to logic GND
7	PRDT2	I	Data 2	8	PRDT2-RET	—	Connected to logic GND
9	PRDT3	I	Data 3	10	PRDT3-RET	—	Connected to logic GND
11	PRDT4	I	Data 4	12	PRDT4-RET	—	Connected to logic GND
13	PRDT5	I	Data 5	14	PRDT5-RET	—	Connected to logic GND
15	PRDT6	I	Data 6	16	PRDT6-RET	—	Connected to logic GND
17	PRDT7	I	Data 7	18	PRDT7-RET	—	Connected to logic GND
19	$\overline{\text{ACKNLG}}$	O	Data input acknowledge	20	$\overline{\text{ACKNLG}}\text{-RET}$	—	Connected to logic GND
21	BUSY	O	Busy	22	BUSY-RET	—	Connected to logic GND
23	RINF2	O	Printer status	24	$\overline{\text{INPRM}}\text{-RET}$	—	Connected to logic GND
25	$\overline{\text{SLCTIN}}$	I	Printer select	26	$\overline{\text{INPRM}}$	I	Reset
27	RINF1	O	Printer status	28	RINF3	O	Printer status
29	$\overline{\text{ATF}}$	I	Paper feed request	30	GND	—	Logic GND

Notes:

- Symbol “—” means a negative logic signal.
- “-RET” signal is a return signal of the twisted pair cable.
- “I” or “O” means a signal direction from the interface board side.

(3) Connector pin number

FCN-605Q030-G/S (Fujitsu Components) or equivalent

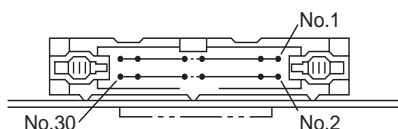

(4) Data input signal timing

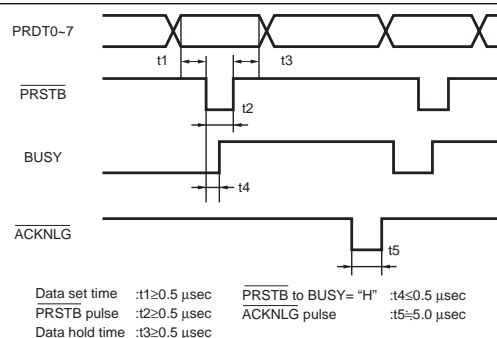

Product	Part Number	Function
Parallel Interface Board	FTP-622DCL001	Standard (without cutter)
	FTP-622DCL011	With cutter control
Serial Interface Board	FTP-622DSL001	Standard (without cutter)
	FTP-622DSL011	With cutter controller
	FTP-622DSL012	With cutter controller + FLASH ROM
	FTP-622DSL112	With Cutter + KANJI+FLASH ROM

■ SPECIFICATION

Item	Specification
Data receive speed	19200, 9600, 4800, 1200 bps (set by dip switch)
Synchronous method	Asynchronous, full duplex
Hand shake	DTR/DSR signal or XON/XOFF
Input output level	RS232C
Signal level	Space (logic = 0) +3 V ~ +12 V Mark (logic = 0) -3 V ~ -12 V

2. SERIAL INTERFACE (RS232C)

(1) Connector (CN2)

Part number : B6B-XH-A (J.S.T)

Mating connector part number : XHP-6 (J.S.T) or equivalent

(2) Pin assignment

No.	Signal	I/O	Contents	No.	Signal	I/O	Contents
1	FG	—	Frame GND	2	RD	I	Receive data
3	TD	O	Transmission Data	4	DTR	O	Data terminal ready
5	GND	—	Signal GND	6	DSR	I	Data set ready

Notes: "I" or "O" means a signal direction from the interface board side.

(3) Pin number

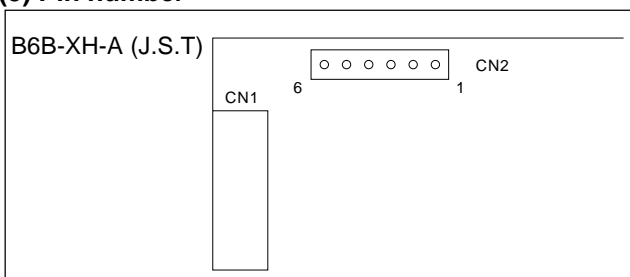

■ CONNECTOR PIN ASSIGNMENT

1. Connector for power supply (CN10)

Part number : B6P-VH (J.S.T)

Mating connector part number : VHR-6N (J.S.T) or equivalent

No.	Signal	I/O	Contents	No.	Signal	I/O	Contents
1	V _{CC}	—	Power supply for logic (+5 V)	2	GND	—	GND (5 V, 24 V common)
3	GND	—	GND (5 V, 24 V common)	4	GND	—	GND (5 V, 24 V common)
5	V _{DD}	—	Power for head/motor (+24 V)	6	V _{DD}	—	Power for head/motor (+24 V)

2. Connector for thermal head drive (CN8)

Part number : B16B-PH-K-S (J.S.T)

Mating connector part number : PHR-16 (J.S.T) or equivalent

No.	Signal	I/O	Contents	No.	Signal	I/O	Contents
1	VDH	O	Power for head (+24 V)	2	VDH	O	Power for head (+24 V)
3	GND (VDH)	—	Head GND	4	GND (VDH)	—	Head GND
5	$\overline{\text{STB1}}$	O	Print enable signal 1	6	$\overline{\text{STB2}}$	O	Print enable signal 2
7	$\overline{\text{STB3}}$	O	Print enable signal 3	8	TMP	I	Temperature detection signal
9	$\overline{\text{STB4}}$	O	Print enable signal 4	10	$\overline{\text{LAT}}$	O	Print data latch signal
11	$\overline{\text{STB5}}$	O	Print enable signal 5	12	5 VH	O	Power for logic (+5 V)
13	HCLK	O	Data transmission clock	14	HD	O	Print data output signal
15	GND (VDH)	—	Head GND	16	VDH	O	Power for head (+24 V)

Notes:

- Symbol “—” means a negative logic signal.
- “I” or “O” means a signal direction from the interface board side.

3. Connector for Sensor (CN3)

Part number : B5B-PH-K-S (J.S.T)

No.	Signal	I/O	Contents	No.	Signal	I/O	Contents
1	+5 V	—	Power for logic (+5 V)	2	$\overline{\text{PES}}$	I	Paper end detect signal
3	GND (5 V)	—	Logic GND	4	+5 V	—	Power for logic (+5 V)
5	HUP	I	Head-up detect signal				

7. Connector for control signal input/ output (CN1)

Part number : FCN-605Q030-G/S (Fujitsu Components)

Mating connector : FCN-607B030-G/D (Fujitsu Components) or equivalent

No.	Signal	I/O	Contents	No.	Signal	I/O	Contents
1	NC	—	No connection	2	NC	—	No connection
3	NC	—	No connection	4	NC	—	No connection
5	NC	—	No connection	6	NC	—	No connection
7	NC	—	No connection	8	NC	—	No connection
9	NC	—	No connection	10	NC	—	No connection
11	NC	—	No connection	12	NC	—	No connection
13	NC	—	No connection	14	NC	—	No connection
15	NC	—	No connection	16	NC	—	No connection
17	NC	—	No connection	18	NC	—	No connection
19	NC	—	No connection	20	NC	—	No connection
21	NC	—	No connection	22	NC	—	No connection
23	NC	—	No connection	24	NC	—	No connection
25	$\overline{\text{SLCTIN}}$	I	Select signal	26	$\overline{\text{INPRM}}$	I	Reset signal
27	NC	—	No connection	28	NC	—	No connection
29	$\overline{\text{ATF}}$	I	Paper feed request	30	GND	—	GND

*Do not connect outside signal to NC.

4. Connector for paper near end detection (CN5)

Part number : B2B-PH-K-S (J.S.T)

Mating connector part number : PHR-2 (J.S.T) or equivalent

No.	Signal	I/O	Contents	No.	Signal	I/O	Contents
1	+5 V	—	Power for logic (+5 V)	2	$\overline{\text{NES}}$	I	Paper near end detect signal

5. Connector for stepping motor drive (CN13)

Part number : B4B-PH-K-S (J.S.T)

No.	Signal	I/O	Contents	No.	Signal	I/O	Contents
1	$\text{MT}/\overline{\text{B}}$	O	Stepping motor coil excitation	2	MT/B	O	Stepping motor coil excitation
3	$\text{MT}/\overline{\text{A}}$	O	Stepping motor coil excitation	4	MT/A	O	Stepping motor coil excitation

6. Connector for cutter drive (CN11) *1

Part number : B4B-EH (J.S.T)

No.	Signal	I/O	Contents	No.	Signal	I/O	Contents
1	SW1	I	Cutter position detect signal	2	GND	—	Logic ground
3	M+	O	Motor control signal (+)	4	M-	O	Motor control signal (-)

*1: Only for FTP-622DCL011/111.

■ PRINTING COMMANDS (CENTRONICS INTERFACE)

Command	Contents
HT	Moves the print position to the next tab.
LF	Line feed.
FF	Feeds forms (new page).
ESC RS	Sets reverse printing.
ESC US	Resets reverse printing.
ESC ! +n	Sets print mode.
ESC* +m+n ₁ +n ₂ +d ₁ ~d _N	Sets the bit image mode "m" for n ₁ , n ₂ dot numbers.
ESC 2	Sets 1/6 inch line feed length.
ESC 3 + n	Sets the line feed length.
ESC @	Printer initialization.
ESC A+n	Sets the space between lines.
ESC C+n	Sets the page length by character line.
ESC D+d ₁ ~d _N +NUL	Sets the tab position.
ESC J+n	Feeds paper in forward direction.
ESC K+n	Feeds paper in reverse direction.
ESC c+1+n	Sets the internal processing.
ESC R+n	Selects the international character.
ESC s+n	Sets the printing speed.
ESC d+n	Printing and n-line feeding.
ESC e+n	Reverse line feed in "n" lines after printing.
ESC t+n	Character code table selection.
ESC {+n	Sets/resets the upside down printing.
ECS EM+n	Automatic paper feed distance setting.
ESC X+n+m	Setting turning time of the motor excitation.
ESC V+n	Right Rotation 90° specification / cancellation.
ESC %+n	Selects the font to download* ³ .
ESC &+y+c ₁ +c ₂ +x+d ₁ ~d _n	Registers the download front* ³ .
ESC ?+n	External character registration deletion* ³ .
FS E+n	Correction of impressed energy.
FS ! +n	Sets the Kanji print mode* ¹ .
FS &	Sets Kanji mode* ¹ .

(Continued)

(Continued)

Command	Contents
FS .	Resets Kanji mode* ¹ .
FS C+n	Selects Kanji code type* ¹ .
FS 9+n	Sets the detection functions.
FS*+m+n1+n2+d1~dn	Prints image data on SRAM* ³ .
FS r+n	Notifies of printing finish* ⁴ .
FS W+n	Sets/resets 4 times enlarged character.
GS <	Line feeds to the next mark.
GS A+m+n	Sets the line feed length after mark detection.
GS E+n	Sets print quality.
GS V+n+m	Executes paper cutting* ² .
GS e+n+m	Sets the bar width.
GS h+n	Sets the barcode height.
GS k+m+n+d1~dn	Selects the barcode type and prints.
GS w+n	Sets the barcode length.
GS &+m+x+y1+y2+[d]k	Registration of image data* ³ .
GS '+m+n	Prints registered image data * ³ .
GS a+n	Sets and cancels status transmission (valid only for DSL)* ³ .

*1: Only for FTP-622DSL112.

*2: Only for FTP-622DCL011 or FTP-622DSL011/012.

*3: Only for FTP-622DSL012.

*4: Only for FTP-622DSL011/012.

■ OPTIONS

1. Cable (With FTP-622MCL, FTP-632MCL, FTP-642MCL)

Name	Part Number	Cable Length
Thermal head connection cable (CN8)*	FTP-622Y001	270 mm (10.6 inches)
Interface cable	Centronics (CN1)	FTP-622Y201
	Serial (CN2)	FTP-622Y301
Power cable for head, motor, and logic (CN10)	FTP-622Y401	300 mm (11.8 inches)
* short cable option	FTP-624Y001	150 mm (5.9 inches)

2. Paper holder

Name	Part number
Flange	FTP-040HF
Stand	FTP-040HS

Fujitsu Components International Headquarter Offices

Japan

Fujitsu Component Limited
Gotanda-Chuo Building
3-5, Higashigotanda 2-chome, Shinagawa-ku
Tokyo 141, Japan
Tel: (81-3) 5449-7010
Fax: (81-3) 5449-2626
Email: promothq@ft.ed.fujitsu.com
Web: www.fcl.fujitsu.com

North and South America

Fujitsu Components America, Inc.
250 E. Caribbean Drive
Sunnyvale, CA 94089 U.S.A.
Tel: (1-408) 745-4900
Fax: (1-408) 745-4970
Email: marcom@fcai.fujitsu.com
Web: www.fcai.fujitsu.com

Europe

Fujitsu Components Europe B.V.
Diamantlaan 25
2132 WV Hoofddorp
Netherlands
Tel: (31-23) 5560910
Fax: (31-23) 5560950
Email: info@fceu.fujitsu.com
Web: www.fceu.fujitsu.com

Asia Pacific

Fujitsu Components Asia Ltd.
102E Pasir Panjang Road
#04-01 Citilink Warehouse Complex
Singapore 118529
Tel: (65) 6375-8560
Fax: (65) 6273-3021
Email: fcal@fcal.fujitsu.com
www.fcal.fujitsu.com

© 2004 Fujitsu Components America, Inc. All company and product names are trademarks or registered trademarks of their respective owners. Rev. 11/15/2004.