



TAI-SAW TECHNOLOGY CO., LTD.

No. 3, Industrial 2nd Rd., Ping-Chen Industrial District,
Taoyuan, 324, Taiwan, R.O.C.

TEL: 886-3-4690038 FAX: 886-3-4697532

E-mail: tstsales@mail.taisaw.com Web: www.taisaw.com

Approval Sheet For Product Specification

Issued Date:

Product Name: SAW Filter 86.6 MHz SMD 19x6.5 mm

TST Parts No.:TB0497A

Customer Parts No.:_____

Company: _____
Division: _____
Approved by : _____
Date: _____

Checked by: _____ Andy Lee

Approval by: _____ Francis Chen

Date: _____ 9, 12, 2007

www.DataSheet4U.com



TAI-SAW TECHNOLOGY CO., LTD.

No. 3, Industrial 2nd Rd., Ping-Chen Industrial District,
Taoyuan, 324, Taiwan, R.O.C.

TEL: 886-3-4690038 FAX: 886-3-4697532

E-mail: tstsales@mail.taisaw.com Web: www.taisaw.com

SAW Filter 86.6 MHz

MODEL NO.: TB0497A

REV. No.1

A. MAXIMUM RATING:

1. Input Power Level : 20 dBm
2. Operating Temperature: -40°C to 85°C
3. Storage Temperature: -40°C to 85°C

RoHS Compliant
Lead free
Lead-free soldering

B. ELECTRICAL CHARACTERISTICS:

Item	Unit	Min.	Type.	Max.	Note
Center frequency, F_c	MHz	-	86.6	-	-
Minimum Insertion Loss, IL	dB	-	5.5	6.5	-
Lower 3.5 dB point	MHz	86.40	86.41		-
Upper 3.5 dB point	MHz		86.75	86.80	-
Lower 28 dB point	MHz	85.80	86.18		-
Upper 28 dB point	MHz		86.98	87.40	-
Amplitude Ripple	MHz	-	0.7	1.0	-
Group delay ripple	ns	-	70	200	-
Ultimate Rejection	dB	33	40	-	-
VSWR	-	-	1.6:1	2.0:1	-
Substrate Material	-	-	Quartz	-	-

C. MEASUREMENT CIRCUIT:

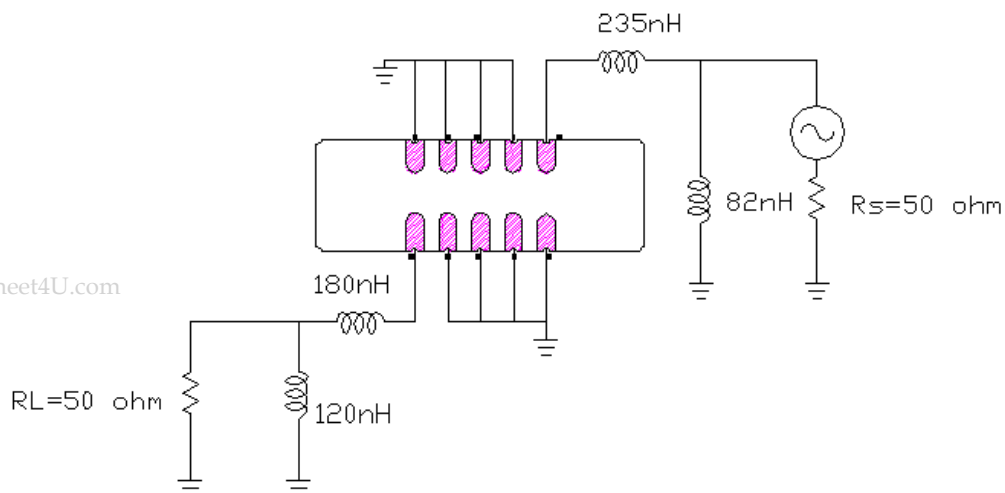

www.DataSheet4U.com

D. FREQUENCY CHARACTERISTICS :

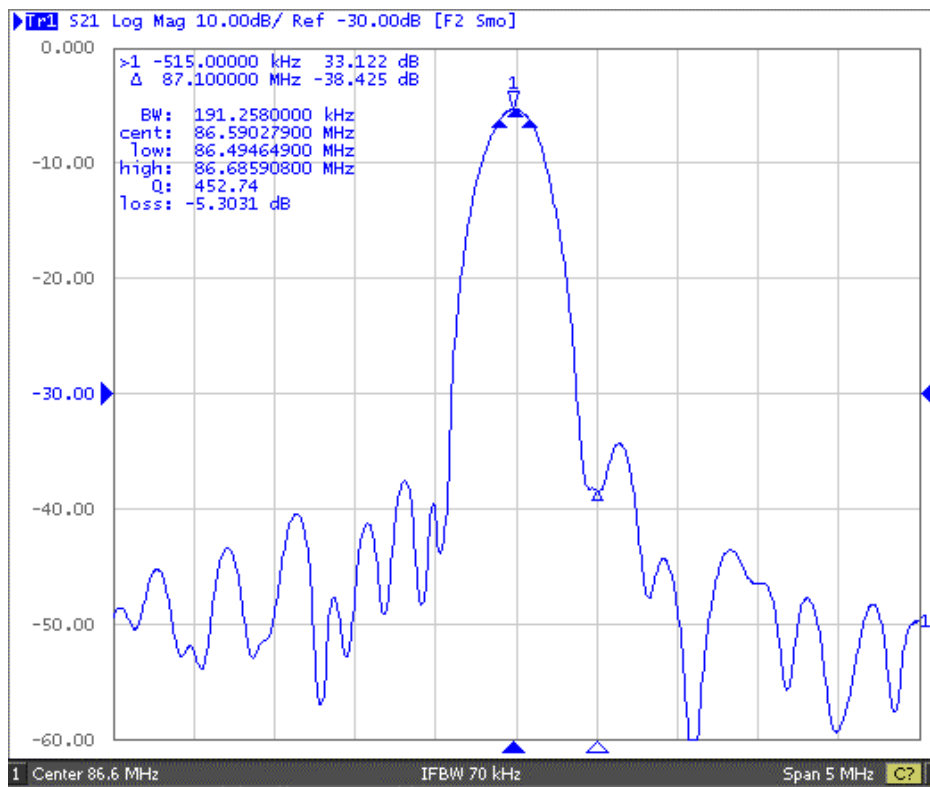

Fig-1 S21 Response Horizontal: 0.5MHz/Div Vertical: 10dB/Div

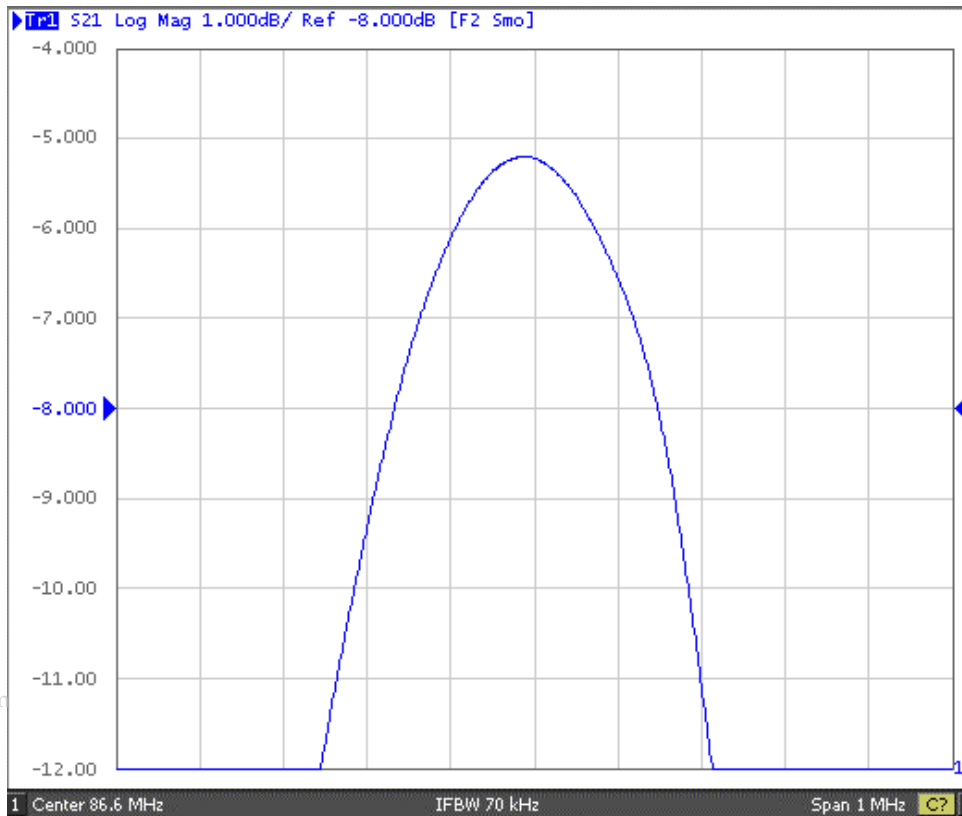

Fig-2 Amplitude Ripple Horizontal: 0.1MHz/Div Vertical: 1dB/Div

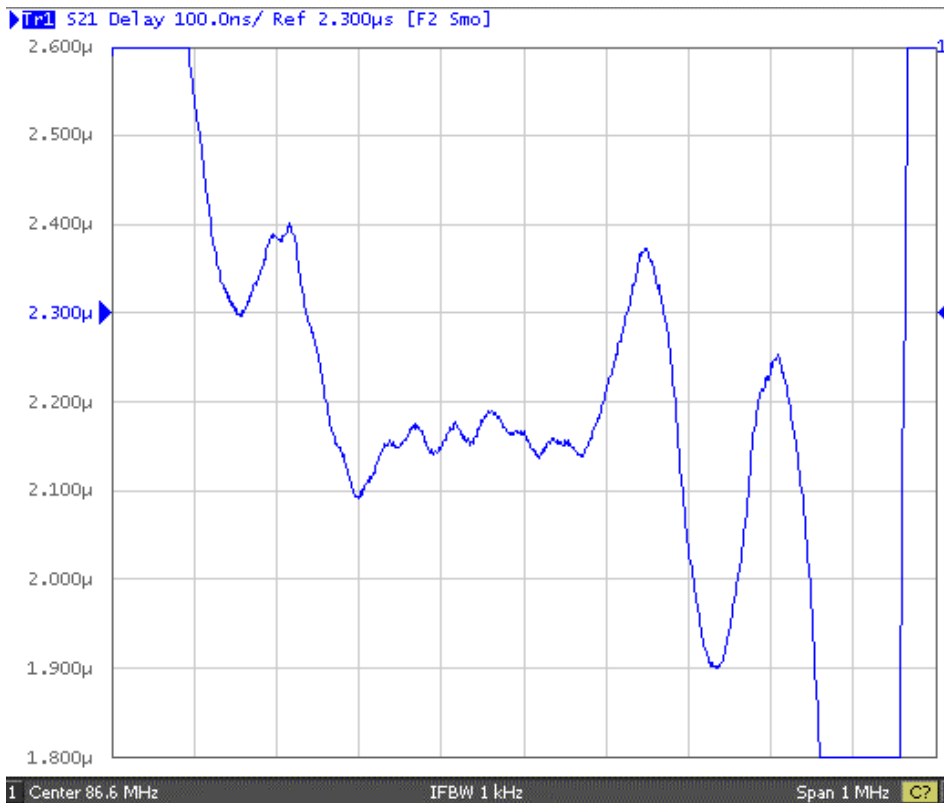
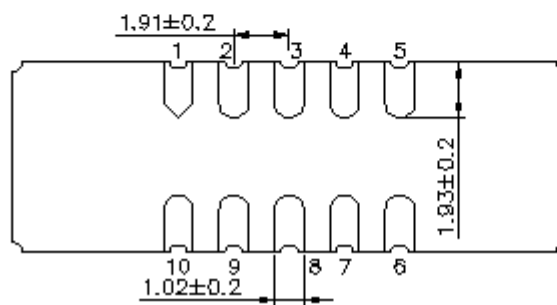
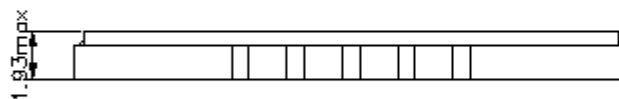
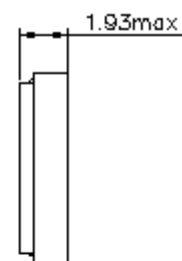
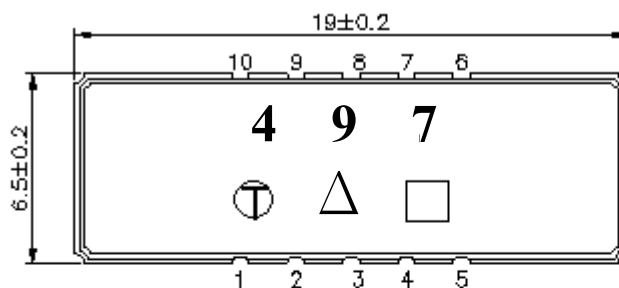

Fig-3 Group Delay Ripple: Horizontal: 0.1MHz/Div Vertical:100nS/Div

E. OUTLINE DRAWING :



Pin configuration

- #10 RF Input
- #1 RF Input ground
- #5 RF Output
- #6 RF Output ground
- #2,3,4,7,8,9 To be ground

□ : Week Code (Follow the table from planner each year)

△ : Product / Year Code

Year	2005 2009	2006 2010	2007 2011	2008 2012
Product Code	B	b	<u>B</u>	<u>b</u>

F. PCB FOOTPRINT:

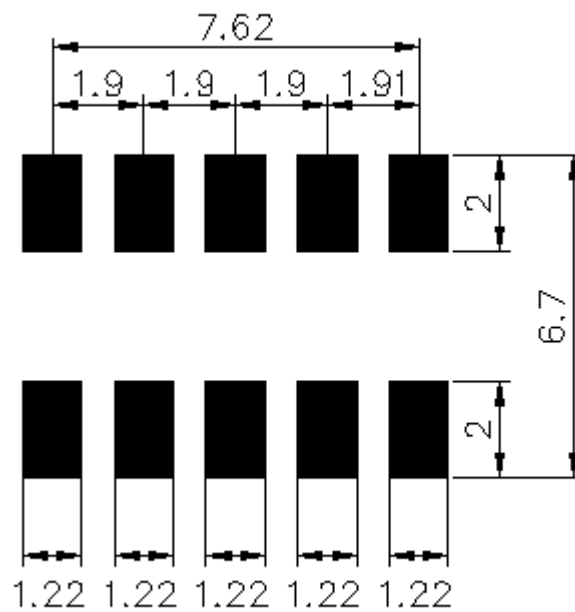

G. PACKAGE:

1. REEL DIMENSION

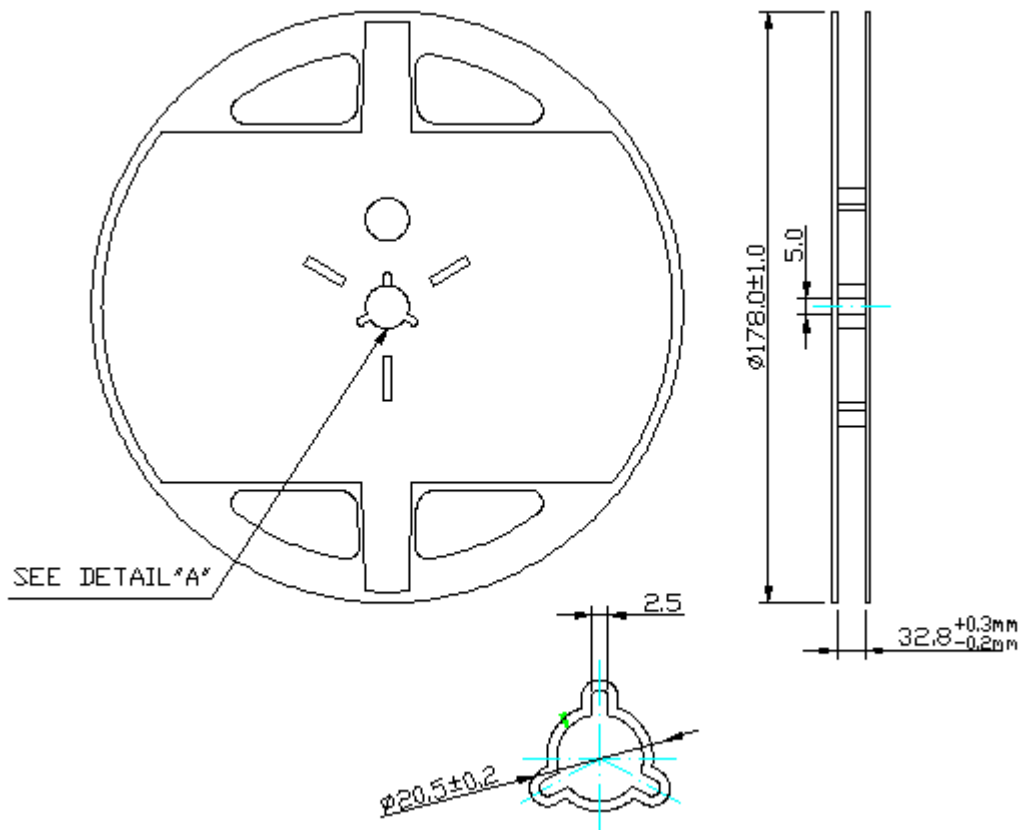

2. TAPE DIMENSION

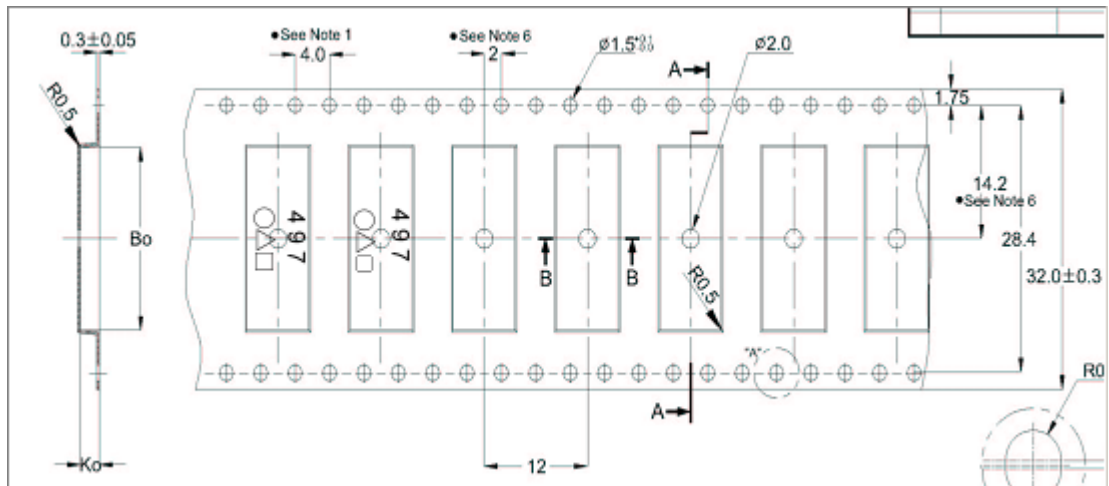

www.DataSheet4U.com

Direction of feed

