

TOSHIBA Bi-CMOS Integrated Circuit Silicon Monolithic

TB62777FNG

8-Channel Constant-Current LED Driver of the 3.3-V and 5-V Power Supply Voltage Operation

The TB62777FNG is comprised of constant-current drivers designed for LEDs and LED panel displays.

The regulated current sources are designed to provide a constant current, which is adjustable through one external resistor.

The TB62777FNG incorporates eight channels of shift registers, latches, AND gates and constant-current outputs.

Fabricated using the Bi-CMOS process, the TB62777FNG satisfies the system requirement of high-speed data transmission.

The TB62777FNG is RoHS.

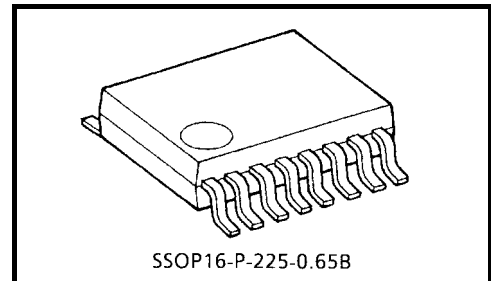

Weight: 0.07 g (typ.)

Features

- Power supply voltages: $V_{DD} = 3.3\text{ V}/5\text{ V}$
- Output drive capability and output count: $50\text{ mA} \times 8\text{ channels}$
- Constant-current output range: 5 to 40 mA
- Voltage applied to constant-current output terminals: 0.4 V ($I_{OUT} = 5\text{ to }40\text{ mA}$)
- Designed for common-anode LEDs
- Thermal shutdown (TSD) (MIN:150)
- Power on reset (POR)
- Input signal voltage level: 3.3-V and 5-V CMOS interfaces (Schmitt trigger input)
- Maximum output voltage: 25V
- Serial data transfer rate: 25 MHz (max) @cascade connection
- Operating temperature range: $T_{opr} = -40\text{ to }85^\circ\text{C}$
- Package: SSOP-P-225-0.65B
- Constant-current accuracy

| Output Voltage | Current accuracy Between Channels | Current Accuracy Between ICs | Output Current |
|----------------|-----------------------------------|------------------------------|----------------|
| 0.4 V to 4 V | $\pm 3\%$ | $\pm 6\%$ | 15 mA |



Web: www.marktechopto.com | Email: info@marktechopto.com

Pin Assignment (top view)

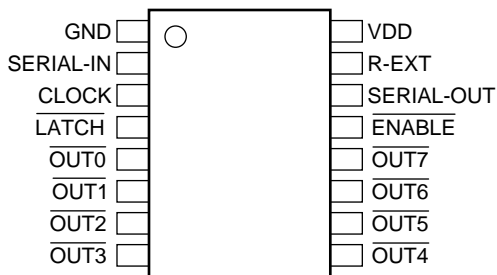

Block Diagram

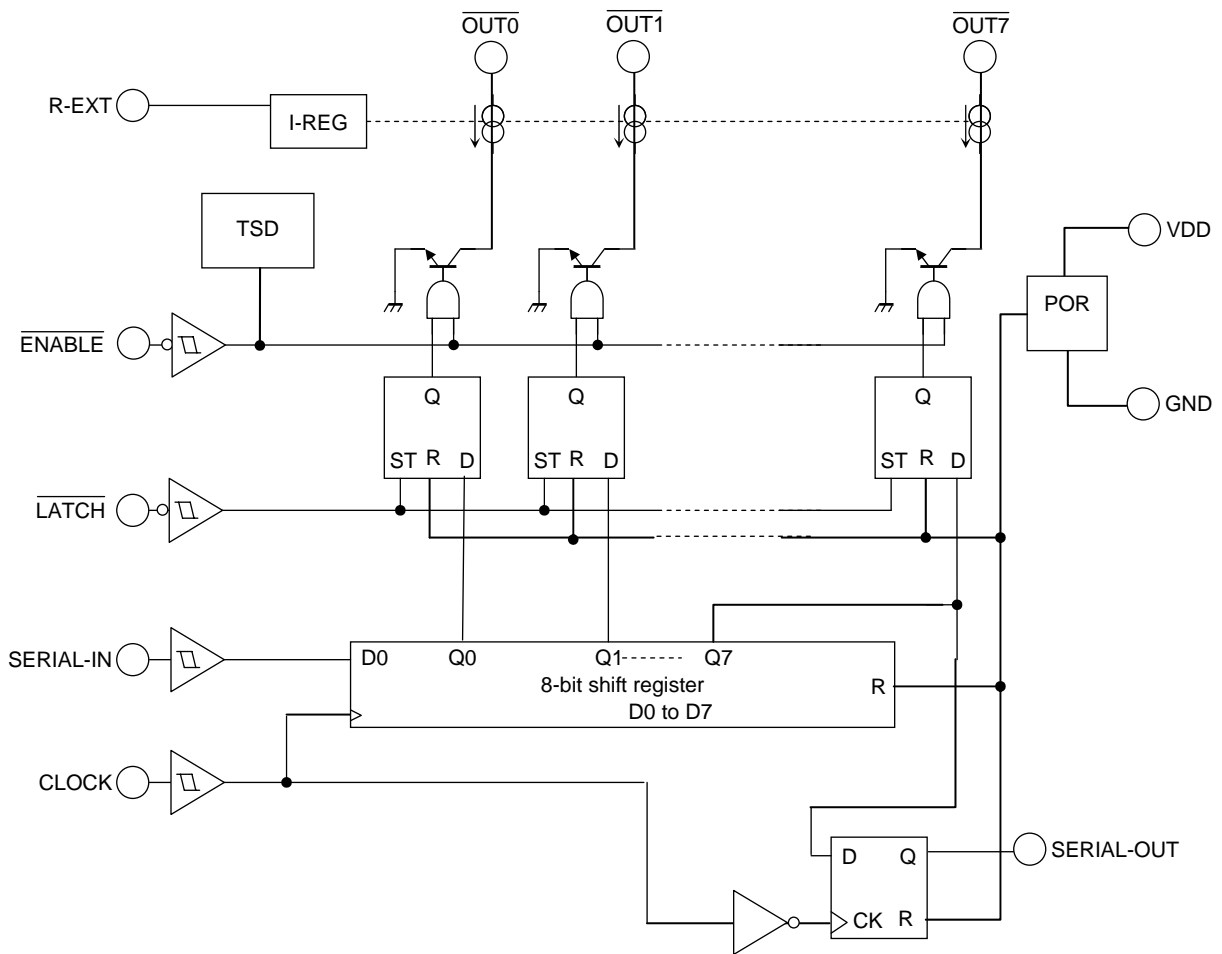

Truth Table

| CLOCK | LATCH | ENABLE | SERIAL-IN | OUT0 ... OUT5 ... OUT7 | SERIAL-OUT |
|-------|-------|--------|-----------|------------------------------|------------|
| ↑ | H | L | Dn | Dn ... Dn - 5 ... Dn - 7 | No change |
| ↑ | L | L | Dn + 1 | No Change | No change |
| ↑ | H | L | Dn + 2 | Dn + 2 ... Dn - 3 ... Dn - 5 | No change |
| ↑ | X | H | Dn + 3 | OFF | No change |
| ↓ | X | H | Dn + 3 | OFF | Dn - 4 |

Note 1: $\overline{\text{OUT0}}$ to $\overline{\text{OUT7}}$ = On when Dn = H; $\overline{\text{OUT0}}$ to $\overline{\text{OUT7}}$ = Off when Dn = L.

Timing Diagram

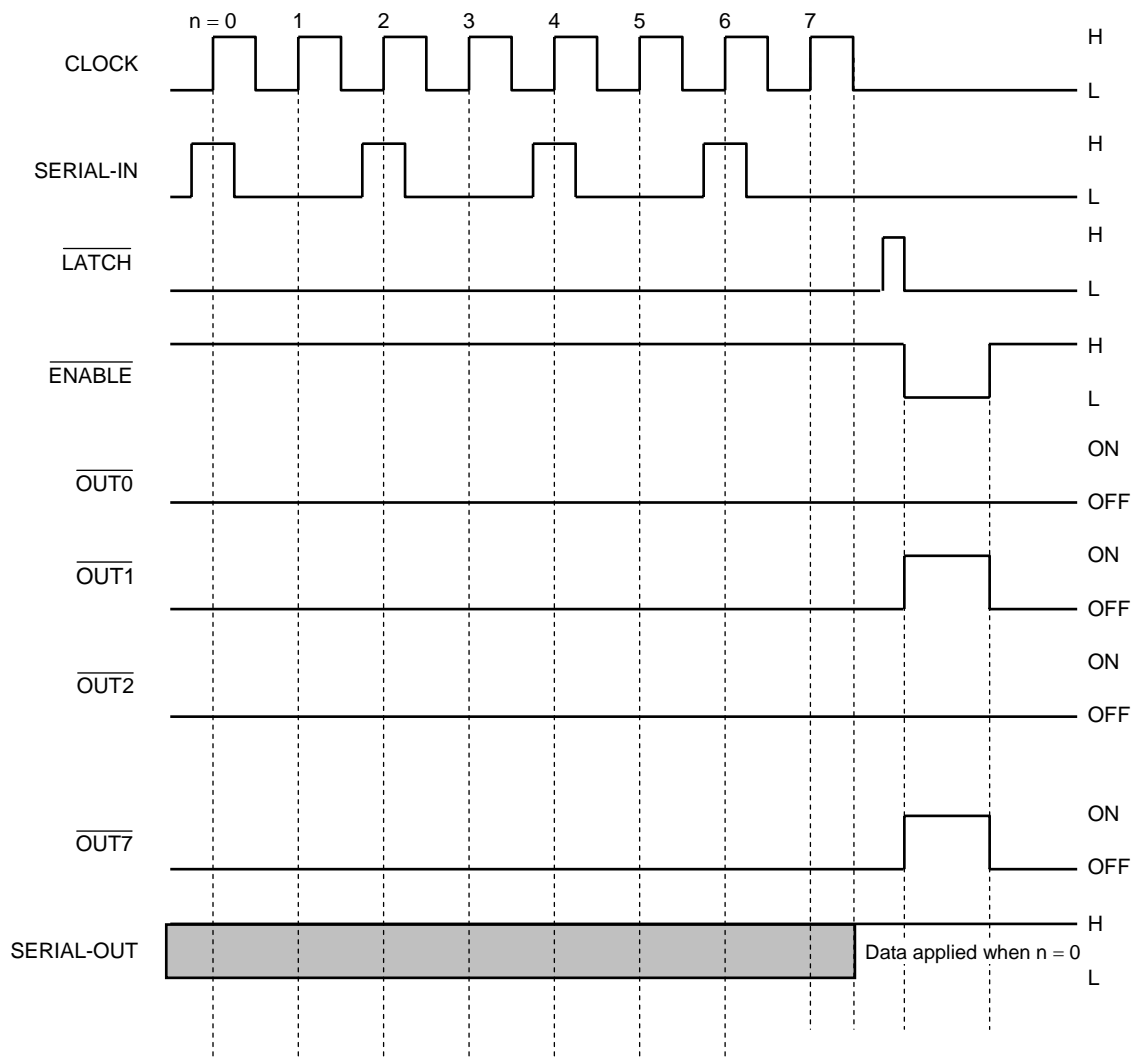

Note 1: Latches are level-sensitive, not edge-triggered.

Note 2: The TB62777FNG can be used at 3.3 V or 5.0 V. However, the V_{DD} supply voltage must be equal to the input voltage.

Note 3: Serial data is shifted out of SERIAL-OUT on the falling edge of CLOCK.

Note 4: The latches hold data while the $\overline{\text{LATCH}}$ terminal is held Low. When the $\overline{\text{LATCH}}$ terminal is High, the latches do not hold data and pass it transparently. When the $\overline{\text{ENABLE}}$ terminal is Low, $\overline{\text{OUT0}}$ to $\overline{\text{OUT7}}$ toggle between ON and OFF according to the data. When the $\overline{\text{ENABLE}}$ terminal is High, $\overline{\text{OUT0}}$ to $\overline{\text{OUT7}}$ are forced OFF.

Terminal Description

| Pin No. | Pin Name | Function |
|---------|----------------------------|---|
| 1 | GND | GND terminal |
| 2 | SERIAL-IN | Serial data input terminal |
| 3 | CLOCK | Serial clock input terminal |
| 4 | $\overline{\text{LATCH}}$ | Latch input terminal |
| 5 | $\overline{\text{OUT0}}$ | Constant-current output terminal |
| 6 | $\overline{\text{OUT1}}$ | Constant-current output terminal |
| 7 | $\overline{\text{OUT2}}$ | Constant-current output terminal |
| 8 | $\overline{\text{OUT3}}$ | Constant-current output terminal |
| 9 | $\overline{\text{OUT4}}$ | Constant-current output terminal |
| 10 | $\overline{\text{OUT5}}$ | Constant-current output terminal |
| 11 | $\overline{\text{OUT6}}$ | Constant-current output terminal |
| 12 | $\overline{\text{OUT7}}$ | Constant-current output terminal |
| 13 | $\overline{\text{ENABLE}}$ | Output enable input terminal All outputs ($\overline{\text{OUT0}}$ to $\overline{\text{OUT7}}$) are disabled when the $\overline{\text{ENABLE}}$ terminal is driven High, and enabled when it is driven Low. |
| 14 | SERIAL-OUT | Serial data output terminal. Serial data is clocked out on the falling edge of CLOCK. |
| 15 | R-EXT | An external resistor is connected between this terminal and ground. $\overline{\text{OUT0}}$ to $\overline{\text{OUT7}}$ are adjusted to the same current value. |
| 16 | V _{DD} | Power supply terminal |

Equivalent Circuits for Inputs and Outputs

CLOCK, SERIAL-IN, $\overline{\text{ENABLE}}$, $\overline{\text{LATCH}}$ 端子

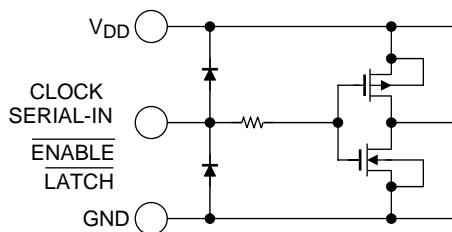

SERIAL-OUT 端子

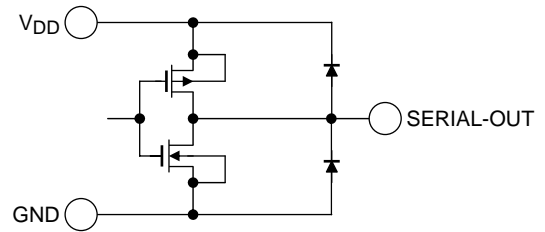

$\overline{\text{OUT0}}$ ~ $\overline{\text{OUT7}}$ 定電流出力端子

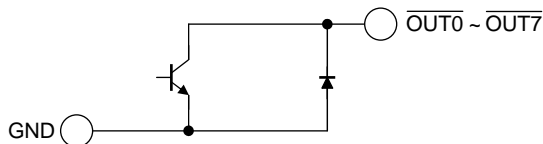

Absolute Maximum Ratings (Ta = 25°C)

| Characteristics | Symbol | Rating | Unit |
|------------------------------|----------------------|--|-------|
| Supply voltage | V _{DD} | 6.0 | V |
| Input voltage | V _{IN} | -0.3 to V _{DD} + 0.3 (Note 1) | V |
| Output current | I _{OUT} | 55 | mA/ch |
| Output voltage | V _{OUT} | 0.3 to 25 | V |
| Power dissipation | P _d | 1.02 (Notes 2 and 3) | W |
| Thermal resistance | R _{th(j-a)} | 122 (Note 2) | °C/W |
| Operating temperature range | T _{opr} | -40 to 85 | °C |
| Storage temperature range | T _{stg} | -55 to 150 | °C |
| Maximum junction temperature | T _j | 150 | °C |

Note 1: However, do not exceed 6.0 V.

Note 2: When mounted on a PCB (76.2 × 114.3 × 1.6 mm; Cu = 30%; 35-μm-thick; SEMI-compliant)

Note 3: Power dissipation is reduced by 1/R_{th(j-a)} for each °C above 25°C ambient.

Operating Ranges (unless otherwise specified, Ta = -40°C to 85°C)

| Characteristics | Symbol | Test Condition | Min | Typ. | Max | Unit |
|--|---------------------|--|-----------------------|------|-----------------------|-------|
| Supply voltage | V _{DD} | — | 3 | — | 5.5 | V |
| Output voltage | V _{OUT} | $\overline{\text{OUT0}}$ to $\overline{\text{OUT7}}$ | 0.4 | — | 4 | V |
| Output current | I _{OUT} | $\overline{\text{OUT0}}$ to $\overline{\text{OUT7}}$ | 5 | — | 40 | mA/ch |
| | I _{OH} | SERIAL-OUT | — | — | -5 | mA |
| | I _{OL} | SERIAL-OUT | — | — | 5 | |
| Input voltage | V _{IH} | SERIAL-IN/CLOCK/ LATCH / ENABLE | 0.7 × V _{DD} | — | V _{DD} | V |
| | V _{IL} | | GND | — | 0.3 × V _{DD} | |
| Clock frequency | f _{CLK} | Cascade connection | — | — | 25 | MHz |
| $\overline{\text{LATCH}}$ pulse width | t _{wLAT} | (Note 2) | 20 | — | — | ns |
| CLOCK pulse width | t _{wCLK} | (Note 2) | 20 | — | — | |
| $\overline{\text{ENABLE}}$ pulse width | t _{wENA} | I _{OUT} ≥ 20 mA (Note 2) | 2 | — | — | μs |
| | | 5 mA ≤ I _{OUT} ≤ 20 mA (Note 2) | 3 | — | — | |
| Setup time | t _{SETUP1} | (Note 2) | 5 | — | — | ns |
| | t _{SETUP2} | | 5 | — | — | |
| Hold time | t _{HOLD1} | | 5 | — | — | |
| | t _{HOLD2} | | 5 | — | — | |
| Maximum clock rise time | t _r | Single operation (Notes 1 and 2) | — | — | 5 | μs |
| Maximum clock fall time | t _f | | — | — | 5 | |

Note 1: For cascade operation, the CLOCK waveform might become ambiguous, causing the t_r and t_f values to be large. Then it may not be possible to meet the timing requirement for data transfer. Please consider the timing carefully.

Note 2: Please see the timing waveform on page 10.

Electrical Characteristics (Unless otherwise specified, Ta = 25°C, VDD = 4.5 to 5.5 V)

| Characteristics | Symbol | Test Circuit | Test Condition | Min | Typ. | Max | Unit |
|---|-------------------------|--------------|--|-----------------------|------|-----------------------|------|
| Output current | I _{OUT1} | 5 | V _{OUT} = 0.4 V, R-EXT = 1.2 kΩ V _{DD} = 5 V, | | 15 | | mA |
| Output current error between ICs | ΔI _{OUT1} | 5 | V _{OUT} = 0.4 V, R-EXT = 1.2 kΩ All channels ON V _{DD} = 5 V, | | ±3 | ±6 | % |
| Output current error between channels | ΔI _{OUT2} | 5 | V _{OUT} = 0.4 V, R-EXT = 1.2 kΩ All channels ON V _{DD} = 5 V, | — | ±1 | ±3 | % |
| Output leakage current | I _{OZ} | 5 | V _{OUT} = 25 V | — | — | 1 | μA |
| Input voltage | V _{IH} | — | SERIAL-IN/CLOCK/LATCH / ENABLE | 0.7 × V _{DD} | — | V _{DD} | V |
| | V _{IL} | — | SERIAL-IN/CLOCK/LATCH / ENABLE | GND | — | 0.3 × V _{DD} | |
| Input current | I _{IH} | 2 | V _{IN} = V _{DD} CLOCK/SERIAL-IN /LATCH / ENABLE | | | 1 | μA |
| | I _{IL} | 3 | V _{IN} = GND CLOCK/SERIAL-IN/LATCH / ENABLE | | | -1 | |
| SERIAL-OUT output voltage | V _{OL} | 1 | I _{OL} = 5.0 mA, V _{DD} = 5 V | — | — | 0.3 | V |
| | V _{OH} | 1 | I _{OH} = -5.0 mA, V _{DD} = 5 V | 4.7 | — | — | |
| Changes in constant output current dependent on V _{DD} | %/V _{DD} | 5 | V _{DD} = 3 V to 5.5 V | — | 1 | 2 | % |
| Supply current | I _{DD} (OFF) 1 | 4 | R-EXT = OPEN, V _{OUT} = 25.0 V | — | — | 1 | mA |
| | I _{DD} (OFF) 2 | 4 | R-EXT = 1.2 kΩ, V _{OUT} = 25.0 V, All channels OFF | — | — | 5 | |
| | I _{DD} (ON) | 4 | R-EXT = 1.2 kΩ, V _{OUT} = 0.4 V, All channels ON | — | — | 9 | |

Switching Characteristics (Unless otherwise specified, Ta = 25°C, VDD = 4.5 to 5.5V)

| Characteristics | Symbol | Test Circuit | Test Condition (Note 1) | Min | Typ. | Max | Unit |
|------------------------|-------------------|--------------|--|-----|------|-----|------|
| Propagation delay time | t _{pLH1} | 6 | CLK-OUTn, LATCH = "H", ENABLE = "L" | — | 20 | 300 | ns |
| | t _{pLH2} | 6 | LATCH - OUTn, ENABLE = "L" | — | 20 | 300 | |
| | t _{pLH3} | 6 | ENABLE - OUTn, LATCH = "H" | — | 20 | 300 | |
| | t _{pLH} | 6 | CLK-SERIAL OUT | 2 | 10 | 14 | |
| | t _{pHL1} | 6 | CLK-OUTn, LATCH = "H", ENABLE = "L" | — | 30 | 340 | |
| | t _{pHL2} | 6 | LATCH - OUTn, ENABLE = "L" | — | 70 | 340 | |
| | t _{pHL3} | 6 | ENABLE - OUTn, LATCH = "H" | — | 70 | 340 | |
| | t _{pHL} | 6 | CLK-SERIAL OUT | 2 | 10 | 14 | |
| Output rise time | t _{or} | 6 | 10% to 90% points of OUT0 to OUT7 voltage waveforms | | 20 | 150 | |
| Output fall time | t _{of} | 6 | 90% to 10% points of OUT0 to OUT7 voltage waveforms | | 125. | 300 | |

Note 1: T_{opr} = 25°C, V_{DD} = V_{IH} = 5 V, V_{IL} = 0 V, R_{EXT} = 1.2 kΩ, I_{OUT} = 15mA, V_L = 5.0 V,
C_L = 10.5pF (see test circuit 6.)

Electrical Characteristics (Unless otherwise specified, Ta = 25°C, V_{DD} = 3 to 3.6 V)

| Characteristics | Symbol | Test Circuit | Test Condition | Min | Typ. | Max | Unit |
|---|-------------------------|--------------|--|-----------------------|------|-----------------------|------|
| Output current | I _{OUT1} | 5 | V _{OUT} = 0.4 V, R-EXT = 1.2 kΩ V _{DD} = 3.3 V, | | 15 | | mA |
| Output current error between ICs | ΔI _{OUT1} | 5 | V _{OUT} = 0.4 V, R-EXT = 1.2 kΩ All channels ON V _{DD} = 3.3 V, | | ±3 | ±6 | % |
| Output current error between channels | ΔI _{OUT2} | 5 | V _{OUT} = 0.4 V, R-EXT = 1.2 kΩ All channels ON V _{DD} = 3.3 V, | — | ±1 | ±3 | % |
| Output leakage current | I _{OZ} | 5 | V _{OUT} = 25 V | — | — | 1 | μA |
| Input voltage | V _{IH} | — | SERIAL-IN/CLOCK/LATCH / ENABLE | 0.7 × V _{DD} | — | V _{DD} | V |
| | V _{IL} | — | SERIAL-IN/CLOCK/LATCH / ENABLE | GND | — | 0.3 × V _{DD} | |
| Input current | I _{IH} | 2 | V _{IN} = V _{DD} CLOCK/SERIAL-IN/LATCH / ENABLE | | | 1 | μA |
| | I _{IL} | 3 | V _{IN} = GND CLOCK/SERIAL-IN/LATCH / ENABLE | | | -1 | |
| SERIAL-OUT output voltage | V _{OL} | 1 | I _{OL} = 5.0 mA, V _{DD} = 3.3 V | — | — | 0.3 | V |
| | V _{OH} | 1 | I _{OH} = -5.0 mA, V _{DD} = 3.3 V | 3.0 | — | — | |
| Changes in constant output current dependent on V _{DD} | %/V _{DD} | 5 | V _{DD} = 3 V to 5.5 V | — | 1 | 2 | % |
| Supply current | I _{DD} (OFF) 1 | 4 | R-EXT = OPEN, V _{OUT} = 25.0 V | — | — | 1 | mA |
| | I _{DD} (OFF) 2 | 4 | R-EXT = 1.2 kΩ, V _{OUT} = 25.0 V, All channels OFF | — | — | 5 | |
| | I _{DD} (ON) | 4 | R-EXT = 1.2 kΩ, V _{OUT} = 0.4 V, All channels ON | — | — | 9 | |

Switching Characteristics (Unless otherwise specified, Ta = 25°C, V_{DD} = 3 to 3.6 V)

| Characteristics | Symbol | Test Circuit | Test Condition (Note 1) | Min | Typ. | Max | Unit |
|------------------------|-------------------|--------------|--|-----|------|-----|------|
| Propagation delay time | t _{pLH1} | 6 | CLK-OUT _n , LATCH = "H", ENABLE = "L" | — | — | 300 | ns |
| | t _{pLH2} | 6 | LATCH - OUT _n , ENABLE = "L" | — | — | 300 | |
| | t _{pLH3} | 6 | ENABLE - OUT _n , LATCH = "H" | — | — | 300 | |
| | t _{pLH} | 6 | CLK-SERIAL OUT | 2 | — | 14 | |
| | t _{pHL1} | 6 | CLK-OUT _n , LATCH = "H", ENABLE = "L" | — | — | 340 | |
| | t _{pHL2} | 6 | LATCH - OUT _n , ENABLE = "L" | — | — | 340 | |
| | t _{pHL3} | 6 | ENABLE - OUT _n , LATCH = "H" | — | — | 340 | |
| | t _{pHL} | 6 | CLK-SERIAL OUT | 2 | — | 14 | |
| Output rise time | t _{or} | 6 | 10% to 90% points of OUT ₀ to OUT ₇ voltage waveforms | — | — | 150 | |
| Output fall time | t _{of} | 6 | 90% to 10% points of OUT ₀ to OUT ₇ voltage waveforms | — | — | 300 | |

Note 1: T_{opr} = 25°C, V_{DD} = V_{IH} = 3.3 V, V_{IL} = 0 V, R_{EXT} = 1.2 kΩ, I_{OUT} = 15mA, V_L = 5.0 V,
C_L = 10.5pF (see test circuit 6.)

Test Circuits

Test Circuit 1: SERIAL-OUT output voltage (V_{OH}/V_{OL})

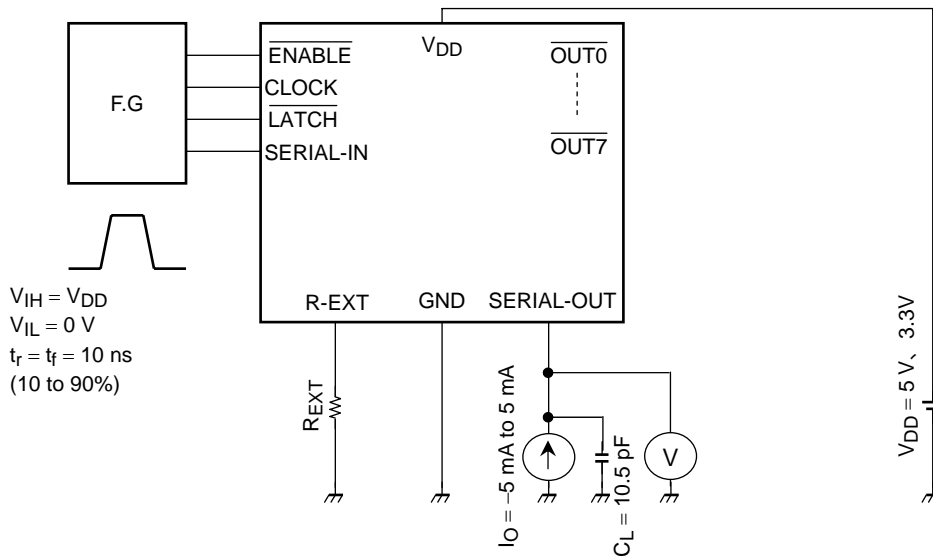

Test Circuit 2: Input Current (I_{IH})

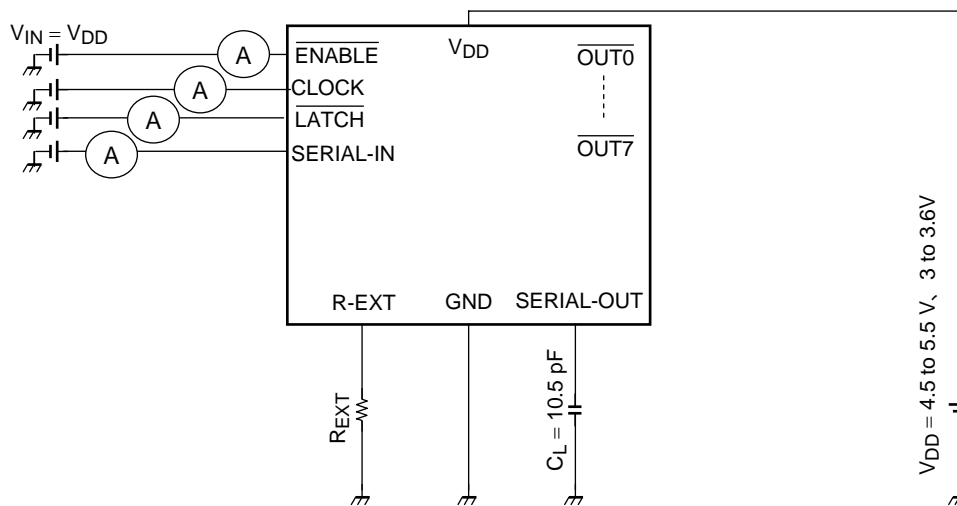

Test Circuit 3: Input Current (I_{IL})

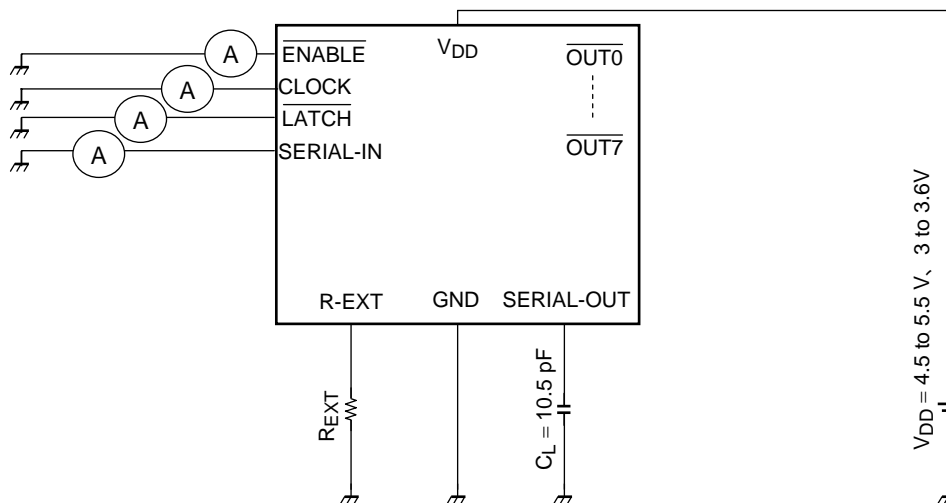

Test Circuit 4: Supply Current

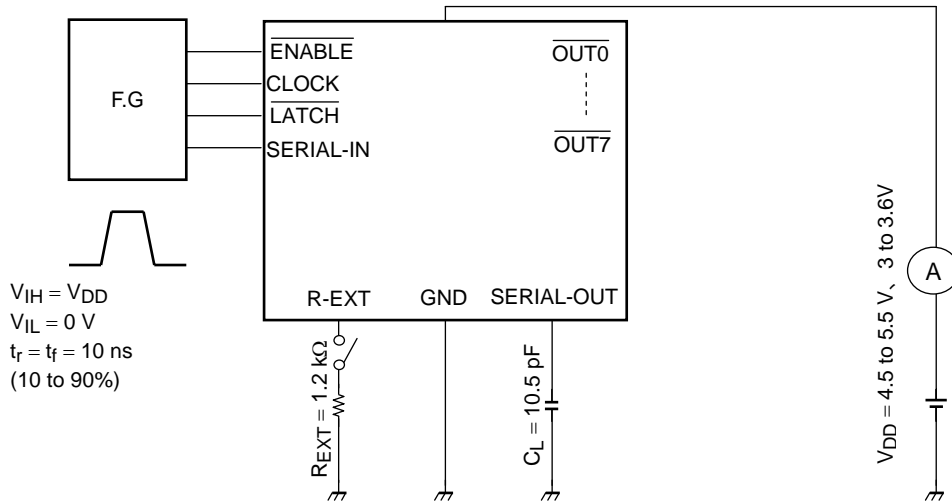

Test Circuit 5: Output Current (I_{OUT1}), Output Leakage Current (I_{OZ}) Output Current Error Margin ($\Delta I_{OUT1}/\Delta I_{OUT2}$), Current Variation with V_{DD} ($\%/V_{DD}$)

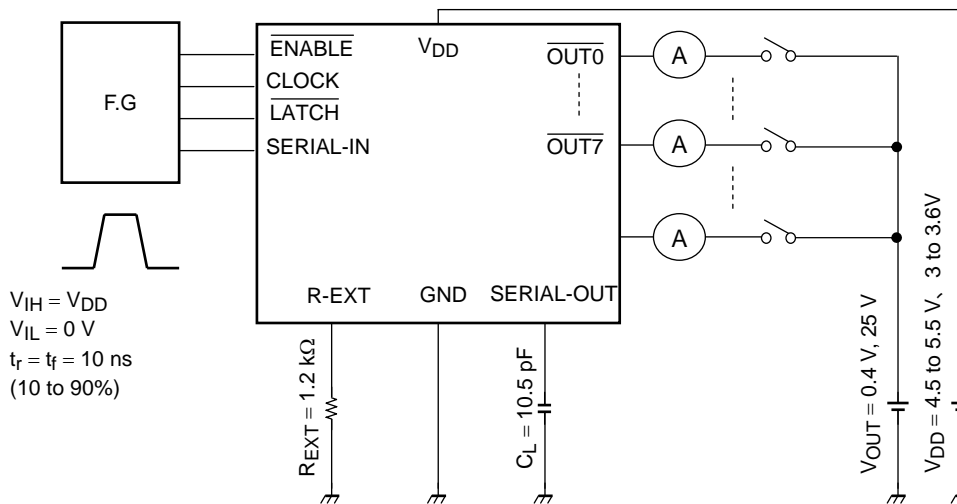

Theoretical output current = $1.13\text{ V}/R_{EXT} \times 16$

Test Circuit 6: Switching Characteristics

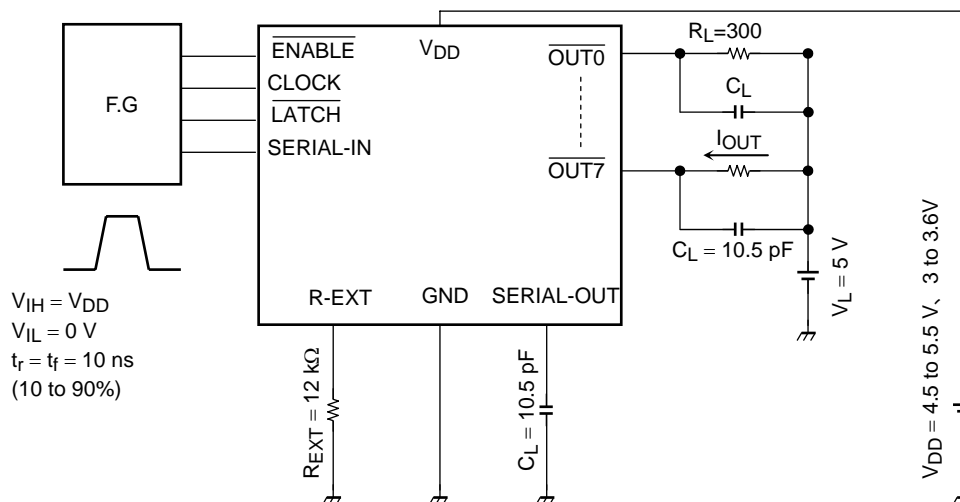

Timing Waveforms

1. CLOCK, SERIAL-IN, SERIAL-OUT

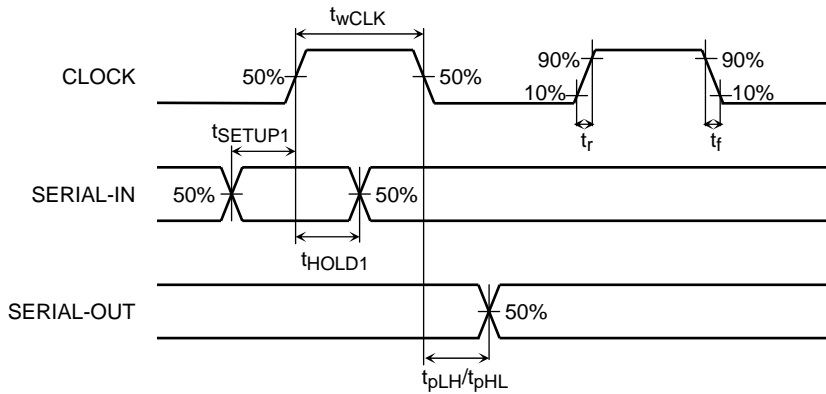

2. CLOCK, SERIAL-IN, LATCH, ENABLE, OUTn

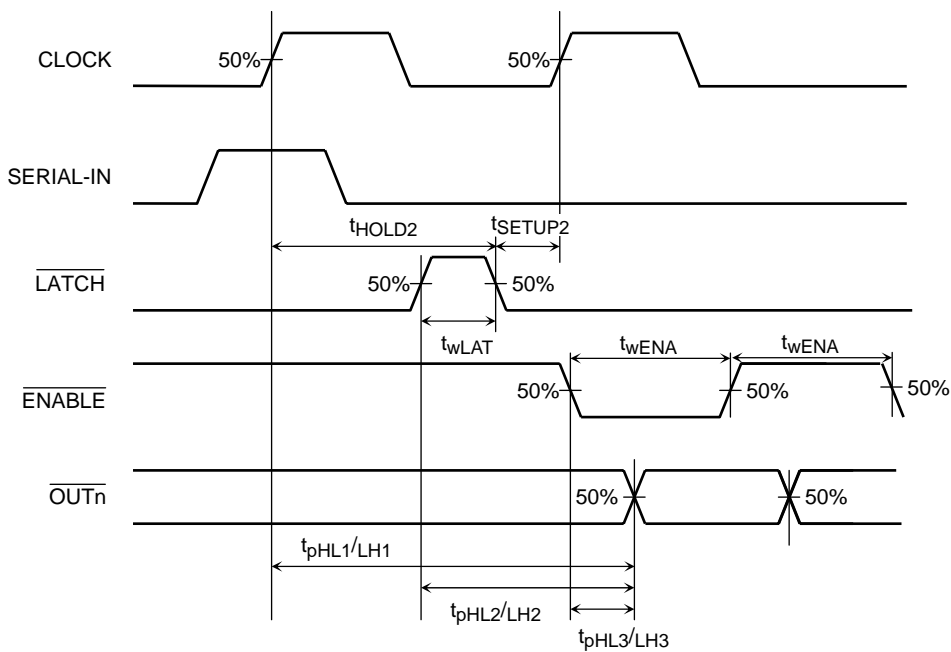

3. OUTn

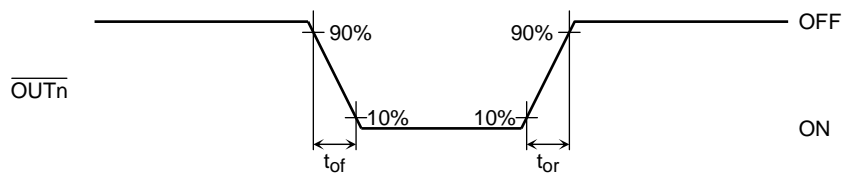

PCB Conditions: 76.2 × 114.3 × 1.6 mm, Cu = 30%, 35- μ m Thick, SEMI-Compliant

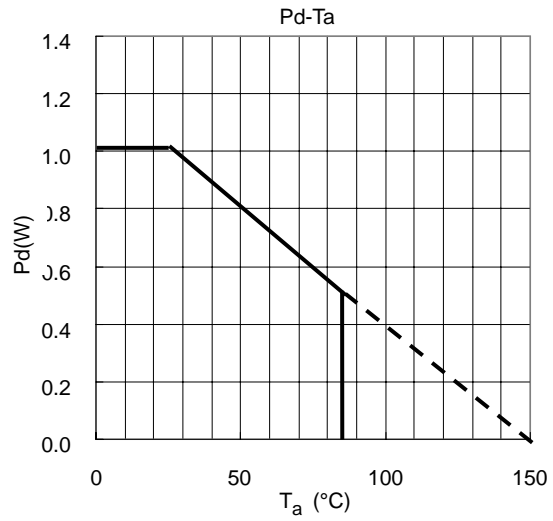
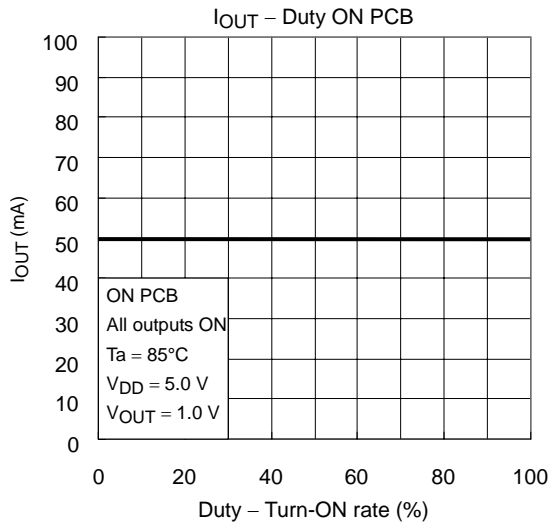

Output Current vs. External Resistor (typ.)

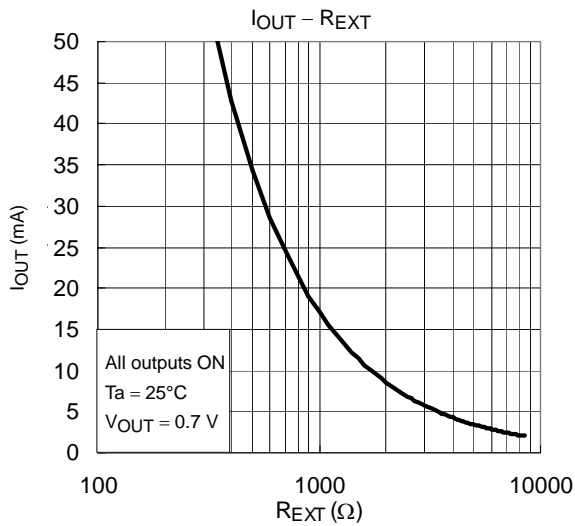

The above graphs are presented merely as a guide and does not constitute any guarantee as to the performance or characteristics of the device. Each product design should be fully evaluated in the real-world environment.

Application Circuit: General Composition for Static Lighting of LEDs

In the following diagram, it is recommended that the LED supply voltage (V_{LED}) be equal to or greater than the sum of V_f (max) of all LEDs plus 0.7 V.

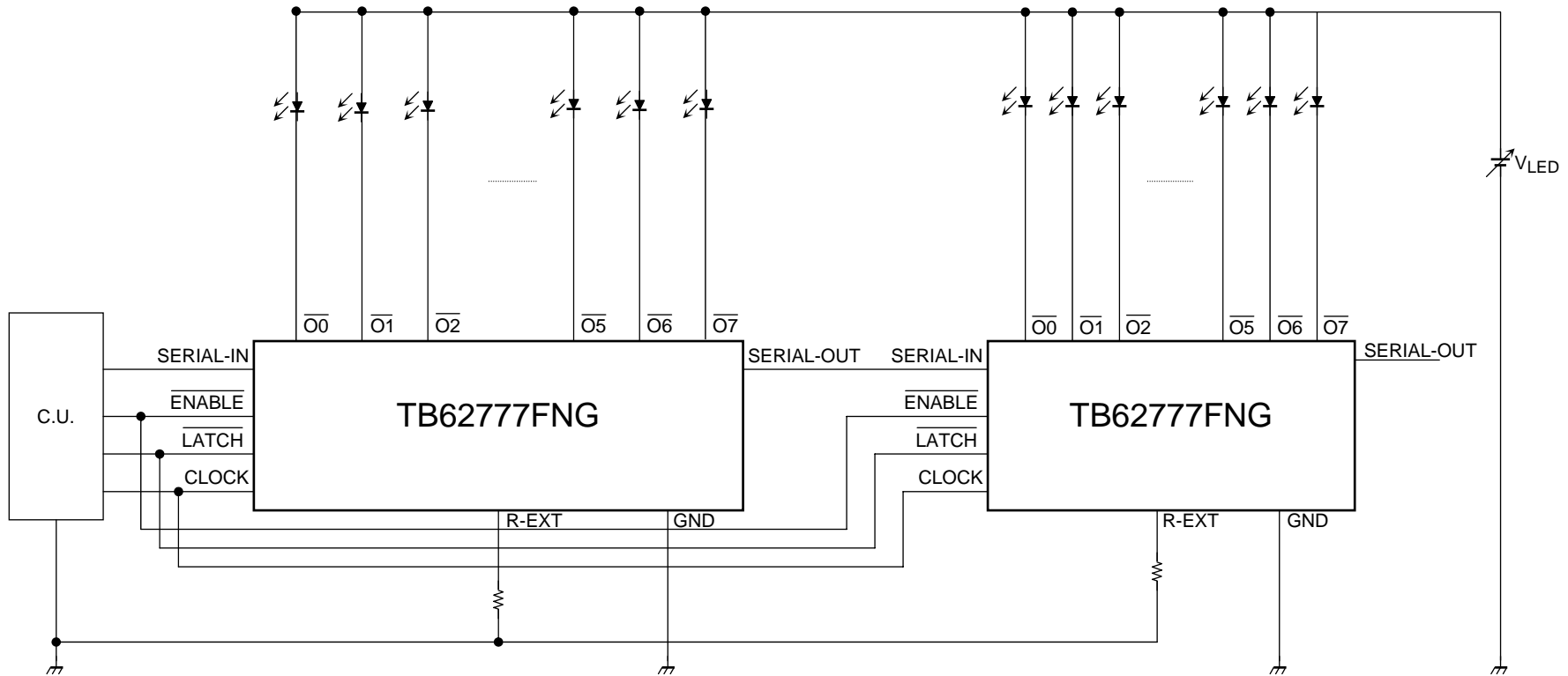

Application Circuit: General Composition for Dynamic Lighting of LEDs

In the following diagram, it is recommended that the LED supply voltage (V_{LED}) be equal to or greater than the sum of V_f (max) of all LEDs plus 0.7 V.

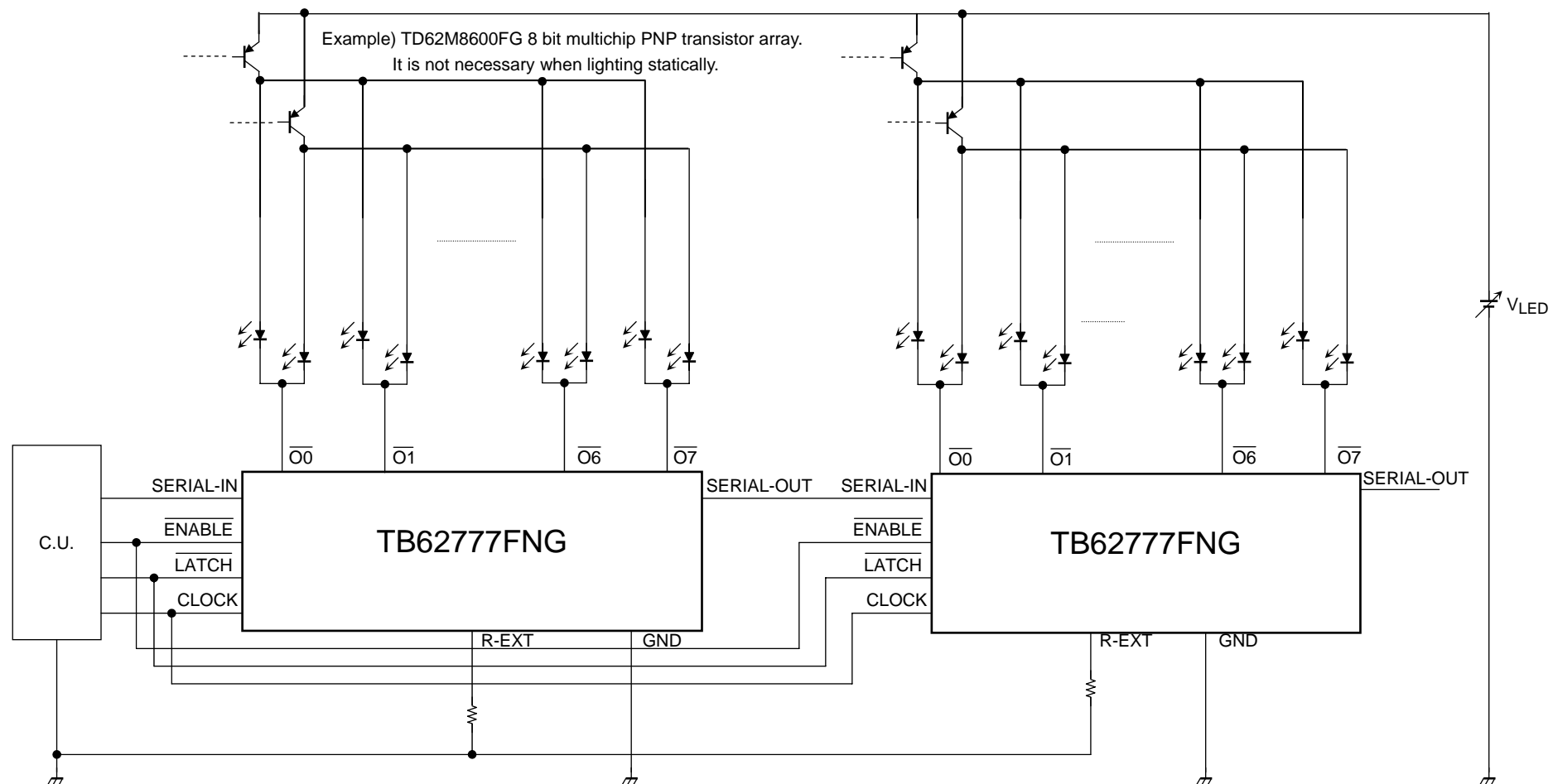

Package Dimensions

SSOP16-P-225-0.65B

Unit : mm

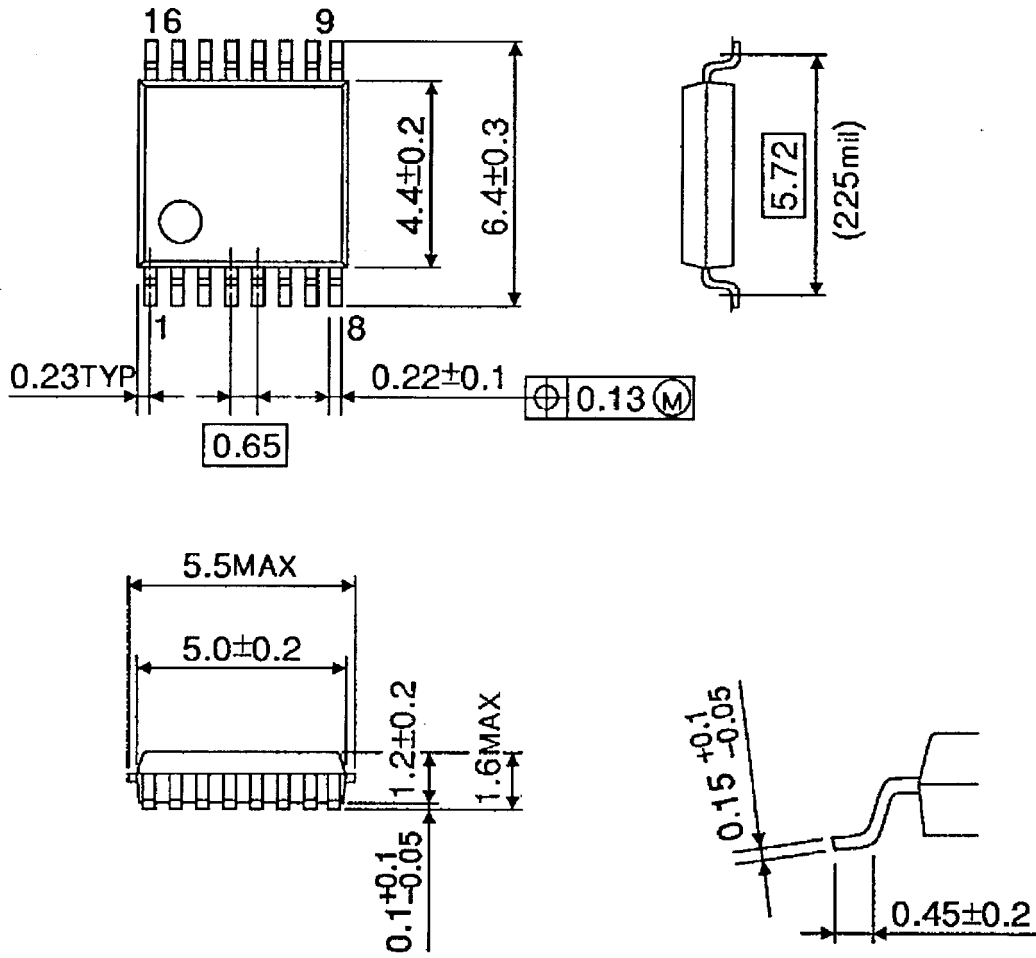

Weight: 0.07 g (typ.)

Notes on Contents

1. Block Diagrams

Some of the functional blocks, circuits, or constants in the block diagram may be omitted or simplified for explanatory purposes.

2. Equivalent Circuits

The equivalent circuit diagrams may be simplified or some parts of them may be omitted for explanatory purposes.

3. Timing Charts

Timing charts may be simplified for explanatory purposes.

4. Application Circuits

The application circuits shown in this document are provided for reference purposes only. Thorough evaluation is required, especially at the mass production design stage.

Toshiba does not grant any license to any industrial property rights by providing these examples of application circuits.

5. Test Circuits

Components in the test circuits are used only to obtain and confirm the device characteristics. These components and circuits are not guaranteed to prevent malfunction or failure from occurring in the application equipment.

IC Usage Considerations

Notes on handling of ICs

- (1) The absolute maximum ratings of a semiconductor device are a set of ratings that must not be exceeded, even for a moment. Do not exceed any of these ratings.
Exceeding the rating(s) may cause the device breakdown, damage or deterioration, and may result injury by explosion or combustion.
- (2) Use an appropriate power supply fuse to ensure that a large current does not continuously flow in case of over current and/or IC failure. The IC will fully break down when used under conditions that exceed its absolute maximum ratings, when the wiring is routed improperly or when an abnormal pulse noise occurs from the wiring or load, causing a large current to continuously flow and the breakdown can lead smoke or ignition. To minimize the effects of the flow of a large current in case of breakdown, appropriate settings, such as fuse capacity, fusing time and insertion circuit location, are required.
- (3) If your design includes an inductive load such as a motor coil, incorporate a protection circuit into the design to prevent device malfunction or breakdown caused by the current resulting from the inrush current at power ON or the negative current resulting from the back electromotive force at power OFF. IC breakdown may cause injury, smoke or ignition.
Use a stable power supply with ICs with built-in protection functions. If the power supply is unstable, the protection function may not operate, causing IC breakdown. IC breakdown may cause injury, smoke or ignition.
- (4) Do not insert devices in the wrong orientation or incorrectly.
Make sure that the positive and negative terminals of power supplies are connected properly. Otherwise, the current or power consumption may exceed the absolute maximum rating, and exceeding the rating(s) may cause the device breakdown, damage or deterioration, and may result injury by explosion or combustion.
In addition, do not use any device that is applied the current with inserting in the wrong orientation or incorrectly even just one time.

- (5) Carefully select external components (such as inputs and negative feedback capacitors) and load components (such as speakers), for example, power amp and regulator.
If there is a large amount of leakage current such as input or negative feedback condenser, the IC output DC voltage will increase. If this output voltage is connected to a speaker with low input withstand voltage, overcurrent or IC failure can cause smoke or ignition. (The over current can cause smoke or ignition from the IC itself.) In particular, please pay attention when using a Bridge Tied Load (BTL) connection type IC that inputs output DC voltage to a speaker directly.

Points to remember on handling of ICs

- (1) Over current Protection Circuit
Over current protection circuits (referred to as current limiter circuits) do not necessarily protect ICs under all circumstances. If the Over current protection circuits operate against the over current, clear the over current status immediately.
Depending on the method of use and usage conditions, such as exceeding absolute maximum ratings can cause the over current protection circuit to not operate properly or IC breakdown before operation. In addition, depending on the method of use and usage conditions, if over current continues to flow for a long time after operation, the IC may generate heat resulting in breakdown.
- (2) Back-EMF
When a motor rotates in the reverse direction, stops or slows down abruptly, a current flow back to the motor's power supply due to the effect of back-EMF. If the current sink capability of the power supply is small, the device's motor power supply and output pins might be exposed to conditions beyond maximum ratings. To avoid this problem, take the effect of back-EMF into consideration in system design.

About solderability, following conditions were confirmed

- Solderability
 - (1) Use of Sn-37Pb solder Bath
 - solder bath temperature = 230°C
 - dipping time = 5 seconds
 - the number of times = once
 - use of R-type flux
 - (2) Use of Sn-3.0Ag-0.5Cu solder Bath
 - solder bath temperature = 245°C
 - dipping time = 5 seconds
 - the number of times = once
 - use of R-type flux

RESTRICTIONS ON PRODUCT USE

20070701-EN

- The information contained herein is subject to change without notice.
- TOSHIBA is continually working to improve the quality and reliability of its products. Nevertheless, semiconductor devices in general can malfunction or fail due to their inherent electrical sensitivity and vulnerability to physical stress. It is the responsibility of the buyer, when utilizing TOSHIBA products, to comply with the standards of safety in making a safe design for the entire system, and to avoid situations in which a malfunction or failure of such TOSHIBA products could cause loss of human life, bodily injury or damage to property.
In developing your designs, please ensure that TOSHIBA products are used within specified operating ranges as set forth in the most recent TOSHIBA products specifications. Also, please keep in mind the precautions and conditions set forth in the "Handling Guide for Semiconductor Devices," or "TOSHIBA Semiconductor Reliability Handbook" etc.
- The TOSHIBA products listed in this document are intended for usage in general electronics applications (computer, personal equipment, office equipment, measuring equipment, industrial robotics, domestic appliances, etc.). These TOSHIBA products are neither intended nor warranted for usage in equipment that requires extraordinarily high quality and/or reliability or a malfunction or failure of which may cause loss of human life or bodily injury ("Unintended Usage"). Unintended Usage include atomic energy control instruments, airplane or spaceship instruments, transportation instruments, traffic signal instruments, combustion control instruments, medical instruments, all types of safety devices, etc.. Unintended Usage of TOSHIBA products listed in this document shall be made at the customer's own risk.
- The products described in this document shall not be used or embedded to any downstream products of which manufacture, use and/or sale are prohibited under any applicable laws and regulations.
- The information contained herein is presented only as a guide for the applications of our products. No responsibility is assumed by TOSHIBA for any infringements of patents or other rights of the third parties which may result from its use. No license is granted by implication or otherwise under any patents or other rights of TOSHIBA or the third parties.
- Please use these products in this document in compliance with all applicable laws and regulations that regulate the inclusion or use of controlled substances. Toshiba assumes no liability for damage or losses occurring as a result of noncompliance with applicable laws and regulations.