

PRELIMINARY
 Notice: This is not a final specification.
 Some parametric limits are subject to change.

MITSUBISHI GATE COMMUTATED TURN-OFF THYRISTOR UNIT

GCU35AA-120

HIGH POWER INVERTER USE
 PRESS PACK TYPE

GCU35AA-120



- Asymmetrical GCU unit
- GCT and Gate driver are connected
- ITQRM Repetitive controllable
 on-state current 3500A
- IT(AV) Average on-state current 1200A
- VDRM Repetitive peak off-state voltage 6000V
- VRRM Repetitive peak reverse voltage 21V

APPLICATION

Inverters, DC choppers, Induction heaters, DC to DC converters.

OUTLINE DRAWING

Dimensions in mm

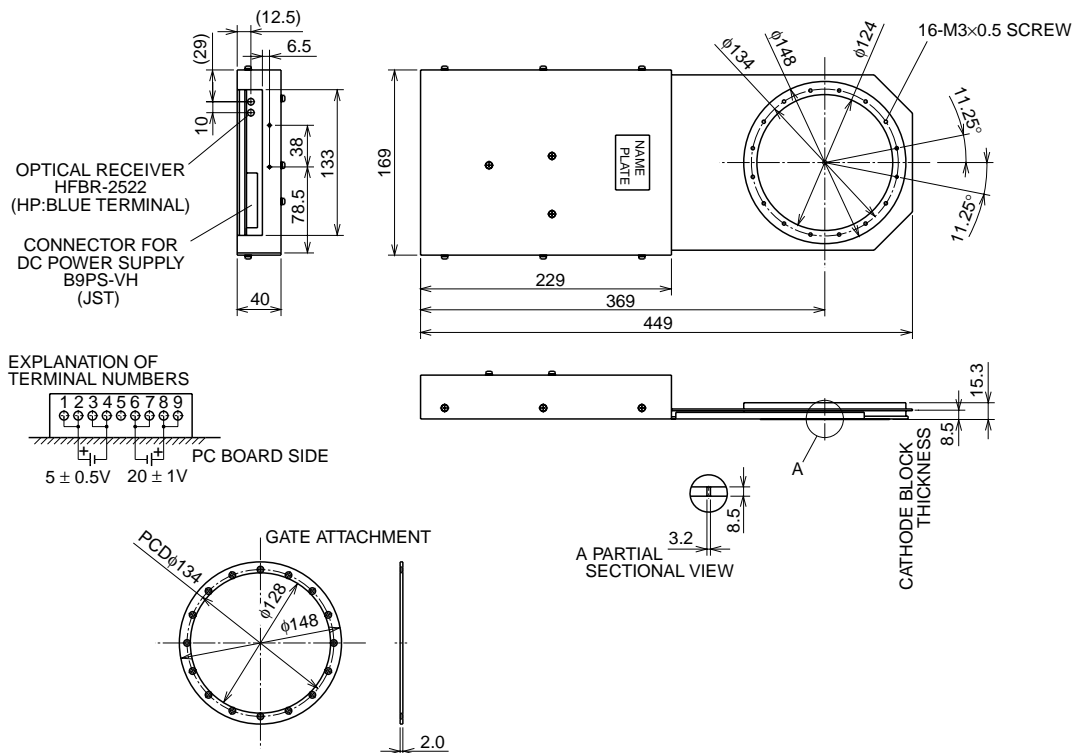

PRELIMINARY
 Notice: This is not a final specification.
 Some parametric limits are subject to change.

GCU35AA-120

**HIGH POWER INVERTER USE
 PRESS PACK TYPE**

GCT PART (Type name : FGC3500AX-120DS)

MAXIMUM RATINGS

Symbol	Parameter	Conditions	Voltage class	Unit
VRRM	Repetitive peak reverse voltage	—	21	V
VRSM	Non-repetitive peak reverse voltage	—	21	V
VDRM	Repetitive peak off-state voltage	VGK = -2V	6000	V
VD SM	Non-repetitive peak off-state voltage	VGK = -2V	6000	V
VL TDS	Long term DC stability voltage	VGK = -2V, λ = 100 Fit	3600	V

Symbol	Parameter	Conditions	Ratings	Unit
IT QRM	Repetitive controllable on-state current	VDM = 6000V, VD = 3600V, VRG = 20V, LC = 0.3μH Tj = 25/125°C, With GU-C40 (see Fig. 1, 3)	3500	A
IT (RMS)	RMS on-state current	Applied for all condition angles	1800	A
IT (AV)	Average on-state current	f = 60Hz, sinewave θ = 180°, Tf = 70°C	1200	A
IT SM	Surge on-state current	One half cycle at 60Hz, Tj = 125°C Start	25	kA
I ² t	Current-squared, time integration		2.6 × 10 ⁶	A ² s
diT/dt	Critical rate of rise of on-state current	VD = 3600V, IT = 3500A, Tj = 25/125°C, f = 60Hz With GU-C40 (see Fig. 1,2)	1000	A/μs
VFGM	Peak forward gate voltage		10	V
VRGM	Peak reverse gate voltage		21	V
IFGM	Peak forward gate current		1000	A
IRGM	Peak reverse gate current		3500	A
PFGM	Peak forward gate power dissipation		10	kW
PRGM	Peak reverse gate power dissipation		120	kW
PFG(AV)	Average forward gate power dissipation		200	W
PRG(AV)	Average reverse gate power dissipation		630	W
Tj	Operation junction temperature		-20 ~ +125	°C
Tstg	Storage temperature		-20 ~ +150	°C
—	Mounting force required	(Recommended value 40kN)	32 ~ 48	kN
—	Weight	Typical value	1500	g

ELECTRICAL CHARACTERISTICS

Symbol	Parameter	Conditions	Limits			Unit
			Min	Typ	Max	
V _{TM}	On-state voltage	IT = 3500A, Tj = 125°C	—	—	3.8	V
I _{RRM}	Repetitive peak reverse current	VRM = 21V, Tj = 125°C	—	—	100	mA
I _{DRM}	Repetitive peak off-state current	VDM = 6000V, VGK = -2V, Tj = 125°C	—	—	150	mA
I _{G RM}	Reverse gate current	VRG = 21V, Tj = 125°C	—	—	100	mA
dv/dt	Critical rate of rise of off-state voltage	VD = 3600V, VGK = -2V, Tj = 125°C (Expo. wave)	3000	—	—	V/μs
t _{gt}	Turn-on time	VD = 3600V, IT = 3500A, di/dt = 1000A/μs, Tj = 125°C With GU-C40 (see Fig. 1, 2)	—	—	3.0	μs
t _d	Turn-on delay time		—	—	1.0	μs
E _{on}	Turn-on switching energy		—	1.2	—	J/P
t _s	Storage time	VDM = 6000V, VD = 3600V, IT = 3500A VRG = 20V, Tj = 125°C	—	—	3.0	μs
E _{off}	Turn-off switching energy	With GU-C40 (see Fig. 1, 3)	—	19	—	J/P
I _{GT}	Gate trigger current	VD = 24V, RL = 0.1Ω, Tj = 25°C	—	—	2.5	A
V _{GT}	Gate trigger voltage	DC method	—	—	1.5	V
R _{th(j-f)}	Thermal resistance	Junction to Fin	—	—	0.011	K/W

PRELIMINARY
 Notice: This is not a final specification.
 Some parametric limits are subject to change.

GCU35AA-120

**HIGH POWER INVERTER USE
 PRESS PACK TYPE**

GATE DRIVER PART (Type name : GU-C40)

Symbol	Parameter	Conditions	Limits			Unit
			Min	Typ	Max	
+Vc	Power supply (+) (Note 1, 3)	DC power supply 10A	4.5	5.0	5.5	V
-Vc	Power supply (-) (Note 2, 3)	DC power supply 6A	19	20	21	V
—	Control signal	Optical fiber data link Transmitter : HFBR-1522 (HP) Receiver : HFBR-2522 (HP)	—	—	—	—
f	Frequency	IT = 1500Arms, duty = 0.5	—	—	500	Hz
ton min	Turn-on minimum (Note 4)	Protection is 28 μs min and 32 μs max.	28	30	32	μs
toff min	Turn-off minimum (Note 5)	Protection is 44 μs min and 52 μs max.	44	50	52	μs
tfd	Delay time of on gate current	Ta = 25°C	7	8	9	μs
trd	Delay time of off gate current	Ta = 25°C	5	6	7	μs
diG/dt	Critical rate of rise of on gate current		100	—	—	A/μs
IGM	Peak on gate current		—	200	—	A
tw	Width of on high gate current		5	—	—	μs
IG	On gate current		10	—	—	A
diGQ/dt	Critical rate of rise of off gate current	VRG = 20V	—	6000	—	A/μs
Dmax	Maximum duty		—	—	50	%
—	Weight	With FGC3500AX-120DS	—	4600	—	g
Ta	Temperature	Operation temperature (Recommend : ≤ 40°C)	-10	—	+60	°C
Rth	Thermal resistance (Junction to Fin) (Note 6)	With FGC3500AX-120DS	—	—	0.012	K/W

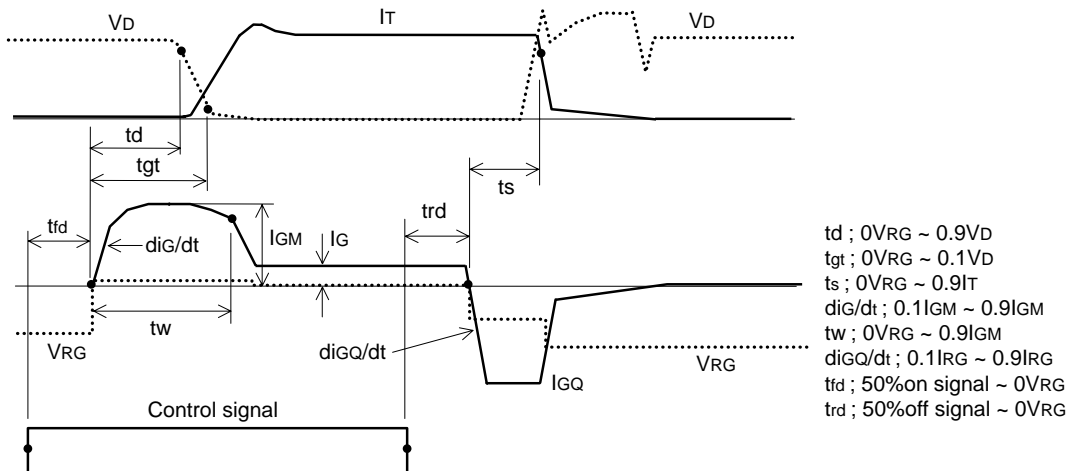

Fig. 1 Turn-on and Turn-off waveform

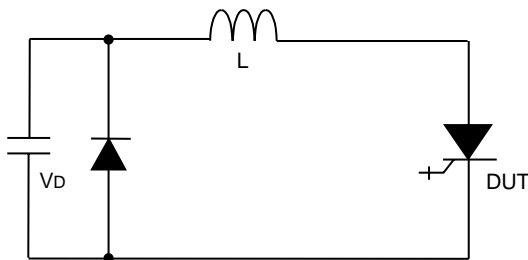
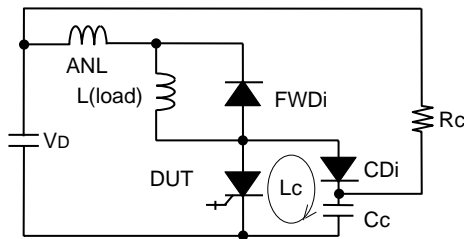

Fig. 2 Turn-on test circuit



**Fig. 3 Turn-off test circuit
 (With clamp circuit)**

PRELIMINARY
 Notice: This is not a final specification.
 Some parametric limits are subject to change.

GCU35AA-120

**HIGH POWER INVERTER USE
 PRESS PACK TYPE**

- Note 1. In case of DC power supply which has no current control, please be careful that rush current (peak value 140A, width 2ms) flows at the turn on of power supply in 1m cable for power supply.
- Note 2. In case of DC power supply which has no current control, please be careful that rush current (peak value 250A, width 2ms) flows at the turn on of power supply in 1m cable for power supply.
- Note 3. Main current condition of GCT Thyristor is 1500Arms and duty = 0.5.
- Note 4. If input turn-on signal is shorter than $t_{on}(min)$, protection operates and turn on width is $28\mu s$ min and $32\mu s$ max.
- Note 5. If turn-on signal is input during $t_{off}(min)$, protection operates and turn off width is $44\mu s$ min and $52\mu s$ max.
- Note 6. If GU-C40 and FGC3500AX-120DS are used together, $R_{th(j-f)}$ becomes 0.012K/W.
 (Only FGC3500AX-120DS is used, $R_{th(j-f)}$ becomes 0.011K/W)

Fig. 4 Connection instruction for the gate

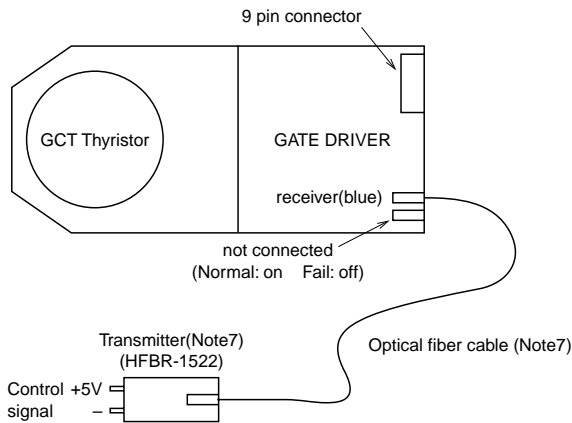

**Fig. 5 9pin connector and cable (VHR-9N)
 (Note 7., 8.)**

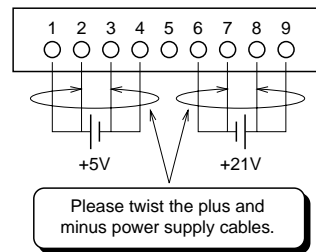

- Note 7. Please prepare these parts beforehand.
- Note 8. A cross section of power supply cable is $0.75mm^2$ or $0.83mm^2$ and twist the positive and ground cable. The power supply cable is shorter than 2m and lower inductance.

PRELIMINARY
 Notice: This is not a final specification.
 Some parametric limits are subject to change.

GCU35AA-120

**HIGH POWER INVERTER USE
 PRESS PACK TYPE**

PERFORMANCE CURVES

MAXIMUM ON-STATE CHARACTERISTIC

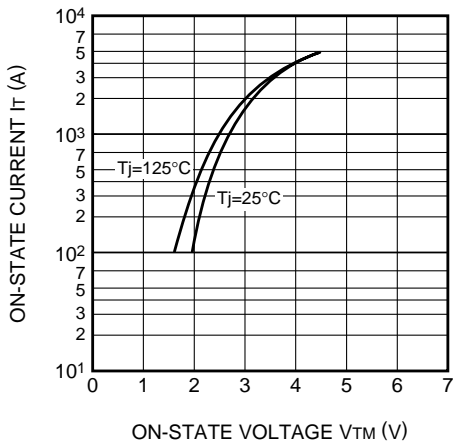

**E_{on} VS I_T
 (TYPICAL)**

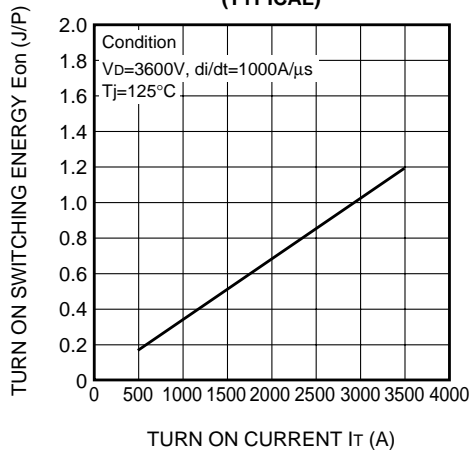

**E_{off} VS I_T
 (TYPICAL)**

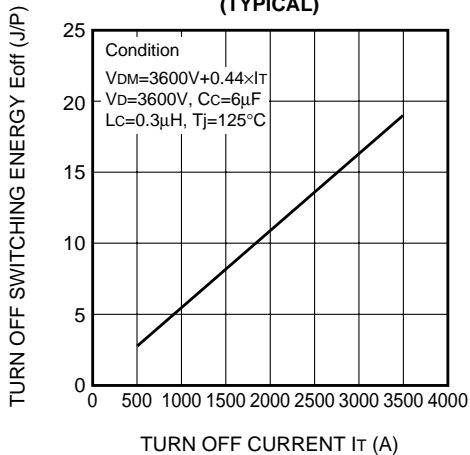

**MAXIMUM THERMAL IMPEDANCE
 CHARACTERISTIC
 (JUNCTION TO FIN)**

