

Advanced Lithium-Ion Linear Battery Charger

General Description

The RT9501 is a single Lithium-Ion or Lithium-Polymer cell linear battery charger which is designed for compact and cost-sensitive handheld devices. It combines charge status indication, charge termination, battery temperature monitoring, and high accuracy current and voltage regulation in a MSOP-8 package.

The RT9501 charges the battery in three modes, precharge, constant current, constant voltage. If the battery voltage is below the precharge threshold $V_{O(MIN)}$, the RT9501 precharges the battery with a lower conditioning current. After precharge, the RT9501 applies a constant current to the battery. An external sense-resistor sets the charge current. The constant voltage mode continues until the battery reaches the regulation voltage.

The battery temperature is continuously measured by an external thermistor through the TS pin. The RT9501 inhibits charge until the temperature is within the range defined by users.

Ordering Information

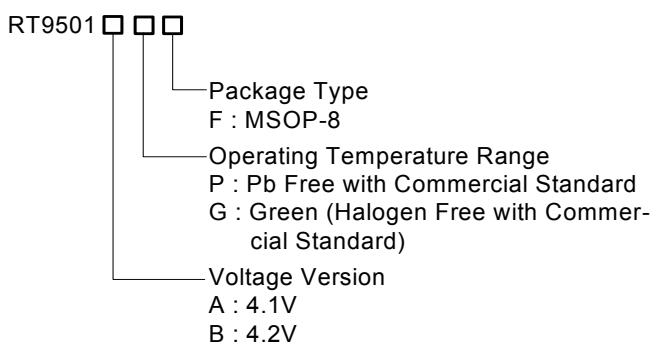

Note :

RichTek Pb-free and Green products are :

- ▶RoHS compliant and compatible with the current requirements of IPC/JEDEC J-STD-020.
- ▶Suitable for use in SnPb or Pb-free soldering processes.
- ▶100%matte tin (Sn) plating.

Features

- For Single Lithium-Ion or Lithium-Polymer Cell Battery Pack (4.1V or 4.2V)
- A Few External Components are Required
- Precharge, Constant Current, Constant Voltage Modes
- Battery Temperature Monitor
- Charge Status Indication
- Automatic Battery Recharge
- Charge Termination Detect
- Auto Low Power Sleep Mode when VDD Power is Removed
- MSOP-8 Package
- RoHS Compliant and 100% Lead (Pb)-Free

Applications

- Digital Cameras
- PDAs
- Cellular Phones
- Information Appliance

Marking Information

For marking information, contact our sales representative directly or through a RichTek distributor located in your area, otherwise visit our website for detail.

Pin Configurations

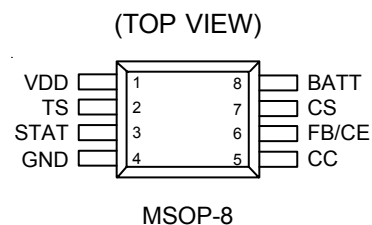

Typical Application Circuit

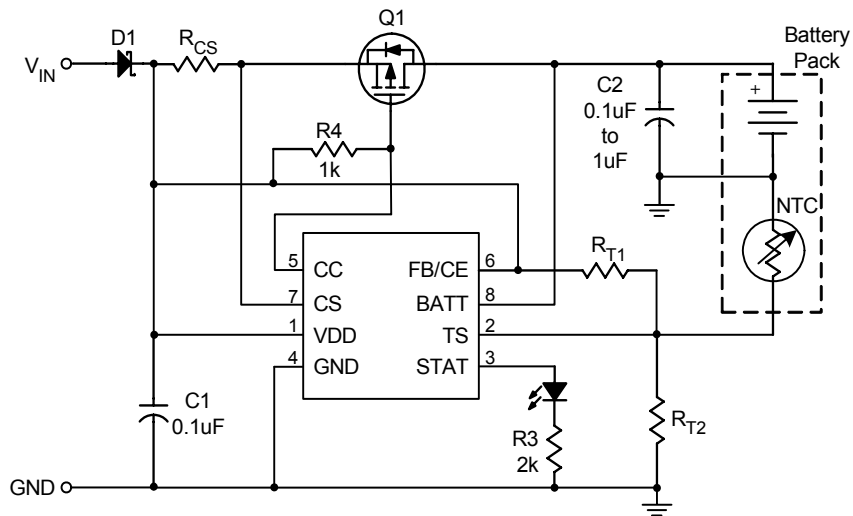

Figure 1. Application circuit using P-Channel MOSFET

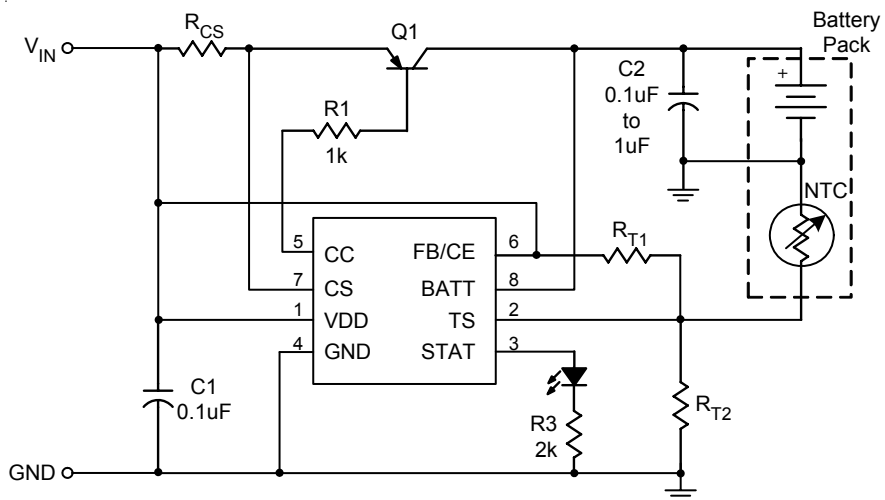
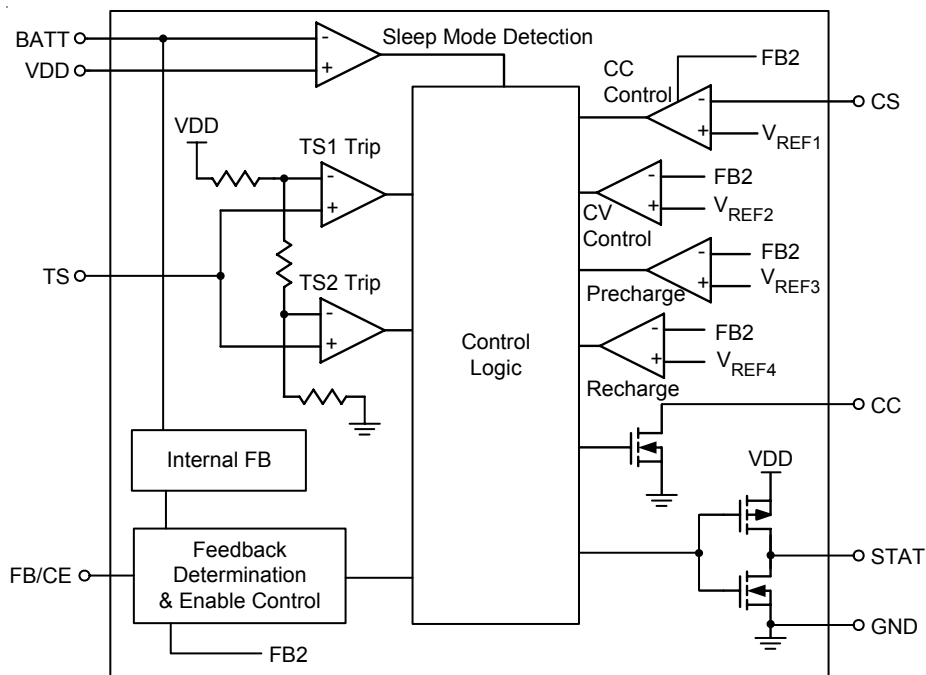

Figure 2. Application circuit using PNP transistor

Functional Pin Description

Pin Name	Pin Function
VDD	Supply Voltage Input.
TS	Temperature Sense Input. Input from battery temperature monitoring circuit.
STAT	Charge Status Output. 3-state status indication of charge, charge complete and temperature fault or disable or sleep mode.
GND	Ground.
CC	Charge Control Output. Current output to drive on external PNP transistor or P-Channel MOSFET for current and voltage regulation.
FB/CE	External Feedback Input or Charge Enable Function. Input from controller or finely adjust the battery regulated voltage with external voltage divider.
CS	Current Sense Input. Charge current is sensed according to the voltage drop from supply voltage to this pin.
BATT	Battery Voltage input. Input directly from battery voltage.

Function Block Diagram



Absolute Maximum Ratings (Note 1)

- Supply Voltage ----- -0.3V to 7V
- Storage Temperature Range ----- -65°C to 150°C
- Power Dissipation, P_D @ T_A = 25°C
 - MSOP-8 ----- 300mW
- Package Thermal Resistance
 - MSOP-8, θ_{JA} ----- 80°C/W
- Operation Junction Temperature Range ----- -40°C to 125°C
- Junction Temperature ----- 150°C
- ESD Susceptibility (Note 2)
 - HBM (Human Body Mode) ----- 2kV
 - MM (Machine Mode) ----- 200V

Recommended Operating Conditions (Note 3)

- Supply Input Voltage ----- 4.5V to 7V
- Junction Temperature Range ----- -20°C to 70°C

Electrical Characteristics

(T_A = 25°C, unless otherwise specification)

Parameter	Symbol	Test Condition	Min	Typ	Max	Units
Operating Current	I _{DD(OPE)}	4.5V < V _{DD} < 7V, Excluding external loads	--	1	2	mA
V _{DD} Sleep Current	I _{DD(SLP)}	V _{BATT} - V _{DD} ≥ 0.2V	--	--	3	µA
Input Bias Current @ BATT pin	I _{BATT}	V _{BATT} = V _{O(REG)} , V _{BATT} - V _{DD} ≥ 0.2V	--	1.5	2.5	µA
Input Bias Current @ CS pin	I _{CS}	V _{CS} = 5V, V _{BATT} - V _{DD} ≥ 0.2V	--	--	1	µA
Input Bias Current @ TS pin	I _{TS}	V _{TS} = 5V, V _{BATT} - V _{DD} ≥ 0.2V	--	--	1	µA
Input Bias Current @ FB/CE pin	I _{CE}	V _{CE} = 5V, V _{BATT} - V _{DD} ≥ 0.2V	--	--	1	µA
Input Low Voltage @ CE pin	V _{CE}		--	--	1.5	V
Input High Voltage @ CE pin	V _{CE}		V _{DD} -1.5	--	--	V
Feedback Voltage @ FB pin	V _{FB}		2.048	2.10	2.152	V
Output Voltage	V _{O(REG)}	RT9501A	4.059	4.10	4.141	V
		RT9501B	4.158	4.20	4.242	V
Current Regulation Threshold	V _{I(SNS)}	V _{I(SNS)} = V _{DD} - V _{CS}	100	110	121	mV
Charge Terminated Current Detect Threshold	V _(TERM)		2	12	22	mV
Lower Temperature Threshold	V _{TS1}		29.1	30	30.9	%V _{DD}
Upper Temperature Threshold	V _{TS2}		58.3	60	61.8	%V _{DD}
Precharge Threshold	V _{O(MIN)}		2.8	2.9	3.0	V
Precharge Current Regulation	V _(PRE)		4	14	24	mV
Recharge Threshold	V _{O(RCH)}		V _{O(REG)} - 140mV	V _{O(REG)} - 100mV	V _{O(REG)} - 60mV	V

To be continued

Parameter	Symbol	Test Condition	Min	Typ	Max	Units
Output (Low) Voltage @ STAT pin	$V_{STAT(LOW)}$	$I_{OL} = 10mA$	--	0.4	0.6	V
Output (High) Voltage @ STAT pin	$V_{STAT(HIGH)}$	$I_{OH} = 5mA$	$V_{DD}-0.5$	--	--	
Output Low Voltage @ CC pin	$V_{CC(LOW)}$	$I_{O(CC)} = 5mA$ (sink)	--	--	1.5	V
Sink current @ CC pin	$I_{CC(SINK)}$	Not to exceed power rating specification (PD)	5	--	40	mA

Note 1. Stresses listed as the above "Absolute Maximum Ratings" may cause permanent damage to the device. These are for stress ratings. Functional operation of the device at these or any other conditions beyond those indicated in the operational sections of the specifications is not implied. Exposure to absolute maximum rating conditions for extended periods may remain possibility to affect device reliability.

Note 2. Devices are ESD sensitive. Handling precaution recommended.

Note 3. The device is not guaranteed to function outside its operating conditions.

Application Information

Charge Profile

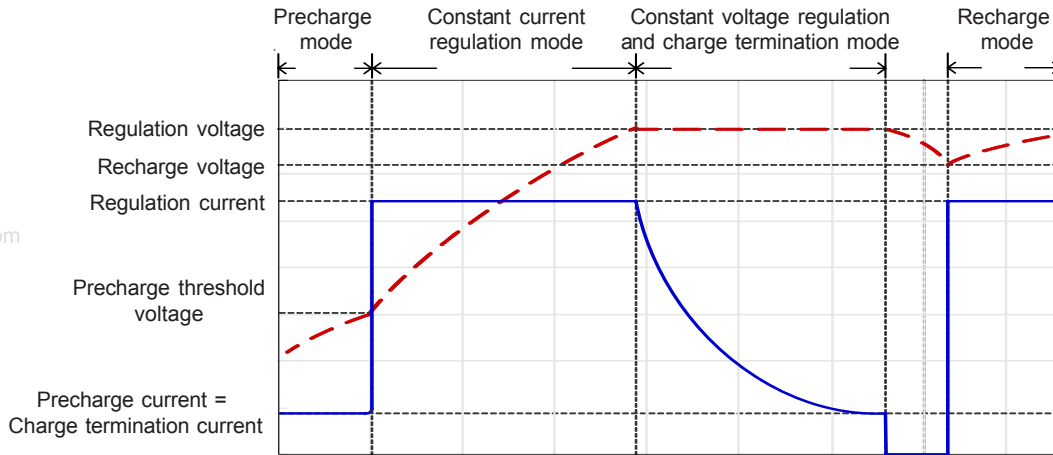

Figure 3. Typical charge profile

Detection

First, the FB/CE pin must connect to VDD or a voltage divider to enable the charge function. And then if a battery is already inserted and the input power source is absent, the RT9501 will enter sleep mode to prevent draining power from battery. When input power source and battery are both existed, another detection is the battery temperature. The TS pin voltage must be in the allowed range as shown in Figure 6 and the electrical characteristics, and then the RT9501 will start the charge cycle according to the battery voltage conditions.

Precharge Mode

When the battery voltage is lower than the precharge threshold $V_{O(MIN)}$, the RT9501 begins to charge the battery in precharge mode. In this condition, the precharge current is set at approximately 10% of the constant regulation current. The purposes of small precharge current are to minimize the power dissipation on the external switch during the precharge period and to revive deeply discharged battery cells.

Constant Current Regulation Charge Mode

When the battery voltage is between the precharge threshold $V_{O(MIN)}$ and the regulation voltage $V_{O(REG)}$, the RT9501 starts the constant current regulation charge mode. RT9501 monitors charge current with voltage drop between two terminals of a sense-resistor, R_{CS} , which connects to pin VDD and CS. The following equation can calculate the desired charging current.

$$I_{O(REG)} = \frac{V_{I(SNS)}}{R_{CS}}$$

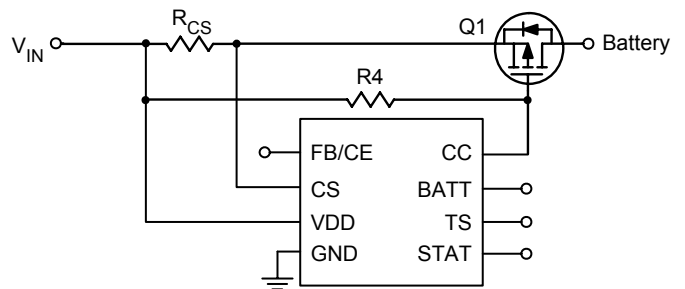

Figure 4

Constant Voltage Regulation and Charge Termination Mode

When the battery voltage reaches the regulation voltage $V_{O(REG)}$, the constant voltage feedback control starts, and then the charge current begins to decrease as the typical charge profile shown. As the charge current decreases to lower than charge terminated current threshold, the RT9501 will terminate the charge cycle.

Recharge Mode

After the charge termination mode, if the battery voltage falls to lower than the recharge threshold voltage $V_{O(RCH)}$, the RT9501 will begin a new charge cycle according to the battery voltage.

Battery Temperature Detection

The RT9501 continuously detects the battery temperature by measuring the TS pin voltage. A NTC or PTC thermistor can parallel with R_{T2} to deviate the TS pin voltage. (As shown in Figure 5) The TS pin voltage must be within normal temperature voltage range that is shown in Figure 6 and electrical characteristics, and then RT9501 can start working normally.

The R_{T1} and R_{T2} can be derived from following equations.

For NTC Thermistors:

$$R_{T1} = \frac{5 \times R_{TH} \times R_{TL}}{3 \times (R_{TL} - R_{TH})}$$

$$R_{T2} = \frac{5 \times R_{TH} \times R_{TL}}{[(2 \times R_{TL}) - (7 \times R_{TH})]}$$

For PTC Thermistors:

$$R_{T1} = \frac{5 \times R_{TH} \times R_{TL}}{3(R_{TH} - R_{TL})}$$

$$R_{T2} = \frac{5 \times R_{TH} \times R_{TL}}{[(2 \times R_{TH}) - (7 \times R_{TL})]}$$

Where R_{TL} is the resistance value in lowest desired operation temperature and R_{TH} is the resistance value in highest desired operation temperature. The resistances of thermistors are specified by the thermistor manufacturer. If the temperature monitoring function is not desired, there's an easy method to set R_{T1} and R_{T2} at the same value and disconnect the thermistor to disable this function.

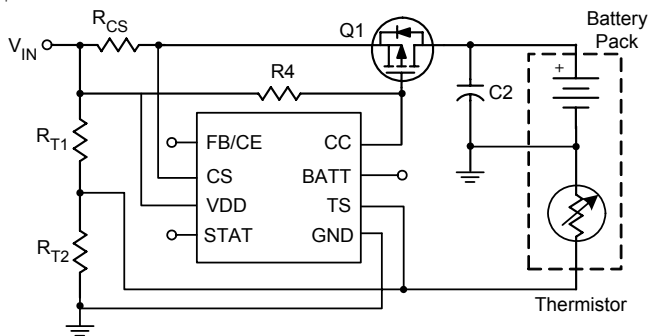

Figure 5

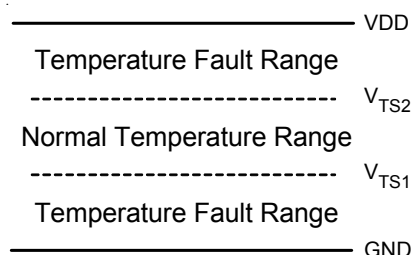

Figure 6

FB/CE Pin Functions

This pin has two functions, one is to enable/disable the charge function, and the other is to finely adjust battery regulation voltage. Connect this pin to VDD to enable RT9501, and connect to ground to disable it (Figure 7). If this pin is connected to a voltage divider as shown in Figure 8, it can be a 2.1V reference voltage to adjust the output regulation voltage as desired.

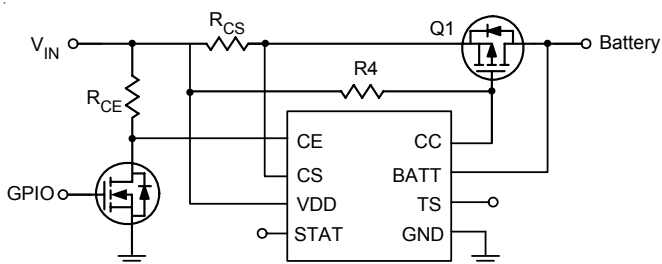

Figure 7. For CE pin Function

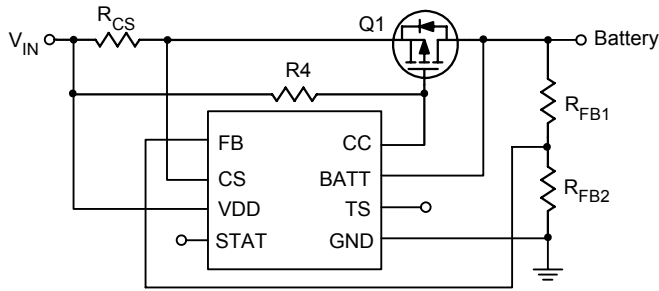

Figure 8. For FB pin Function

$$V_{O(REG)} = 2.1 \times \left(1 + \frac{R_{FB1}}{R_{FB2}}\right) V$$

Charge status indication

The RT9501 indicates the status of the charger on the 3-state STAT pin. The following table shows the statuses of this pin.

Condition	STAT Pin
In battery charging cycle	High
Charge cycle completed	Low
Temperature fault or charge function disable or sleep mode	High Impedance

Selecting an External PNP Pass-Transistor or P-Channel MOSFET:

The RT9501 drives an external PNP transistor or P-Channel MOSFET to control the charging current. The specifications must be concerned are the voltage and current rating and package power dissipation. The external switch is performed as a linear regulator. The maximum power loss occurs when the constant current regulation starts at the beginning, and it can be calculated approximately from following equation:

$$P_{D(MAX)} = I_{(SNS)} \times (V_{DD} - 0.1V - 2.8V)$$

I(SNS) is the constant regulation current.

The minimum voltage drop between the sense-resistor is 100mV, and the minimum precharge threshold voltage is 2.8V.

The external pass device with PCB heatsinking must be rated for the maximum power dissipation.

Selecting Input/Output Capacitor

In analog circuit applications, to place a high-frequency decoupling capacitor nearby the controller IC between input power source and ground is very important. A 0.1uF ceramic is recommended. If a high ripple and noise input power is chosen, it should have enough capacitance to reduce the disturbance.

A 0.1uF to 1uF output capacitor is recommended to control the output voltage and keep the output voltage ripple small when the battery is disconnected.

Outline Dimension

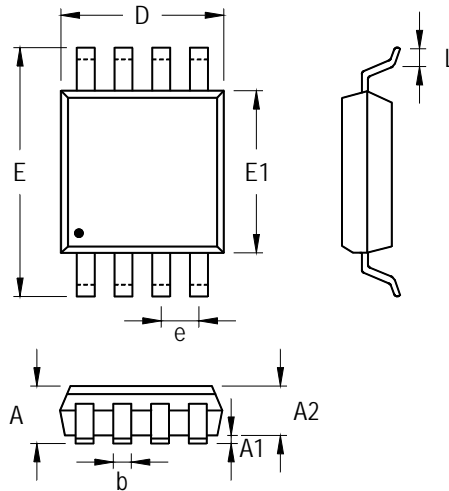

www.DataSheet4U.com

Symbol	Dimensions In Millimeters		Dimensions In Inches	
	Min	Max	Min	Max
A	0.810	1.100	0.032	0.043
A1	0.000	0.150	0.000	0.006
A2	0.750	0.950	0.030	0.037
b	0.220	0.380	0.009	0.015
D	2.900	3.100	0.114	0.122
e	0.650		0.026	
E	4.800	5.000	0.189	0.197
E1	2.900	3.100	0.114	0.122
L	0.400	0.800	0.016	0.031

8-Lead MSOP Plastic Package

Richtek Technology Corporation

Headquarter
 5F, No. 20, Taiyuen Street, Chupei City
 Hsinchu, Taiwan, R.O.C.
 Tel: (8863)5526789 Fax: (8863)5526611

Richtek Technology Corporation

Taipei Office (Marketing)
 8F, No. 137, Lane 235, Paochiao Road, Hsintien City
 Taipei County, Taiwan, R.O.C.
 Tel: (8862)89191466 Fax: (8862)89191465
 Email: marketing@richtek.com