

## ***ML1001 Series Static LCD COG Driver***

### **❖ *Application***

- ◆ *Instrument LCD Module*
- ◆ *Telephone LCD Module*
- ◆ *Automotive LCD Module*
- ◆ *Handheld Device LCD Module*

### **❖ *Features***

- A Gold Bump Chip without external component.
- Logic & LCD power supply: 2.0V to 6.0V
- Typical Current consumption: 25uA at  $V_{IN} = 3V$  & no load condition.
- Number of segments: 40
- Cascade the ML1001 to form a single piece of 80 or 120 segments LCD driver.
- Simple 3 pin microcontroller interface through DIN, DCLK & LOAD.
- Blink of the display data.
- Offer best contrast and widest viewing angle of TN LCD technology.
- No temperature compensation needed for  $T_{opr} = -40^{\circ}C$  to  $80^{\circ}C$ .

### **❖ *General Description***

ML1001 static LCD COG (chip on glass) driver is 40 segments LCD driver with gold bump. It can be cascaded to form a single piece of 80 or 120 segments LCD drivers. It targets at custom TN LCD COG Module product which requires the best quality of TN LCD technology. With the use of ML1001 series driver, it offers the best contrast, the widest viewing angle, the widest range of operating voltage and the widest range of operating temperature when compared to the multiplex method.

Our ML1001 includes an internal 32kHz oscillator, a 40-bit shift register, a 40-bit data register, a 16-bit segment driver, a 24-bit segment driver, two common drivers, a blink control circuit, a power-up reset circuit and a frequency divider which offer the necessary clock signals for Blink control, segment & common driver circuit.

Through the DIN pin, the display data is serially shifted into the 40-bit shift register at the rising edge of DCLK signal. The display data, which is going to be displayed on the attached LCD, is then stored in the 40-bit data register at the rising edge of the LOAD signal.

Other features like blinking of the display data by the BEN and BCLK, disable the internal oscillator by the OEN, input an external clock signal to the FIN, and enable or disable the segment and common driver by the SEN1, SEN2, CEN1A and CEN1B, are included.

### **❖ *Ordering Information***

Part Number	Description	Package Form
ML1001-1U	a 40 segment static LCD driver	Gold Bump Die
ML1001-2U	a 80 segment static LCD driver	Gold Bump Die
ML1001-3U	a 120 segment static LCD driver	Gold Bump Die

❖ **Block Diagram**

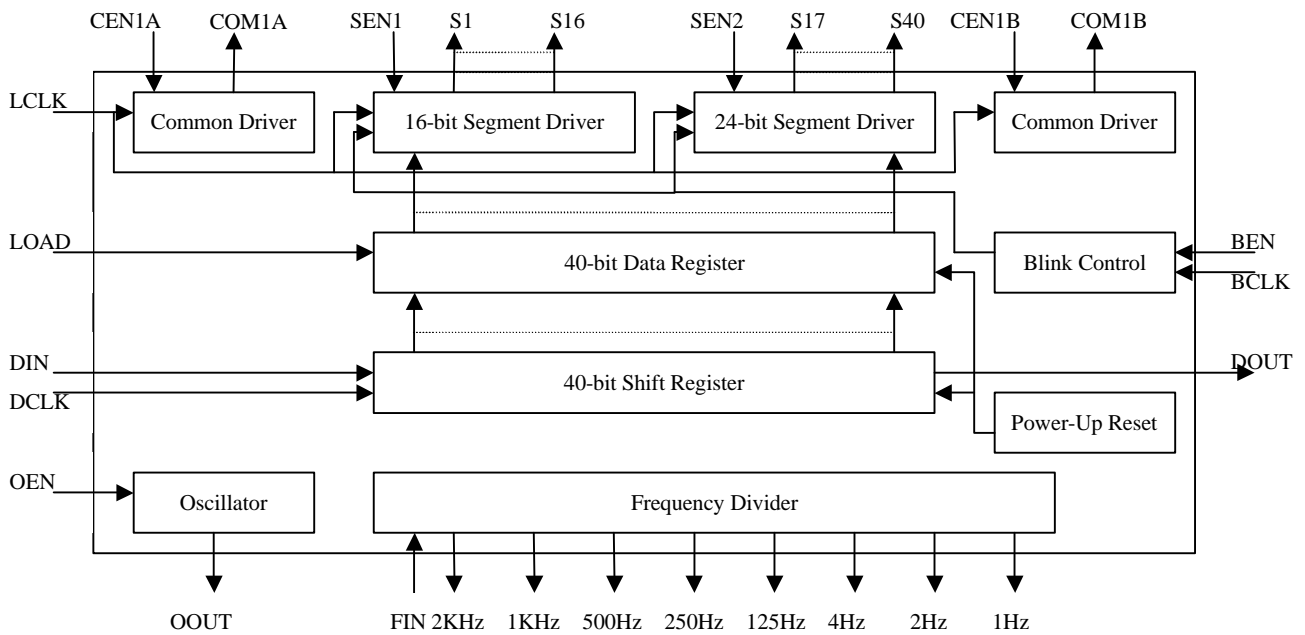

❖ **Absolute Maximum Ratings**

Parameter	Symbol	Condition	MIN	MAX	Unit
Supply voltage	$V_{DD}$		-0.5	+7.0	V
Supply Current	$I_{DD}$	$V_{DD} = 3V$ , no Load	-50	+50	mA
Input Voltage	$V_{IN}$		GND-0.3	$V_{DD} + 0.3$	V
Output Voltage	$V_{OUT}$		GND-0.3	$V_{DD} + 0.3$	V
DC input Current	$I_{IN}$		-10	+10	mA
DC output Current	$I_{OUT}$		-10	+10	mA
Storage temperature	$T_{stg}$		-65	+150	°C
Total power dissipation	$P_{tot}$		-	400	mW

### ❖ DC Characteristic

$V_{DD} = 3.0V$ ;  $T_{amb} = 25^{\circ}C$  ; unless otherwise specified

Parameter	Symbol	Condition	MIN	TYP	MAX	Unit
<b>Supplies</b>						
Supply voltage	$V_{DD}$		2.0	-	6.0	V
Supply Current	$I_{DD}$	Disable Oscillator	-	0.1	0.5	uA
Supply Current	$I_{DD}$	Enable Oscillator	-	25	60	uA
<b>Logic</b>						
LOW-level input voltage	$V_{IL}$		GND	-	$0.3 * V_{DD}$	V
HIGH-level input voltage	$V_{IH}$		$0.7 * V_{DD}$	-	$V_{DD}$	V
LOW-level output current	$I_{OL}$	$V_{OL} = 1.0V$	1	-	-	mA
HIGH-level output current	$I_{OH}$	$V_{OH} = 2.0V$	-1	-	-	mA
<b>LCD outputs</b>						
Output resistance at pads S1 to S40	$R_{SEG}$		-	85	150	ohm
Output resistance at pads COM1A and COM1B	$R_{COM}$		-	45	100	ohm

### ❖ AC Characteristic

$V_{DD} = 3.0V$ ;  $T_{amb} = 25^{\circ}C$ ; unless otherwise specified

Parameter	Symbol	Conditions	MIN	TYP	MAX	Unit
Oscillator frequency at pad OOUT	$f_{out}$		21	32	48	kHz
FIN, LOAD, DIN, DCLK High time	$t_H$		0.4	-	-	us
FIN, LOAD, DIN, DCLK Low time	$t_L$		0.4	-	-	us
FIN, LOAD, DIN, DCLK Rise time	$t_r$		-	-	10	us
FIN, LOAD, DIN, DCLK Fall time	$t_f$		-	-	10	us
DCLK Frequency	$F_{DCLK}$		1	-	1,000	kHz

❖ **Timing Diagram**

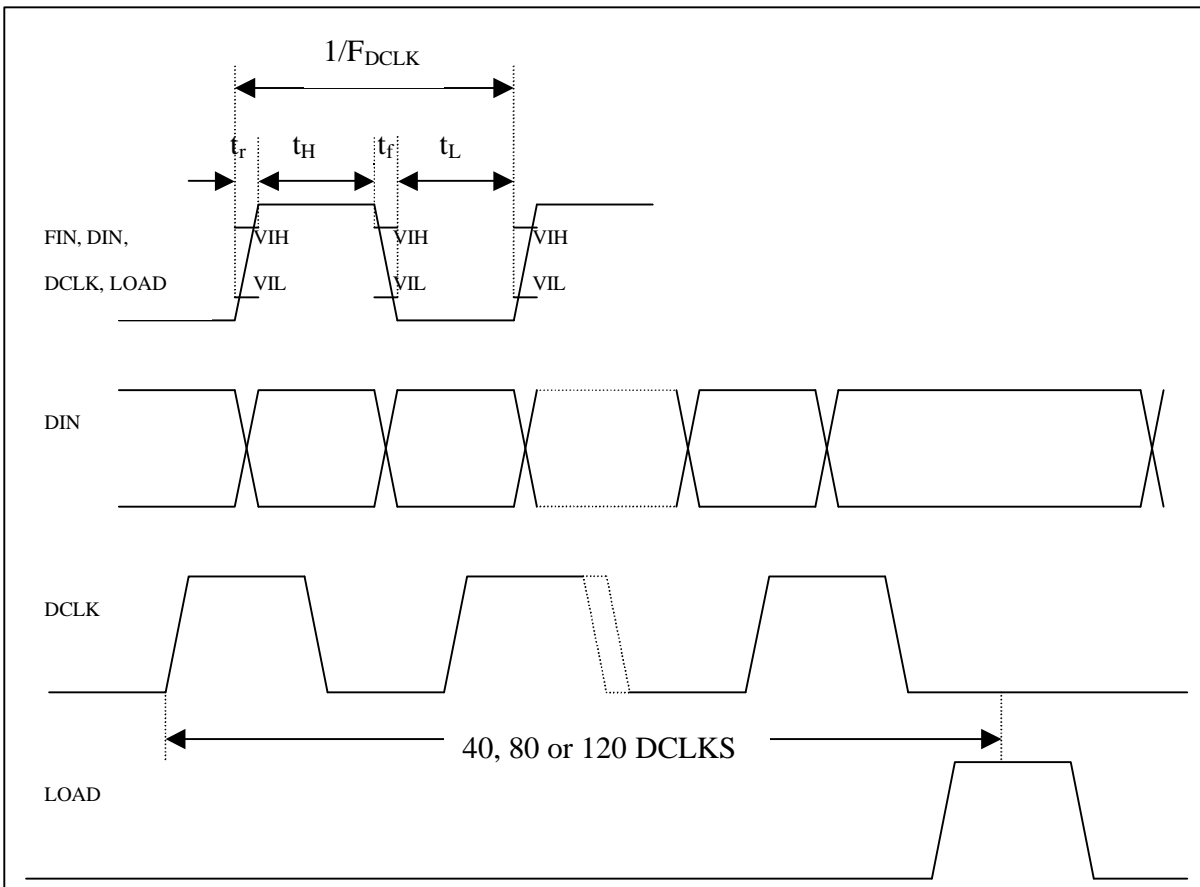

❖ **Functional Description**

The ML1001 is a static LCD COG (chip on glass) driver which can drive upto 40 segments or cascaded with two or three ML1001s to drive 80 & 120 segments. There is a shift register for serially shifting in the data and a data register to store the data that is going to be displayed. The display data is read into the shift register serially through the DIN pin at the rising edge of the DCLK signal. The display data will then be displayed at the rising edge of the LOAD signal. The display data in the shift register is output by the DOUT pin after 40 rising edges of the DCLK signal. The display data should be input in the sequence of SEG40, SEG39... SEG2, SEG1 for proper display of data.

**i) Power on reset**

At Power on the ML1001 resets to a starting condition as follows:

1. The shift register outputs are set to GND.
2. The data register outputs are set to GND, hence all LCD segments off.

**ii) Oscillator**
**a) Internal clock**

The internal logic and the LCD driving signal of ML1001 are clocked either by the built-in oscillator or from an external clock. When the internal oscillator is used, OEN should be connected to GND and the OOUT should be connected to FIN. The oscillator will oscillate at 32 kHz and the frequency is independent in the range of  $2.0V \leq V_{DD} \leq 6.0V$ .

**b) External clock**

When using an external clock, the OEN is connected to VDD then connects the external clock to FIN.

**iii) Timing**

ML1001 have several frequencies of clock signal for the users to choose for the LCD display clock (ie. LCLK) and the blink clock (ie. BCLK). They include the following clock signals :

Frequency of Clock Signal at FIN = 32 kHz	Actual Divider of FIN	Target Input Pin
2 KHz	1/16	LCLK
1 KHz	1/32	
500 Hz	1/64	
256 Hz	1/128	
128 Hz	1/256	
4 Hz	1/8192	BCLK
2 Hz	1/16384	
1 Hz	1/32768	

**iv) Segment outputs**

ML1001 has 40 segment outputs which should be connected directly to the LCD. If less than 40 segments are required, the unused segments should be left open circuit. Users can disable the first 1 to 16 segments and the last 17 to 40 segments by connecting the SEN1 and SEN2 to VDD, respectively. The segment outputs shall output GND level after disabling it.

**v) Common outputs**

ML1001 consists of 2 common signals (ie. COM1A & COM1B). These two common signals are the inversion of the LCLK. The common outputs should be left open-circuit if the outputs are unused. Users can disable the COM1A and COM1B by connecting the CEN1A and CEN1B to VDD, respectively. The common outputs will change to GND after disabling it.

**vi) Blink**

ML1001 has a blink function that users shall connect the BEN to GND and input the blink clock (ie. BCLK) either by connecting ML1001 output clock signal from Frequency Divider or an external clock signal. Users shall disable blink function by connecting BEN to VDD.

❖ *Pad Configuration*

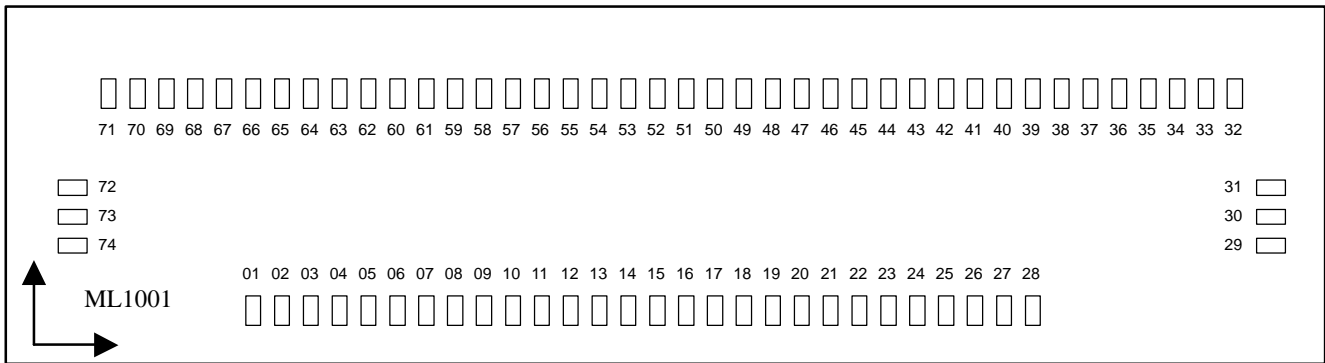

Chip Size :

Part Number	Description	Chip Size
ML1001-1U	a 40 segment static LCD driver	3,440 um x 600 um
ML1001-2U	a 80 segment static LCD driver	6,880 um x 600 um
ML1001-3U	a 120 segment static LCD driver	10,320 um x 600 um

Chip Thickness : 400 um ± 25 um  
 Gold Bump Pad Size : 32 um x 72 um  
 Gold Bump Height : 18 um ± 2 um

Note :

1. The die faces up in the diagram.

**❖ Pad Location**

All x and y coordinates are references to the left lower corner of the chip.

PAD Num.	PAD Name	Coordinate		PAD Num.	PAD Name	Coordinate		PAD Num.	PAD Name	Coordinate	
		X	Y			X	Y			X	Y
1	LOAD	20	40	26	DCLK	2320	40	51	S21	1286	320
2	DIN	120	40	27	DOUT	2400	40	52	S20	1206	320
3	DCLK	220	40	28	LOAD	2500	40	53	S19	1126	320
4	BEN	320	40	29	GND	2826	60	54	S18	1046	320
5	OEN	420	40	30	VDD	2826	140	55	S17	966	320
6	VDD	520	40	31	COM1B	2826	220	56	S16	886	320
7	SEN1	600	40	32	S40	2806	320	57	S15	806	320
8	CEN1A	700	40	33	S39	2726	320	58	S14	726	320
9	SEN2	800	40	34	S38	2646	320	59	S13	646	320
10	CEN1B	900	40	35	S37	2566	320	60	S12	566	320
11	GND	1000	40	36	S36	2486	320	61	S11	486	320
12	OOUT	1080	40	37	S35	2406	320	62	S10	406	320
13	FIN	1180	40	38	S34	2326	320	63	S9	326	320
14	LCLK	1280	40	39	S33	2246	320	64	S8	246	320
15	2 KHz	1360	40	40	S32	2166	320	65	S7	166	320
16	1 KHz	1440	40	41	S31	2086	320	66	S6	86	320
17	500 Hz	1520	40	42	S30	2006	320	67	S5	6	320
18	250 Hz	1600	40	43	S29	1926	320	68	S4	-74	320
19	125 Hz	1680	40	44	S28	1846	320	69	S3	-154	320
20	4 Hz	1760	40	45	S27	1766	320	70	S2	-234	320
21	2 Hz	1840	40	46	S26	1686	320	71	S1	-314	320
22	1 Hz	1920	40	47	S25	1606	320	72	COM1A	-294	220
23	BCLK	2020	40	48	S24	1526	320	73	VDD	-294	140
24	LCLK	2120	40	49	S23	1446	320	74	GND	-294	60
25	BEN	2220	40	50	S22	1366	320				

### ❖ Pin Description

Symbol	Pad	Description
LOAD	1,28	Load data from the shift register to data register; note 1
DIN	2	Display data input pin
DCLK	3,26	Input pin for the clock of the display data; note 1
BEN	4,25	Enable pin of the blink function; note 1, note 2
OEN	5	Enable pin of the internal oscillator; note 2
V <sub>DD</sub>	6	Supply voltage
SEN1	7	Enable pin of the segment from S1 to S16; note 1
CEN1A	8	Enable pin of the COM1A; note 2
SEN2	9	Enable pin of the segment from S17 to S40; note 1
CEN1B	10	Enable pin of the COM1B; note 2
GND	11	Logic ground
OOUT	12	Output pin of the internal oscillator
FIN	13	Input pin of the external/internal clock
LCLK	14,24	Input pin to the LCD display clock; note 1
2 kHz	15	Output 1/16 frequency of the input to the FIN; note 3
1 kHz	16	Output 1/32 frequency of the input to the FIN; note 3
512 Hz	17	Output 1/64 frequency of the input to the FIN; note 3
256 Hz	18	Output 1/128 frequency of the input to the FIN; note 3
128 Hz	19	Output 1/256 frequency of the input to the FIN; note 3
4 Hz	20	Output 1/8192 frequency of the input to the FIN; note 3
2 Hz	21	Output 1/16384 frequency of the input to the FIN; note 3
1 Hz	22	Output 1/32768 frequency of the input to the FIN; note 3
BCLK	23	Input pin for the blink clock
DOUT	27	Output pin for 40-bit Shift register, it shall connect to DIN of next ML1001
GND	29	Logic ground
V <sub>DD</sub>	30	Supply voltage
COM1B	31	Common driving signal to LCD panel
S40 to S1	32 to 71	LCD segment outputs
COM1A	72	Common driving signal to LCD panel
V <sub>DD</sub>	73	Supply voltage
GND	74	Logic ground

Note :

1. In cascade format of ML1001 (ie. ML1001-2U and -3U), one pin is the input of current ML1001 and the other is for the connection with the corresponding input pin of next ML1001.
2. All Enable pins are active low.
3. Condition : FIN = 32 KHz Clock.



❖ **Application Examples**

**ML1001-1U Standard Application**

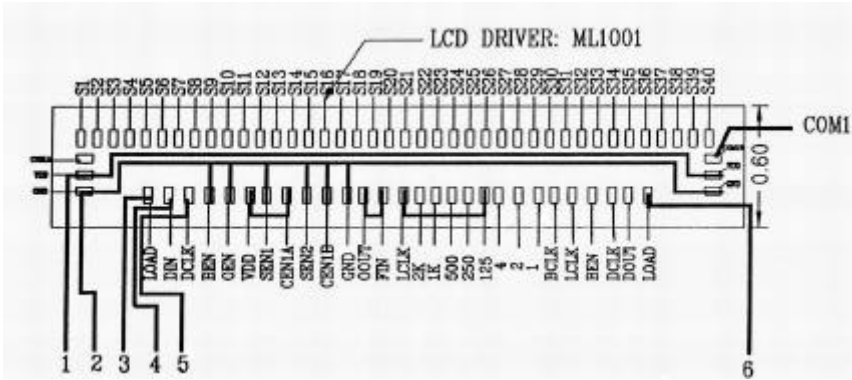

Pin	Pin Name
1	VDD
2	GND
3	LOAD
4	DIN
5	DCLK
6	CHECK

**ML1001-1U Application Circuit with 1 Hz Blink Feature**

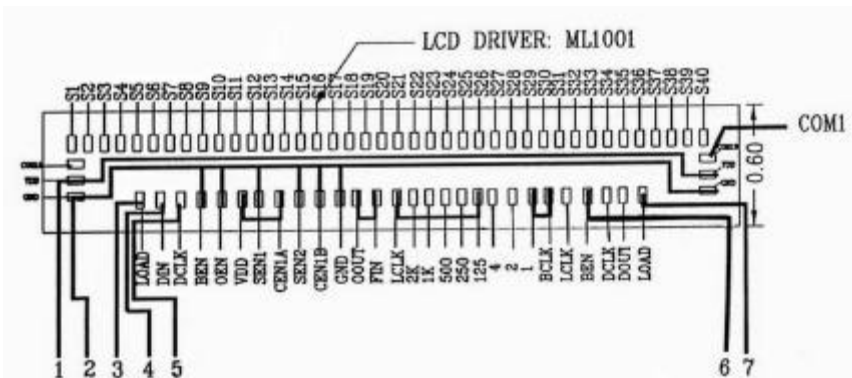

Pin	Pin Name
1	VDD
2	GND
3	LOAD
4	DIN
5	DCLK
6	BEN
7	CHECK

*Note : Blink at 1 Hz if BEN = 0V, Normal Display if BEN = VDD.*

**ML1001-1U Application Circuit with External 32 KHz Clock**

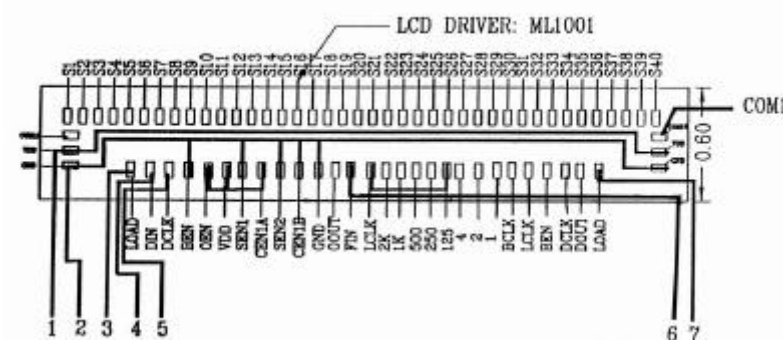

Pin	Pin Name
1	VDD
2	GND
3	LOAD
4	DIN
5	DCLK
6	FIN
7	CHECK

*Note : If External 32 KHz Clock Signal is available, designer can turn off Internal Oscillator to save power.*

**Note : Pin LOAD and Pin CHECK shall be connected together if the flip-chip assembly is in good condition. Hence, Pin CHECK can be served for qualifying the flip-chip assembly quality.**

**ML1001-2U Standard Application**

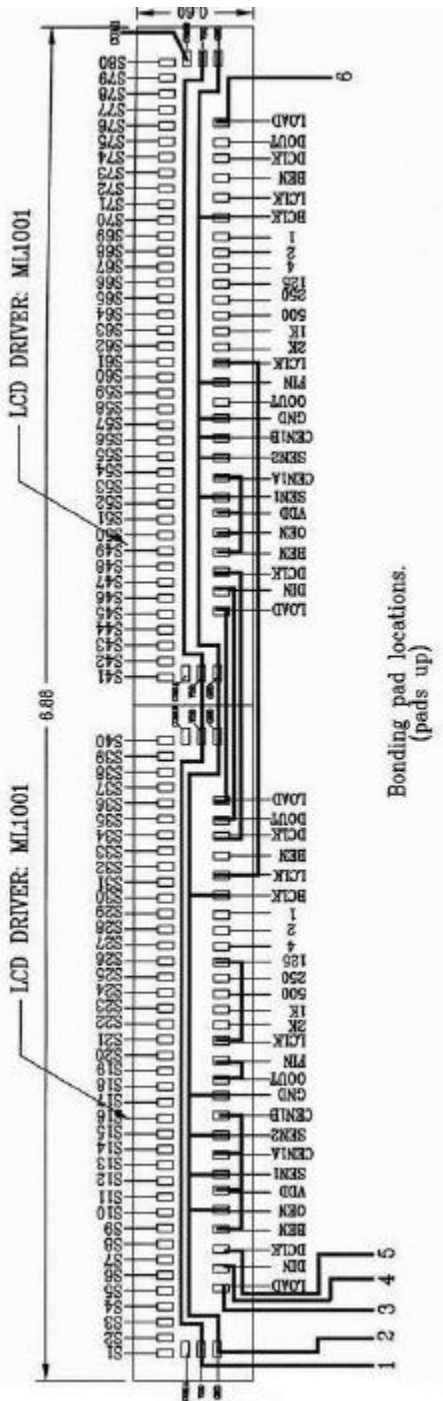

Pin	Pin Name
1	VDD
2	GND
3	LOAD
4	DIN
5	DCLK
6	CHECK

**Note :**

**Chip 1 Pad Coordinate shall follow "Table of Pad Location".  
Chip 2 Pad Coordinate shall be calculated as follow :**

Chip 2 X-Coordinate = Chip 1 X-Coordinate + 3,440um

Chip 2 Y-Coordinate = Chip 1 Y-Coordinate

**ML1001-3U Standard Application**

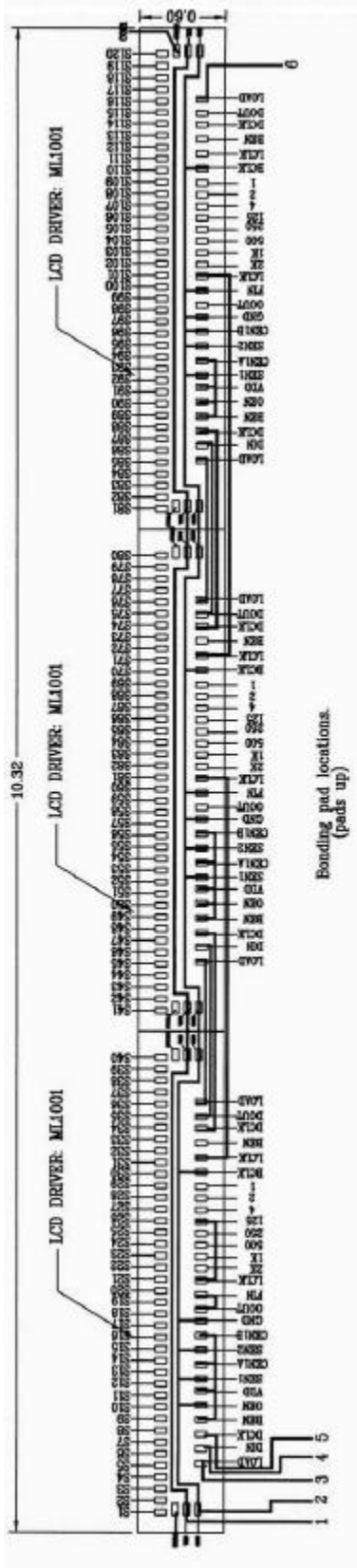

Pin	Pin Name
1	VDD
2	GND
3	LOAD
4	DIN
5	DCLK
6	CHECK

**Note :**

**Chip 1 Pad Coordinate shall follow “Table of Pad Location”.  
Chip 2 Pad Coordinate shall be calculated as follow :**

Chip 2 X-Coordinate = Chip 1 X-Coordinate + 3,440um  
Chip 2 Y-Coordinate = Chip 1 Y-Coordinate

**Chip 3 Pad Coordinate shall be calculated as follow :**

Chip 3 X-Coordinate = Chip 1 X-Coordinate + 6,880um  
Chip 3 Y-Coordinate = Chip 1 Y-Coordinate

❖ **Typical Characteristics**

**1) Supply Current vs. Frequency of LCLK**

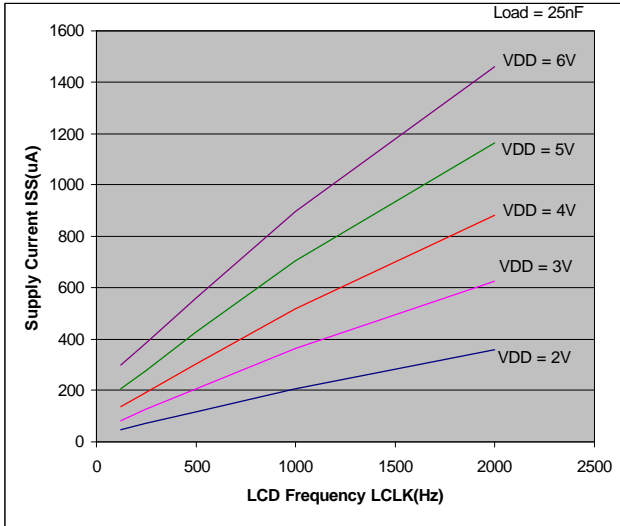

**2) Supply Current vs. Input Voltage**

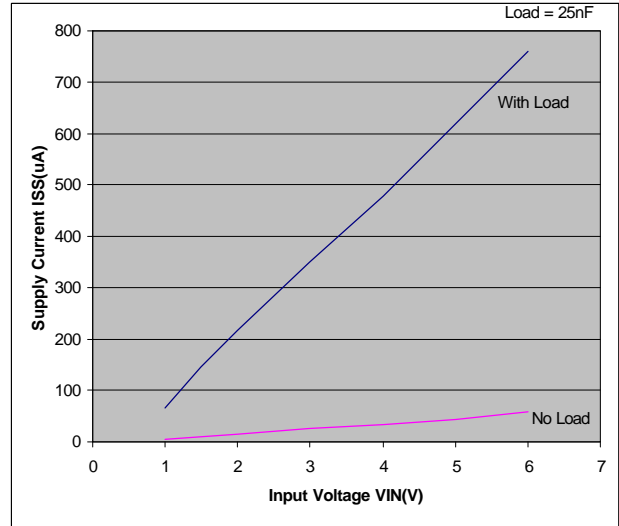

**3) Example of Contrast Ratio vs. Input Voltage**

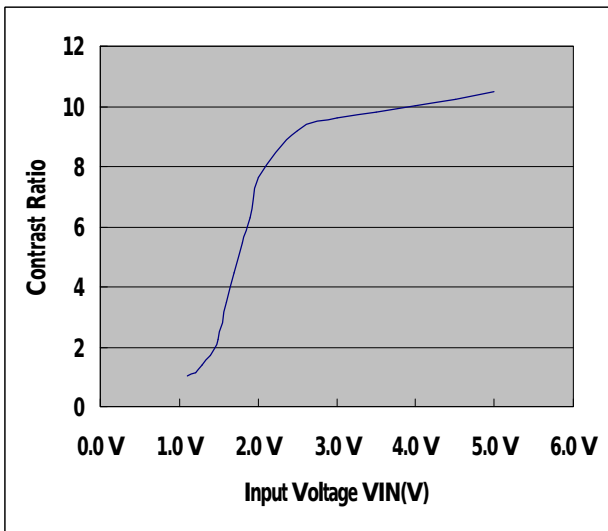

**4) Example of Contrast Ratio vs. Viewing Angle**

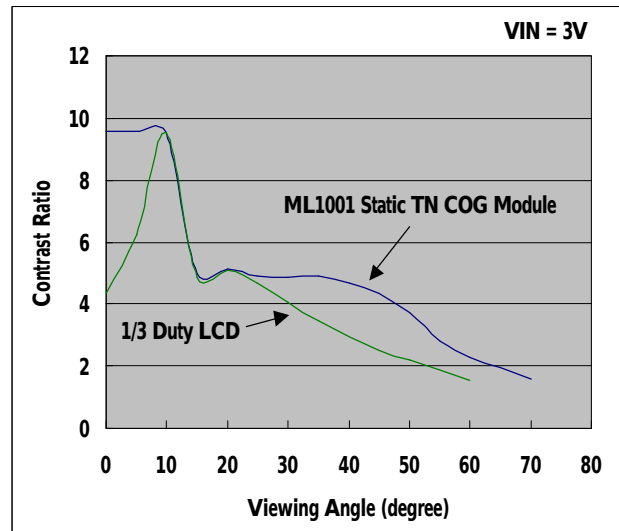

- Note: 1. Contrast ratio of LCD shall vary from the Liquid Crystal used.  
 2. Contrast ratio of 1/3 Duty LCD is shown on graph 4 for comparison only.  
 3. The viewing angle is measured from the normal of LCD as shown below.

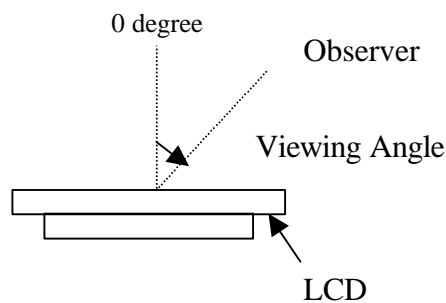

❖ *History of Revision*

<b>REV</b>	<b>DESCRIPTION</b>	<b>DATE</b>
	First Official Specification	8/11/02

The information presented in this document does not form part of any quotation or contract, is believed to be accurate and reliable and may be changed without notice. No liability will be accepted by the publisher for any consequence of its use.