

8Mb Ultra-Low Power Asynchronous Medical CMOS SRAM

512K × 16 bit

Overview

The N08M1618L1A is an integrated memory device **intended for non life-support medical applications**. This device is a 8 megabit memory organized as 524,288 words by 16 bits. The device is designed and fabricated using AMI Semiconductor's advanced CMOS technology with reliability enhancements for medical users. The device operates with two chip enable ($\overline{CE1}$ and $\overline{CE2}$) controls and output enable (\overline{OE}) to allow for easy memory expansion. Byte controls (\overline{UB} and \overline{LB}) allow the upper and lower bytes to be accessed independently and can also be used to deselect the device. This device is optimal for various applications where low-power is critical such as battery backup and hand-held devices. The device can operate over a very wide temperature range of -40°C to +85°C and is available in a JEDEC standard BGA package.

Features

- **Dual voltage for Optimum Performance:**
 V_{CCQ} - 2.3 to 3.6 Volts
 V_{CC} - 1.4 to 2.2 Volts
- **Very low standby current**
 0.5µA at 1.8V and 37 deg C
- **Very low operating current**
 1.0mA at 1.8V and 1µs (Typical)
- **Very low Page Mode operating current**
 0.5mA at 1.8V and 1µs (Typical)
- **Simple memory control**
 Dual Chip Enables ($\overline{CE1}$ and $\overline{CE2}$)
 Byte control for independent byte operation
 Output Enable (\overline{OE}) for memory expansion
- **Low voltage data retention**
 $V_{CC} = 1.2V$
- **Special Processing to reduce Soft Error Rate (SER)**
- **Automatic power down to standby mode**

Product Family

Part Number	Package Type	Operating Temperature	Power Supply	Speed	Standby Current (I_{SB}), Max	Operating Current (I_{CC}), Max
N08M1618L1AB	48 - BGA	-40°C to +85°C	2.3V-3.6V(V_{CCQ}) 1.4V-2.2V(V_{CC})	85ns @ 1.7V 150ns @ 1.4V	20 µA	2.5 mA @ 1MHz
N08M1618L1AW	Wafer					

Pin Configuration

	1	2	3	4	5	6
A	\overline{LB}	\overline{OE}	A ₀	A ₁	A ₂	CE2
B	I/O ₈	\overline{UB}	A ₃	A ₄	$\overline{CE1}$	I/O ₀
C	I/O ₉	I/O ₁₀	A ₅	A ₆	I/O ₁	I/O ₂
D	V _{SS}	I/O ₁₁	A ₁₇	A ₇	I/O ₃	V _{CC}
E	V _{CCQ}	I/O ₁₂	NC	A ₁₆	I/O ₄	V _{SS}
F	I/O ₁₄	I/O ₁₃	A ₁₄	A ₁₅	I/O ₅	I/O ₆
G	I/O ₁₅	NC	A ₁₂	A ₁₃	\overline{WE}	I/O ₇
H	A ₁₈	A ₈	A ₉	A ₁₀	A ₁₁	NC

48 Pin BGA (top)
8 x 10 mm

Pin Descriptions

Pin Name	Pin Function
A ₀ -A ₁₈	Address Inputs
\overline{WE}	Write Enable Input
$\overline{CE1}$, $\overline{CE2}$	Chip Enable Input
\overline{OE}	Output Enable Input
\overline{LB}	Lower Byte Enable Input
\overline{UB}	Upper Byte Enable Input
I/O ₀ -I/O ₁₅	Data Inputs/Outputs
V _{CC}	Power
V _{SS}	Ground
V _{CCQ}	Power I/O pins only
NC	Not Connected

Functional Block Diagram

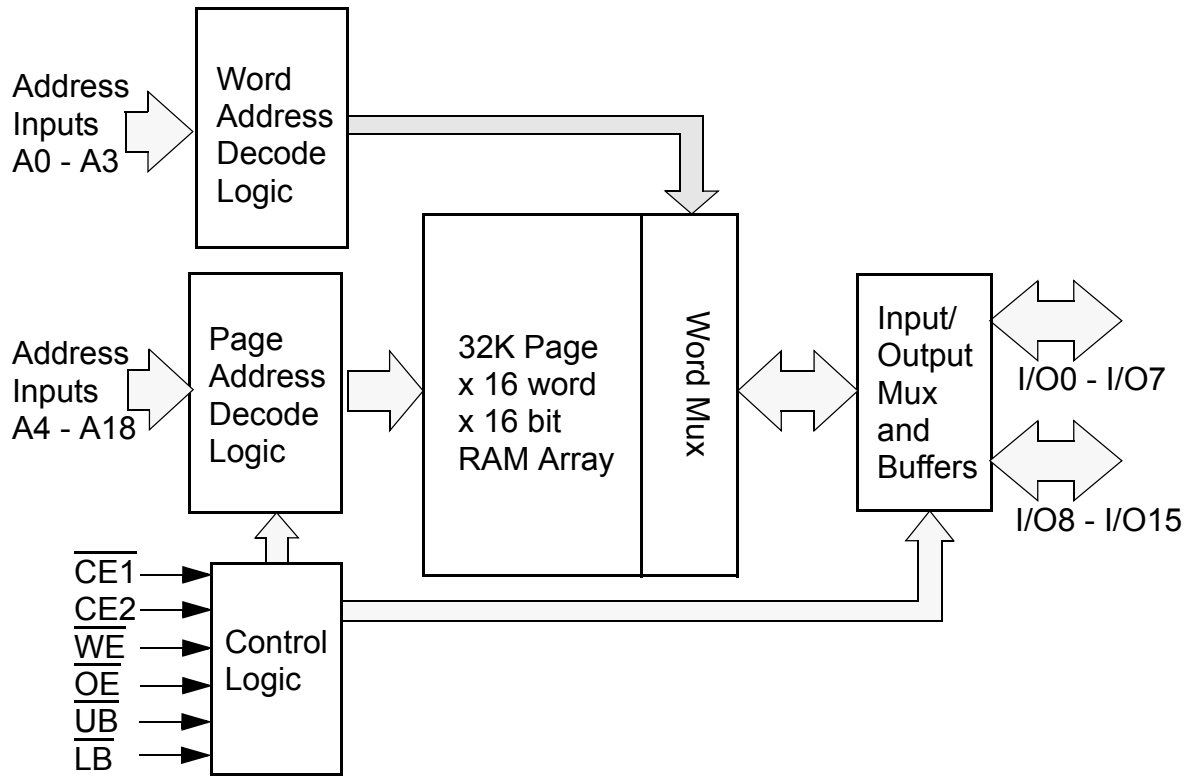

Functional Description

$\overline{CE1}$	$\overline{CE2}$	\overline{WE}	\overline{OE}	\overline{UB}	\overline{LB}	$I/O_0 - I/O_{15}^1$	MODE	POWER
H	X	X	X	X	X	High Z	Standby ²	Standby
X	L	X	X	X	X	High Z	Standby ²	Standby
X	X	X	X	H	H	High Z	Standby ²	Standby
L	H	L	X ³	L ¹	L ¹	Data In	Write ³	Active -> Standby ⁴
L	H	H	L	L ¹	L ¹	Data Out	Read	Active -> Standby ⁴
L	H	H	H	L ¹	L ¹	High Z	Active	Standby ⁴

1. When \overline{UB} and \overline{LB} are in select mode (low), $I/O_0 - I/O_{15}$ are affected as shown. When \overline{LB} only is in the select mode only $I/O_0 - I/O_7$ are affected as shown. When \overline{UB} is in the select mode only $I/O_8 - I/O_{15}$ are affected as shown.

2. When the device is in standby mode, control inputs (\overline{WE} , \overline{OE} , \overline{UB} , and \overline{LB}), address inputs and data input/outputs are internally isolated from any external influence and disabled from exerting any influence externally.

3. When \overline{WE} is invoked, the \overline{OE} input is internally disabled and has no effect on the circuit.

4. The device will consume active power in this mode whenever addresses are changed. Data inputs are internally isolated from any external influence.

Capacitance¹

Item	Symbol	Test Condition	Min	Max	Unit
Input Capacitance	C_{IN}	$V_{IN} = 0V, f = 1\text{ MHz}, T_A = 25^\circ\text{C}$		8	pF
I/O Capacitance	$C_{I/O}$	$V_{IN} = 0V, f = 1\text{ MHz}, T_A = 25^\circ\text{C}$		8	pF

1. These parameters are verified in device characterization and are not 100% tested

Absolute Maximum Ratings¹

Item	Symbol	Rating	Unit
Voltage on any pin relative to V _{SS}	V _{IN,OUT}	-0.3 to V _{CC} +0.3	V
Voltage on V _{CC} Supply Relative to V _{SS}	V _{CC}	-0.3 to 4.5	V
Power Dissipation	P _D	500	mW
Storage Temperature	T _{STG}	-40 to 125	°C
Operating Temperature	T _A	-40 to +85	°C
Soldering Temperature and Time	T _{SOLDER}	240°C, 10sec(Lead only)	°C

1. Stresses greater than those listed above may cause permanent damage to the device. This is a stress rating only and functional operation of the device at these or any other conditions above those indicated in the operating section of this specification is not implied. Exposure to absolute maximum rating conditions for extended periods may affect reliability.

Operating Characteristics (Over Specified Temperature Range)

Item	Symbol	Test Conditions	Min.	Typ ¹	Max	Unit
Core Supply Voltage	V _{CC}		1.4	1.8	2.2	V
I/O Supply Voltage	V _{CCQ}	V _{CCQ} > or = V _{CC}	2.3		3.6	V
Data Retention Voltage	V _{DR}	Chip Disabled ³	1.2			V
Input High Voltage	V _{IH}		V _{CCQ} -0.6		V _{CCQ} +0.3	V
Input Low Voltage	V _{IL}		-0.3		0.6	V
Output High Voltage	V _{OH}	I _{OH} = 0.2mA	V _{CCQ} -0.2			V
Output Low Voltage	V _{OL}	I _{OL} = -0.2mA			0.2	V
Input Leakage Current	I _{LI}	V _{IN} = 0 to V _{CC}			0.1	μA
Output Leakage Current	I _{LO}	\overline{OE} = V _{IH} or Chip Disabled			0.1	μA
Read/Write Operating Supply Current @ 1 μs Cycle Time ²	I _{CC1}	V _{CC} =2.2 V, V _{IN} =V _{IH} or V _{IL} Chip Enabled, I _{OUT} = 0		1.5	2.5	mA
Read/Write Operating Supply Current @ 85 ns Cycle Time ²	I _{CC2}	V _{CC} =2.2 V, V _{IN} =V _{IH} or V _{IL} Chip Enabled, I _{OUT} = 0		10.0	13.0	mA
Page Mode Operating Supply Current @ 85 ns Cycle Time ² (Refer to Power Savings with Page Mode Operation diagram)	I _{CC3}	V _{CC} =2.2 V, V _{IN} =V _{IH} or V _{IL} Chip Enabled, I _{OUT} = 0		3.5		mA
Read/Write Quiescent Operating Supply Current ³	I _{CC4}	V _{CC} =2.2 V, V _{IN} =V _{IH} or V _{IL} Chip Enabled, I _{OUT} = 0, f = 0		1		μA
Standby Current ³	I _{SB1}	V _{IN} = V _{CC} or 0V Chip Disabled t _A = 85°C, V _{CC} = 2.2 V		0.5	20.0	μA
Data Retention Current ³	I _{DR}	V _{CC} = 1.2V, V _{IN} = V _{CC} or 0 Chip Disabled, t _A = 85°C		0.1	1.0	μA

1. Typical values are measured at V_{CC}=V_{CC} Typ., T_A=25°C and not 100% tested.

2. This parameter is specified with the outputs disabled to avoid external loading effects. The user must add current required to drive output capacitance expected in the actual system.

3. This device assumes a standby mode if the chip is disabled ($\overline{CE1}$ high or CE2 low). In order to achieve low standby current all inputs must be within 0.2 volts of either V_{CC} or V_{SS}.

Power Savings with Page Mode Operation ($\overline{WE} = V_{IH}$)

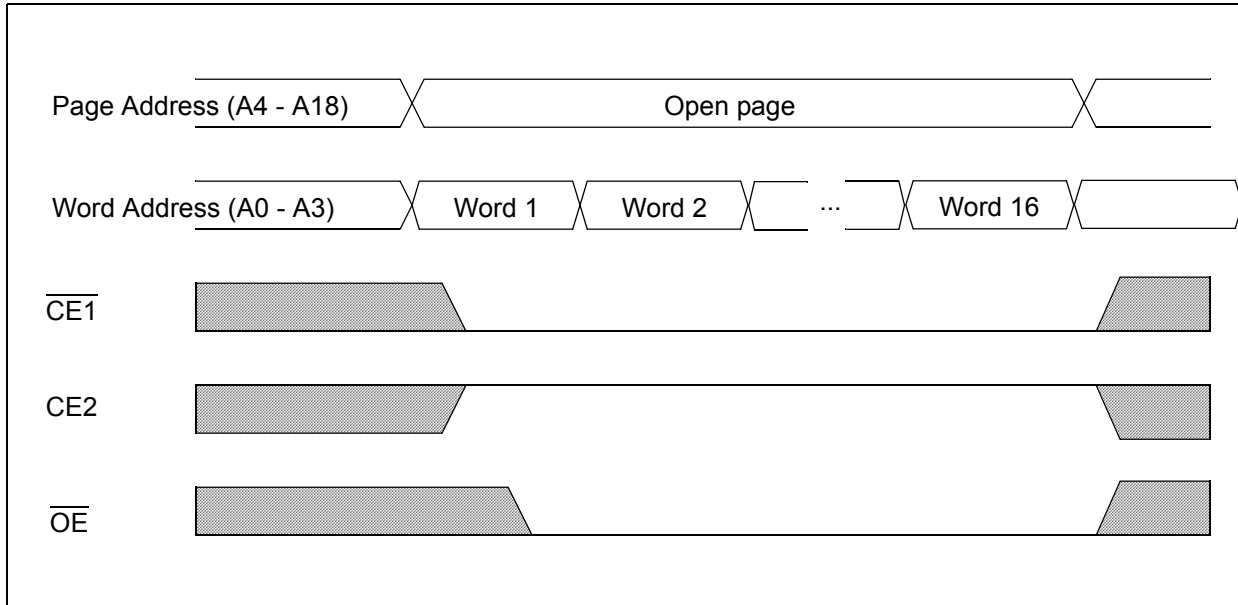

Note: Page mode operation is a method of addressing the SRAM to save operating current. The internal organization of the SRAM is optimized to allow this unique operating mode to be used as a valuable power saving feature.

The only thing that needs to be done is to address the SRAM in a manner that the internal page is left open and 8-bit words of data are read from the open page. By treating addresses A0-A3 as the least significant bits and addressing the 16 words within the open page, power is reduced to the page mode value which is considerably lower than standard operating currents for low power SRAMs.

Timing Test Conditions

Item	
Input Pulse Level	0.1V _{CC} to 0.9 V _{CC}
Input Rise and Fall Time	5ns
Input and Output Timing Reference Levels	0.5 V _{CC}
Output Load	CL = 30pF
Operating Temperature	-40 to +85 °C

Timing V_{CCQ} > or = V_{CC}

Item	Symbol	V _{CC} = 1.4 - 2.2 V		V _{CC} = 1.7 - 2.2 V		Units
		Min.	Max.	Min.	Max.	
Read Cycle Time	t _{RC}	150		85		ns
Address Access Time	t _{AA}		150		85	ns
Address Access Time (Page Mode)	t _{AAP}		30		30	ns
Chip Enable to Valid Output	t _{CO}		150		85	ns
Output Enable to Valid Output	t _{OE}		50		40	ns
Byte Select to Valid Output	t _{LB} , t _{UB}		150		85	ns
Chip Enable to Low-Z output	t _{LZ}	20		10		ns
Output Enable to Low-Z Output	t _{OLZ}	20		5		ns
Byte Select to Low-Z Output	t _{LBZ} , t _{UBZ}	20		10		ns
Chip Disable to High-Z Output	t _{HZ}	0	30	0	15	ns
Output Disable to High-Z Output	t _{OHZ}	0	30	0	15	ns
Byte Select Disable to High-Z Output	t _{LBHZ} , t _{UBHZ}	0	30	0	15	ns
Output Hold from Address Change	t _{OH}	20		10		ns
Write Cycle Time	t _{WC}	150		85		ns
Chip Enable to End of Write	t _{CW}	75		50		ns
Address Valid to End of Write	t _{AW}	75		50		ns
Byte Select to End of Write	t _{LBW} , t _{UBW}	75		50		ns
Write Pulse Width	t _{WP}	50		40		ns
Address Setup Time	t _{AS}	0		0		ns
Write Recovery Time	t _{WR}	0		0		ns
Write to High-Z Output	t _{WHZ}		30		15	ns
Data to Write Time Overlap	t _{DW}	50		40		ns
Data Hold from Write Time	t _{DH}	0		0		ns
End Write to Low-Z Output	t _{OW}	10		5		ns

Timing of Read Cycle ($\overline{CE1} = \overline{OE} = V_{IL}, \overline{WE} = CE2 = V_{IH}$)

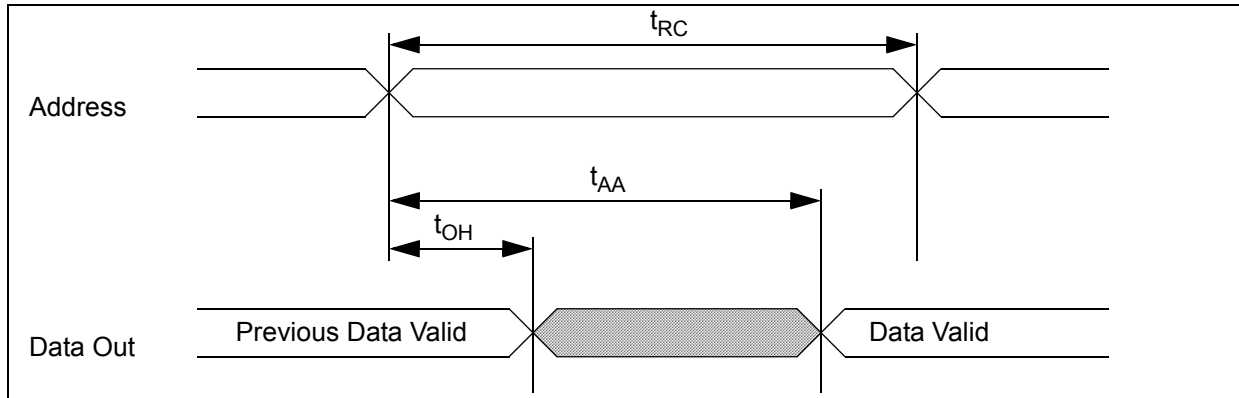

Timing Waveform of Read Cycle ($\overline{WE} = V_{IH}$)

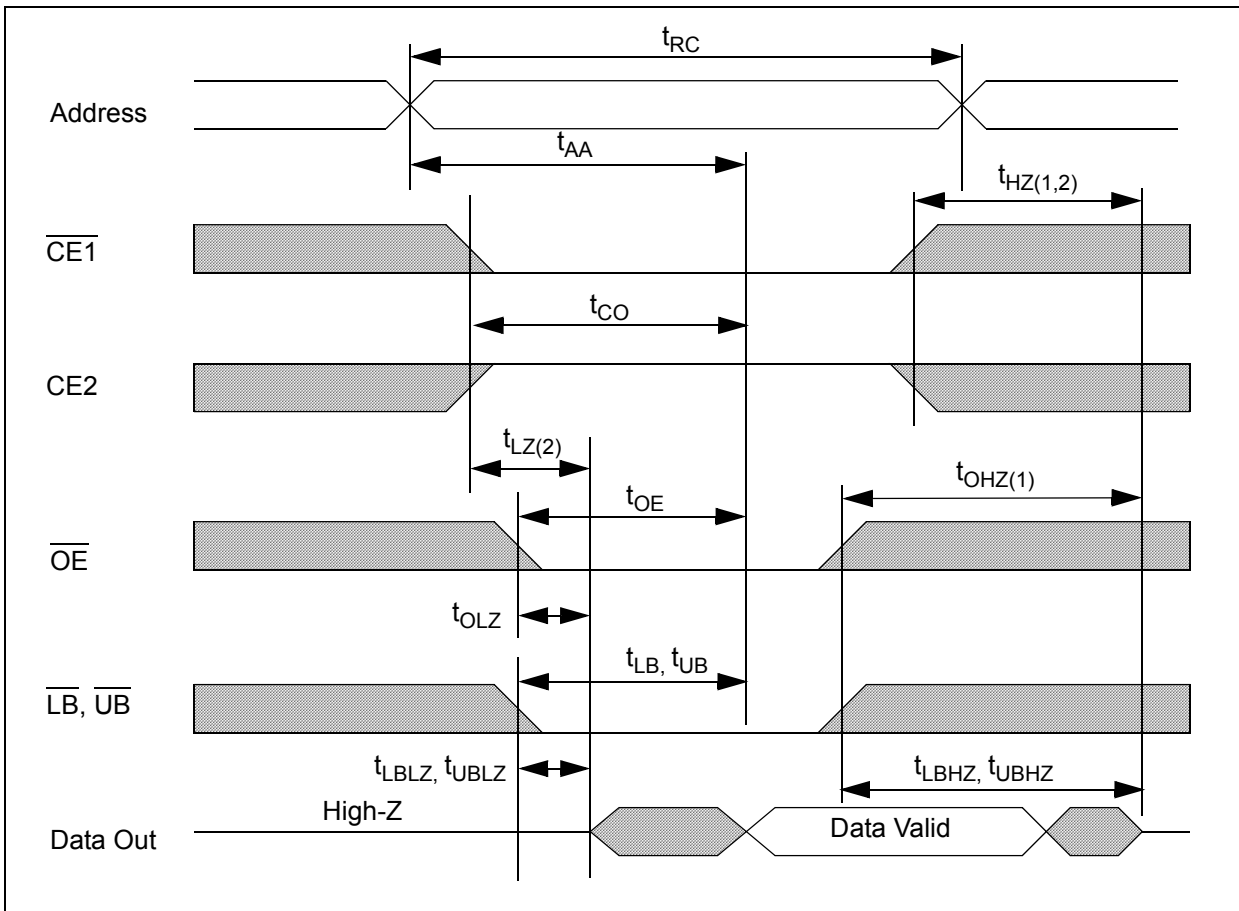

Timing Waveform of Page Mode Read Cycle ($\overline{WE} = V_{IH}$)

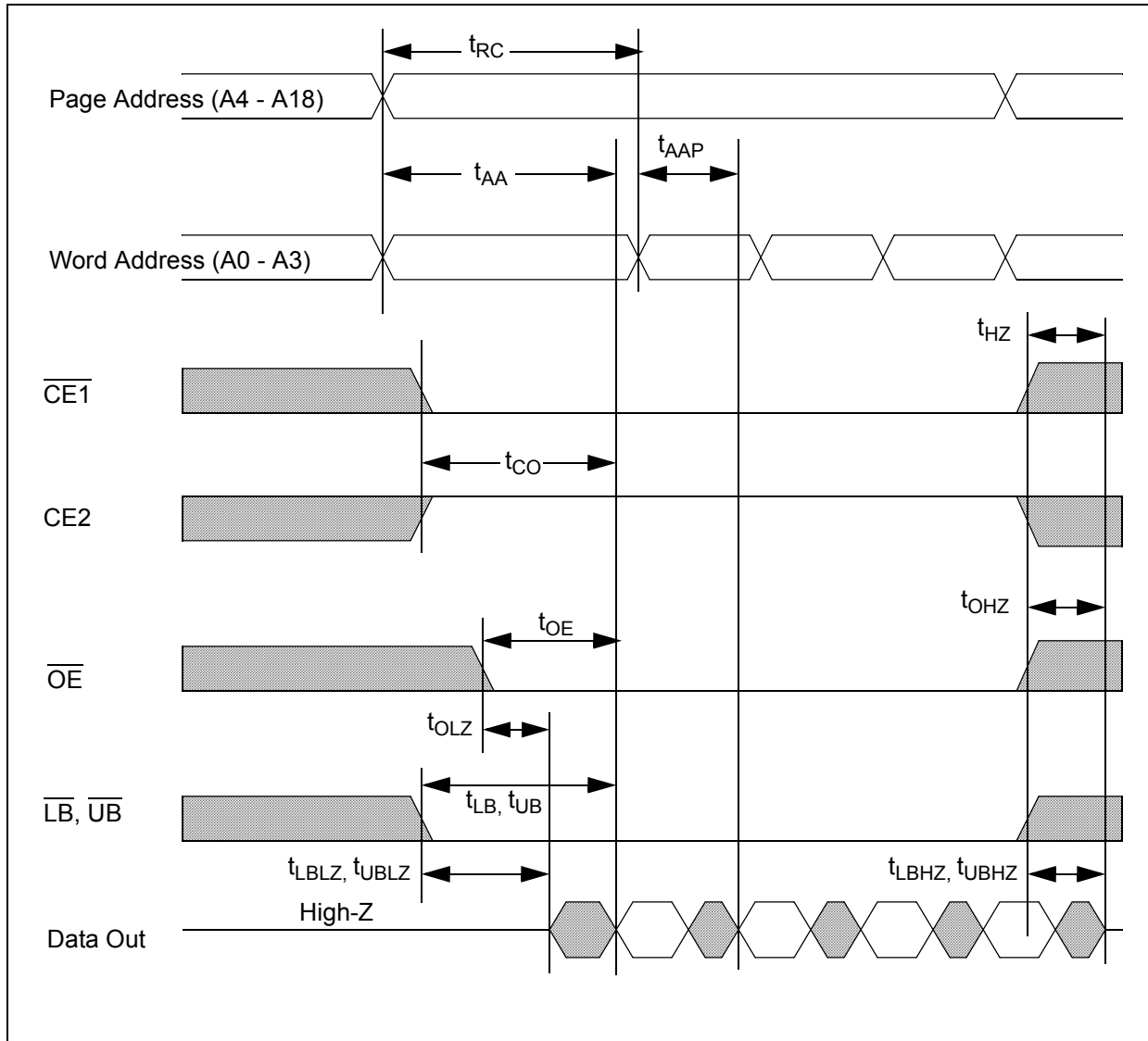

Timing Waveform of Write Cycle (\overline{WE} control)

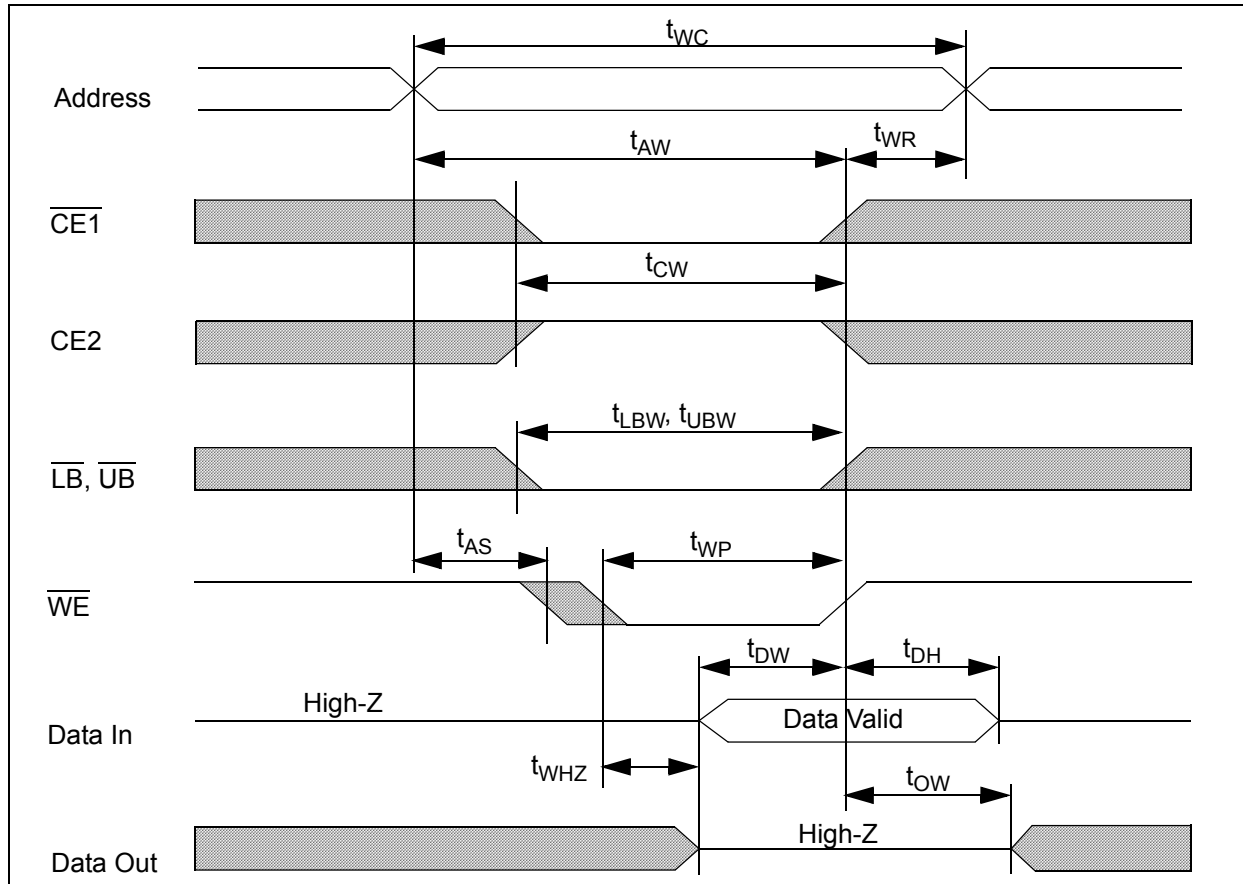

Timing Waveform of Write Cycle ($\overline{\text{CE1}}$ Control)

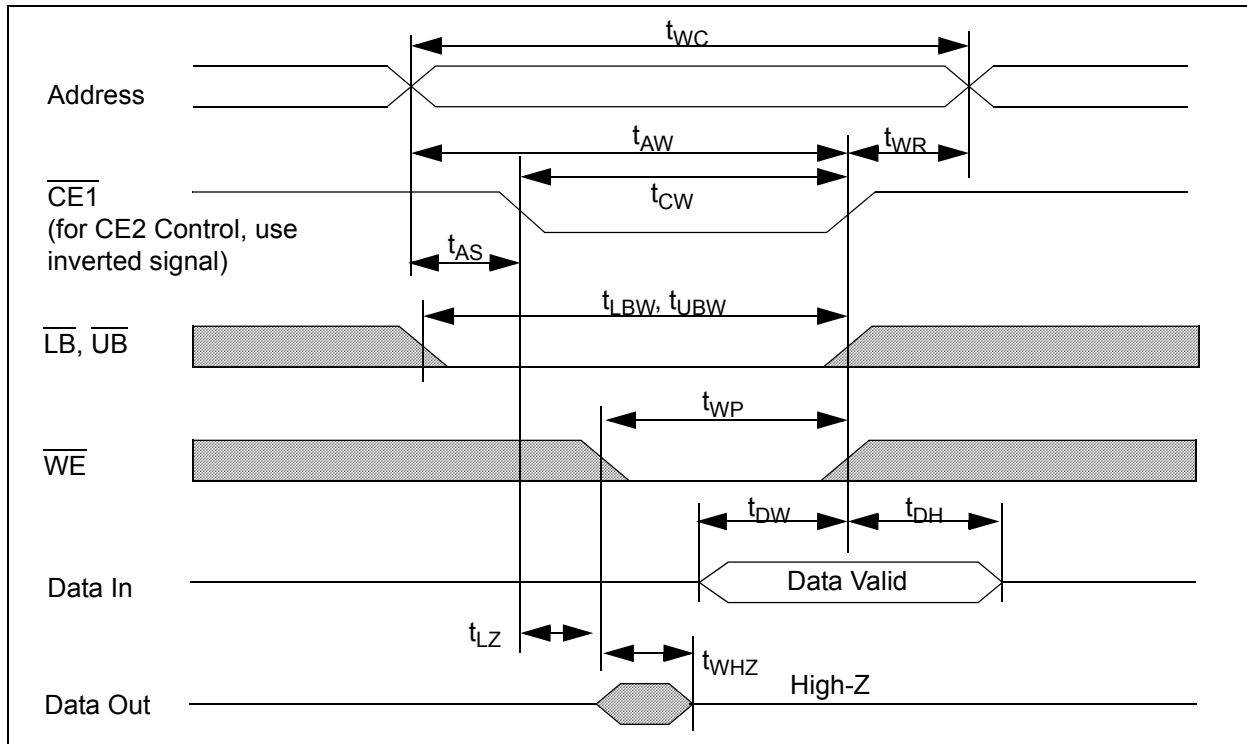

Ball Grid Array Package

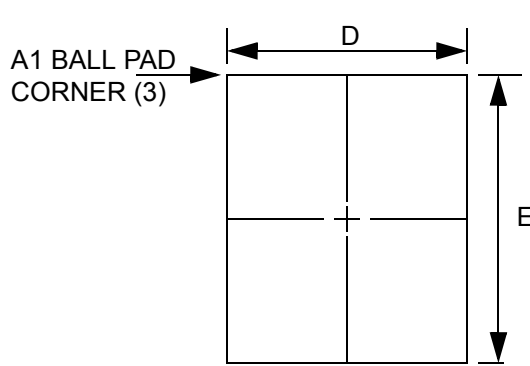

TOP VIEW

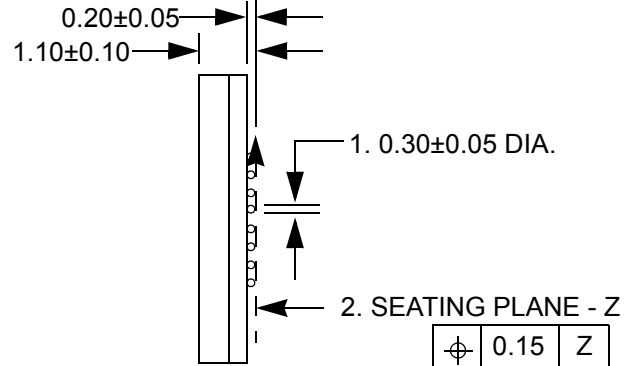

SIDE VIEW

∅	0.15	Z
∅	0.05	Z

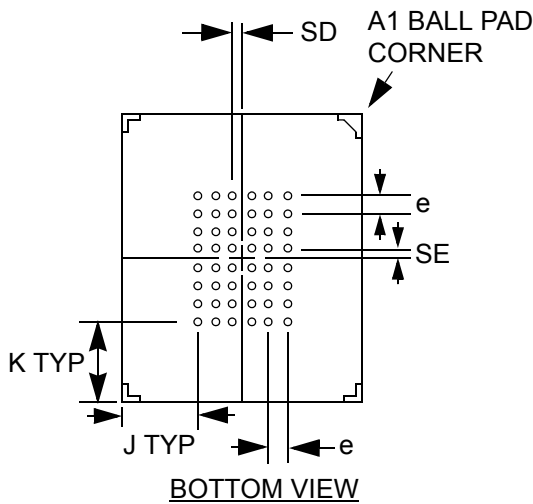

BOTTOM VIEW

1. DIMENSION IS MEASURED AT THE MAXIMUM SOLDER BALL DIAMETER. PARALLEL TO PRIMARY Z.
2. PRIMARY DATUM Z AND SEATING PLANE ARE DEFINED BY THE SPHERICAL CROWNS OF THE SOLDER BALLS.
3. A1 BALL PAD CORNER I.D. TO BE MARKED BY INK.

Dimensions (mm)

D	E	e = 0.75				BALL MATRIX TYPE
		SD	SE	J	K	
8±0.10	10±0.10	0.375	0.375	2.125	2.375	FULL

Ordering Information

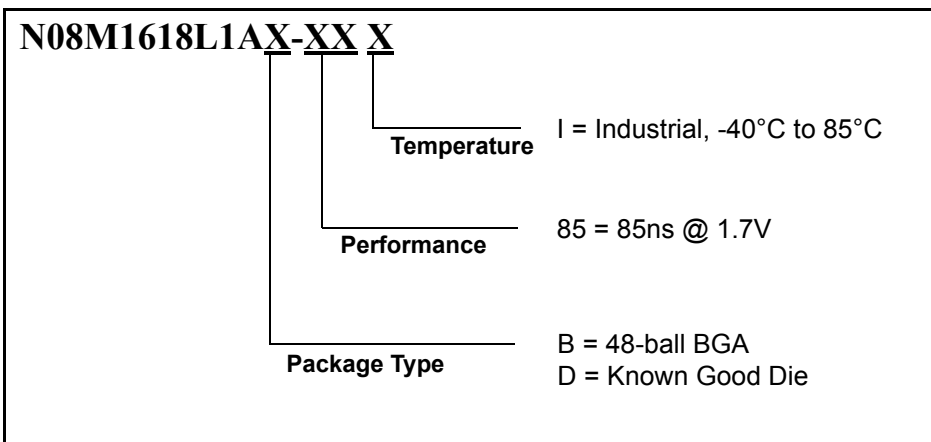

Revision History

Revision #	Date	Change Description
01	11/01/02	Initial Release
02	3/03/05	General Update: Updated ICC4 typical and ISB1 typical value Updated Block Diagram, Functional Description Table. Added tAAP, tLB, tUB, tLBZ, tUBZ, tLBHZ, tUBHZ, tLBW, tUBW timing parameters. Added Page Mode Read Timing Waveform Updated BGA 8X10 Package Drawing Updated VccQ range on DC Parameters Table
03	9/21/2006	Converted to AMI Semiconductor

© 2006 AMI Semiconductor, Inc. All rights reserved.

AMI Semiconductor, Inc. ("AMIS") reserves the right to change or modify the information contained in this data sheet and the products described therein, without prior notice. AMIS does not convey any license under its patent rights nor the rights of others. Charts, drawings and schedules contained in this data sheet are provided for illustration purposes only and they vary depending upon specific applications.

AMIS makes no warranty or guarantee regarding suitability of these products for any particular purpose, nor does AMIS assume any liability arising out of the application or use of any product or circuit described herein. AMIS does not authorize use of its products as critical components in any application in which the failure of the AMIS product may be expected to result in significant injury or death, including life support systems and critical medical instruments.