



A. HE80128M Introduction

HE80128M is a member of Jess Tech HE8000 series 8-bit CMOS micro-controller. This chip is a Power Speech Controller. It built-in one internal Op-Amp, one 7-bit D/A converter and one PWM output module to provide a speech output interface. Use the built-in 384K ROM can store around 128 seconds of speech data (8KHz sampling rate ADPCM). Use external SRAM or Flash RAM for recording function.

The HE80128M provides a very simple and effective instruction set, each instruction byte occupies only 1.5 clock cycle time, therefore, it is suitable to apply in the high performance systems.

B. HE80128M Features

- Operating Voltage: 2.4V ~ 5.2V
- Operation frequency Range: DC ~ 8MHz @ 5.0V
DC ~ 4MHz @ 2.4V
- ROM size: 384K Bytes
- RAM size: 128 Bytes
- Dual Clock: Normal(Fast) clock: 32.768K ~ 8MHz
Slow clock: 32.768KHz
- Operating Mode: DUAL , FAST , SLOW , IDLE , SLEEP
- Built-in WATCH DOG TIMER
- 24 bi-directional I/O pins, PUSH-PULL or OPEN DRAIN output selected by mask option
- Built-in an internal Op-Amp
- Built-in one D/A Converter
- Built-in a PWM output circuit
- Provides two internal and two external interrupt
- Provides two 16-bit timer (no time base)
- Instruction Set : 32 Instructions, 4 types of Addressing Mode, 2 individual Pointer for ROM (24-bit) and RAM (8-bit) table access.
- Multi-channel voice function.

C. HE80128M Application

- Power Speech Controller provides around 128 seconds of speech time
- Interface to Light, Sound, Temperature and Humidity sensor for controlling application.
- Use external SRAM or Flash RAM for recording function.



D. Pin Assignment

Pin	Pin Name	I/O	Function	Description
15 14	FXI, FXO	B, O	External Fast Clock pin. Connecting to crystal or RC to generate 32.768KHz ~ 8MHz frequency.	Mask Option settings : MO_FCK/SCKN=00 : Slow Clock only 01 : Illegal 10 : Dual Clock 11 : Fast Clock only MO_FOSCE=0 : Internal fast oscillation 1 : External fast oscillation
18 17	SXI, SXO	I, O	External Slow Clock pin. Connecting with 32768Hz crystal or resistor as slow clock and providing clock source for LCD display, TIMER1, Time-Base and other internal blocks.	MO_FXTAL=0 : RC osc. for Fast Clock 1 : X'tal osc. for Fast Clock MO_SXTAL=0 : RC for 32768Hz Clock 1 : X'tal for 32768Hz Clock Use OP1 and OP2 to switch among different operation mode (NORMAL, SLOW, IDEL and SLEEP). In Dual Clock mode, the main system clock is still the Fast Clock. The 32768Hz clock is for LCD and Timer 1 only.
13	RSTP_N	I	System reset signal	Level trigger, active low. Except for using this pin, using mask option (MO_PORE=1) could enable IC build-in power-on reset circuit. Besides, MO_WDTE can set Watch Dog Timer : MO_WDTE =0 : Disable Watch Dog Timer =1 : Enable Watch Dog Timer
16	TSTP_P	I	Test Pin.	Please bond this pin and add a test point on PCB for debugging. Leave this pin floating is OK.
28.. 35	PRTC[7:0]	B	8-pin bi-directional I/O port.	Mask Option MO_CPP[7:0] =1 : Push-pull = 0 : Open-drain. Output must be "1" before reading whenever use them as input (No tri-state structure).
20.. 27	PRTD[7:0]	B	8-pin bi-directional I/O port. PRTD[7..2] as wake-up pin. PRTD[7..6] as external interrupt pin.	Mask Option MO_DPP[7:0] =1 : Push-pull = 0 : Open-drain. Output must be "1" before reading whenever use them as input (No tri-state structure).
36	PWMP	O	PWM positive output can drive speaker or buzzer directly.	Set the bit-2 of VOC register (PWM =1) to turn on the PWM
37	PWMN	O	PWM negative output can drive speaker or buzzer directly.	Set the bit-2 of VOC register (PWM =1) to turn on the PWM.
8	VO	O	D/A voice output	Set the bit-1 of VOC register (VO =1) to turn on the VO.
9	DAO	O	D/A output, for OP use	Set the bit-0 of VOC register (DAO =1) to turn on the DAO.
10	OPIN	I	Negative input of OP comparator	Individual internal Op-Amp.
11	OPIP	I	Positive input of OP comparator	
12	OPO	O	Output of OP comparator	



19	VDD	P	Positive Power Input	Adding 0.1mF capacitor as by-pass capacitor is between VDD and GND is necessary
38	GND	P	Power Ground Input	

E. Pin Diagram

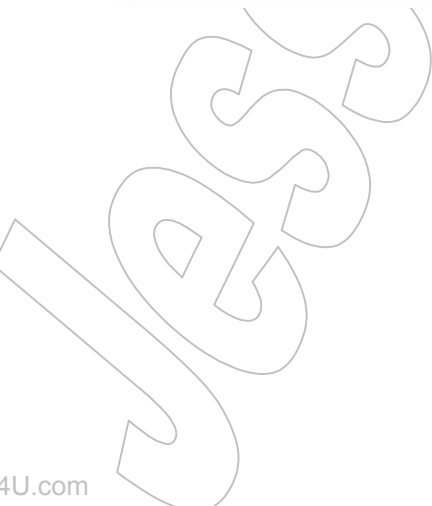
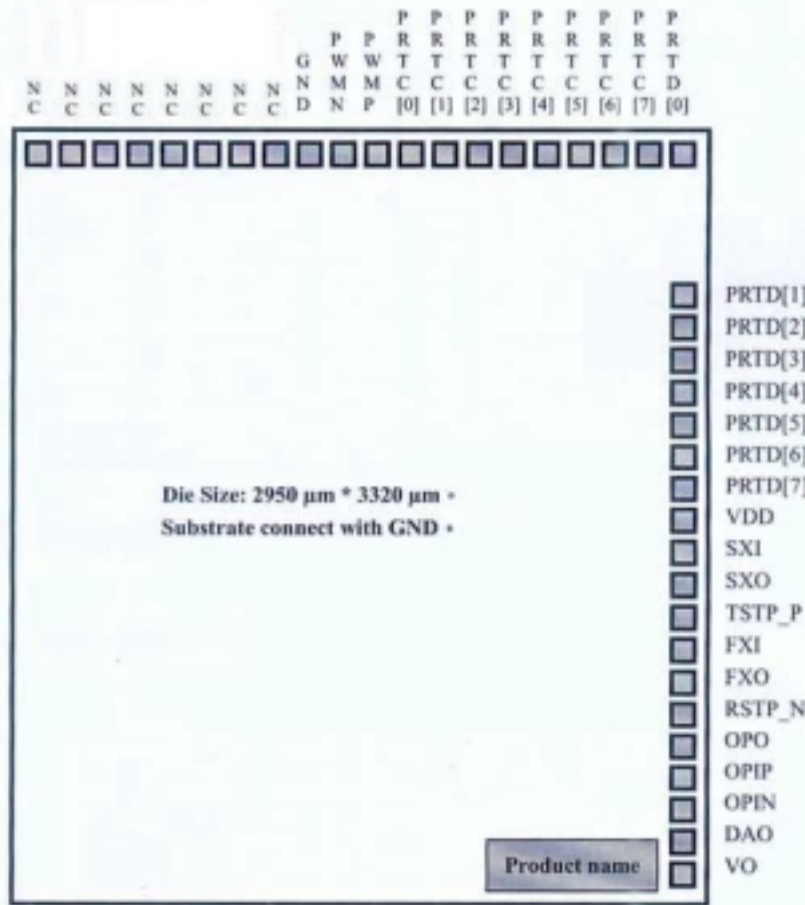



F. Bonding Pad Location

PIN Number	PIN Name	X Coordinate	Y Coordinate	PIN Number	PIN Name	X Coordinate	Y Coordinate
1	NC	X= -544.55	Y= 1562.60	21	PRTD[6]	X= 1375.50	Y= 254.15
2	NC	X= -681.50	Y= 1562.60	22	PRTD[5]	X= 1375.50	Y= 391.10
3	NC	X= -818.45	Y= 1562.60	23	PRTD[4]	X= 1375.50	Y= 528.05
4	NC	X= -955.40	Y= 1562.60	24	PRTD[3]	X= 1375.50	Y= 665.00
5	NC	X= -1092.35	Y= 1562.60	25	PRTD[2]	X= 1375.50	Y= 801.95
6	NC	X= -1229.30	Y= 1562.60	26	PRTD[1]	X= 1375.50	Y= 938.90
7	NC	X= -1366.25	Y= 1562.60	27	PRTD[0]	X= 1298.20	Y= 1562.60
8	VO	X= 1375.50	Y= -1540.20	28	PRTC[7]	X= 1161.25	Y= 1562.60
9	DAO	X= 1375.50	Y= -1388.40	29	PRTC[6]	X= 1014.70	Y= 1562.60
10	OPIN	X= 1375.50	Y= -1252.30	30	PRTC[5]	X= 877.75	Y= 1562.60
11	OPIP	X= 1375.50	Y= -1115.35	31	PRTC[4]	X= 740.80	Y= 1562.60
12	OPO	X= 1375.50	Y= -978.40	32	PRTC[3]	X= 603.85	Y= 1562.60
13	RSTP_N	X= 1375.50	Y= -841.45	33	PRTC[2]	X= 466.90	Y= 1562.60
14	FXO	X= 1375.50	Y= -704.50	34	PRTC[1]	X= 329.95	Y= 1562.60
15	FXI	X= 1375.50	Y= -567.55	35	PRTC[0]	X= 193.00	Y= 1562.60
16	TSTP_P	X= 1375.50	Y= -421.60	36	PWMP	X= 43.25	Y= 1562.60
17	SXO	X= 1375.50	Y= -293.65	37	PWMN	X= -120.10	Y= 1562.60
18	SXI	X= 1375.50	Y= -156.70	38	GND	X= -270.65	Y= 1562.60
19	VDD	X= 1375.50	Y= -19.75	39	NC	X= -407.60	Y= 1562.60
20	PRTD[7]	X= 1375.50	Y= 117.20				



G. Electrical Characteristics

Absolute Maximum Rating

Item	Sym.	Rating	Condition
Supply Voltage	V_{dd}	-0.5V ~ 8V	
Input Voltage	V_{in}	-0.5V ~ $V_{dd}+0.5V$	
Output Voltage	V_o	-0.5V ~ $V_{dd}+0.5V$	
Operating Temperature	T_{op}	0°C ~ 70°C	
Storage Temperature	T_{st}	-50°C ~ 100°C	

Recommended Operating Conditions

Item	Sym.	Rating	Condition
Supply Voltage	V_{dd}	2.4V ~ 5.2V	
Input Voltage	V_{ih}	0.9 V_{dd} ~ V_{dd}	
	V_{il}	0.0V ~ 0.1 V_{dd}	
Operating Frequency	Fmax	8MHz	$V_{dd}=5.0V$
		4MHz	$V_{dd}=2.4V$
Operating Temperature	T_{op}	0°C ~ 70°C	
Storage Temperature	T_{st}	-50°C ~ 100°C	



Test condition: TEMP=25°C, VDD=3V+/-10%, GND=0V

	PARAMETER		CONDITION	MIN	TYP	MAX	UNIT
I_{Fast}	NORMAL Mode Current	System	2M ext. R/C		0.75	1	mA
I_{Slow}	SLOW Mode Current	System	32.768K X'tal		6	9	μA
I_{Idle}	IDLE Mode Current	System	32.769K X'tal		4	7	μA
I_{Sleep}	Sleep Mode Current	System				1	μA
I_{oHPW}	PWM Output Drive Current	PWMP, PWMN*2	$V_{DD}=3V; V_{oh}=2V$	12	15		mA
I_{oLPW}	PWM Output Sink Current	PWMP, PWMN*2	$V_{DD}=3V; V_{ol}=1V$	33	40		mA
I_{oVO}	DAC Output Current	VO, DAO	$V_{DD}=3V; VO=0\sim 2V, Data=7F$	2.5	3		mA
V_{iH}	Input High Voltage	I/O pins		0.8			V
				V_{DD}			
V_{iL}	Input Low Voltage	I/O pins				0.2	V
						V_{DD}	
V_{hys}	Input Hysteresis Width	I/O, RSTP_N	Threshold=2/3 V_{DD} (input from low to high) Threshold=1/3 V_{DD} (input from high to low)		1/3		V
					V_{DD}		
I_{oH}	Output Drive Current	I/O pull-high*1	$V_{ol}=2.0V$	50			μA
I_{oL1}	Output Sink Current	I/O pull-low*1	$V_{ol}=0.4V$	1.0			mA
I_{iL1}	Input Low Current	RSTP_N	$V_{iL}=GND$, pull high Internally		20		μA
I_{iL2}	Input Low Current	I/O	$V_{iL}=GND$, if pull high Internally by user		100		μA

Note: *1: Drive Current Spec. for Push-Pull I/O port only

Sink Current Spec. for both Push-Pull and Open-Drain I/O port.

*2: This Spec. base on one driver only. There are five build-in driver, so user just multiply the number of driver he used to one driver current

 to get the total amount of current. ($I_{oHPWM} \cdot I_{oLPWM} * N$; N=0,1,2,3,4,5)

H. Application Circuit

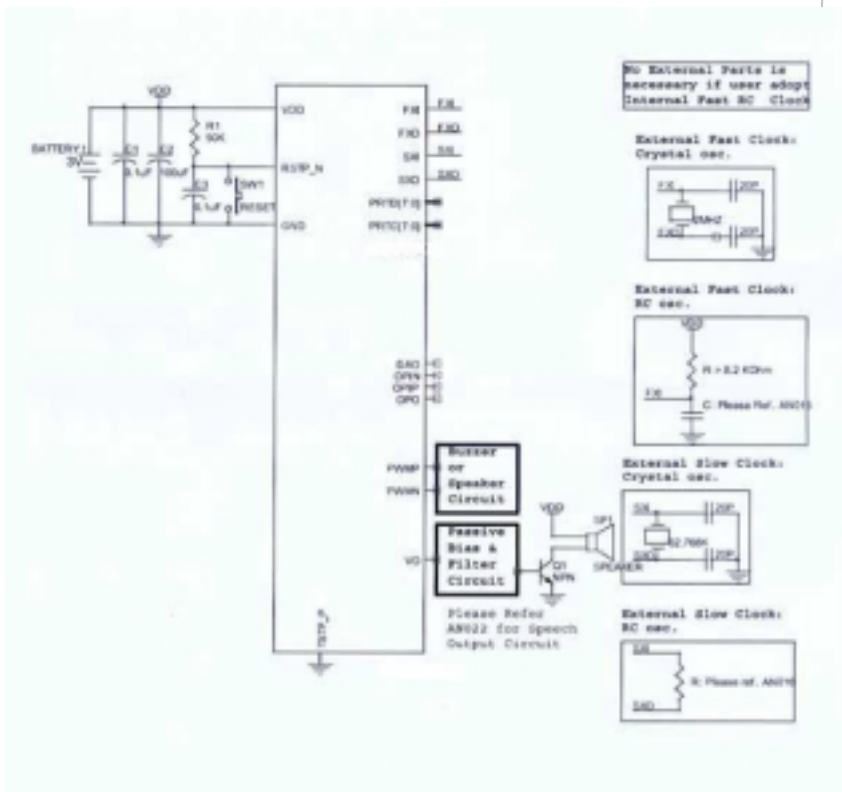

I. Important Note

For accessing any address large than 64KB, users must update TPP first, TPH then TPL. Only by this order, the pre-charge circuit of ROM will work correctly. 5us waiting is necessary before LDV instruction is executed since Data ROM is a low speed ROM. Users can not emulate this accessing process in ICE. So 5us delay should be added by firmware.

Please bonds the TSTP_P, RSTP_N and PRTD[7:0] with test point on PCB (can be soldered and probed) as you can, then JESS can do some IC testing job on PCB. Neither VDD nor GND connection is necessary for TSTP_P. The following figure is an example (Testing point with through hole.)

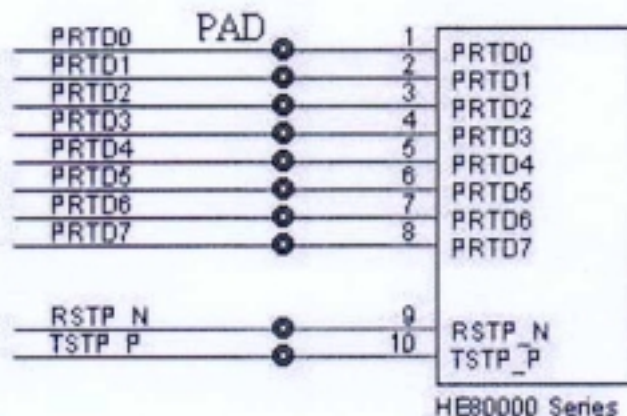

SUPPLEMENTARY SPECIFICATION: HE80 Series PWM application

Description:

For HE80 PWM application, the following points must be bare in mind.

1. The PWM output can direct drive buzzer.
2. For direct drive speaker, it must use 32Ω or above speaker.
3. For speaker application, it must add capacitors between IC's VDD ground and its PWM output, see below figure.

Note: the 1uF capacitor must be connected near IC's

