

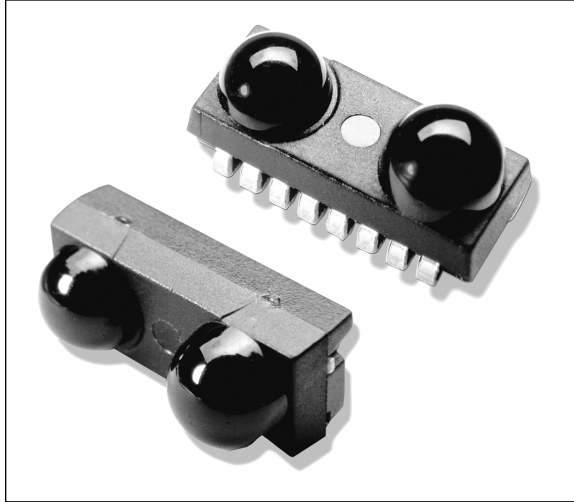

SIDE VIEW IRMS6452/TOP VIEW IRMT6452

4 Mb/s Infrared Data Transceiver

Preliminary

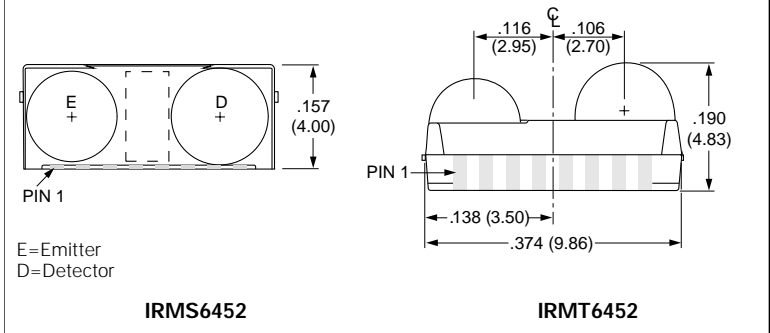

Dimensions in inches (mm)

**Features**

- IrDA, HP-SIR, Local Talk and Sharp ASK
- Ultracompact package:
- H 4.0 mm x D 4.8 mm x L 9.8 mm
- Data rates from 9.6 Kbit/s to 4 Mbit/s
- Supply voltage 2.7 V to 5.25 V
- Power Shutdown mode (<100 nA)
- Low power consumption
 - 1.7 mA (typ) @ 2.7 V
 - 3.2 mA (typ) @ 5.0 V
- Zero external resistors required

Description

Responding to the volumetric constraints of today's ultra-compact and power conscious portable products, Vishay has developed the next generation in infrared wireless communication transceivers. The transceiver has been designed to support up to 4 Mbit/s IrDA™, HP-SIR™, Local Talk™ and Sharp ASK™ modes. The device combines an LED, photodiode, LED driver and a fully differential receiver into a single integrated package.

Absolute Maximum Ratings, $T_A=25^\circ\text{C}$ (except where noted)

Supply Voltage Range, all states, V_{CC} -0.5 to +5.5 V
 Storage Temperature, T_{STG} -25 to +85°C
 Ambient Temperature, operating, T_A -25 to +75°C
 Lead Solder Temperature, 240°C<10 s
 IC Junction Temperature, T_J 125°C
 Average IR LED Current, DC, I_{LED} 100 mA
 Repetitive Pulsed IR LED Current,
 <90 μs , ton <25%, $I_{LED(RP)}$ 710 mA
 Transmit Data Input Voltage, V_{TXD} -0.5 to $V_{CC} + 0.5$ V
 Receive Data Output Voltage, V_{RXD} -0.5 to $V_{CC} + 0.5$ V

Pin Number	Symbol	Description
1	LEDA	LED Anode
2	LEDC	LED Cathode
3	TxD	Transmit Data
4	RxD	Receive Data
5	SD/ Mode	Shutdown/ Mode Select
6	V_{CC}	Positive Supply (Power)
7	NC	GND
8	GND	Ground

Table 1. Input/Output Functional Description

Symbol	I/O Type	Polarity	Function
RxD	Output	Active Low	This output indicates received serial data. It is a push-pull CMOS driver capable of driving a standard CMOS or TTL load. No external pull-up or pull-down resistor is required. This output may switch indeterminately when the module is transmitting. This output pin is in tri-state mode when the module is in shutdown mode and during digital serial programming operations. RxD is high at initialization.
TxD	Input	Active High	This CMOS input is used to transmit serial data when SD/ Mode is low. An on-chip protection circuit disables the LED driver if the TxDPin is asserted for longer than 60 μ s. When used in conjunction with the SD/ Mode pin, TxD is low at initialization.
SD/ Mode	Input	Active High	Assertion of this pin high for a period of time exceeding 400 μ s places the module into shutdown mode. On the falling edge of this signal, the state of the TxDPin is sampled and used to set receiver low bandwidth (TxD= Low) or high bandwidth (TxD= High) mode. See Figures 7 and 8 for timings. SD is low at initialization.
V _{CC}	Positive Supply	-	Connect to positive power supply (2.7 V to 5.25 V). Placement of a 1.0 μ F to 10.0 μ F decoupling ceramic capacitor as close as possible to the V _{CC} pin is recommended.
GND	Ground (Power)	-	Connect to power supply ground. A solid ground plane is recommended.
NC	No Connect	-	This pin could be connected to ground.
L _{EDA}	Input	-	This pin can be connected directly to V _{CC} . No series resistor is required.
L _{EDC}	Output	-	LED cathode. Leave this pin unconnected. This pin may be monitored to determine the state of the LED.

Figure 1. Block Diagram

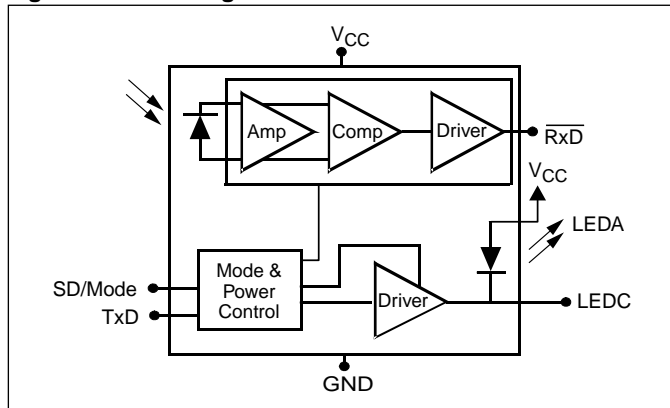

Figure 2. Minimum Vishay Low-Power Integrated Infrared Transceiver Circuit Diagram

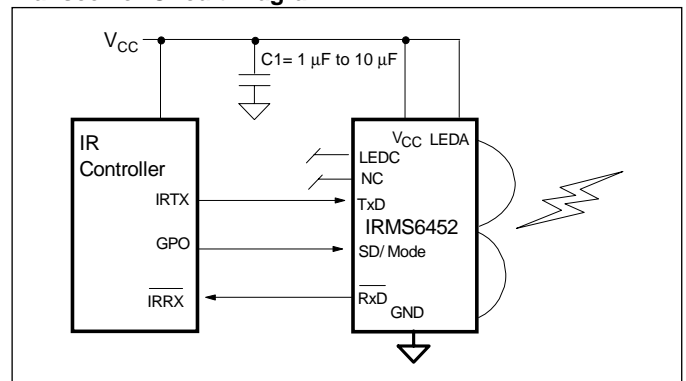

Table 2. Recommended Operating Conditions

Symbol	Parameter	Min	Typical	Max	Unit	Conditions
V _{CC}	Supply Voltage	2.7		5.25	V	
T _A	Ambient Operating Temperature	-25		75	°C	

Table 3. DC Electrical Characteristics

Symbol	Parameter	Min	Typical	Max	Unit	Conditions
I _{CC}	Supply Current; Listening	2.0	3.2	4.5	mA	Typical value obtained at V _{CC} =5 V
I _{CC}	Supply Current; Receiving		3.8	15	mA	Interface and optical input power dependent
I _{SD}	Supply Current; Shutdown		50	100	nA	V _{SD} =V _{CC}

Table 4. Receiver DC Electrical Characteristics

Symbol	Parameter	Min	Typical	Max	Unit	Conditions
V _{OL}	RxD Output Low Voltage			0.5	V	
I _{OL}	Static Sink Current on RxD			2.4	mA	2.2K Ω load.
V _{OH}	RxD Output High Voltage	V _{CC} -0.5			V	
I _{OH}	Static Source Current on RxD			2.4	mA	2.2K Ω load.
R _L	RxD Resistive Load	2.2			k Ω	
C _L	RxD Capacitive Load			50	pF	

Table 5. Transmitter DC Electrical Characteristics

Symbol	Parameter	Min	Typical	Max	Unit	Conditions
V _{IL}	TxD Input Voltage Low			0.8	V	
V _{IH}	TxD Input Voltage High	2.4			V	
C _i	Input Capacitance			5	pF	

Table 6. SD/Mode DC Electrical Characteristics

Symbol	Parameter	Min	Typical	Max	Unit	Conditions
V _{IL}	SD/ Mode Input Voltage Low			0.8	V	
V _{IH}	SD/ Mode Input Voltage High	2.4			V	
C _i	Input Capacitance			5	pF	

Table 7. Optical Characteristics

Symbol	Parameter	Min	Typical	Max	Unit	Conditions
E _{min}	Minimum Detection Irradiance 9.6-115.2 kbit/s, SIR		3.7	4	μW/cm ²	9.6 kbit/s to 115.2 kbit/s
E _{min}	Minimum Detection Irradiance 1.152Mbit/s, MIR		4		μW/cm ²	1.152 Mbit/s
E _{min}	Minimum Detection Irradiance 4 Mbit/s, FIR		7.9	9	μW/cm ²	4 Mbit/s
t _r , t _f	LED Optical Rise/Fall Time			40	ns	
t _{xpw}	SIR Optical Pulse Width	1.41		22.13	μs	TxD Input Pulse Width = 3/16 duty cycle
t _{xpw}	MIR Optical Pulse Width	147		261	ns	TxD Input Pulse Width = 217ns
t _{xpw}	FIR Optical Pulse Width	115		140	ns	TxD Input Pulse Width = 125ns
I _e	Output Radiant Intensity	110	200	400	mW/sr	TxD=High, SD/Mode=Low, V _{CC} =3.3 V, α = ±15°, T _A =25°C, TX@2MHz and 25%
α	Output Radiant Half Intensity Angle	±15			°	
λ _p	Peak Wavelength	850	870	900	nm	
	Optical Overshoot			25	%	

Table 8. AC Electrical Characteristics

Symbol	Parameter	Min	Typical	Max	Unit	Conditions
t _r	RxD Rise Time			60	ns	R _L =2.2 K, C _L =50 pF
t _f	RxD Fall Time			50	ns	R _L =2.2 K, C _L =50 pF
t _{SU} , t _H	TxD Setup and Hold to SD/ Mode Falling Edge	10			ns	
t _w	RxD Pulse Width (SIR)	1.0		2.1	μs	
t _w	RxD Pulse Width (1.152Mbit/s)	100		600	ns	
t _w	RxD Pulse Width (4Mbit/s, single pulse)	80		165	ns	
t _w	RxD Pulse Width (4Mbit/s, double pulse)	210		290	ns	
t _L	Receiver Latency			100	μs	
t _{RxDEN}	RxD Valid After Shutdown			200	μs	
t _{LEDP}	LED Protection Time-out			100	μs	
I _{LED}	Peak Transmit Current	10		710	mA	25% duty cycle
I _{LED}	Average Transmit Current	5		150	mA	25% duty cycle

Figure 3. Timing Diagrams

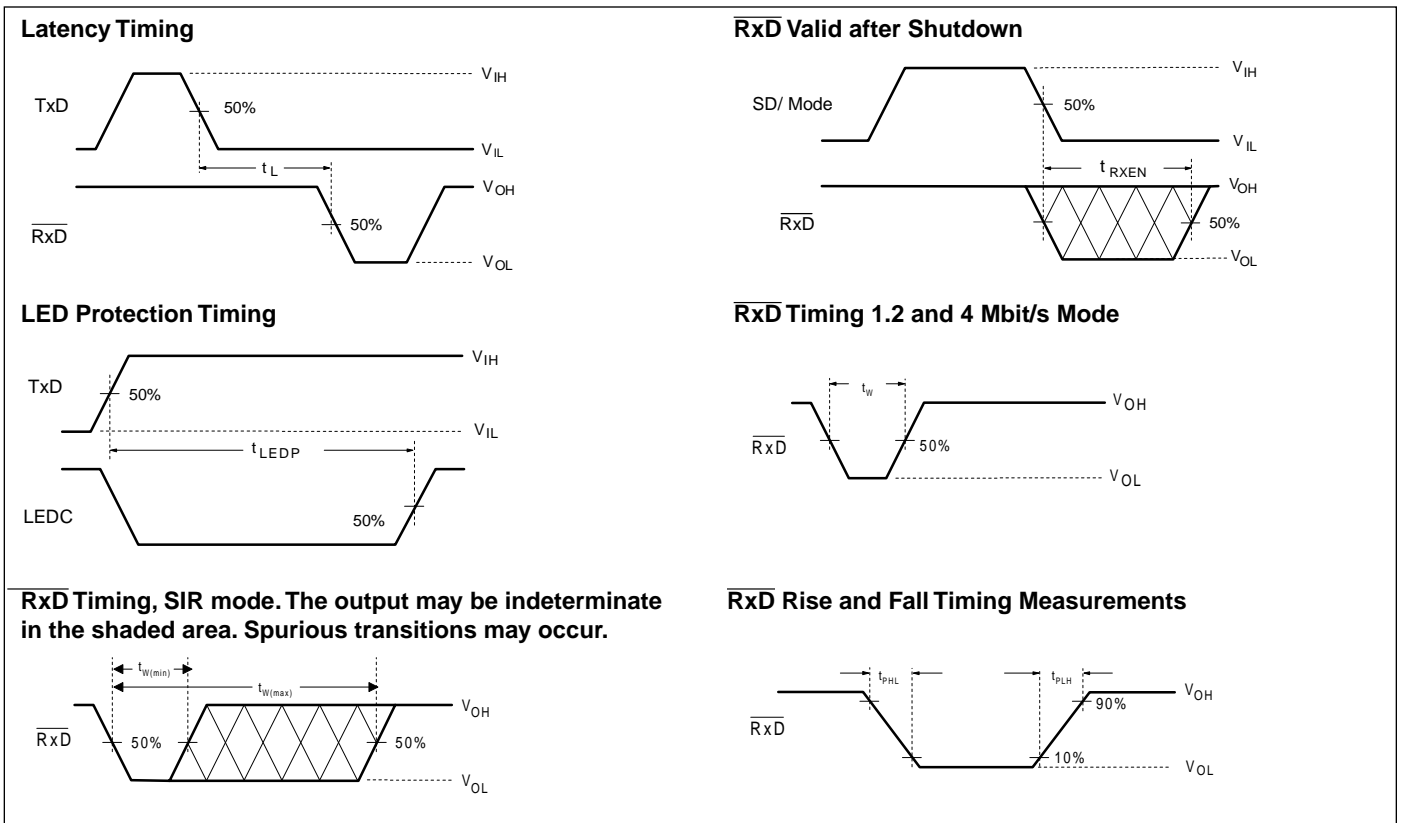
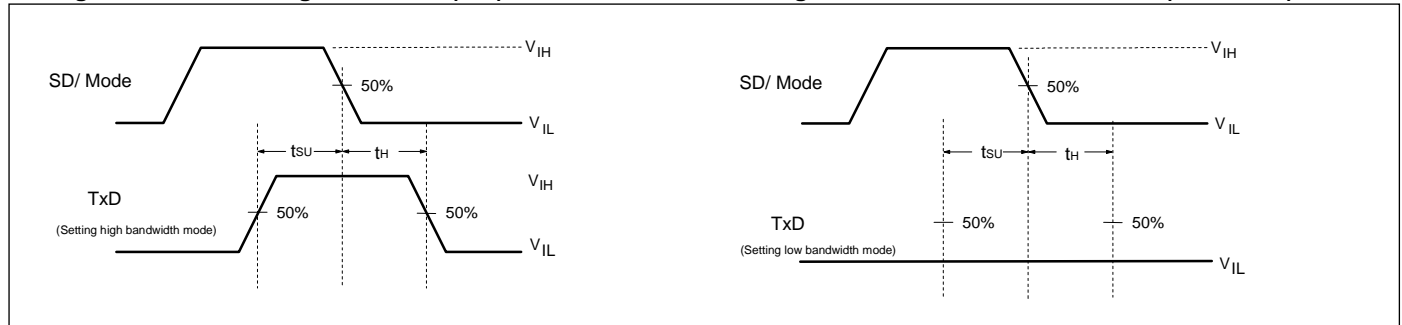

Figure 4. Bandwidth Programming

Setting the Receiver to High BW Mode (FIR)

Setting the Receiver to Low BW Mode (SIR & MIR)



The transceiver powers on with the receiver in low bandwidth mode. To enable high bandwidth mode, apply timings as shown in the figure 7, to the SD/ Mode and the TxD inputs. Note that the internal LED driver is disabled when SD/ Mode is active and is not enabled until the next rising edge of TxD. This ensures that the LED will not be active during bandwidth adjustment. It is recommended that the SD/ Mode pin be connected to GND if bandwidth adjustment and shutdown mode are not used.

Setting the Receiver to High Bandwidth Mode (see Figure 4)

1. Set the SD/ Mode input to 'logic high'.
2. Set the TxD input to 'logic high'. Wait $t_{su} \geq 10$ ns.
3. Set the SD/ Mode to 'logic low'. (This high-to-low transition latches the state of TxD, which determines the receiver bandwidth.)

4. After waiting $t_h \geq 10$ ns, set the TxD input to 'logic low'. The receiver is in high bandwidth mode within 200 μ s of the SD/ Mode rising edge or 10 ns after the SD/ Mode falling edge, whichever occurs later.

Setting the Receiver to Low Bandwidth Mode (see Figure 4)

1. Set the SD/ Mode input to 'logic high'.
2. Ensure that the TxD input is at 'logic low'. Wait $t_{su} \geq 10$ ns.
3. Set the SD/ Mode to 'logic low'. (This high-to-low transition latches the state of TxD, which determines the receiver bandwidth.)
4. Ensure that the TxD input remains low for $t_h \geq 10$ ns. The receiver is in low bandwidth mode within 200 μ s of the SD/ Mode rising edge or 10 ns after the SD/ Mode falling edge, whichever occurs later.

Figure 5. Infrared Reflow Soldering Profile

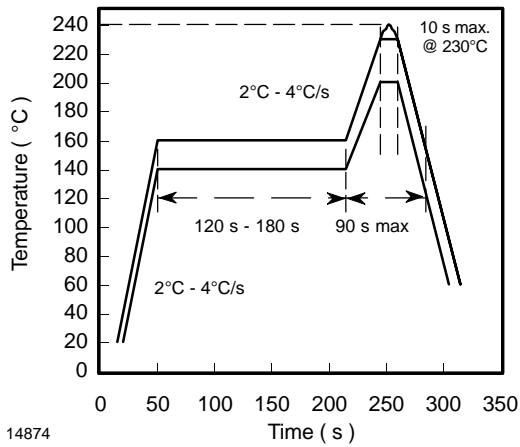

Figure 6. Super I/O (PC87338VLJ) to IRMS6452/IRMT6452

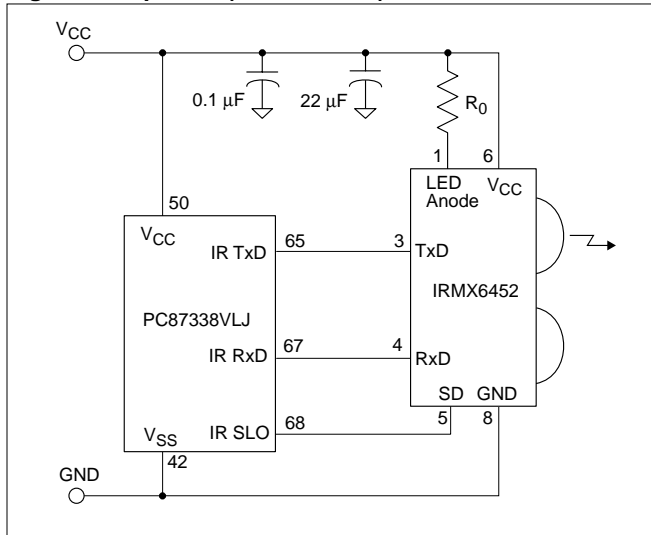

Figure 7. Ultra I/O controller with fast IR (FDC37C93xFR) to IRMS6452/IRMT6452

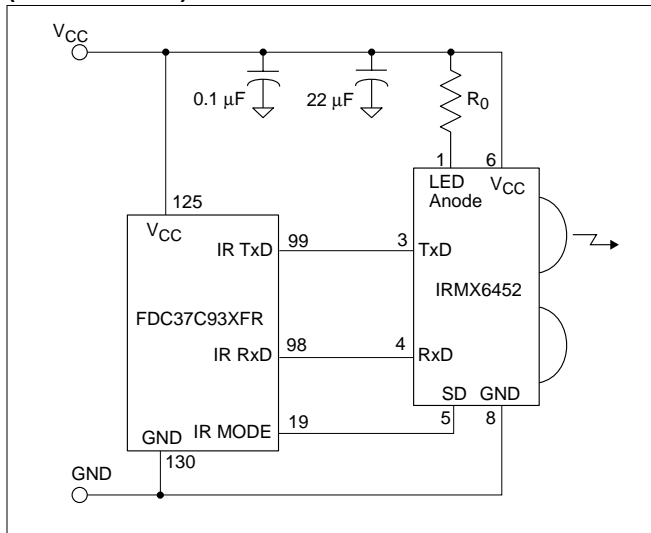

Figure 8. Super I/O (PC87338VLJ) to IRMS6452/IRMT6452 with independent V_{LED} power supply

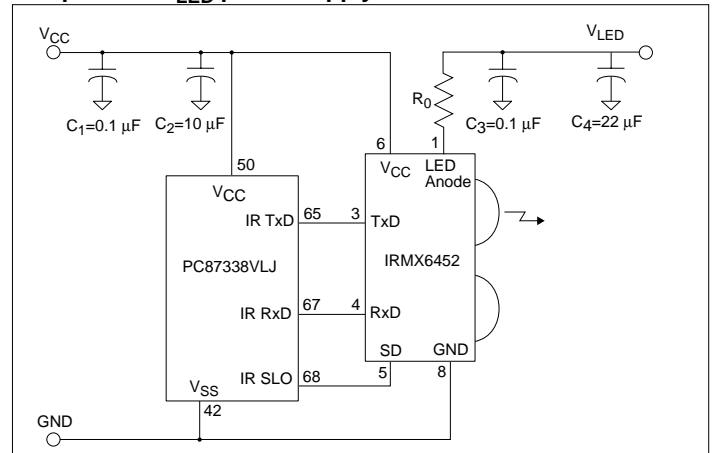

Table 9. Recommended R₀ values for different V_{LED}

Parameter	Values				Unit
V _{LED} power supply	2.7	3	3.3	>3.5	V
Resistor	0	1.8	4.7	6.8	Ω

Table 10. Slimline IRMS64XX Truth Table

Inputs				Outputs	
SD	V _{CC}	RxD	Detector	RxD	LED
High	2.4 to 5.5 V	X=don't care state	X=don't care state		Off
Low	2.4 to 5.5 V	High			On
	2.4 to 5.5 V	Low	<0.4 μW/cm ² (115 Kb/s)	High	Off
	2.4 to 5.5 V		<1.0 μW/cm ² (1 & 4 Mb/s)		
	2.4 to 5.5 V	Low	<4.0 μW/cm ² (115 Kb/s)	Low	Off
	2.4 to 5.5 V		<10.0 μW/cm ² (1 & 4 Mb/s)		

Figure 11. IRMS6452/IRMT6452 detail drawings with optional side view or top view mounting

Dimensions in inches (mm)—All dimensions have tolerances of ± 0.004 " (± 0.1 mm)

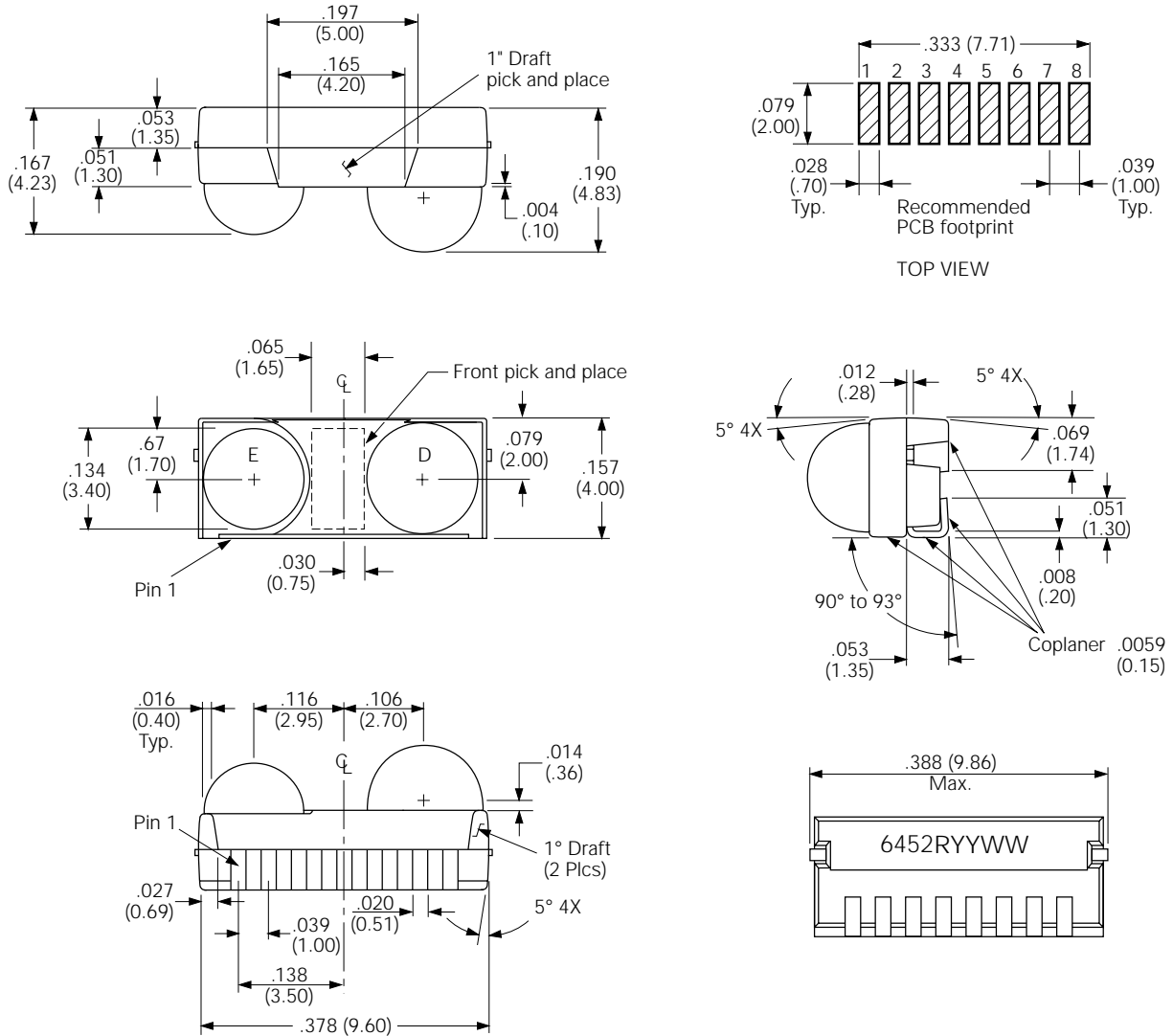

Vishay reserves the right to make changes to the product described without notice. No liability is assumed as a result of its use nor for any infringement of the rights of others.

This document may contain preliminary information and is subject to change by Vishay without notice. Some of the parametric data expressed in this preliminary data sheet is considered to be functional by design. Vishay assumes no responsibility or liability for any use of the information contained herein. Nothing in this document shall operate as an express or implied license or indemnity under the intellectual property rights of Vishay or third parties.

The products described in this document are not intended for use in implantation or other direct life support applications where malfunction may result in the direct physical harm or injury to persons.

NO WARRANTIES OF ANY KIND, INCLUDING, BUT NOT LIMITED TO, THE IMPLIED WARRANTIES OF MERCHANTABILITY OF FITNESS FOR A PARTICULAR PURPOSE, ARE OFFERED IN THIS DOCUMENT.

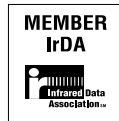

© Vishay Infrared Components, Inc.

Printed in the United States of America.

All rights reserved. Vishay

The information provided is believed to be accurate and reliable.

Document Number: 82579

Revision 05-July-02

www.vishay.com