

Single Channel PCM / ADPCM Codec

CP1306_PB_Rev1.0, March,2005

OVERVIEW

- The CP1306 is a single channel PCM / ADPCM codec fabricated in advanced low-power mixed-mode CMOS process. The CP1306 encodes the analog voice band signal to 64 Kbps PCM (G.711) or 32 Kbps ADPCM (G.721) serial data, and decodes 64 Kbps PCM (G.711) or 32 Kbps ADPCM (G.721) serial data to analog voice band signal. Its transmit/receive data mute, gain, side-tone attenuation, 12 dB loss PAD at receive side and power down mode are programmable through a serial microcontroller interface.

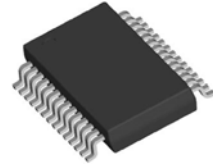

SSOP30
-40°C ~ 85°C

FEATURES

- 1 channel PCM / ADPCM codec with Digital Signal Processing(DSP) technique
- Voice companding algorithm:
 - ITU-T G.711 PCM (μ -law) @ 64 Kbps
 - ITU-T G.721 ADPCM @ 32 Kbps
- Transmit/Receive synchronous mode only
- Sampling frequency: $f_{\text{SYNC}} = 8 \text{ KHz}$
- Master clock frequency: $f_{\text{MCLK}} = f_{\text{SYNC}} \times 1296$
- Serial PCM/ADPCM transmission data rate from 64 Kbps to 2048 Kbps
- Programmable digital filters to adapt transmission behaviors:

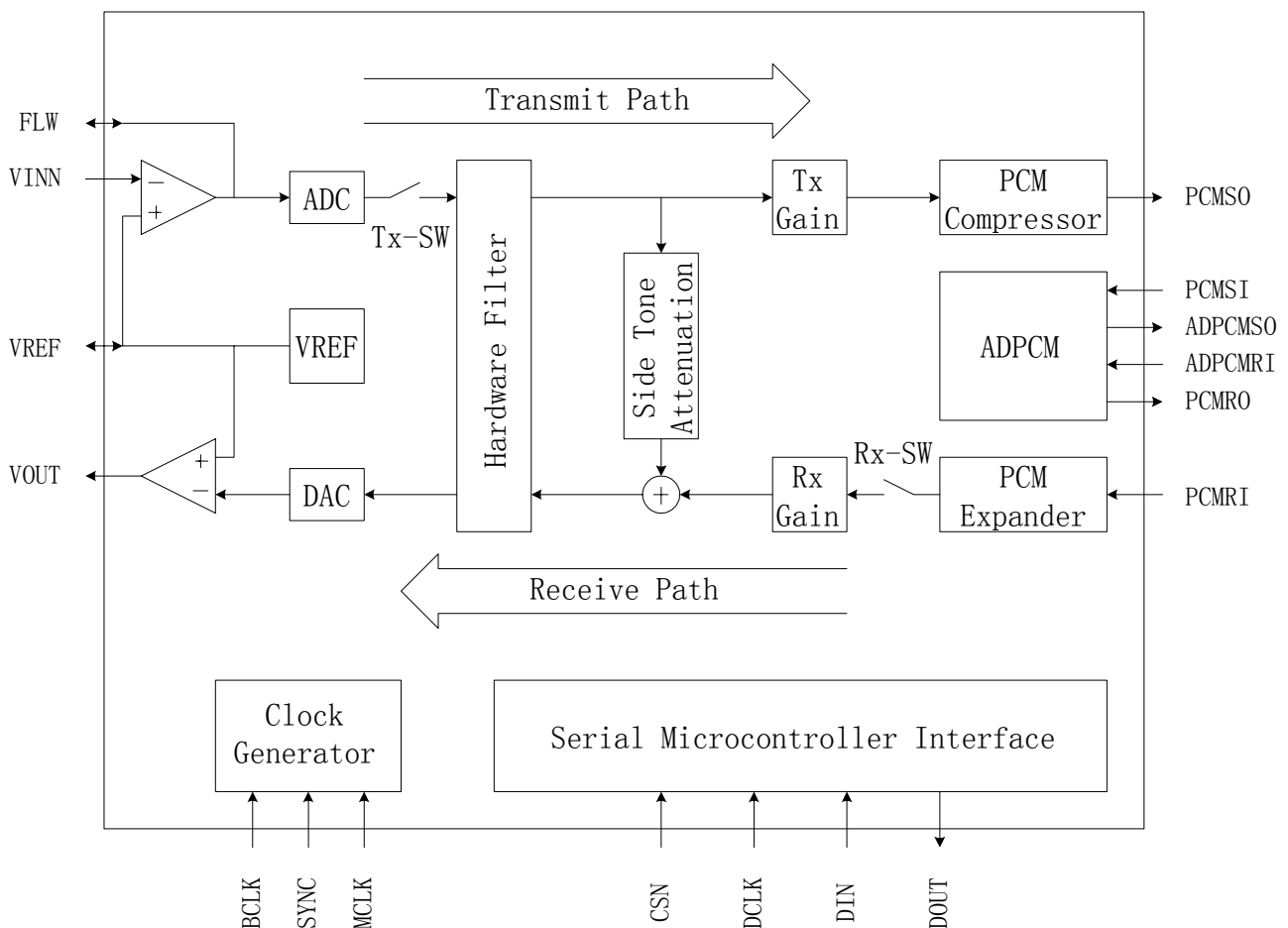



Single Channel PCM / ADPCM Codec

CP1306_PB_Rev1.0, March,2005

- Transmit/Receive mute
- Transmit/Receive gain
- Side tone path attenuation
- 12dB loss PAD at receive side
- Power-down mode
- On-chip precision reference voltage ($V_{ref}=1.4V \pm 50mV$)
- Single 3V power supply (Min=2.7V, Max=3.6V)
- Low power consumption:
 - In working mode: $I_{dd} = 8mA$ (typ)
 - In power down mode: $I_{dd} = 0.01mA$ (typ)
- Serial microcontroller interface
- Operating industrial temperature range: $-40^{\circ}C \sim 85^{\circ}C$
- SSOP30 package

APPLICATIONS

- Central office switch and PBXs
- Digital cordless telephony systems
- Voice over IP (VoIP)

TYPICAL APPLICATION

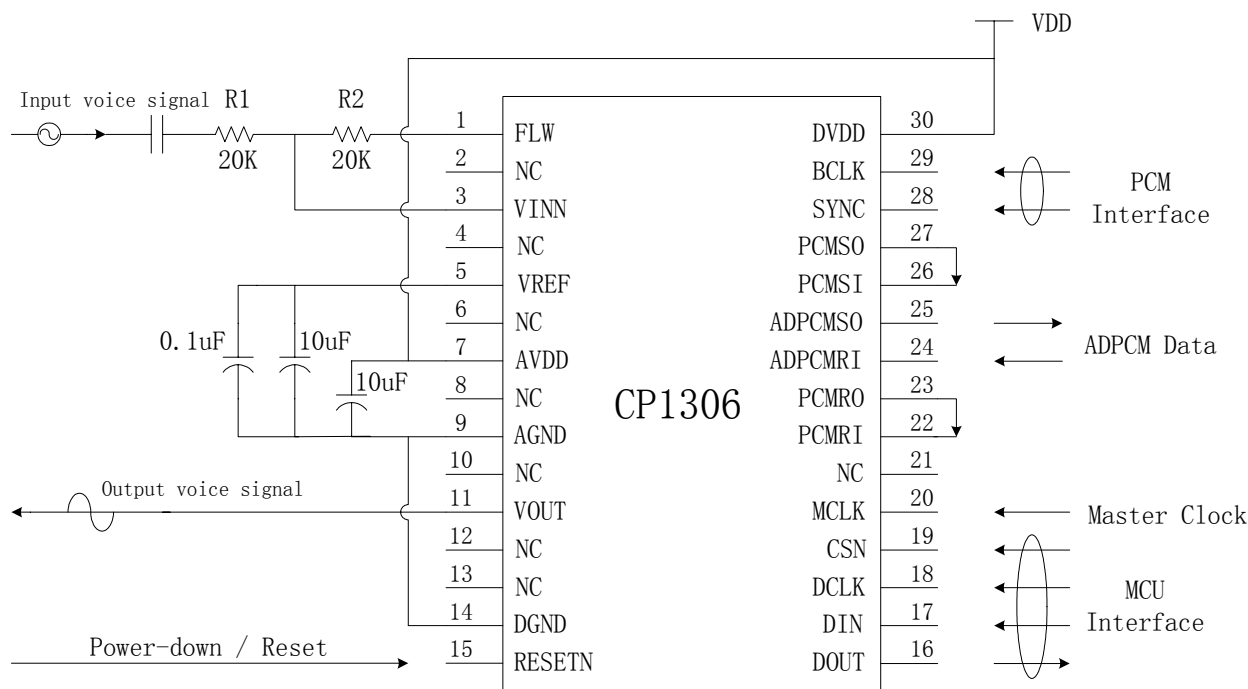

Chiphomer Technology Limited
 Add: 4F, Building D, 1618 Yishan Road, Shanghai, P.R.C.
 Tel: +86-(0)21-64058488, 64014543
 Fax: +86-(0)21-64050030
 Email: sales@chiphomer.com
 Web: www.chiphomer.com