



JUNE 1996

Features

CONVERSION LOSS: 11 dB

LO TO RF AND IF ISOLATION: > 30 dB

SUITABLE FOR PCN BAND APPLICATIONS

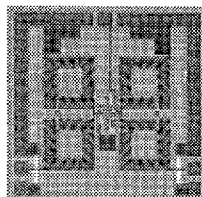

**Typical Performance
at a Fixed 250 MHz IF**

General Description

The HMC128 chip is a miniature double-balanced mixer which can be used as an upconverter or downconverter. The chip is especially suitable for portable wireless applications because of its small size and zero DC bias requirement.

Schematic

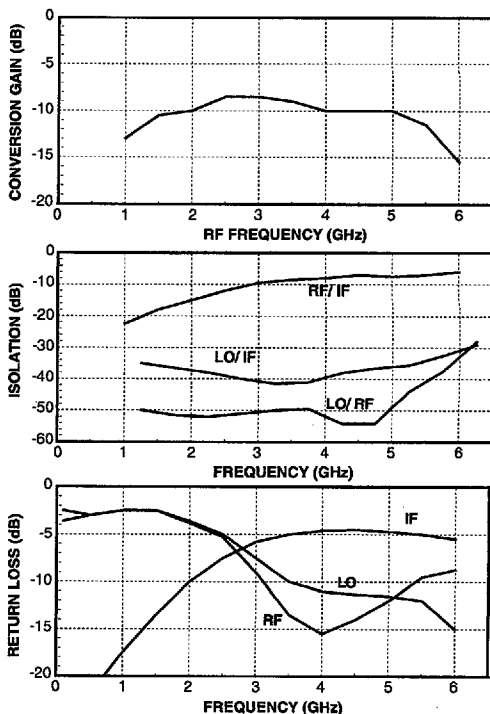
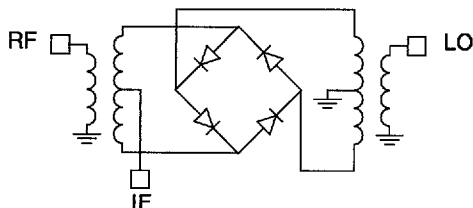

**Electrical Performance
(With LO Drive of +15 dBm)**

Parameter	Min.	Typ.	Max.	Units
Frequency Range, RF & LO		1.8 - 5.0		GHz
Frequency Range, IF		DC - 2		GHz
Conversion Loss		10	11	dB
Noise Figure (SSB)		10	11	dB
LO to RF Isolation	35	50		dB
LO to IF Isolation	25	35		dB
IP3 (Input)	13	18		dBm
IP2 (Input)	35	40		dBm
1 dB Gain Compression (Input)	5	10		dBm
Local Oscillator Drive Level	10	15	20	dBm



JUNE 1996

Handling Precautions

Follow these precautions to avoid permanent damage.

Cleanliness: Handle the chips in a clean environment. DO NOT attempt to clean the chip using liquid cleaning systems.

Static Sensitivity: Follow ESD precautions.

Transients: Suppress instrument and bias supply transients while bias is applied. Use shielded signal and bias cables to minimize inductive pick-up.

General Handling: Handle the chip along the edges with a vacuum collet or with a sharp pair of bent tweezers. The surface of the chip has fragile air bridges and should not be touched with vacuum collet, tweezers, or fingers.

Mounting

The chip is back-metallized and can be die mounted with AuSn eutectic preforms or with electrically conductive epoxy. The mounting surface should be clean and flat.

Eutectic Die Attach:

A 80/20 gold tin preform is recommended with a work surface temperature of 255 deg. C and a tool temperature of 265 deg. C. When hot 90/10 nitrogen/hydrogen gas is applied, tool tip temperature should be 290 deg. C.

DO NOT expose the chip to a temperature greater than 320 deg. C for more than 20 seconds. No more than 3 seconds of scrubbing should be required for attachment.

Epoxy Die Attach:

Apply a minimum amount of epoxy to the mounting surface so that a thin epoxy fillet is observed around the perimeter of the chip once it is placed into position.

Cure epoxy per the manufacturer's schedule.

Wire Bonding

Ball or wedge bond with 1.0 diameter pure gold wire. Thermosonic wirebonding with a nominal stage temperature of 150 deg. C and a ball bonding force of 40 to 50 grams or wedge bonding force of 18 to 22 grams is recommended. Use the minimum level of ultrasonic energy to achieve reliable wirebonds.

Wirebonds should be started on the chip and terminated on the package. RF bonds should be as short as possible.

Absolute Maximum Ratings

LO Drive	+27 dBm
Storage Temperature	-65 to +150 deg C
Operating Temperature	-55 to +125 deg C

Outline Drawing

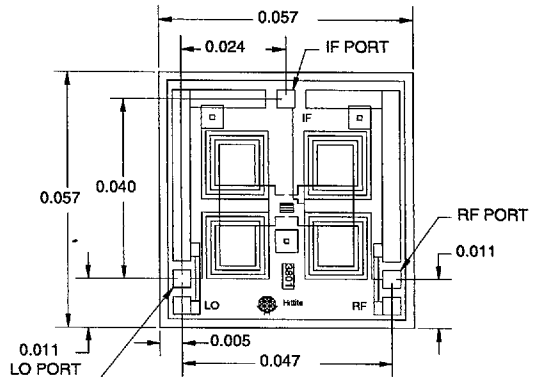

DIE THICKNESS IS 0.004, BACKSIDE IS GROUND
BONDPADS ARE 0.004 SQUARE
ALL DIMENSIONS IN INCHES, +/-0.001