



# IFE50-005 THRU IFE50-06

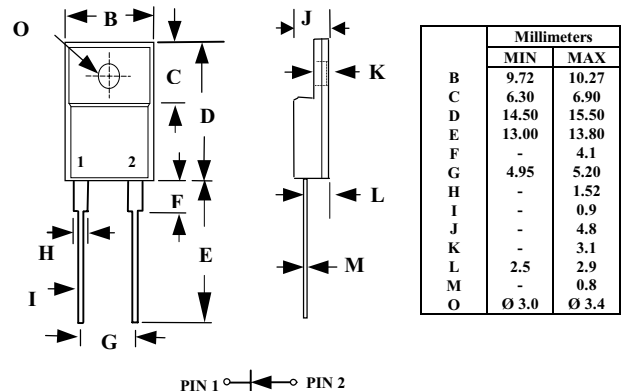
## 5A FAST EFFICIENT RECTIFIER

### FEATURES

- 1 Low power loss, high efficiency
- 1 Low forward voltage drop
- 1 High current capability
- 1 High speed switching
- 1 High reliability
- 1 High current surge
- 1 Glass passivated chip junction
- 1 Plastic material has UL flammability classification 94V-0

### MECHANICAL DATA

- 1 Case : JEDEC ITO-220 molded plastic.
- 1 Lead : Solderable per MIL-STD-202, method 208
- 1 Mounting position : Any
- 1 Weight : 1.81 grams



CASE: ITO-220

### MAXIMUM RATINGS AND ELECTRICAL CHARACTERISTICS

Ratings at 25°C ambient temperature unless otherwise specified  
single phase, half wave, 60 Hz, resistive or inductive load.  
For capacitive load, derate current by 20%

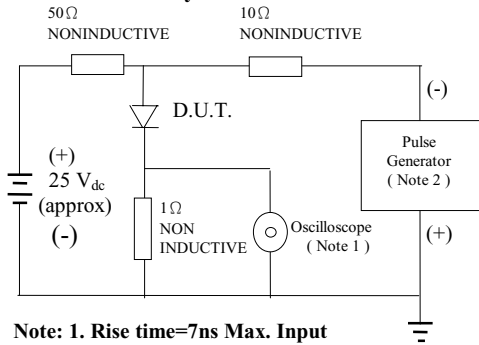
CHARACTERISTICS	SYMBOL	IFE50	IFE50	IFE50	IFE50	IFE50	IFE50	IFE50	UNITS
		-005	-01	-02	-03	-04	-05	-06	
Maximum Recurrent Peak Reverse Voltage	$V_{RRM}$	50	100	200	300	400	500	600	V
Maximum RMS Voltage	$V_{RMS}$	35	70	140	210	280	350	420	V
Maximum DC Blocking Voltage	$V_{DC}$	50	100	200	300	400	500	600	V
Maximum Average Forward Rectified Current	$I_O$	5.0							A
Peak Forward Surge Current, 8.3ms Single Half Sine-Wave Superimposed on Rated Load	$I_{FSM}$	125							A
Typical Junction Capacitance (Note 1)	$C_J$	85					50		pF
Typical Thermal Resistance (Note 2)	$R_{OJA}$	2.2							°C/W
Operating Temperature Range	$T_{OP}$	- 55 TO + 150							°C
Storage Temperature Range	$T_{STG}$	-55 TO + 150							°C
Maximum Forward Voltage at $I_O$ DC	$V_F$	0.98		1.25		1.85		V	
Maximum Reverse Current at $T_A = 25^\circ\text{C}$	$I_R$	10							µA
Maximum Reverse Current at $T_A = 100^\circ\text{C}$	$I_R$	100							µA
Maximum Reverse Recovery Time (Note 3)	$T_{RR}$	25							nS

#### NOTE :

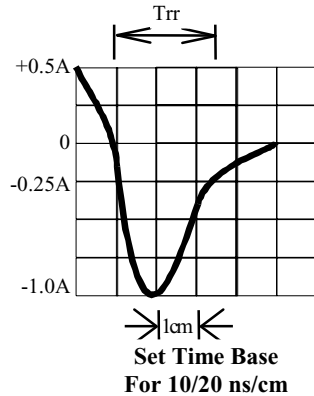
1. Measured at 1 MHz and applied reverse voltage of 4.0 volts
2. Both leads attached to heat sink 20x20x1t(mm) copper plate at lead length 5mm
3. Reverse recovery test conditions:  $I_F=0.5\text{A}$ ,  $I_R=1.0\text{A}$ ,  $I_{RR}=0.25\text{A}$

# RATINGS AND CHARACTERISTIC CURVE IFE50-005 THRU IFE50-06

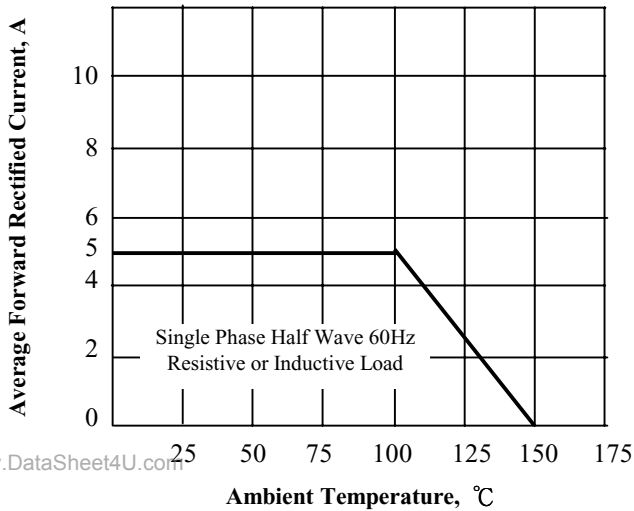
**Fig. 1 -Test Circuit Diagram And Reverse Recovery Time Characteristic**



Note: 1. Rise time=7ns Max. Input Impedance=1 Meg-ohm 22PF  
 2. Rise Time =10 ns Max. Source Impedance=50 ohms

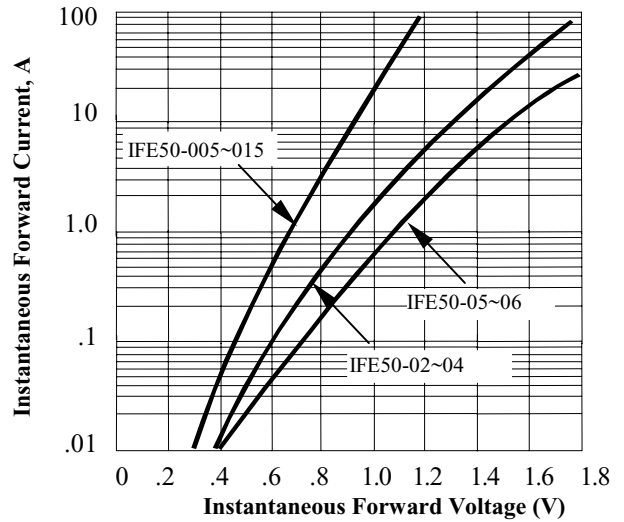


**Fig. 2 -Maximum Forward Current Derating Curve**

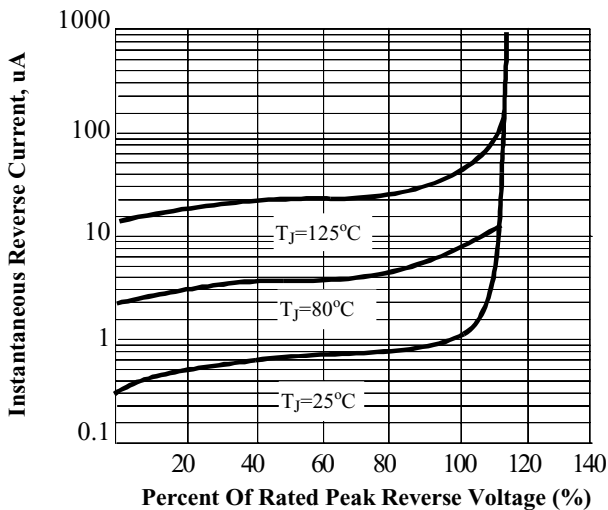


www.DataSheet4U.com

**Fig. 3 -Typical Instantaneous Forward Characteristics**



**Fig. 4 -Typical Reverse Characteristics**



**Fig. 5 -Typical Junction Capacitance**

