

# CHIP MONOLITHIC CERAMIC CAPACITOR

## CHIP MONOLITHIC CERAMIC CAPACITOR

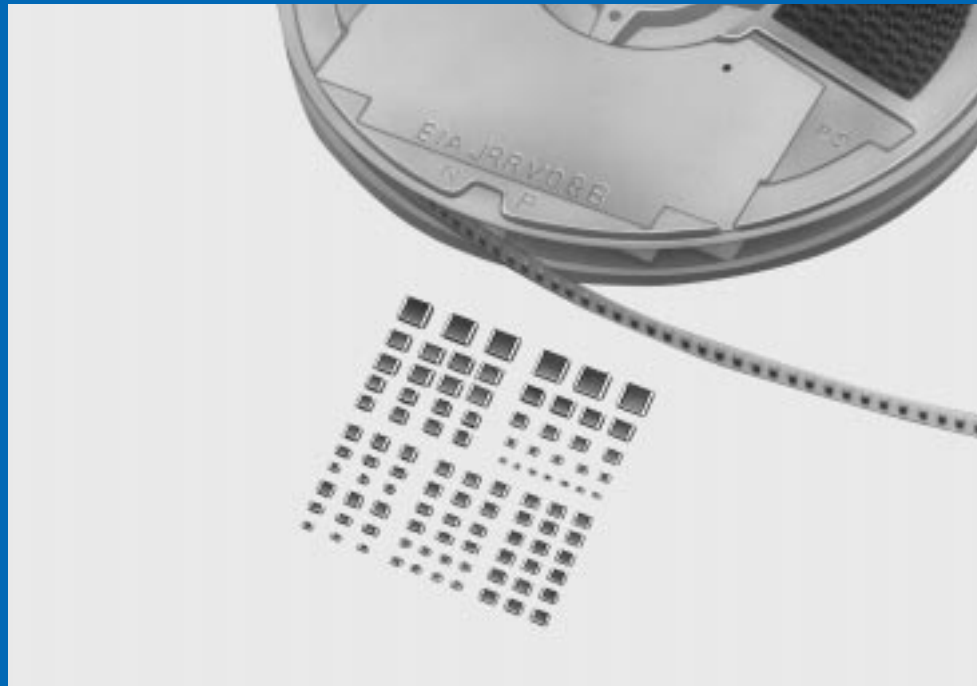

Murata  
Manufacturing Co., Ltd.

[www.DataSheet4U.com](http://www.DataSheet4U.com)

Cat.No.C02E-6

# CONTENTS

Part Numbering	2
1 for Flow/Reflow Soldering GRM Series	3
2 for Reflow Soldering GRM Series	9
3 Ultra-small Type GRM33 Series	12
4 Thin Type for Flow/Reflow GRM Series	14
● GRM Series Specifications and Test Methods	15
5 High-power Type GRM600 Series	20
GRM Series Data	25
6 Low ESL Wide-width Type LL Series	27
7 Monolithic Microchip GM Series	33
8 Capacitor Arrays GNM Series	36
9 for Ultrasonic Sensors ZLM Type	41
10 High-frequency for Flow/Reflow Soldering GRQ Series	44
11 High-Q & High-power GRH/RPN100 Series	49
12 High-frequency GRH/RPN700 Series	55
GRH/RPN Series Data	61
Package	63
Notice	67
Reference Data	76
13 for High-voltage Low Dissipation Type GHM1000 Series	83
14 for High-voltage High-capacitance Type GHM1500 Series	88
15 for High-voltage GHM2000 Series AC250V r.m.s.	91
16 for High-voltage GHM3000 Series Safety Recognized	95
GHM Series Data	99
Package	101
⚠ Caution	104
Notice	107

## Part Numbering

(Please specify the part number when ordering.)

(Ex.) **GRM40** **C0G** **151** **J** **50**   **PT** **GHM3045** **X7R** **101** **K** - **GC**  
 Type ① ② ③ ④ Murata's control no. ⑤ Type ① ② ③ ⑥

### ① Temperature Characteristic

- Temperature compensating type

Code	C0G	C0H	P2H	R2H	S2H	T2H	U2J	SL
Temp. range	-55 to 125°C			-55 to 85°C				
Temp. coeff. (ppm/°C)	0±30	0±60	-150±60	-220±60	-330±60	-470±60	-750±120	+350 to -1000

- High dielectric constant

Code	X7R	X5R	Z5U	Y5V	B	R
Temp. range	-55 to 125°C	-55 to 85°C	10 to 85°C	-30 to 85°C	-25 to 85°C	
Cap. change (%)	±15	±15	+22 -56	+22 -82	±10	±15

- High-Voltage/AC250V type/Safety std. Recognition

Code	SL	R/X7R	B
Temp. range	20 to 85°C	-55 to 125°C	-25 to 85°C
Cap. change	+350 to -1000ppm/°C	±15%	±10%

- For ultrasonic

code	ZLM	
Temp. range	-25 to 20°C	20 to 85°C
Temp. coeff. (ppm/°C)	-4700 +1000 -2500	-4700 +500 -1000

### ② Capacitance

(Ex.)

Code	Capacitance (pF)
<b>0R5</b>	0.5
<b>R75</b>	0.75
<b>010</b>	1
<b>100</b>	10
<b>101</b>	100
<b>103</b>	10000

### ③ Capacitance Tolerance

Type	Temperature Characteristic	Code	Capacitance Tolerance	Capacitance Step
Temperature compensating type	C0G to U2J (NP0) (N750) and SL	<b>C</b>	≤10 pF ±0.25pF	0.5, 1, 1.5, 2, 3, 4, 5 (pF)
		<b>D</b>	±0.5pF	6, 7, 8, 9, 10 (pF)
		<b>J</b>	>10 pF ±5%	E12 series
High dielectric constant	X7R, X5R, B, R Z5U Z5U, Y5V	<b>K</b>	±10%	E6 series
		<b>M</b>	±20%	E6 series
		<b>Z</b>	+80, -20%	E3 series
High-Voltage/AC250V type/ Safety Standard Recognition	SL X7R, B, R B	<b>D</b>	≤10 pF ±0.5pF	10 (pF)
		<b>J</b>	>10 pF ±5%	E12 series
		<b>K</b>	±10%	E6 series
		<b>M</b>	±20%	E3 series

### ④ Rated Voltage

Code	Rated voltage	Code	Rated voltage	Code	Rated voltage
<b>6.3</b>	DC6.3V	<b>50</b>	DC50V	<b>3K</b>	DC3.15kV
<b>10</b>	DC10V	<b>250</b>	DC250V	<b>AC250</b>	AC250V(r.m.s.)
<b>16</b>	DC16V	<b>630</b>	DC630V		
<b>25</b>	DC25V	<b>2K</b>	DC2kV		

Not apply to GHM3000 Series [Rated voltage : AC250V (r.m.s.)]

### ⑤ Packing Code (only for chip type)

Code	Packaging
<b>PB</b>	Bulk packaging in a bag
<b>PT</b>	Tape carrier packaging
<b>PC</b>	Bulk case packaging
<b>PM</b>	Bulk packaging in a tray

### ⑥ Type Designation (Apply to GHM3000 Series.)

Code	Type Designation
<b>-GB</b>	Type GB
<b>-GC</b>	Type GC

# CHIP MONOLITHIC CERAMIC CAPACITOR

1

## for Flow/Reflow Soldering GRM Series

### ■ Features

1. Terminations are made of metal highly resistant to migration.
2. The GRM series is a complete line of chip ceramic capacitors in 10V,16V,25V,50V,100V,200V and 500V ratings. These capacitors have temperature characteristics ranging from COG to Y5V.
3. A wide selection of sizes is available, from the miniature GRM36(LxWxT:1.0x0.5x0.5mm) to GRM42-6 (LxWxT:3.2x1.6x1.25mm).  
GRM39, 40 and GRM42-6 types are suited to flow and reflow soldering.  
GRM36 types is applied to only reflow soldering.
4. Stringent dimensional tolerances allow highly reliable, high speed automatic chip placement on PCBs.
5. The GRM series is available in paper or plastic embossed tape and reel packaging for automatic placement. Bulk case packaging is also available for GRM36,GRM39,GRM40(T:0.6,1.25).

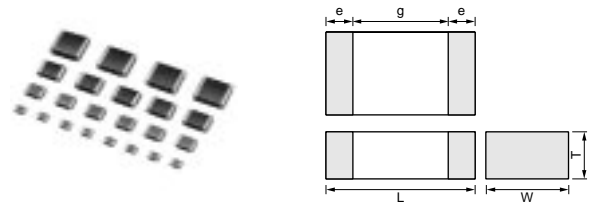

Part Number	Dimensions (mm)				
	L	W	T	e	g min.
GRM36	1.0 ±0.05	0.5 ±0.05	0.5 ±0.05	0.15 to 0.3	0.4
GRM39*	1.6 ±0.1	0.8 ±0.1	0.8 ±0.1	0.2 to 0.5	0.5
GRM40	2.0 ±0.1	1.25 ±0.1	0.6 ±0.1	0.2 to 0.7	0.7
			0.85 ±0.1		
			1.25 ±0.1		
GRM42-6	3.2 ±0.15	1.6 ±0.15	0.85 ±0.1	0.3 to 0.8	1.5
			1.15 ±0.1		
	3.2 ±0.2	1.6 ±0.2	1.6 ±0.2		

\* Bulk Case : 1.6 ±0.07(L)×0.8 ±0.07(W)×0.8 ±0.07(T)

### ■ Application

General electronic equipment.

DataSheet4U.com

## Temperature Compensating Type GRM36 Series

Part Number	GRM36								
L x W(mm)	1.00x0.50								
TC Code	COG	COH	P2H	R2H	S2H	SL		T2H	U2J
Rated Volt.(Vdc)	50	25	50	50	50	25	50	50	50
Capacitance and T(mm)									
0.5pF	0.50								
0.75pF	0.50								
1.0pF	0.50								
2.0pF	0.50								
3.0pF	0.50		0.50	0.50	0.50			0.50	0.50
4.0pF	0.50		0.50	0.50	0.50			0.50	0.50
5.0pF	0.50		0.50	0.50	0.50			0.50	0.50
6.0pF	0.50		0.50	0.50	0.50			0.50	0.50
7.0pF	0.50		0.50	0.50	0.50			0.50	0.50
8.0pF	0.50		0.50	0.50	0.50			0.50	0.50
9.0pF	0.50		0.50	0.50	0.50			0.50	0.50
10.0pF	0.50		0.50	0.50	0.50			0.50	0.50
12.0pF	0.50		0.50	0.50	0.50			0.50	0.50
15.0pF	0.50		0.50	0.50	0.50			0.50	0.50
18.0pF	0.50		0.50	0.50	0.50			0.50	0.50
22.0pF	0.50		0.50	0.50	0.50			0.50	0.50
27.0pF	0.50		0.50	0.50	0.50			0.50	0.50
33.0pF	0.50			0.50	0.50			0.50	0.50
39.0pF	0.50				0.50			0.50	0.50
47pF	0.50						0.50	0.50	0.50
56pF	0.50						0.50	0.50	0.50

Continued on the following page.

DataSheet4U.com

3

 Continued from the preceding page.

Part Number	GRM36								
L x W(mm)	1.00x0.50								
TC Code	COG	C0H	P2H	R2H	S2H	SL		T2H	U2J
Rated Volt.(Vdc)	50	25	50	50	50	25	50	50	50
Capacitance and T(mm)									
68pF	0.50						0.50	0.50	0.50
82pF	0.50						0.50	0.50	0.50
100pF	0.50						0.50	0.50	0.50
120pF	0.50						0.50		0.50
150pF	0.50						0.50		0.50
180pF		0.50					0.50		0.50
220pF		0.50				0.50			
270pF		0.50				0.50			
330pF						0.50			
390pF						0.50			

### Temperature Compensating Type GRM39 Series

Part Number	GRM39												
L x W(mm)	1.60x0.80												
TC Code	COG			C0H	P2H	R2H	S2H	SL				T2H	U2J
Rated Volt.(Vdc)	50	100	200	25	50	50	50	25	50	100	200	50	50
Capacitance and T(mm)													
0.5pF	0.80												
1.0pF	0.80		0.80										
2.0pF	0.80		0.80										
3.0pF	0.80		0.80		0.80	0.80	0.80					0.80	0.80
4.0pF	0.80		0.80		0.80	0.80	0.80					0.80	0.80
5.0pF	0.80		0.80		0.80	0.80	0.80					0.80	0.80
6.0pF	0.80		0.80		0.80	0.80	0.80					0.80	0.80
7.0pF	0.80		0.80		0.80	0.80	0.80					0.80	0.80
8.0pF	0.80		0.80		0.80	0.80	0.80					0.80	0.80
9.0pF	0.80		0.80		0.80	0.80	0.80					0.80	0.80
10.0pF	0.80		0.80		0.80	0.80	0.80					0.80	0.80
12pF	0.80	0.80			0.80	0.80	0.80				0.80	0.80	0.80
15pF	0.80	0.80			0.80	0.80	0.80				0.80	0.80	0.80
18pF	0.80	0.80			0.80	0.80	0.80				0.80	0.80	0.80
22pF	0.80	0.80			0.80	0.80	0.80				0.80	0.80	0.80
27pF	0.80	0.80			0.80	0.80	0.80				0.80	0.80	0.80
33pF	0.80	0.80			0.80	0.80	0.80				0.80	0.80	0.80
39pF	0.80	0.80			0.80	0.80	0.80				0.80	0.80	0.80
47pF	0.80	0.80			0.80	0.80	0.80				0.80	0.80	0.80
56pF	0.80	0.80			0.80	0.80	0.80				0.80	0.80	0.80
68pF	0.80	0.80			0.80	0.80	0.80	0.80			0.80	0.80	0.80
82pF	0.80	0.80			0.80	0.80	0.80	0.80	0.80		0.80	0.80	0.80
100pF	0.80	0.80			0.80	0.80	0.80	0.80	0.80		0.80	0.80	0.80
120pF	0.80	0.80			0.80	0.80	0.80	0.80	0.80	0.80		0.80	0.80
150pF	0.80	0.80			0.80	0.80	0.80	0.80	0.80	0.80		0.80	0.80
180pF	0.80				0.80	0.80	0.80	0.80	0.80	0.80		0.80	0.80
220pF	0.80					0.80	0.80	0.80	0.80	0.80		0.80	0.80
270pF	0.80							0.80	0.80	0.80		0.80	0.80
330pF	0.80							0.80	0.80	0.80		0.80	0.80
390pF	0.80							0.80	0.80	0.80		0.80	0.80
470pF	0.80							0.80					0.80
560pF	0.80			0.80				0.80					0.80
680pF				0.80				0.80					0.80
820pF				0.80				0.80					0.80
1000pF				0.80				0.80					0.80

Continued on the following page. 

 Continued from the preceding page.

Part Number	GRM39												
L x W(mm)	1.60x0.80												
TC Code	COG			C0H	P2H	R2H	S2H	SL				T2H	U2J
Rated Volt.(Vdc)	50	100	200	25	50	50	50	25	50	100	200	50	50
Capacitance and T(mm)													
1200pF								0.80					
1500pF								0.80					

### Temperature Compensating Type GRM40 Series

Part Number	GRM40												
L x W(mm)	2.00x1.25												
TC Code	COG			C0H	P2H	R2H	S2H	SL				T2H	U2J
Rated Volt.(Vdc)	50	100	200	25	50	50	50	25	50	100	200	50	50
Capacitance and T(mm)													
12pF			0.85										
15pF			0.85										
18pF			0.85										
22pF			0.85										
27pF			0.85										
33pF			0.85										
39pF			0.85										
47pF			0.85										
56pF			0.85										
68pF	0.85	1.25											
82pF	0.85	1.25											
100pF	0.85	1.25											
120pF	0.85	1.25									0.85		
150pF	0.85	1.25									1.25		
180pF	0.85	1.25		0.85							1.25		
220pF	0.85	1.25		0.85	0.85						1.25		
270pF	0.85			0.85	0.85	0.85					1.25		
330pF	0.85			0.85	0.85	0.85					1.25		
390pF	1.25			1.25	0.85	0.85					1.25		
470pF	1.25			1.25	0.85	0.85			0.85	1.25			
560pF	0.60	1.25		1.25	1.25	1.25			0.85		1.25		
680pF	0.85	1.25			1.25	1.25			0.85		1.25		
820pF	0.85	1.25				1.25		0.60	1.25		1.25	0.60	
1000pF	0.85	1.25						0.60	1.25		1.25	0.60	
1200pF	0.85							0.60	1.25		1.25	0.60	
1500pF	0.85							0.85	1.25		1.25	0.85	
1800pF	1.25							0.85	1.25		1.25	0.85	
2200pF	1.25							0.85				0.85	
2700pF				1.25				1.25				1.25	
3300pF				1.25				1.25				1.25	
3900pF				1.25				0.85					
4700pF								0.85					
5600pF								1.25					
6800pF								1.25					

1

## Temperature Compensating Type GRM42-6 Series

Part Number	GRM42-6														
L x W(mm)	3.20x1.60														
TC Code	C0G				C0H	P2H	R2H	S2H	SL					T2H	U2J
Rated Volt.(Vdc)	50	100	200	500	25	50	50	50	25	50	100	200	500	50	50
Capacitance and T(mm)															
1.0pF				1.15											
2.0pF				1.15											
3.0pF				1.15											
4.0pF				1.15											
5.0pF				1.15											
6.0pF				1.15											
7.0pF				1.15											
8.0pF				1.15											
9.0pF				1.15											
10.0pF				1.15											
12pF				1.15											
15pF				1.15											
18pF				1.15											
22pF				1.15											
27pF				1.15											
33pF				1.15											
39pF				1.15											
47pF				1.15											
56pF				1.15											
68pF				1.15											
82pF				1.15											
100pF				1.15											
120pF				1.15											
150pF														1.15	
180pF														1.15	
220pF														1.15	
270pF			1.15											1.15	
330pF			1.15												
390pF			1.15												
470pF			1.15												
560pF														1.15	
680pF						0.85								1.15	
820pF						0.85	0.85							1.15	
1000pF						1.15	1.15	0.85						1.15	
1200pF		1.15				1.15	1.15	1.15						1.15	
1500pF		1.15				1.15	1.15	1.15							
1800pF		1.15						1.15							
2200pF		1.15									1.15			1.15	
2700pF	0.85										1.15			1.15	
3300pF	0.85										1.15			1.15	
3900pF	1.15									0.85	1.15			1.15	0.85
4700pF	1.15									0.85	1.15				0.85
5600pF	1.15									0.85					0.85
6800pF					0.85					1.15					1.15
8200pF					1.15					1.15					1.15
10000pF					1.15				1.15						
12000pF									1.15						
15000pF									1.15						

## High Dielectric Constant Type X5R GRM36/40/42-6 Series

TC Code	X5R						
Part Number	GRM36		GRM39	GRM40		GRM42-6	
L x W(mm)	1.00x0.50		1.60x0.80	2.00x1.25		3.20x1.60	
Rated Volt.(Vdc)	10	6.3	6.3	10	6.3	10	16
Capacitance and T(mm)							
33000pF	0.50						
47000pF	0.50						
68000pF	0.50						
0.1μF	0.50						
0.47μF			0.80				
1.0μF			0.80		0.85		
2.20μF				1.25			1.15
3.3μF						1.30	
4.7μF				1.25		1.60	1.60
10.0μF						1.60	

4.7μF for 6.3V is replaced with GRM40-034 series of L:2±0.15, W:1.25±0.15, T:1.25±0.15.

T:1.25±0.1mm is also available for GRM40 10V 1.0μF type.

3.3μF for 10V rated is replaced with GRM42-631series of L:3.2±0.2, W:1.6±0.2, T:1.3+0/-0.3mm.

T:1.15mm is also available for GRM42-6 16V 1.0μF type.

The tolerance will be changed to L:3.2±0.2, W:1.6±0.2, T:1.15±0.15 for GRM42-6 16V 2.2μF type.

## High Dielectric Constant Type X7R GRM36/39/40/42-6 Series

TC Code	X7R																
Part Number	GRM36				GRM39				GRM40				GRM42-6				
L x W(mm)	1.00x0.50				1.60x0.80				2.00x1.25				3.20x1.60				
Rated Volt.(Vdc)	10	16	25	50	10	16	25	50	100	200	16	25	50	10	16	25	50
Capacitance and T(mm)																	
220pF				0.50				0.80		0.80							
330pF				0.50				0.80		0.80							
470pF				0.50				0.80		0.80							
680pF				0.50				0.80		0.80							
1000pF				0.50				0.80		0.80							
1500pF				0.50				0.80		0.80							
2200pF				0.50				0.80	0.80								
3300pF				0.50				0.80	0.80								
4700pF				0.50				0.80									
6800pF			0.50					0.80									
10000pF			0.50					0.80									
15000pF		0.50						0.80									
22000pF		0.50						0.80									
33000pF	0.50							0.80						0.85			
47000pF	0.50							0.80						1.25			
68000pF								0.80									
0.10μF							0.80	0.80				1.25	1.25				
0.15μF						0.80						1.25	1.25				
0.22μF						0.80						0.85	1.25				1.15
0.33μF												1.25					0.85
0.47μF											0.85	1.25					1.15
0.68μF											0.85					0.85	
1.00μF											1.25			0.85	0.85	1.15	
1.5μF															1.15		
2.2μF														1.15	1.15		

0.10μF, 50V rated are GRM40-034 series of L:2±0.15, W:1.25±0.15, T:1.25±0.15.

T:1.25±0.1mm is also available for GRM42-6 1.0μF for 16V.

The tolerance will be changed to L:3.2±0.2, W:1.6±0.2, T:1.15±0.15 for GRM42-6 16V 2.2μF type.



1

## High Dielectric Constant Type Y5V GRM36/39/40/42-6 Series

TC Code	Y5V															
Part Number	GRM36			GRM39					GRM40				GRM42-6			
L x W(mm)	1.00x0.50			1.60x0.80					2.00x1.25				3.20x1.60			
Rated Volt.(Vdc)	16	25	50	10	16	25	50	100	10	16	25	50	6.3	10	16	25
Capacitance and T(mm)																
2200pF			0.50													
4700pF			0.50					0.80								
10000pF			0.50				0.80									
22000pF		0.50					0.80									
47000pF	0.50						0.80									
0.10μF	0.50					0.80						0.85				
0.22μF					0.80						0.85	1.25				
0.47μF				0.80	0.80							1.25				
1.0μF				0.80					0.85	0.85	0.85				0.85	1.15
1.5μF										1.25	1.25					
2.2μF									1.25	1.25	1.25			0.85	1.15	
4.7μF									1.25					1.15	1.15	
10.0μF													1.15	1.15		

T:1.25±0.1mm is also available for GRM40 16V 1.0μF type.

## High Dielectric Constant Type Z5U GRM39/40/42-6 Series

TC Code	Z5U								
Part Number	GRM39			GRM40			GRM42-6		
L x W(mm)	1.60x0.80			2.00x1.25			3.20x1.60		
Rated Volt.(Vdc)	50	100	100	50	100	200	50	100	200
Capacitance and T(mm)									
2200pF	0.80	0.80				1.25			
4700pF	0.80				0.85				1.15
10000pF	0.80				1.25				
22000pF				0.60				0.85	
47000pF				0.60					
0.10μF				0.85					
0.22μF							0.85		

# CHIP MONOLITHIC CERAMIC CAPACITOR

## for Reflow Soldering GRM Series

### ■ Features

1. Terminations are made of metal highly resistant to migration.
2. The GRM series is a complete line of chip ceramic capacitors in 25V,50V,100V,200V and 500V rated. These capacitors have temperature characteristics ranging from C0G to Y5V.
3. This series consists of type GRM42-2(LxWxT:3.2x2.5x0.85mm) to type GRM44-1(LxWxT:5.7x5.0x2.0mm). These are suited to only reflow soldering.
4. Stringent dimensional tolerances allow highly reliable, high speed automatic chip placements on PCBs.
5. The GRM series is available in plastic embossed tape or paper taping and reel packaging for automatic placement.

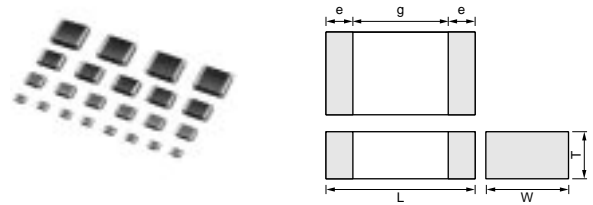

Part Number	Dimensions (mm)				
	L	W	T	e min.	g min.
GRM42-2	3.2 ±0.3	2.5 ±0.2	0.85 ±0.1	0.3	1.0
			1.15 ±0.1		
			1.35 ±0.15		
			1.8 ±0.2		
GRM43-2	4.5 ±0.4	3.2 ±0.3	2.0 max.	0.3	2.0
GRM44-1	5.7 ±0.4	5.0 ±0.4	2.0 max.	0.3	2.0

### ■ Application

General electronic equipment.

### Temperature Compensating Type GRM42-2 Series

Part Number	DataSheet4U GRM42-2							
L x W(mm)	3.20x2.50							
TC Code	C0G				SL			
Rated Volt.(Vdc)	50	100	200	500	50	100	200	500
Capacitance and T(mm)								
150pF				1.35				
180pF				1.35				
330pF								1.15
390pF								1.15
470pF								1.35
560pF			1.35					
680pF			1.35					
820pF			1.35					
1000pF			1.35					
1500pF							1.35	
2700pF		1.35						
3300pF		1.35						
3900pF		1.35						
5600pF						1.35		
6800pF	1.35					1.35		
10000pF					1.35			
12000pF					1.35			

## Temperature Compensating Type GRM43-2 Series

Part Number	GRM43-2							
L x W(mm)	4.50x3.20							
TC Code	COG				SL			
Rated Volt.(Vdc)	50	100	200	500	50	100	200	500
Capacitance and T(mm)								
220pF				2.00				
270pF				2.00				
330pF				2.00				
390pF				2.00				
470pF				2.00				
560pF								2.00
680pF								2.00
820pF								2.00
1000pF								2.00
1200pF			2.00					2.00
1500pF			2.00					
1800pF			2.00				2.00	
2200pF			2.00				2.00	
2700pF			2.00				2.00	
3300pF							2.00	
3900pF							2.00	
4700pF		2.00						
5600pF		2.00						
6800pF		2.00						
8200pF	2.00	2.00				2.00		
10000pF	2.00	2.00				2.00		
12000pF	2.00	2.00				2.00		
15000pF					2.00	2.00		

## Temperature Compensating Type GRM44-1 Series

Part Number	GRM44-1							
L x W(mm)	5.70x5.00							
TC Code	COG				SL			
Rated Volt.(Vdc)	50	100	200	500	50	100	200	
Capacitance and T(mm)								
560pF				2.00				
680pF				2.00				
820pF				2.00				
1000pF				2.00				
3300pF			2.00					
3900pF			2.00					
4700pF			2.00					2.00
5600pF			2.00					2.00
6800pF								2.00
8200pF								2.00
15000pF	2.00	2.00						
18000pF	2.00	2.00				2.00	2.00	
22000pF	2.00	2.00				2.00	2.00	
27000pF	2.00	2.00				2.00	2.00	
33000pF	2.00					2.00	2.00	
39000pF	2.00					2.00	2.00	

### High Dielectric Constant Type GRM42-2 Series

Part Number	GRM42-2										
L x W(mm)	3.20x2.50										
TC Code	X5R	X7R					Y5V	Z5U			
Rated Volt.(Vdc)	10	16	25	50	100	200	50	50	100	200	
Capacitance and T(mm)											
10000pF										1.15	
15000pF										1.35	
22000pF										1.35	
33000pF						1.35					
47000pF						1.35			1.35		
68000pF					1.35				1.35		
0.10μF					1.35				1.35		
0.33μF								1.15			
0.47μF				1.15							
0.68μF				1.35							
1.00μF				1.80			1.8	1.80			
2.2μF		1.15	1.80								
3.3μF		1.35									
4.7μF		1.80									
10.0μF	2.50										

### High Dielectric Constant Type GRM43-2 Series

Part Number	GRM43-2						
L x W(mm)	4.50x3.20						
TC Code	X7R			Z5U			
Rated Volt.(Vdc)	50	100	200	50	100	200	
Capacitance and T(mm)							
33000pF							2.00
47000pF							2.00
68000pF			2.00				2.00
100000pF			2.00				2.00
0.15μF		2.00				2.00	
0.22μF		2.00				2.00	
0.33μF	2.00						
0.47μF	2.00				1.50		
0.68μF					1.50		
1.0μF					2.00		

### High Dielectric Constant Type GRM44-1 Series

Part Number	GRM44-1						
L x W(mm)	5.70x5.00						
TC Code	X7R			Z5U			
Rated Volt.(Vdc)	50	100	200	50	100	200	
Capacitance and T(mm)							
0.15μF			2.00				2.00
0.22μF			2.00				2.00
0.33μF		2.00				2.00	
0.47μF		2.00				2.00	
0.68μF	2.00					2.00	
1.0μF	2.00						
1.5μF	2.00				2.00		

# CHIP MONOLITHIC CERAMIC CAPACITOR

## Ultra-small Type GRM33 Series

### ■ Features

1. Small chip size (LXWXT : 0.6X0.3X0.3mm ).
2. Terminations are made of metal highly resistant to migration.
3. GRM33 type is suited to only reflow soldering.
4. Stringent dimensional tolerances are allow highly reliable, high speed autom atic chip placements on PCBs.
5. GRM33 series are suited to miniature micro wave module, portable equipment and high-frequency circuit.

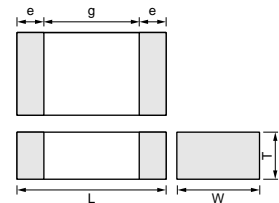

Part Number	Dimensions (mm)				
	L	W	T	e	g min.
<b>GRM33</b>	0.6 ±0.03	0.3 ±0.03	0.3 ±0.03	0.1 to 0.2	0.2

### ■ Application

- Miniature micro wave module.
- Portable equipment.
- High-frequency circuit.

Part Number	<b>GRM33</b>				
L x W(mm)	0.6x0.3				
TC Code	COG	X7R	Y5V		
Rated Volt.(Vdc)	25	16	10		
Capacitance and T(mm)					
0.5pF	0.3				
1pF	0.3				
2pF	0.3				
3pF	0.3				
4pF	0.3				
5pF	0.3				
6pF	0.3				
7pF	0.3				
8pF	0.3				
9pF	0.3				
10pF	0.3				
12pF	0.3				
15pF	0.3				
18pF	0.3				
22pF	0.3				
27pF	0.3				
33pF	0.3				
39pF	0.3				
47pF	0.3				
56pF	0.3				
68pF	0.3				
82pF	0.3				
100pF	0.3		0.3		
150pF			0.3		
220pF			0.3		
330pF			0.3		
470pF			0.3		
680pF			0.3		
1000pF			0.3		
2200pF					0.3

Continued on the following page.

 Continued from the preceding page.

<b>Part Number</b>	<b>GRM33</b>		
<b>L x W(mm)</b>	0.6x0.3		
<b>TC Code</b>	C0G	X7R	Y5V
<b>Rated Volt.(Vdc)</b>	25	16	10
<b>Capacitance and T(mm)</b>			
4700pF			0.3
10000pF			0.3

DataSheet4U.com

et4U.com

DataShee

# CHIP MONOLITHIC CERAMIC CAPACITOR

## Thin Type for Flow/Reflow GRM Series

### ■ Features

1. This series is suited to flow and reflow soldering. Capacitor terminations are made of metal highly resistant to migration.
2. Large capacitance values enable excellent bypass effects to be realized.
3. Its thin package makes this series ideally suited for the production of small electronic products and for mounting underneath ICs.

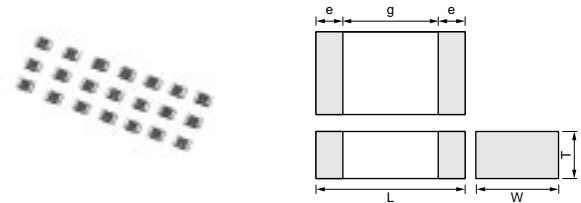

Part Number	Dimensions (mm)				
	L	W	T	e	g min.
<b>GRM36-019</b>	1.0 ±0.05	0.5 ±0.05	0.25 ±0.05	0.15 to 0.3	0.4

### ■ Application

Thin equipment such as IC cards.

Part Number	<b>GRM36-019</b>	
L x W(mm)	1.00x0.50	
TC Code	C0G	
Rated Volt.(Vdc)	25	50
Capacitance and T(mm)		
1pF		0.25
2pF		0.25
3pF		0.25
4pF		0.25
5pF		0.25
6pF		0.25
7pF		0.25
8pF		0.25
9pF		0.25
10pF		0.25
12pF		0.25
15pF		0.25
18pF		0.25
22pF		0.25
27pF		0.25
33pF		0.25
39pF		0.25
47pF		0.25
56pF		0.25
68pF		0.25
82pF		0.25
100pF		0.25
120pF	0.25	
150pF	0.25	
180pF	0.25	
220pF	0.25	

## GRM Series Specifications and Test Methods

No.	Item	Specification		Test Method																								
		Temperature Compensating Type	High Dielectric Type																									
1	Operating Temperature	-55 to +125°C	X5R : -55 to +85°C X7R : -55 to +125°C Z5U : +10 to +85°C Y5V : -30 to +85°C																									
2	Rated Voltage	See the previous page.		The rated voltage is defined as the maximum voltage which may be applied continuously to the capacitor. When AC voltage is superimposed on DC voltage, $V^{P-P}$ or $V^{O-P}$ , whichever is larger, shall be maintained within the rated voltage range.																								
3	Appearance	No defects or abnormalities.		Visual inspection.																								
4	Dimensions	Within the specified dimensions.		Using calipers on micrometer.																								
5	Dielectric Strength	No defects or abnormalities.		No failure shall be observed when *300% of the rated voltage (C0Δ to U2J and SL) or *250% of the rated voltage (X5R, X7R, Z5U and Y5V) is applied between the terminations for 1 to 5 seconds, provided the charge/discharge current is less than 50mA. *200% for 500V																								
6	Insulation Resistance	More than 10,000MΩ or 500Ω • F (Whichever is smaller)		The insulation resistance shall be measured with a DC voltage not exceeding the rated voltage at 25°C and 75%RH max. and within 2 minutes of charging.																								
7	Capacitance	Within the specified tolerance.		The capacitance/Q/D.F. shall be measured at 25°C at the frequency and voltage shown in the table.																								
8	Q/ Dissipation Factor (D.F.)	30pFmin. : Q≥1000 30pFmax. : Q≥400+20C C : Nominal Capacitance (pF)	[X5R,X7R] W.V. : 25Vmin. : 0.025max. W.V. : 16/10V : 0.035max. W.V. : 6.3V 0.05max.(C<3.3μF) 0.1max.(C≥3.3μF)	<table border="1"> <thead> <tr> <th>Item</th> <th>Char.</th> <th>Frequency</th> <th>Voltage</th> </tr> </thead> <tbody> <tr> <td>C0Δ to U2J,SL (1000pF and below)</td> <td></td> <td>1±0.1MHz</td> <td>0.5 to 5Vrms</td> </tr> <tr> <td>C0Δ to U2J,SL (more than 1000pF)</td> <td></td> <td>1±0.1kHz</td> <td>1±0.2Vrms</td> </tr> <tr> <td>X5R,X7R,Y5V (10μF and below)</td> <td></td> <td>1±0.1kHz</td> <td>1±0.2Vrms</td> </tr> <tr> <td>X5R,X7R,Y5V (more than 10μF)</td> <td></td> <td>120±24Hz</td> <td>0.5±0.1Vrms</td> </tr> <tr> <td>Z5U</td> <td></td> <td>1±0.1kHz</td> <td>0.5±0.05Vrms</td> </tr> </tbody> </table>	Item	Char.	Frequency	Voltage	C0Δ to U2J,SL (1000pF and below)		1±0.1MHz	0.5 to 5Vrms	C0Δ to U2J,SL (more than 1000pF)		1±0.1kHz	1±0.2Vrms	X5R,X7R,Y5V (10μF and below)		1±0.1kHz	1±0.2Vrms	X5R,X7R,Y5V (more than 10μF)		120±24Hz	0.5±0.1Vrms	Z5U		1±0.1kHz	0.5±0.05Vrms
			Item		Char.	Frequency	Voltage																					
C0Δ to U2J,SL (1000pF and below)		1±0.1MHz	0.5 to 5Vrms																									
C0Δ to U2J,SL (more than 1000pF)		1±0.1kHz	1±0.2Vrms																									
X5R,X7R,Y5V (10μF and below)		1±0.1kHz	1±0.2Vrms																									
X5R,X7R,Y5V (more than 10μF)		120±24Hz	0.5±0.1Vrms																									
Z5U		1±0.1kHz	0.5±0.05Vrms																									
[Z5U] W.V. : 25Vmin. : 0.025max.	[Y5V] W.V. : 25Vmin. : 0.05max.(C<10μF) : 0.09max.(C≥1.0μF)																											
	W.V. : 16V : 0.07max.(C<1.0μF) : 0.09max.(C≥1.0μF)	W.V. : 10Vmax. : 0.125max.																										
9	Capacitance Change	Within the specified tolerance. (Table A)	X5R : Within±15% (-55 to +85°C) X7R : Within±15% (-55 to +125°C) Z5U : Within +22/-56% (+10 to +85°C) Y5V : Within +22/-82% (-30 to +85°C)	<p>The capacitance change shall be measured after 5 Min. at each specified temperature stage.</p> <p>(1) Temperature Compensating Type</p> <p>The temperature coefficient is determined using the Capacitance measured in step 3 as a reference.</p> <p>When cycling the temperature sequentially from step 1 through 5 (C0Δ : +25°C to +125°C : other temp. coeffs. : +25°C to +85°C) the capacitance shall be within the specified tolerance for the temperature coefficient and capacitance change as Table A.</p> <p>The capacitance drift is calculated by dividing the differences between the maximum and minimum measured values in the step 1,3 and 5 by the cap value in step 3.</p> <table border="1"> <thead> <tr> <th>Step</th> <th>Temperature(°C)</th> </tr> </thead> <tbody> <tr> <td>1</td> <td>25±2</td> </tr> <tr> <td>2</td> <td>-55±3 (for CΔ to U2J/SL/X5R/X7R) -30±3 (for Y5V) 10±3 (for Z5U)</td> </tr> <tr> <td>3</td> <td>25±2</td> </tr> <tr> <td>4</td> <td>125±3 (for CΔ/X7R) 85±3 (for other TC)</td> </tr> <tr> <td>5</td> <td>25±2</td> </tr> </tbody> </table> <p>(2) High Dielectric Constant Type</p> <p>The ranges of capacitance change compared with the above 25°C value over the temperature ranges shown in the table shall be within the specified ranges.</p>	Step	Temperature(°C)	1	25±2	2	-55±3 (for CΔ to U2J/SL/X5R/X7R) -30±3 (for Y5V) 10±3 (for Z5U)	3	25±2	4	125±3 (for CΔ/X7R) 85±3 (for other TC)	5	25±2												
		Step	Temperature(°C)																									
	1	25±2																										
2	-55±3 (for CΔ to U2J/SL/X5R/X7R) -30±3 (for Y5V) 10±3 (for Z5U)																											
3	25±2																											
4	125±3 (for CΔ/X7R) 85±3 (for other TC)																											
5	25±2																											
Temperature Coefficient	Within the specified tolerance. (Table A)	—																										
Capacitance Drift	Within ±0.2% or ±0.05pF (Whichever is larger.) *Not apply to SL/25V	—																										

Continued on the following page. 



# GRM Series Specifications and Test Methods

Continued from the preceding page.

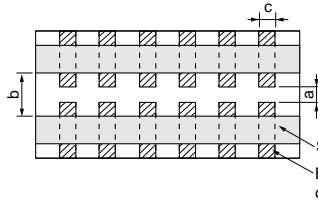
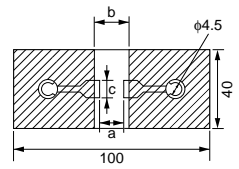
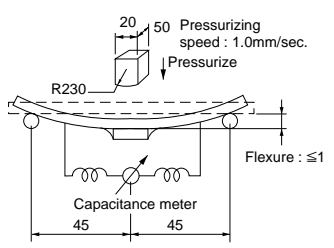
No.	Item	Specification		Test Method																																				
		Temperature Compensating Type	High Dielectric Type																																					
10	Adhesive Strength of Termination	No removal of the terminations or other defect shall occur.		<p>Solder the capacitor to the test jig (glass epoxy board) shown in Fig.1 using a eutectic solder. Then apply 10N* force in parallel with the test jig for 10±1sec. The soldering shall be done either with an iron or using the reflow method and shall be conducted with care so that the soldering is uniform and free of defects such as heat shock. *2N (GRM33) 5N (GRM36,GRM39)</p>  <table border="1" data-bbox="938 683 1452 907"> <thead> <tr> <th>Type</th> <th>a</th> <th>b</th> <th>c</th> </tr> </thead> <tbody> <tr><td>GRM33</td><td>0.3</td><td>0.9</td><td>0.3</td></tr> <tr><td>GRM36</td><td>0.4</td><td>1.5</td><td>0.5</td></tr> <tr><td>GRM39</td><td>1.0</td><td>3.0</td><td>1.2</td></tr> <tr><td>GRM40</td><td>1.2</td><td>4.0</td><td>1.65</td></tr> <tr><td>GRM42-6</td><td>2.2</td><td>5.0</td><td>2.0</td></tr> <tr><td>GRM42-2</td><td>2.2</td><td>5.0</td><td>2.9</td></tr> <tr><td>GRM43-2</td><td>3.5</td><td>7.0</td><td>3.7</td></tr> <tr><td>GRM44-1</td><td>4.5</td><td>8.0</td><td>5.6</td></tr> </tbody> </table> <p style="text-align: right;">(in mm)</p>	Type	a	b	c	GRM33	0.3	0.9	0.3	GRM36	0.4	1.5	0.5	GRM39	1.0	3.0	1.2	GRM40	1.2	4.0	1.65	GRM42-6	2.2	5.0	2.0	GRM42-2	2.2	5.0	2.9	GRM43-2	3.5	7.0	3.7	GRM44-1	4.5	8.0	5.6
		Type	a		b	c																																		
GRM33	0.3	0.9	0.3																																					
GRM36	0.4	1.5	0.5																																					
GRM39	1.0	3.0	1.2																																					
GRM40	1.2	4.0	1.65																																					
GRM42-6	2.2	5.0	2.0																																					
GRM42-2	2.2	5.0	2.9																																					
GRM43-2	3.5	7.0	3.7																																					
GRM44-1	4.5	8.0	5.6																																					
Fig.1																																								
11	Appearance	No defects or abnormalities.		<p>Solder the capacitor to the test jig (glass epoxy board) in the same manner and under the same conditions as (10). The capacitor shall be subjected to a simple harmonic motion having a total amplitude of 1.5mm, the frequency being varied uniformly between the approximate limits of 10 and 55Hz. The frequency range, from 10 to 55Hz and return to 10Hz, shall be traversed in approximately 1 minute. This motion shall be applied for a period of 2 hours in each 3 mutually perpendicular directions (total of 6 hours).</p>																																				
	Capacitance	Within the specified tolerance.																																						
11	Vibration Resistance	Q/D.F.	<p>30pFmin. : <math>Q \geq 1000</math>                      30pFmax. : <math>Q \geq 400+20C</math>                      C : Nominal Capacitance (pF)</p>	<p>[X5R,X7R]                      W.V. : 25Vmin. : 0.025max.                      W.V. : 16/10V : 0.035max.                      W.V. : 6.3V : 0.05max. (C&lt;3.3μF)                      0.1max. (C≥3.3μF)</p> <p>[Z5U]                      W.V. : 25Vmin. : 0.025max.</p> <p>[Y5V]                      W.V. : 25Vmin. : 0.05max. (C&lt;1.0μF)                      : 0.09max. (C≥1.0μF)</p> <p>W.V. : 16V : 0.07max. (C&lt;1.0μF)                      : 0.09max. (C≥1.0μF)</p> <p>W.V. : 10Vmax.:0.125max.</p>																																				
			No crack or marked defect shall occur.																																					
12	Deflection	 <table border="1" data-bbox="367 1814 885 2049"> <thead> <tr> <th>Type</th> <th>a</th> <th>b</th> <th>c</th> </tr> </thead> <tbody> <tr><td>GRM33</td><td>0.3</td><td>0.9</td><td>0.3</td></tr> <tr><td>GRM36</td><td>0.4</td><td>1.5</td><td>0.5</td></tr> <tr><td>GRM39</td><td>1.0</td><td>3.0</td><td>1.2</td></tr> <tr><td>GRM40</td><td>1.2</td><td>4.0</td><td>1.65</td></tr> <tr><td>GRM42-6</td><td>2.2</td><td>5.0</td><td>2.0</td></tr> <tr><td>GRM42-2</td><td>2.2</td><td>5.0</td><td>2.9</td></tr> <tr><td>GRM43-2</td><td>3.5</td><td>7.0</td><td>3.7</td></tr> <tr><td>GRM44-1</td><td>4.5</td><td>8.0</td><td>5.6</td></tr> </tbody> </table> <p style="text-align: center;">t : 1.6mm (GRM33/36 : 0.8mm)</p> <p style="text-align: right;">(in mm)</p>		Type	a	b	c	GRM33	0.3	0.9	0.3	GRM36	0.4	1.5	0.5	GRM39	1.0	3.0	1.2	GRM40	1.2	4.0	1.65	GRM42-6	2.2	5.0	2.0	GRM42-2	2.2	5.0	2.9	GRM43-2	3.5	7.0	3.7	GRM44-1	4.5	8.0	5.6	<p>Solder the capacitor on the test jig (glass epoxy board) shown in Fig.2 using a eutectic solder. Then apply a force in the direction shown in Fig. 3. The soldering shall be done either with an iron or using the reflow method and shall be conducted with care so that the soldering is uniform and free of defects such as heat shock.</p>  <p style="text-align: center;">Fig.3</p>
		Type	a	b	c																																			
GRM33	0.3	0.9	0.3																																					
GRM36	0.4	1.5	0.5																																					
GRM39	1.0	3.0	1.2																																					
GRM40	1.2	4.0	1.65																																					
GRM42-6	2.2	5.0	2.0																																					
GRM42-2	2.2	5.0	2.9																																					
GRM43-2	3.5	7.0	3.7																																					
GRM44-1	4.5	8.0	5.6																																					
Fig.2																																								

Continued on the following page. ↗

## GRM Series Specifications and Test Methods

Continued from the preceding page.

No.	Item	Specification		Test Method															
		Temperature Compensating Type	High Dielectric Type																
13	Solderability of Termination	75% of the terminations is to be soldered evenly and continuously.		Immerse the capacitor in a solution of ethanol (JIS-K-8101) and rosin (JIS-K-5902) (25% rosin in weight proportion). Preheat at 80 to 120°C for 10 to 30 seconds. After preheating, immerse in eutectic solder solution for 2±0.5 seconds at 230±5°C.															
14	Resistance to Soldering Heat	The measured and observed characteristics shall satisfy the specifications in the following table.		<p>Preheat the capacitor at 120 to 150°C for 1 minute.</p> <p>Immerse the capacitor in a eutectic solder solution at 270±5°C for 10±0.5 seconds. Let sit at room temperature for 24±2 hours (temperature compensating type) or 48±4 hours (high dielectric constant type), then measure.</p> <p>•Initial measurement for high dielectric constant type Perform a heat treatment at 150 ±18°C for one hour and then let sit for 48±4 hours at room temperature. Perform the initial measurement.</p> <p>*Preheating for GRM42-2/43-2/44-1</p> <table border="1"> <thead> <tr> <th>Step</th> <th>Temperature</th> <th>Time</th> </tr> </thead> <tbody> <tr> <td>1</td> <td>100°C to 120°C</td> <td>1 min.</td> </tr> <tr> <td>2</td> <td>170°C to 200°C</td> <td>1 min.</td> </tr> </tbody> </table>	Step	Temperature	Time	1	100°C to 120°C	1 min.	2	170°C to 200°C	1 min.						
		Step	Temperature		Time														
		1	100°C to 120°C		1 min.														
		2	170°C to 200°C		1 min.														
		Appearance	No marking defects.																
		Capacitance Change	Within ±2.5% or ±0.25pF (Whichever is larger)		X5R,X7R : Within ±7.5% Z5U,Y5V : Within ±20%														
Q/D.F.	30pFmin. : Q≥1000 30pFmax. : Q≥400+20C C : Nominal Capacitance (pF)	[X5R,X7R] W.V. : 25Vmin. : 0.025max. W.V. : 16/10V : 0.035max. W.V. : 6.3V : 0.05max. (C<3.3μF) 0.1max. (C≥3.3μF) [Z5U] W.V. : 25Vmin. : 0.025max. [Y5V] W.V. : 25Vmin. : 0.05max. (C<1.0μF) : 0.09max. (C≥1.0μF) W.V.:16V : 0.07max. (C<1.0μF) : 0.09max. (C≥1.0μF) W.V. : 10Vmax. : 0.125max.																	
I.R.	More than 10,000MΩ or 500Ω • F (Whichever is smaller)																		
Dielectric Strength	No failure																		
15	Temperature Cycle	The measured and observed characteristics shall satisfy the specifications in the following table.		<p>Fix the capacitor to the supporting jig in the same manner and under the same conditions as (10). Perform the five cycles according to the four heat treatments listed in the following table. Let sit for 24±2 hours (temperature compensating type) or 48±4 hour (high dielectric constant type) at room temperature, then measure.</p> <table border="1"> <thead> <tr> <th>Step</th> <th>1</th> <th>2</th> <th>3</th> <th>4</th> </tr> </thead> <tbody> <tr> <td>Temp.(°C)</td> <td>Min. Operating Temp.+0/-3</td> <td>Room Temp.</td> <td>Max. Operating Temp.+3/-0</td> <td>Room Temp.</td> </tr> <tr> <td>Time(min.)</td> <td>30±3</td> <td>2 to 3</td> <td>30±3</td> <td>2 to 3</td> </tr> </tbody> </table> <p>•Initial measurement for high dielectric constant type Perform a heat treatment at 150 ±18°C for one hour and then let sit for 48±4 hours at room temperature. Perform the initial measurement.</p>	Step	1	2	3	4	Temp.(°C)	Min. Operating Temp.+0/-3	Room Temp.	Max. Operating Temp.+3/-0	Room Temp.	Time(min.)	30±3	2 to 3	30±3	2 to 3
		Step	1		2	3	4												
		Temp.(°C)	Min. Operating Temp.+0/-3		Room Temp.	Max. Operating Temp.+3/-0	Room Temp.												
		Time(min.)	30±3		2 to 3	30±3	2 to 3												
		Appearance	No marking defects.																
		Capacitance Change	Within ±2.5% or ±0.25pF (Whichever is larger)		X5R,X7R : Within ±7.5% Z5U,Y5V : Within ±20%														
Q/D.F.	30pFmin. : Q≥1000 30pFmax. : Q≥400+20C C : Nominal Capacitance (pF)	[X5R,X7R] W.V. : 25Vmin. : 0.025max. W.V. : 16/10V : 0.035max. W.V. : 6.3V 0.05max. (C<3.3μF) 0.1max. (C≥3.3μF) [Z5U] W.V. : 2.5Vmin. : 0.025max. [Y5V] W.V. : 25Vmin. : 0.05max. (C<1.0μF) : 0.09max. (C≥1.0μF) W.V. : 16V : 0.07max. (C<1.0μF) : 0.09max. (C≥1.0μF) W.V. : 10Vmax. : 0.125max.																	
I.R.	More than 10,000MΩ or 500Ω • F (Whichever is smaller)																		
Dielectric Strength	No failure																		

Continued on the following page. 

## GRM Series Specifications and Test Methods

 Continued from the preceding page.

No.	Item	Specification		Test Method	
		Temperature Compensating Type	High Dielectric Type		
16	Humidity Steady State	The measured and observed characteristics shall satisfy the specifications in the following table.		Sit the capacitor at 40±2°C and 90 to 95% humidity for 500±12 hours. Remove and let sit for 24±2 hours (temperature compensating type) or 48±4 hours (high dielectric constant type) at room temperature, then measure.	
		Appearance	No marking defects.		
		Capacitance Change	Within ±5% or ±0.5pF (Whichever is larger)		X5R,X7R : Within ±12.5% Z5U,Y5V : Within ±30%
		Q/D.F.	30pF and over : Q≥350 10pF and over 30pF and below : Q≥275+5C/2 10pF and below : Q≥200+10C C : Nominal Capacitance (pF)		[X5R,X7R] W.V. : 25Vmin. : 0.05max. W.V. : 16/10V : 0.05max. W.V. : 6.3V 0.075max. (C<3.3μF) 0.125max. (C≥3.3μF) [Z5U] W.V. : 25Vmin. : 0.05max. [Y5V] W.V. : 25Vmin. : 0.075max. (C<1.0μF) : 0.0125max.(C≥1.0μF) W.V. : 16V : 0.1max. (C<1.0μF) : 0.125max. (C≥1.0μF) W.V. : 10Vmax. : 0.15max.
		I.R.	More than 1,000MΩ or 50Ω • F(Whichever is smaller)		
		Dielectric Strength	No failure		
17	Humidity Load	The measured and observed characteristics shall satisfy the specifications in the following table.		Apply the rated voltage at 40±2°C and 90 to 95% humidity for 500±12 hours. Remove and let sit for 24±2 hours (temperature compensating type) or 48±4 hours (high dielectric constant type) at room temperature, then measure. The charge/discharge current is less than 50mA.  •Initial measurement for Y5V/10Vmax. Apply the rated DC voltage for 1 hour at 40±2°C. Remove and let sit for 48±4 hours at room temperature. Perform initial measurement.	
		Appearance	No marking defects.		
		Capacitance Change	Within ±7.5% or ±0.75pF (Whichever is larger)		X5R,X7R : Within ±12.5% Z5U : Within ±30% Y5V : Within ±30% [W.V. : 10Vmax.] Y5V : Within +30/-40%
		Q/D.F.	30pF and over : Q≥200 30pF and below : Q≥100±10C/3 C : Nominal Capacitance (pF)		[X5R,X7R] W.V. : 25Vmin. : 0.05max. W.V. : 16/10V : 0.05max. W.V. : 6.3V 0.075max. (C<3.3μF) 0.125max. (C≥3.3μF) [Z5U] W.V. : 25Vmin. : 0.05max. [Y5V] W.V. : 25Vmin. : 0.075max. (C<1.0μF) : 0.0125max. (C≥1.0μF) W.V. : 16V : 0.1max. (C<1.0μF) : 0.125max. (C≥1.0μF) W.V. : 10Vmax. : 0.15max.
		I.R.	More than 500MΩ or 25Ω • F(Whichever is smaller)		
		Dielectric Strength	No failure		

Continued on the following page. 

## GRM Series Specifications and Test Methods

No.	Item	Specification		Test Method
		Temperature Compensating Type	High Dielectric Type	
18		The measured and observed characteristics shall satisfy the specifications in the following table.		Apply 200% of the rated voltage for 1000±12 hours at the maximum operating temperature ±3°C. Let sit for 24±2 hours (temperature compensating type) or 48±4 hours (high dielectric constant type) at room temperature, then measure. The charge/discharge current is less than 50mA. •Initial measurement for high dielectric constant type. Apply 200% of the rated DC voltage for one hour at the maximum operating temperature ±3°C. Remove and let sit for 48±4 hours at room temperature. Perform initial measurement.  *150% for 500V and C≥10μF
	Appearance	No marking defects.		
	Capacitance Change	Within ±3% or ±0.3pF (Whichever is larger)	X5R,X7R : Within ±12.5% Z5U : Within ±30% Y5V : Within ±30% (Cap<1.0μF) Y5V : Within +30/−40%(Cap≥1.0μF)	
	Q/D.F.	30pF and over : Q≥350 10pF and over : Q≥275±5C/2 30pF and below : Q≥200±10C C : Nominal Capacitance (pF)	[X5R,X7R] W.V. : 25Vmin. : 0.05max. W.V. : 16/10V : 0.05max. W.V. : 6.3V : 0.075max. (C<3.3μF) 0.125max. (C≥3.3μF) [Z5U] W.V. : 25Vmin. : 0.05max. [Y5V] W.V. : 25Vmin. : 0.075max. (C<1.0μF) : 0.0125max. (C≥1.0μF) W.V. : 16V : 0.1max. (C<1.0μF) : 0.125max. (C≥1.0μF) W.V. : 10Vmax. : 0.15max.	
	I.R.	More than 1,000MΩ or 50Ω•F(Whichever is smaller)		
	Dielectric Strength	No failure		
19	Notice	When mounting capacitor of 500V rated voltage, perform the epoxy resin coating(min.1.0mm thickness)		

Table A

Char.	Nominal Values (ppm/°C)*	Capacitance Change from 25°C (%)					
		−55		−30		−10	
		Max.	Min.	Max.	Min.	Max.	Min.
C0G	0± 30	0.58	−0.24	0.40	−0.17	0.25	−0.11
C0H	0± 60	0.87	−0.48	0.59	−0.33	0.38	−0.21
P2H	−150± 60	2.33	0.72	1.61	0.50	1.02	0.32
R2H	−220± 60	3.02	1.28	2.08	0.88	1.32	0.56
S2H	−330± 60	4.09	2.16	2.81	1.49	1.79	0.95
T2H	−470± 60	5.46	3.28	3.75	2.26	2.39	1.44
U2J	−750±120	8.78	5.04	6.04	3.47	3.84	2.21
SL	+350 to −1000	—	—	—	—	—	—

\*Nominal values denote the temperature coefficient within a range of 25°C to 125°C (for CoΔ)/85°C (for other TC).

# CHIP MONOLITHIC CERAMIC CAPACITOR

## High-power Type GRM600 Series

### ■ Features

1. Mobile Telecommunication and RF module, mainly.
2. Quality improvement of telephone call, Low power Consumption, yield ratio improvement.

### ■ Application

VCO, PA, Mobile Telecommunication

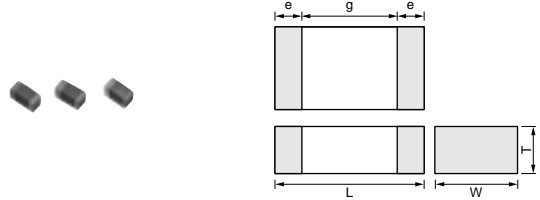

Part Number	Dimensions (mm)				
	L	W	T	e	g min.
<b>GRM615</b>	1.0 ±0.05	0.5 ±0.05	0.5 ±0.05	0.15 to 0.3	0.4

5

Part Number	Rated Voltage (Vdc)	TC Code	Capacitance (pF)	Length L (mm)	Width W (mm)	Thickness T (mm)
GRM615C0G010B50	50	C0G	1.0 -0.1pF	1.00	0.50	0.50
GRM615C0G010C50	50	C0G	1.0 -0.25pF	1.00	0.50	0.50
GRM615C0G020B50	50	C0G	2.0 -0.1pF	1.00	0.50	0.50
GRM615C0G020C50	50	C0G	2.0 -0.25pF	1.00	0.50	0.50
GRM615C0G030B50	50	C0G	3.0 -0.1pF	1.00	0.50	0.50
GRM615C0G030C50	50	C0G	3.0 -0.25pF	1.00	0.50	0.50
GRM615C0G040B50	50	C0G	4.0 -0.1pF	1.00	0.50	0.50
GRM615C0G040C50	50	C0G	4.0 -0.25pF	1.00	0.50	0.50
GRM615C0G050B50	50	C0G	5.0 -0.1pF	1.00	0.50	0.50
GRM615C0G050C50	50	C0G	5.0 -0.25pF	1.00	0.50	0.50
GRM615C0G060C50	50	C0G	6.0 -0.25pF	1.00	0.50	0.50
GRM615C0G060D50	50	C0G	6.0 -0.5pF	1.00	0.50	0.50
GRM615C0G070C50	50	C0G	7.0 -0.25pF	1.00	0.50	0.50
GRM615C0G070D50	50	C0G	7.0 -0.5pF	1.00	0.50	0.50
GRM615C0G080C50	50	C0G	8.0 -0.25pF	1.00	0.50	0.50
GRM615C0G080D50	50	C0G	8.0 -0.5pF	1.00	0.50	0.50
GRM615C0G090C50	50	C0G	9.0 -0.25pF	1.00	0.50	0.50
GRM615C0G090D50	50	C0G	9.0 -0.5pF	1.00	0.50	0.50
GRM615C0G0R5B50	50	C0G	0.5 -0.1pF	1.00	0.50	0.50
GRM615C0G0R5C50	50	C0G	0.50 -0.25pF	1.00	0.50	0.50
GRM615C0G100C50	50	C0G	10 -0.25pF	1.00	0.50	0.50
GRM615C0G100D50	50	C0G	10.0 -0.5pF	1.00	0.50	0.50
GRM615C0G110G50	50	C0G	11 -2%	1.00	0.50	0.50
GRM615C0G120G50	50	C0G	12 -2%	1.00	0.50	0.50
GRM615C0G120J50	50	C0G	12 -5%	1.00	0.50	0.50
GRM615C0G130G50	50	C0G	13 -2%	1.00	0.50	0.50
GRM615C0G150G50	50	C0G	15 -2%	1.00	0.50	0.50
GRM615C0G150J50	50	C0G	15 -5%	1.00	0.50	0.50
GRM615C0G160G50	50	C0G	16 -2%	1.00	0.50	0.50
GRM615C0G180G50	50	C0G	18 -2%	1.00	0.50	0.50
GRM615C0G180J50	50	C0G	18 -5%	1.00	0.50	0.50
GRM615C0G1R1B50	50	C0G	1.1 -0.1pF	1.00	0.50	0.50
GRM615C0G1R2B50	50	C0G	1.2 -0.1pF	1.00	0.50	0.50
GRM615C0G1R3B50	50	C0G	1.3 -0.1pF	1.00	0.50	0.50
GRM615C0G1R5B50	50	C0G	1.5 -0.1pF	1.00	0.50	0.50
GRM615C0G1R5C50	50	C0G	1.5 -0.25pF	1.00	0.50	0.50
GRM615C0G1R6B50	50	C0G	1.6 -0.1pF	1.00	0.50	0.50
GRM615C0G1R8B50	50	C0G	1.8 -0.1pF	1.00	0.50	0.50

Continued on the following page.

 Continued from the preceding page.

Part Number	Rated Voltage (Vdc)	TC Code	Capacitance (pF)	Length L (mm)	Width W (mm)	Thickness T (mm)
<b>GRM615C0G200G50</b>	50	C0G	20 -2%	1.00	0.50	0.50
<b>GRM615C0G2R2B50</b>	50	C0G	2.2 -0.1pF	1.00	0.50	0.50
<b>GRM615C0G2R4B50</b>	50	C0G	2.4 -0.1pF	1.00	0.50	0.50
<b>GRM615C0G2R7B50</b>	50	C0G	2.7 -0.1pF	1.00	0.50	0.50
<b>GRM615C0G3R3B50</b>	50	C0G	3.3 -0.1pF	1.00	0.50	0.50
<b>GRM615C0G3R6B50</b>	50	C0G	3.6 -0.1pF	1.00	0.50	0.50
<b>GRM615C0G3R9B50</b>	50	C0G	3.9 -0.1pF	1.00	0.50	0.50
<b>GRM615C0G4R3B50</b>	50	C0G	4.3 -0.1pF	1.00	0.50	0.50
<b>GRM615C0G4R7B50</b>	50	C0G	4.7 -0.1pF	1.00	0.50	0.50
<b>GRM615C0G5R1C50</b>	50	C0G	5.1 -0.25pF	1.00	0.50	0.50
<b>GRM615C0G5R6C50</b>	50	C0G	5.6 -0.25pF	1.00	0.50	0.50
<b>GRM615C0G6R2C50</b>	50	C0G	6.2 -0.25pF	1.00	0.50	0.50
<b>GRM615C0G6R8C50</b>	50	C0G	6.8 -0.25pF	1.00	0.50	0.50
<b>GRM615C0G7R5C50</b>	50	C0G	7.5 -0.25pF	1.00	0.50	0.50
<b>GRM615C0G8R2C50</b>	50	C0G	8.2 -0.25pF	1.00	0.50	0.50
<b>GRM615C0G9R1C50</b>	50	C0G	9.1 -0.25pF	1.00	0.50	0.50

DataSheet4U.com

DataSheet4U.com

DataSheet4U.com

DataSheet4U.com

www.DataSheet4U.com

DataSheet4U.com

## Specifications and Test Methods

No.	Item	Specification		Test Method												
		Temperature Compensating Type														
1	Operating Temperature Range	-55 to +125°C														
2	Rated Voltage	See the previous pages.		The rated voltage is defined as the maximum voltage which may be applied continuously to the capacitor. When AC voltage is superimposed on DC voltage, $V^{P-P}$ or $V^{O-P}$ , whichever is larger, shall be maintained within the rated voltage range.												
3	Appearance	No defects or abnormalities.		Visual inspection.												
4	Dimensions	Within the specified dimensions.		Using calipers.												
5	Dielectric Strength	No defects or abnormalities.		No failure shall be observed when 300% of the rated voltage is applied between the terminations for 1 to 5 seconds, provided the charge/discharge current is less than 50mA.												
6	Insulation Resistance (I.R.)	10,000MΩ min. or $500\Omega \cdot F$ min. (Whichever is smaller)		The insulation resistance shall be measured with a DC voltage not exceeding the rated voltage at 25°C and 75%RH max. and within 2 minutes of charging.												
7	Capacitance	Within the specified tolerance.		The capacitance/Q shall be measured at 25°C at the frequency and voltage shown in the table.												
8	Q	30pF min. : $Q \geq 1,000$ 30pF max. : $Q \geq 400+20C$ C : Nominal Capacitance (pF)		<table border="1"> <thead> <tr> <th>Item</th> <th>Char.</th> <th>C0G(1000pF and below)</th> </tr> </thead> <tbody> <tr> <td>Frequency</td> <td></td> <td>1±0.1MHz</td> </tr> <tr> <td>Voltage</td> <td></td> <td>0.5 to 5Vr.m.s.</td> </tr> </tbody> </table>	Item	Char.	C0G(1000pF and below)	Frequency		1±0.1MHz	Voltage		0.5 to 5Vr.m.s.			
Item	Char.	C0G(1000pF and below)														
Frequency		1±0.1MHz														
Voltage		0.5 to 5Vr.m.s.														
9	Capacitance Temperature Characteristics	Capacitance Change	Within the specified tolerance. (Table A-1)	<p>The capacitance change shall be measured after 5 min. at each specified temperature stage.</p> <p>Temperature Compensating Type</p> <p>The temperature coefficient is determined using the capacitance measured in step 3 as a reference.</p> <p>When cycling the temperature sequentially from step 1 through 5, (C0G : +25°C to +125°C : other temp. coeffs. : +25°C to 85°C) the capacitance shall be within the specified tolerance for the temperature coefficient and capacitance change as Table A. The capacitance drift is calculated by dividing the differences between the maximum and minimum measured values in the step 1, 3 and 5 by the cap value in step 3.</p> <table border="1"> <thead> <tr> <th>Step</th> <th>Temperature(°C)</th> </tr> </thead> <tbody> <tr> <td>1</td> <td>25±2</td> </tr> <tr> <td>2</td> <td>-55±3</td> </tr> <tr> <td>3</td> <td>25±2</td> </tr> <tr> <td>4</td> <td>125±3</td> </tr> <tr> <td>5</td> <td>25±2</td> </tr> </tbody> </table>	Step	Temperature(°C)	1	25±2	2	-55±3	3	25±2	4	125±3	5	25±2
		Step	Temperature(°C)													
		1	25±2													
2	-55±3															
3	25±2															
4	125±3															
5	25±2															
Temperature Coefficient	Within the specified tolerance. (Table A-1)															
Capacitance Drift	Within ±0.2% or ±0.05pF (Whichever is larger.)															
10	Adhesive Strength of Termination	No removal of the terminations or other defect shall occur.		<p>Solder the capacitor to the test jig (glass epoxy board) shown in Fig.1 using a eutectic solder. Then apply a 5N force in parallel with the test jig for 10±1sec.</p> <p>The soldering shall be done either with an iron or using the reflow method and shall be conducted with care so that the soldering is uniform and free of defects such as heat shock.</p>  <table border="1"> <thead> <tr> <th>Type</th> <th>a</th> <th>b</th> <th>c</th> </tr> </thead> <tbody> <tr> <td>GRM615</td> <td>0.4</td> <td>1.5</td> <td>0.5</td> </tr> </tbody> </table> <p>(in mm)</p>	Type	a	b	c	GRM615	0.4	1.5	0.5				
Type	a	b	c													
GRM615	0.4	1.5	0.5													

Fig.1

Continued on the following page. 

## Specifications and Test Methods

Continued from the preceding page.

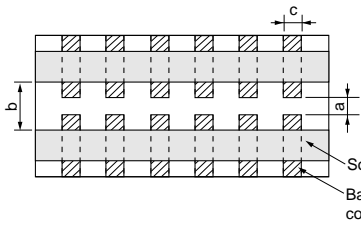
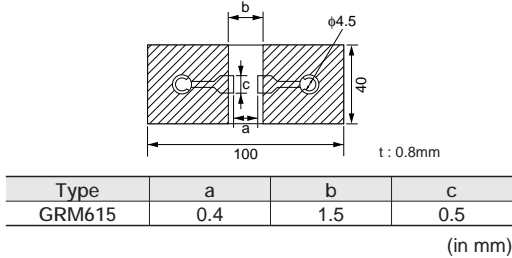
No.	Item	Specification		Test Method					
		Temperature Compensating Type							
11	Vibration Resistance	Appearance	No defects or abnormalities.	Solder the capacitor to the test jig (glass epoxy board) in the same manner and under the same conditions as (10). The capacitor shall be subjected to a simple harmonic motion having a total amplitude of 1.5mm, the frequency being varied uniformly between the approximate limits of 10 and 55Hz. The frequency range, from 10 to 55Hz and return to 10Hz, shall be traversed in approximately 1 minute. This motion shall be applied for a period of 2 hours in each 3 mutually perpendicular directions (total of 6 hours).					
		Capacitance	Within the specified tolerance.						
		Q	30pF min. : $Q \geq 1,000$ 30pF max. : $Q \geq 400+20C$ C : Nominal Capacitance (pF)						
12	Deflection	No cracking or marking defects shall occur.		Solder the capacitor to the test jig (glass epoxy boards) shown in Fig.2 using a eutectic solder. Then apply a force in the direction shown in Fig.3. The soldering shall be done either with an iron or using the reflow method and shall be conducted with care so that the soldering is uniform and free of defects such as heat shock..					
		 <table border="1" data-bbox="368 869 882 920"> <thead> <tr> <th>Type</th> <th>a</th> <th>b</th> <th>c</th> </tr> </thead> <tbody> <tr> <td>GRM615</td> <td>0.4</td> <td>1.5</td> <td>0.5</td> </tr> </tbody> </table> <p style="text-align: center;">(in mm)</p>			Type	a	b	c	GRM615
Type	a	b	c						
GRM615	0.4	1.5	0.5						
13	Solderability of Termination	75% of the terminations is to be soldered evenly and continuously.		Immerse the capacitor in a solution of ethanol (JIS-K-8101) and rosin (JIS-K-5902) (25% rosin in weight proportion). Preheat at 80 to 120°C for 10 to 30 seconds. After preheating, immerse in eutectic solder solution for $2 \pm 0.5$ seconds at $230 \pm 5^\circ\text{C}$ .					
14	Resistance to Soldering Heat	The measured and observed characteristics shall satisfy the specifications in the following table.		Preheat the capacitor at 120 to 150°C for 1 minute. Immerse the capacitor in a eutectic solder solution at $270 \pm 5^\circ\text{C}$ for $10 \pm 0.5$ seconds. Let sit at room temperature for $24 \pm 2$ hours.					
		Appearance	No marking defects.						
		Capacitance Change	Within $\pm 2.5\%$ or $\pm 0.25\text{pF}$ (Whichever is larger)						
		Q	30pF and over : $Q \geq 1,000$ 30pF and below : $Q \geq 400+20C$ C : Nominal Capacitance (pF)						
		I.R.	More than 10,000M $\Omega$ or 500 $\Omega \cdot F$ (Whichever is smaller)						
15	Temperature Cycle	The measured and observed characteristics shall satisfy the specifications in the following table.		Fix the capacitor to the supporting jig in the same manner and under the same conditions as (10). Perform the five cycles according to the four heat treatments listed in the following table. Let sit for $24 \pm 2$ hours at room temperature, then measure.					
		Appearance	No marking defects.						
		Capacitance Change	Within $\pm 2.5\%$ or $\pm 0.25\text{pF}$ (Whichever is larger)						
		Q	30pF and over : $Q \geq 1,000$ 30pF and below : $Q \geq 400+20C$ C : Nominal Capacitance (pF)						
		I.R.	More than 10,000M $\Omega$ or 500 $\Omega \cdot F$ (Whichever is smaller)						
16	Humidity, Steady State	The measured and observed characteristics shall satisfy the specifications in the following table.		Sit the capacitor at $40 \pm 2^\circ\text{C}$ and 90 to 95% humidity for $500 \pm 12$ hours. Remove and let sit for $24 \pm 2$ hours (temperature compensating type) at room temperature, then measure.					
		Appearance	No marking defects.						
		Capacitance Change	Within $\pm 5\%$ or $\pm 0.5\text{pF}$ (Whichever is larger)						
		Q	30pF and over. : $Q \geq 350$ 10pF and over, 30pF and below : $Q \geq 275 + \frac{C}{3}$ 10pF and below : $Q \geq 200+10C$ C : Nominal Capacitance (pF)						
		I.R.	More than 10,000M $\Omega$ or 500 $\Omega \cdot F$ (Whichever is smaller)						

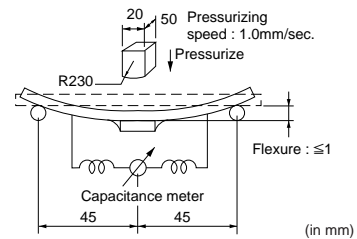



Fig.3



## Specifications and Test Methods

 Continued from the preceding page.

No.	Item	Specification		Test Method
		Temperature Compensating Type		
17	Humidity Load	The measured and observed characteristics shall satisfy the specifications in the following table.		Apply the rated voltage at 40±2°C and 90 to 95% humidity for 500±12 hours. Remove and let sit for 24±2 hours at room temperature, then measure. The charge/discharge current is less than 50mA.
		Appearance	No marking defects.	
		Capacitance Change	Within ±7.5% or ±0.75pF (Whichever is larger)	
		Q	30pF and over : $Q \geq 200$ 30pF and below : $Q \geq 100 + \frac{1}{C} C$ C : Nominal Capacitance (pF)	
		I.R.	More than 500MΩ or 25Ω • F (Whichever is smaller)	
	Dielectric Strength	No failure		
18	High Temperature Load	The measured and observed characteristics shall satisfy the specifications in the following table.		Apply 200% of the rated voltage for 1000±12 hours at the maximum operating temperature ±3°C. Let sit for 24±2 hours (temperature compensating type) at room temperature, then measure. The charge/discharge current is less than 50mA.
		Appearance	No marking defects.	
		Capacitance Change	Within ±3% or ±0.3pF (Whichever is larger)	
		Q	30pF and over. : $Q \geq 350$ 10pF and over, 30pF and below : $Q \geq 275 + \frac{5}{C} C$ 10pF and below : $Q \geq 200 + 10C$ C : Nominal Capacitance (pF)	
		I.R.	More than 1,000MΩ or 50Ω • F (Whichever is smaller)	
	Dielectric Strength	No failure		
19	ESR	0.5pF < C ≤ 1pF : 350MΩ . pF below 1pF < C ≤ 5pF : 300MΩ below 5pF < C ≤ 10pF : 250MΩ below		The ESR shall be measured at room Temp. and frequency 1±0.2GHz with the equivalent of BOONTON Model 34A.
		10pF < C ≤ 20pF : 400MΩ below		The ESR shall be measured at room Temp. and frequency 500±50MHz with the equivalent of HP8753B.

Table A

Char.	Temp. Coeff. (ppm/°C) Note 1	Capacitance Change from 25°C Value (%)					
		-55°C		-30°C		-10°C	
		Max.	Min.	Max.	Min.	Max.	Min.
COG	0±30	0.58	-0.24	0.40	-0.17	0.25	-0.11

Note 1 : Nominal values denote the temperature coefficient within a range of 25 to 125°C.(for C0A)

# GRM Series Data

## Capacitance-Temperature Characteristics

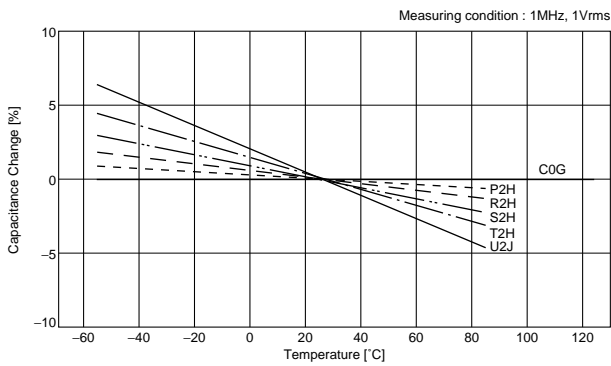

## Capacitance-DC Voltage Characteristics

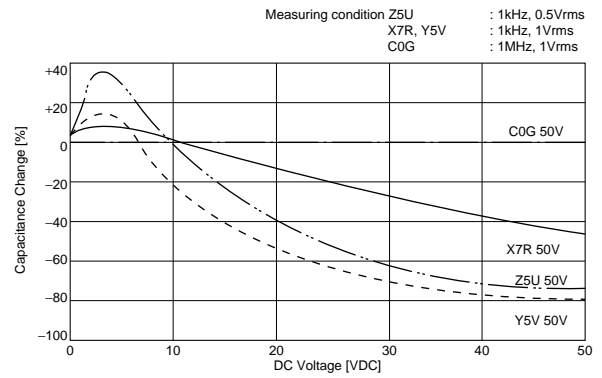

## Capacitance-AC Voltage Characteristics

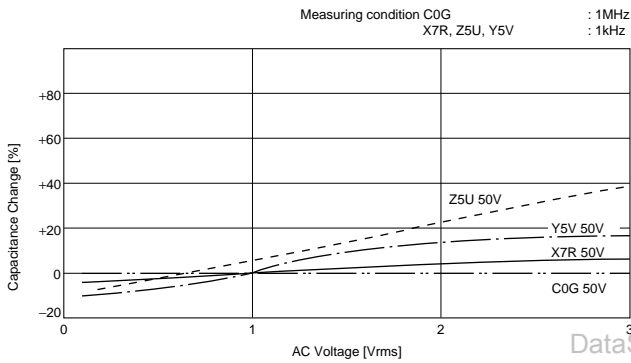

## Capacitance Change-Aging

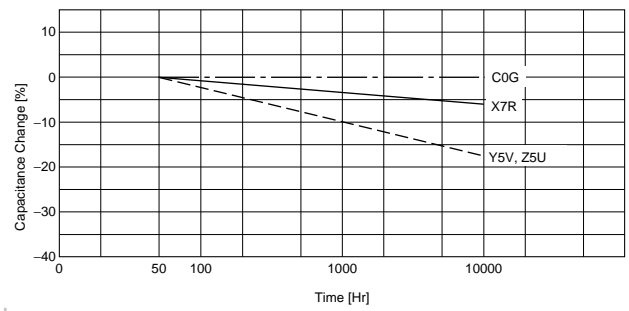

## Impedance-Frequency Characteristics

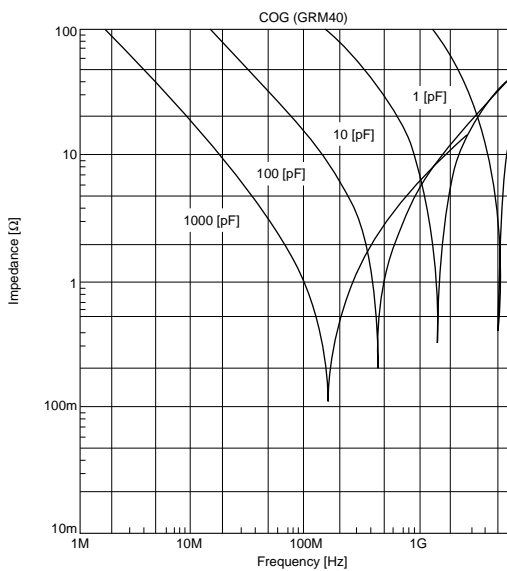

## Allowable Voltage-Frequency

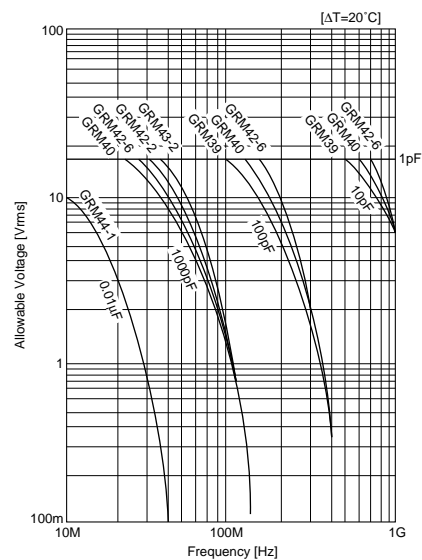

Continued on the following page.

# GRM Series Data

Continued from the preceding page.

## Allowable Current-Frequency

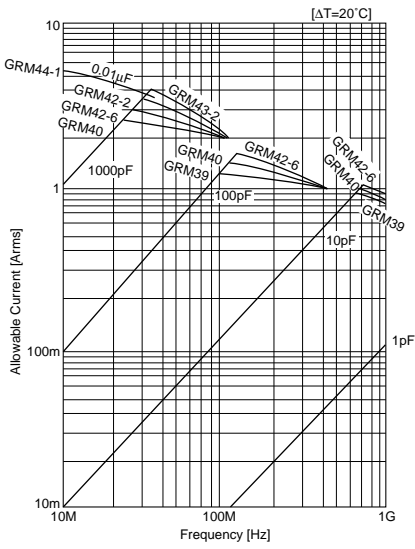

## Allowable Apparent Power

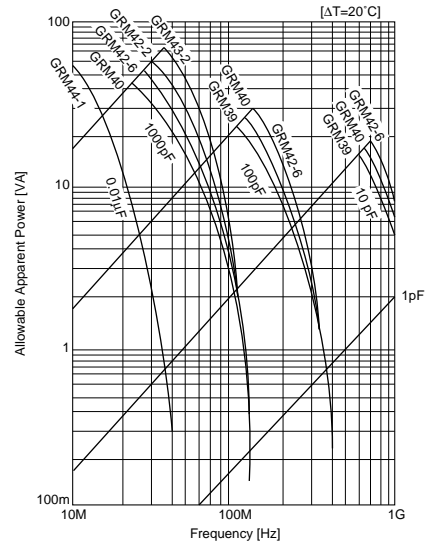

DataSheet4U.com

et4U.com

DataShee

# CHIP MONOLITHIC CERAMIC CAPACITOR



## Low ESL Wide-width Type LL Series

### ■ Features

1. Low ESL, good for noise reduction for high frequency.
2. Small, high cap.

### ■ Application

- High speed micro processor.
- High frequency digital equipment

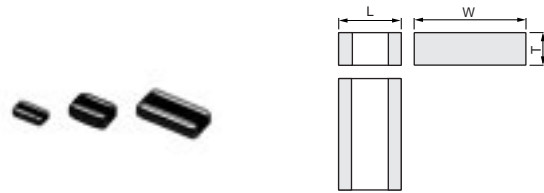

Part Number	Dimensions (mm)		
	L	W	T
<b>LL0306</b>	0.8 ±0.1	1.6 ±0.1	0.6 max. 0.6 ±0.1
<b>LL0508</b>	1.25 ±0.1	2.0 ±0.1	0.85 ±0.1 0.7 ±0.1
<b>LL0612</b>	1.6 ±0.15	3.2 ±0.15	1.15 ±0.1

### LL0306 Series

Part Number	LL0306							
L x W(mm)	0.8x1.6							
TC Code	X7R				Y5V		Z5U	
Rated Volt.(Vdc)	10	16	25	50	16	50	25	50
Capacitance and T(mm)								
2200pF				0.6				
2700pF				0.6				
3300pF				0.6				
3900pF				0.6				
4700pF				0.6				
5600pF				0.6				
6800pF			0.6					
8200pF			0.6					
10000pF			0.6					0.6
12000pF			0.6					
15000pF			0.6			0.6	0.6	
18000pF			0.6					
22000pF			0.6			0.6	0.6	
27000pF		0.6						
33000pF		0.6			0.6			
39000pF		0.6						
47000pF		0.6			0.6			
56000pF		0.6						
68000pF		0.6			0.6			
82000pF	0.6							
0.1μF	0.6							

### LL0508 Series

Part Number	LL0508								
L x W(mm)	1.25x2.0								
TC Code	X7R				Y5V		Z5U		
Rated Volt.(Vdc)	10	16	25	50	16	25	50	25	50
Capacitance and T(mm)									
0.15pF								0.85	
0.22pF	0.6								
4700pF				0.6					

Continued on the following page. 

 Continued from the preceding page.

Part Number	LL0508								
L x W(mm)	1.25x2.0								
TC Code	X7R				Y5V			Z5U	
Rated Volt.(Vdc)	10	16	25	50	16	25	50	25	50
<b>Capacitance and T(mm)</b>									
5600pF				0.6					
6800pF				0.6					
8200pF				0.6					
10000pF				0.6					
12000pF				0.6					
15000pF				0.6					
18000pF				0.6					
22000pF				0.6					
27000pF			0.6	0.85					
33000pF		0.6	0.6	0.85					0.6
39000pF		0.6	0.6	0.85					
47000pF		0.6	0.6					0.6	0.85
56000pF		0.6	0.6						
68000pF		0.6	0.6				0.6	0.6	0.85
82000pF		0.6	0.6						
0.1μF		0.6	0.6			0.6	0.85	0.85	
0.12μF		0.6							
0.15μF		0.6	0.85		0.6	0.85		0.85	
0.18μF		0.6							
0.22μF		0.85			0.6				
0.27μF	0.6								
0.33μF	0.6				0.85				
0.39μF	0.85								
0.47μF	0.85								
0.56μF	0.85								

### LL0612 Series

Part Number	LL0612								
L x W(mm)	1.6x3.2								
TC Code	X7R				Y5V			Z5U	
Rated Volt.(Vdc)	10	16	25	50	16	25	50	25	50
<b>Capacitance and T(mm)</b>									
10000pF				0.7					
12000pF				0.7					
15000pF				0.7					
18000pF				0.7					
22000pF				0.7					
27000pF				0.7					
33000pF				0.7					
39000pF				0.7					
47000pF				0.7					
56000pF				0.7					
68000pF				0.7					
82000pF			0.7	1.15					
0.1μF		0.7	0.7	1.15					0.7
0.12μF		0.7	0.7	1.15					
0.15μF		0.7	0.7					0.7	1.15
0.18μF		0.7	0.7						
0.22μF		0.7	1.15				0.7	0.7	1.15
0.27μF		0.7	1.15						
0.33μF		0.7	1.15				1.15	1.15	
0.39μF		0.7							

Continued on the following page. 

 Continued from the preceding page.

Part Number	LL0612								
L x W(mm)	1.6x3.2								
TC Code	X7R				Y5V			Z5U	
Rated Volt.(Vdc)	10	16	25	50	16	25	50	25	50
Capacitance and T(mm)									
0.47μF		0.7	1.15		0.7	1.15		1.15	
0.56μF	0.7	1.15							
0.68μF	0.7	1.15			0.7				
0.82μF	0.7	1.15							
1000000pF	0.7	1.15			1.15				
1.2μF	1.15								
1.5μF	1.15								
1.8μF	1.15								
2.2μF	1.15								

DataSheet4U.com

et4U.com

DataShee

## Specifications and Test Methods

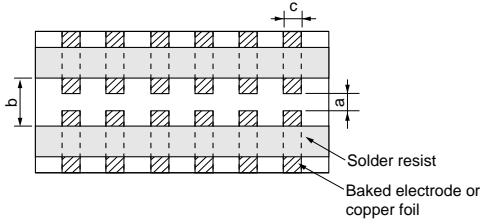
No.	Item	Specification	Test Method																						
1	Operating Temperature Range	X7R : -55°C to +125°C Z5U : +10°C to +85°C Y5V : -30°C to +85°C																							
2	Rated Voltage	See the previous pages.	The rated voltage is defined as the maximum voltage which may be applied continuously to the capacitor. When AC voltage is superimposed on DC voltage, $V^{P-P}$ or $V^{0-P}$ , whichever is larger, shall be maintained within the rated voltage range.																						
3	Appearance	No defects or abnormalities.	Visual inspection.																						
4	Dimensions	Within the specified dimension.	Using calipers.																						
5	Dielectric Strength	No defects or abnormalities.	No failure shall be observed when 250% of the rated voltage is applied between the terminations for 1 to 5 seconds, provided the charge/discharge current is less than 50mA.																						
6	Insulation Resistance (I.R.)	More than 10,000MΩ or 500Ω • F (Whichever is smaller)	The insulation resistance shall be measured with a DC voltage not exceeding the rated voltage at 25°C and 75%RH max. and within 2 minutes of charging.																						
7	Capacitance	Within the specified tolerance.	The capacitance/D.F. shall be measured at 25°C at the frequency and voltage shown in the table.																						
8	Dissipation Factor (D.F.)	<table border="1" style="width: 100%; border-collapse: collapse;"> <thead> <tr> <th>Char.</th> <th>25V min.</th> <th>16V</th> </tr> </thead> <tbody> <tr> <td>X7R</td> <td>0.025 max.</td> <td>0.035 max.</td> </tr> <tr> <td>Z5U</td> <td>0.025 max.</td> <td>—</td> </tr> <tr> <td rowspan="2">Y5V</td> <td rowspan="2">0.05 max.</td> <td>0.07 max. (C&lt;1.0μF)</td> </tr> <tr> <td>0.09 max. (C≥1.0μF)</td> </tr> </tbody> </table>		Char.	25V min.	16V	X7R	0.025 max.	0.035 max.	Z5U	0.025 max.	—	Y5V	0.05 max.	0.07 max. (C<1.0μF)	0.09 max. (C≥1.0μF)	<table border="1" style="width: 100%; border-collapse: collapse;"> <thead> <tr> <th></th> <th>X7R · Y5V</th> <th>Z5U</th> </tr> </thead> <tbody> <tr> <td>Frequency</td> <td>1±0.1kHz</td> <td>1±0.1kHz</td> </tr> <tr> <td>Voltage</td> <td>1±0.2Vr.m.s.</td> <td>0.5±0.05Vr.m.s.</td> </tr> </tbody> </table>		X7R · Y5V	Z5U	Frequency	1±0.1kHz	1±0.1kHz	Voltage	1±0.2Vr.m.s.
Char.		25V min.	16V																						
X7R	0.025 max.	0.035 max.																							
Z5U	0.025 max.	—																							
Y5V	0.05 max.	0.07 max. (C<1.0μF)																							
		0.09 max. (C≥1.0μF)																							
	X7R · Y5V	Z5U																							
Frequency	1±0.1kHz	1±0.1kHz																							
Voltage	1±0.2Vr.m.s.	0.5±0.05Vr.m.s.																							
9	Capacitance Temperature Characteristics	<table border="1" style="width: 100%; border-collapse: collapse;"> <thead> <tr> <th>Char.</th> <th>Temp. Range (°C)</th> <th>Reference Temp.</th> <th>Cap. Change.</th> </tr> </thead> <tbody> <tr> <td>X7R</td> <td>-55 to +125</td> <td rowspan="3">25°C</td> <td>Within±15%</td> </tr> <tr> <td>Z5U</td> <td>+10 to +85</td> <td>Within+22%/-56%</td> </tr> <tr> <td>Y5V</td> <td>-30 to +85</td> <td>Within+22%/-82%</td> </tr> </tbody> </table>	Char.	Temp. Range (°C)	Reference Temp.	Cap. Change.	X7R	-55 to +125	25°C	Within±15%	Z5U	+10 to +85	Within+22%/-56%	Y5V	-30 to +85	Within+22%/-82%	The ranges of capacitance change compared with the 25°C value over the temperature ranges shown in the table shall be within the specified ranges. The capacitance change shall be measured after 5 min. at each specified temperature stage.								
Char.	Temp. Range (°C)	Reference Temp.	Cap. Change.																						
X7R	-55 to +125	25°C	Within±15%																						
Z5U	+10 to +85		Within+22%/-56%																						
Y5V	-30 to +85		Within+22%/-82%																						
10	Adhesive Strength of Termination	No removal of the terminations or other defect shall occur.	<p>Solder the capacitor to the test jig (glass epoxy board) shown in Fig.1 using a eutectic solder. Then apply 10N* force in the direction of the arrow. *5N:LL0306</p> <p>The soldering shall be done either with an iron or using the reflow method and shall be conducted with care so that the soldering is uniform and free of defects such as heat shock.</p>  <table border="1" style="width: 100%; border-collapse: collapse; margin-top: 10px;"> <thead> <tr> <th>Type</th> <th>a</th> <th>b</th> <th>c</th> </tr> </thead> <tbody> <tr> <td>LL0306</td> <td>0.3</td> <td>1.2</td> <td>2.0</td> </tr> <tr> <td>LL0508</td> <td>0.6</td> <td>1.6</td> <td>2.4</td> </tr> <tr> <td>LL0612</td> <td>1.0</td> <td>3.0</td> <td>3.7</td> </tr> </tbody> </table> <p style="text-align: right;">(in mm)</p> <p style="text-align: center;">Fig.1</p>	Type	a	b	c	LL0306	0.3	1.2	2.0	LL0508	0.6	1.6	2.4	LL0612	1.0	3.0	3.7						
Type	a	b	c																						
LL0306	0.3	1.2	2.0																						
LL0508	0.6	1.6	2.4																						
LL0612	1.0	3.0	3.7																						
11	Appearance	No defects or abnormalities.	Solder the capacitor to the test jig (glass epoxy board) in the same manner and under the same conditions as (10). The capacitor shall be subjected to a simple harmonic motion having a total amplitude of 1.5mm, the frequency being varied uniformly between the approximate limits of 10 and 55Hz. The frequency range, from 10 to 55Hz and return to 10Hz, shall be traversed in approximately 1 minute. This motion shall be applied for a period of 2 hours in each 3 mutually perpendicular directions (total of 6 hours).																						
	Capacitance	Within the specified tolerance.																							
	D.F.	<table border="1" style="width: 100%; border-collapse: collapse;"> <thead> <tr> <th>Char.</th> <th>25V min.</th> <th>16V</th> </tr> </thead> <tbody> <tr> <td>X7R</td> <td>0.025 max.</td> <td>0.035 max.</td> </tr> <tr> <td>Z5U</td> <td>0.025 max.</td> <td>—</td> </tr> <tr> <td rowspan="2">Y5V</td> <td rowspan="2">0.05 max.</td> <td>0.07 max. (C&lt;1.0μF)</td> </tr> <tr> <td>0.09 max. (C≥1.0μF)</td> </tr> </tbody> </table>		Char.	25V min.	16V	X7R	0.025 max.	0.035 max.	Z5U	0.025 max.	—	Y5V	0.05 max.	0.07 max. (C<1.0μF)	0.09 max. (C≥1.0μF)									
Char.	25V min.	16V																							
X7R	0.025 max.	0.035 max.																							
Z5U	0.025 max.	—																							
Y5V	0.05 max.	0.07 max. (C<1.0μF)																							
		0.09 max. (C≥1.0μF)																							

Continued on the following page.

## Specifications and Test Methods

Continued from the preceding page.

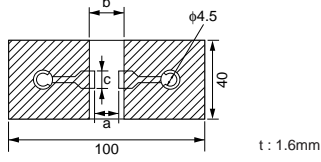
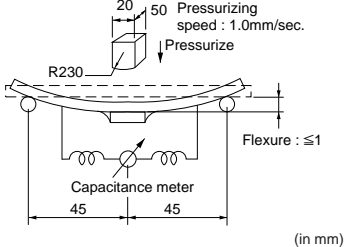
No.	Item	Specification	Test Method															
12	Deflection	No crack or marked defect shall occur.	<p>Solder the capacitor to the test jig (glass epoxy boards) shown in Fig.2 using a eutectic solder.</p> <p>Then apply a force in the direction shown in Fig.3.</p> <p>The soldering shall be done either with an iron or using the reflow method and shall be conducted with care so that the soldering is uniform and free of defects such as heat shock.</p>															
		 <table border="1" style="margin: 10px auto;"> <thead> <tr> <th>Type</th> <th>a</th> <th>b</th> <th>c</th> </tr> </thead> <tbody> <tr> <td>LL0306</td> <td>0.3</td> <td>1.2</td> <td>2.0</td> </tr> <tr> <td>LL0508</td> <td>0.6</td> <td>1.6</td> <td>2.4</td> </tr> <tr> <td>LL0612</td> <td>1.0</td> <td>3.0</td> <td>3.7</td> </tr> </tbody> </table> <p style="text-align: center;">(in mm)</p>		Type	a	b	c	LL0306	0.3	1.2	2.0	LL0508	0.6	1.6	2.4	LL0612	1.0	3.0
Type	a	b	c															
LL0306	0.3	1.2	2.0															
LL0508	0.6	1.6	2.4															
LL0612	1.0	3.0	3.7															
		Fig.2	 <p style="text-align: center;">(in mm)</p> <p style="text-align: center;">Fig.3</p>															
13	Solderability of Termination	75% of the terminations is to be soldered evenly and continuously.	<p>Immerse the capacitor in a solution of ethanol (JIS-K-8101) and rosin (JIS-K-5902) (25% rosin in weight proportion). Preheat at 80 to 120°C for 10 to 30 seconds. After preheating, immerse in eutectic solder solution for 2±0.5 seconds at 230±5°C.</p>															
14	Resistance to Soldering Heat	Appearance	No defects or abnormalities.															
		Capacitance Change	X7R : Within±7.5% Z5U · Y5V : Within±20%															
		D.F.	<table border="1" style="margin: 5px auto;"> <thead> <tr> <th>Char.</th> <th>25V min.</th> <th>16V</th> </tr> </thead> <tbody> <tr> <td>X7R</td> <td>0.025 max.</td> <td>0.035 max.</td> </tr> <tr> <td>Z5U</td> <td>0.025 max.</td> <td>—</td> </tr> <tr> <td rowspan="2">Y5V</td> <td rowspan="2">0.05 max.</td> <td>0.07 max. (C&lt;1.0μF)</td> </tr> <tr> <td>0.09 max. (C≥1.0μF)</td> </tr> </tbody> </table>	Char.	25V min.	16V	X7R	0.025 max.	0.035 max.	Z5U	0.025 max.	—	Y5V	0.05 max.	0.07 max. (C<1.0μF)	0.09 max. (C≥1.0μF)		
		Char.	25V min.	16V														
		X7R	0.025 max.	0.035 max.														
Z5U	0.025 max.	—																
Y5V	0.05 max.	0.07 max. (C<1.0μF)																
		0.09 max. (C≥1.0μF)																
I.R.	More than 10,000MΩ or 500Ω · F (Whichever is smaller)																	
Dielectric Strength	No failure																	
15	Temperature Cycle	Appearance	No defects or abnormalities.															
		Capacitance Change	X7R : Within±7.5% Z5U · Y5V : Within±20%															
		D.F.	<table border="1" style="margin: 5px auto;"> <thead> <tr> <th>Char.</th> <th>25V min.</th> <th>16V</th> </tr> </thead> <tbody> <tr> <td>X7R</td> <td>0.025 max.</td> <td>0.035 max.</td> </tr> <tr> <td>Z5U</td> <td>0.025 max.</td> <td>—</td> </tr> <tr> <td rowspan="2">Y5V</td> <td rowspan="2">0.05 max.</td> <td>0.07 max. (C&lt;1.0μF)</td> </tr> <tr> <td>0.09 max. (C≥1.0μF)</td> </tr> </tbody> </table>	Char.	25V min.	16V	X7R	0.025 max.	0.035 max.	Z5U	0.025 max.	—	Y5V	0.05 max.	0.07 max. (C<1.0μF)	0.09 max. (C≥1.0μF)		
		Char.	25V min.	16V														
		X7R	0.025 max.	0.035 max.														
Z5U	0.025 max.	—																
Y5V	0.05 max.	0.07 max. (C<1.0μF)																
		0.09 max. (C≥1.0μF)																
I.R.	More than 10,000MΩ or 500Ω · F (Whichever is smaller)																	
Dielectric Strength	No failure																	
16	Humidity, Steady State	Appearance	No defects or abnormalities.															
		Capacitance Change	X7R : Within±12.5% Z5U · Y5V : Within±30%															
		D.F.	<table border="1" style="margin: 5px auto;"> <thead> <tr> <th>Char.</th> <th>25V min.</th> <th>16V</th> </tr> </thead> <tbody> <tr> <td>X7R</td> <td>0.05 max.</td> <td>0.05 max.</td> </tr> <tr> <td>Z5U</td> <td>0.05 max.</td> <td>—</td> </tr> <tr> <td rowspan="2">Y5V</td> <td rowspan="2">0.075 max.</td> <td>0.1 max. (C&lt;1.0μF)</td> </tr> <tr> <td>0.125 max. (C≥1.0μF)</td> </tr> </tbody> </table>	Char.	25V min.	16V	X7R	0.05 max.	0.05 max.	Z5U	0.05 max.	—	Y5V	0.075 max.	0.1 max. (C<1.0μF)	0.125 max. (C≥1.0μF)		
		Char.	25V min.	16V														
		X7R	0.05 max.	0.05 max.														
Z5U	0.05 max.	—																
Y5V	0.075 max.	0.1 max. (C<1.0μF)																
		0.125 max. (C≥1.0μF)																
I.R.	More than 1,000MΩ or 50Ω · F (Whichever is smaller)																	
			<p>Preheat the capacitor at 120 to 150°C for 1 minute. Immerse the capacitor in a eutectic solder solution at 270±5°C for 10±0.5 seconds. Let sit at room temperature for 48±4 hours, then measure.</p> <p>•Initial measurement. Perform a heat treatment at 150±10 °C for one hour and then let sit for 48±4 hours at room temperature. Perform the initial measurement.</p> <p>Fix the capacitor to the supporting jig in the same manner and under the same conditions as (10). Perform the five cycles according to the four heat treatments listed in the following table. Let sit for 48±4 hours at room temperature, then measure.</p> <table border="1" style="margin: 10px auto;"> <thead> <tr> <th>Step</th> <th>1</th> <th>2</th> <th>3</th> <th>4</th> </tr> </thead> <tbody> <tr> <td>Temp.(°C)</td> <td>Min. Operating Temp. <math>\pm 3</math></td> <td>Room Temp.</td> <td>Max. Operating Temp. <math>\pm 3</math></td> <td>Room Temp.</td> </tr> <tr> <td>Time(min.)</td> <td>30±3</td> <td>2 to 3</td> <td>30±3</td> <td>2 to 3</td> </tr> </tbody> </table> <p>•Initial measurement. Perform a heat treatment at 150±10 °C for one hour and then let sit for 48±4 hours at room temperature. Perform the initial measurement.</p> <p>Sit the capacitor at 40±2°C and 90 to 95% humidity for 500±12 hours. Remove and let sit for 48±4 hours at room temperature, then measure.</p>	Step	1	2	3	4	Temp.(°C)	Min. Operating Temp. $\pm 3$	Room Temp.	Max. Operating Temp. $\pm 3$	Room Temp.	Time(min.)	30±3	2 to 3	30±3	2 to 3
Step	1	2	3	4														
Temp.(°C)	Min. Operating Temp. $\pm 3$	Room Temp.	Max. Operating Temp. $\pm 3$	Room Temp.														
Time(min.)	30±3	2 to 3	30±3	2 to 3														

Continued on the following page.



## Specifications and Test Methods

 Continued from the preceding page.

No.	Item	Specification	Test Method													
17	Humidity Load	Appearance	No defects or abnormalities.													
		Capacitance Change	X7R : Within±12.5% Z5U · Y5V : Within±30%													
		D.F.	<table border="1"> <thead> <tr> <th>Char.</th> <th>25V min.</th> <th>16V</th> </tr> </thead> <tbody> <tr> <td>X7R</td> <td>0.05 max.</td> <td>0.05 max.</td> </tr> <tr> <td>Z5U</td> <td>0.05 max.</td> <td>—</td> </tr> <tr> <td>Y5V</td> <td>0.075 max.</td> <td>0.1 max. (C&lt;1.0μF) 0.125 max. (C≥1.0μF)</td> </tr> </tbody> </table>	Char.	25V min.	16V	X7R	0.05 max.	0.05 max.	Z5U	0.05 max.	—	Y5V	0.075 max.	0.1 max. (C<1.0μF) 0.125 max. (C≥1.0μF)	Apply the rated voltage at 40±2°C and 90 to 95% humidity for 500±12 hours. Remove and let sit for 48±4 hours at room temperature, then measure. The charge/discharge current is less than 50mA.
			Char.	25V min.	16V											
			X7R	0.05 max.	0.05 max.											
Z5U	0.05 max.	—														
Y5V	0.075 max.	0.1 max. (C<1.0μF) 0.125 max. (C≥1.0μF)														
I.R.	More than 500MΩ or 25Ω • F (Whichever is smaller)															
Dielectric Strength	No failure															
18	High Temperature Load	Appearance	No defects or abnormalities.													
		Capacitance Change	X7R : Within±12.5% Z5U : Within±30% Y5V : Within±30% (C<1.0μF) Within ±30% (C≥1.0μF)													
		D.F.	<table border="1"> <thead> <tr> <th>Char.</th> <th>25V min.</th> <th>16V</th> </tr> </thead> <tbody> <tr> <td>X7R</td> <td>0.05 max.</td> <td>0.05 max.</td> </tr> <tr> <td>Z5U</td> <td>0.05 max.</td> <td>—</td> </tr> <tr> <td>Y5V</td> <td>0.075 max.</td> <td>0.1 max. (C&lt;1.0μF) 0.125 max. (C≥1.0μF)</td> </tr> </tbody> </table>	Char.	25V min.	16V	X7R	0.05 max.	0.05 max.	Z5U	0.05 max.	—	Y5V	0.075 max.	0.1 max. (C<1.0μF) 0.125 max. (C≥1.0μF)	Apply 200% of the rated voltage for 1,000±12 hours at maximum operating temperature ±3°C. Let sit for 48±4 hours at room temperature, then measure. The charge/discharge current is less than 50mA.  •Initial measurement. Apply 200% of the rated DC voltage for one hour at the maximum operating temperature ±3°C. Remove and let sit for 48±4 hours at room temperature. Perform initial measurement.
			Char.	25V min.	16V											
			X7R	0.05 max.	0.05 max.											
Z5U	0.05 max.	—														
Y5V	0.075 max.	0.1 max. (C<1.0μF) 0.125 max. (C≥1.0μF)														
I.R.	More than 1,000MΩ or 50Ω • F (Whichever is smaller)															
Dielectric Strength	No failure															

6

DataSheet4U.com

et4U.com

DataShee

# CHIP MONOLITHIC CERAMIC CAPACITOR

## Monolithic Microchip GM Series

### ■ Features

1. Better micro wave characteristics.
2. Suitable for by-passing.
3. High density mounting.

### ■ Application

- Optical device for telecommunication.
- IC, IC packaging built-in.
- Measuring equipment.

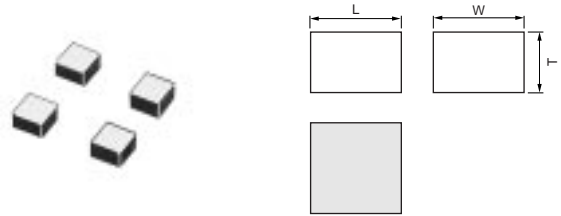

Part Number	Dimensions (mm)		
	L	W	T
<b>GM250</b>	0.5 ±0.05	0.5 ±0.05	0.35 ±0.05
<b>GM260</b>	0.8 ±0.05	0.8 ±0.05	0.5 ±0.1

Part Number	Rated Voltage (Vdc)	TC Code	Capacitance	Length L (mm)	Width W (mm)	Thickness T (mm)
<b>GM250X7R102M16</b>	16	X7R	1000pF	0.5	0.5	0.35
<b>GM250X7R152M16</b>	16	X7R	1500pF	0.5	0.5	0.35
<b>GM250X7R222M16</b>	16	X7R	2200pF	0.5	0.5	0.35
<b>GM250X7R471M50</b>	50	X7R	470pF	0.5	0.5	0.35
<b>GM250Y5V153Z10</b>	10	Y5V	15000pF	0.5	0.5	0.35
<b>GM250Y5V472Z16</b>	16	Y5V	4700pF	0.5	0.5	0.35
<b>GM250Y5V682Z16</b>	16	Y5V	6800pF	0.5	0.5	0.35
<b>GM260X7R103M16</b>	16	X7R	10000pF	0.8	0.8	0.5
<b>GM260Y5V104Z10</b>	10	Y5V	10000pF	0.8	0.8	0.5
<b>GM260Y5V473Z16</b>	16	Y5V	47000pF	0.8	0.8	0.5

7

## Specifications and Test Methods

No.	Item	Specification	Test Method													
1	Operating Temperature	X7R : -55°C to +125°C Y5V : -30°C to +85°C														
2	Rated Voltage	See the previous pages.	The rated voltage is defined as the maximum voltage which may be applied continuously to the capacitor. When AC voltage is superimposed on DC voltage, $V^{P-P}$ or $V^{O-P}$ , whichever is larger, shall be maintained within the rated voltage range.													
3	Appearance	No defects or abnormalities.	Visual inspection.													
4	Dimensions	See the previous pages.	Visual inspection.													
5	Dielectric Strength	No defects or abnormalities.	No failure shall be observed when a voltage of 250% of the rated voltage is applied between the both terminations for 1 to 5 seconds, provided the charge/discharge current is less than 50mA.													
6	Insulation Resistance (I.R.)	10,000MΩ min.	The insulation resistance shall be measured with a DC voltage not exceeding the rated voltage at normal temperature and humidity and within 2 minutes of charging.													
7	Capacitance	Within the specified tolerance.	The capacitance shall be measured at 25°C with 1±0.1kHz in frequency and 1±0.2Vr.m.s. in voltage.													
8	Dissipation Factor (D.F.)	X7R : 0.035 max. Y5V : 0.09 max. (for 16V) : 0.125 max. (for 10V)	D.F. shall be measured under the same conditions at the capacitance.													
9	Capacitance Temperature Characteristics	<table border="1"> <thead> <tr> <th>Char.</th> <th>Temp. Range</th> <th>Reference Temp.</th> <th>Cap. Change Rate</th> </tr> </thead> <tbody> <tr> <td>X7R</td> <td>-55 to +125°C</td> <td>25°C</td> <td>Within±15%</td> </tr> <tr> <td>Y5V</td> <td>-30 to +85°C</td> <td>25°C</td> <td>Within±22%</td> </tr> </tbody> </table>	Char.	Temp. Range	Reference Temp.	Cap. Change Rate	X7R	-55 to +125°C	25°C	Within±15%	Y5V	-30 to +85°C	25°C	Within±22%	The range of capacitance change in reference to 25°C within the temperature range shown in the table shall be within the specified ranges. The capacitance change shall be measured after 5 min. at each specified temperature stage.	
Char.	Temp. Range	Reference Temp.	Cap. Change Rate													
X7R	-55 to +125°C	25°C	Within±15%													
Y5V	-30 to +85°C	25°C	Within±22%													
10	Mechanical Strength	Bond Strength	MIL-STD-883 Method 2011 Condition D Mount the capacitor on a gold metallized alumina substrate with Au-Sn (80/20) and bond a 20μm (0.0008 inch) gold wire to the capacitor terminal using an ultrasonic wedge bond. Then, pull wire.													
		Die Shear Strength		MIL-STD-883 Method 2019 Mount the capacitor on a gold metallized alumina substrate with Au-Sn (80/20). Apply the force parallel to the substrate.												
11	Vibration Resistance	Appearance	Ramp frequency from 10 to 55Hz then return to 10Hz all within 1 minute. Amplitude : 1.5 mm (0.06 inch) max. total excursion. Apply this motion for a period of 2 hours in each of 3 mutually perpendicular directions (total 6 hours).													
		Capacitance														
		D.F.														
12	Temperature Cycle	The measured values shall satisfy the values in the following table.														
		<table border="1"> <thead> <tr> <th>Item</th> <th>Specification</th> </tr> </thead> <tbody> <tr> <td>Appearance</td> <td>No marked defect</td> </tr> <tr> <td>Capacitance Change</td> <td>X7R ..... Within±7.5% Y5V ..... Within±20%</td> </tr> <tr> <td>I.R.</td> <td>More than 10,000MΩ</td> </tr> <tr> <td>D.F.</td> <td>X7R ..... 0.035 max. Y5V ..... 0.09 max.(for 16V) : 0.125 max.(for 10V)</td> </tr> <tr> <td>Dielectric Strength</td> <td>No failure</td> </tr> </tbody> </table>		Item	Specification	Appearance	No marked defect	Capacitance Change	X7R ..... Within±7.5% Y5V ..... Within±20%	I.R.	More than 10,000MΩ	D.F.	X7R ..... 0.035 max. Y5V ..... 0.09 max.(for 16V) : 0.125 max.(for 10V)	Dielectric Strength	No failure	
		Item	Specification													
		Appearance	No marked defect													
		Capacitance Change	X7R ..... Within±7.5% Y5V ..... Within±20%													
		I.R.	More than 10,000MΩ													
D.F.	X7R ..... 0.035 max. Y5V ..... 0.09 max.(for 16V) : 0.125 max.(for 10V)															
Dielectric Strength	No failure															
The capacitor shall be set for 48±4 hours at room temperature after one hour heat of treatment at 150±9°C, then measure for the initial measurement. Fix the capacitor to the supporting jig in the same manner and under the same conditions as (11) and conduct the five cycles according to the temperatures and time shown in the following table. Set it for 48±4 hours at room temperature, then measure.																
<table border="1"> <thead> <tr> <th>Step</th> <th>1</th> <th>2</th> <th>3</th> <th>4</th> </tr> </thead> <tbody> <tr> <td>Temp.(°C)</td> <td>Min. Operating Temp. <math>\pm 3</math></td> <td>Room Temp.</td> <td>Max. Operating Temp. <math>\pm 3</math></td> <td>Room Temp.</td> </tr> <tr> <td>Time(min.)</td> <td>30±3</td> <td>2 to 3</td> <td>30±3</td> <td>2 to 3</td> </tr> </tbody> </table>		Step	1	2	3	4	Temp.(°C)	Min. Operating Temp. $\pm 3$	Room Temp.	Max. Operating Temp. $\pm 3$	Room Temp.	Time(min.)	30±3	2 to 3	30±3	2 to 3
Step	1	2	3	4												
Temp.(°C)	Min. Operating Temp. $\pm 3$	Room Temp.	Max. Operating Temp. $\pm 3$	Room Temp.												
Time(min.)	30±3	2 to 3	30±3	2 to 3												
The measured values shall satisfy the values in the following table.																
<table border="1"> <thead> <tr> <th>Item</th> <th>Specification</th> </tr> </thead> <tbody> <tr> <td>Appearance</td> <td>No marked defect</td> </tr> <tr> <td>Capacitance Change</td> <td>X7R ..... Within±12.5% Y5V ..... Within±30%</td> </tr> <tr> <td>I.R.</td> <td>More than 1,000MΩ</td> </tr> <tr> <td>D.F.</td> <td>X7R ..... 0.05 max. Y5V ..... 0.125 max.(for 16V) : 0.15 max.(for 10V)</td> </tr> <tr> <td>Dielectric Strength</td> <td>No failure</td> </tr> </tbody> </table>		Item	Specification	Appearance	No marked defect	Capacitance Change	X7R ..... Within±12.5% Y5V ..... Within±30%	I.R.	More than 1,000MΩ	D.F.	X7R ..... 0.05 max. Y5V ..... 0.125 max.(for 16V) : 0.15 max.(for 10V)	Dielectric Strength	No failure			
Item	Specification															
Appearance	No marked defect															
Capacitance Change	X7R ..... Within±12.5% Y5V ..... Within±30%															
I.R.	More than 1,000MΩ															
D.F.	X7R ..... 0.05 max. Y5V ..... 0.125 max.(for 16V) : 0.15 max.(for 10V)															
Dielectric Strength	No failure															
13	Humidity (Steady State)	The measured values shall satisfy the values in the following table.														
		<table border="1"> <thead> <tr> <th>Item</th> <th>Specification</th> </tr> </thead> <tbody> <tr> <td>Appearance</td> <td>No marked defect</td> </tr> <tr> <td>Capacitance Change</td> <td>X7R ..... Within±12.5% Y5V ..... Within±30%</td> </tr> <tr> <td>I.R.</td> <td>More than 1,000MΩ</td> </tr> <tr> <td>D.F.</td> <td>X7R ..... 0.05 max. Y5V ..... 0.125 max.(for 16V) : 0.15 max.(for 10V)</td> </tr> <tr> <td>Dielectric Strength</td> <td>No failure</td> </tr> </tbody> </table>		Item	Specification	Appearance	No marked defect	Capacitance Change	X7R ..... Within±12.5% Y5V ..... Within±30%	I.R.	More than 1,000MΩ	D.F.	X7R ..... 0.05 max. Y5V ..... 0.125 max.(for 16V) : 0.15 max.(for 10V)	Dielectric Strength	No failure	
Item	Specification															
Appearance	No marked defect															
Capacitance Change	X7R ..... Within±12.5% Y5V ..... Within±30%															
I.R.	More than 1,000MΩ															
D.F.	X7R ..... 0.05 max. Y5V ..... 0.125 max.(for 16V) : 0.15 max.(for 10V)															
Dielectric Strength	No failure															
		Set the capacitor for 500±12 hours at 40±20°C, in 90 to 95% humidity. Take it out and set it for 48±4 hours at room temperature, then measure.														

Continued on the following page. 

## Specifications and Test Methods

 Continued from the preceding page.

No.	Item	Specification	Test Method												
14	Humidity Load	<p>The measured values shall satisfy the values in the following table.</p> <table border="1"> <thead> <tr> <th>Item</th> <th>Specification</th> </tr> </thead> <tbody> <tr> <td>Appearance</td> <td>No marked defect</td> </tr> <tr> <td>Capacitance Change</td> <td>X7R ..... Within <math>\pm 12.5\%</math> Y5V ..... Within <math>\pm 38\%</math></td> </tr> <tr> <td>I.R.</td> <td>More than 500M<math>\Omega</math></td> </tr> <tr> <td>D.F.</td> <td>X7R ..... 0.05 max. Y5V ..... 0.125 max.(for 16V) 0.15 max.(for 10V)</td> </tr> <tr> <td>Dielectric Strength</td> <td>No failure</td> </tr> </tbody> </table>	Item	Specification	Appearance	No marked defect	Capacitance Change	X7R ..... Within $\pm 12.5\%$ Y5V ..... Within $\pm 38\%$	I.R.	More than 500M $\Omega$	D.F.	X7R ..... 0.05 max. Y5V ..... 0.125 max.(for 16V) 0.15 max.(for 10V)	Dielectric Strength	No failure	<p>Apply the rated voltage for 500<math>\pm</math>12 hours at 40<math>\pm</math>20<math>^{\circ}</math>C, in 90 to 95% humidity and set it for 48<math>\pm</math>4 hours at room temperature, then measure. The charge/discharge current is less than 50mA.</p> <p>• Initial measurement for Y5V Perform a heat treatment at 150<math>\pm</math>9<math>^{\circ}</math>C for one hour and then let sit for 48<math>\pm</math>4 hours at room temperature. Perform the initial measurement.</p>
Item	Specification														
Appearance	No marked defect														
Capacitance Change	X7R ..... Within $\pm 12.5\%$ Y5V ..... Within $\pm 38\%$														
I.R.	More than 500M $\Omega$														
D.F.	X7R ..... 0.05 max. Y5V ..... 0.125 max.(for 16V) 0.15 max.(for 10V)														
Dielectric Strength	No failure														
15	High Temperature Load	<p>The measured values shall satisfy the values in the following table.</p> <table border="1"> <thead> <tr> <th>Item</th> <th>Specification</th> </tr> </thead> <tbody> <tr> <td>Appearance</td> <td>No marked defect</td> </tr> <tr> <td>Capacitance Change</td> <td>X7R ..... Within <math>\pm 12.5\%</math> Y5V ..... Within <math>\pm 38\%</math></td> </tr> <tr> <td>I.R.</td> <td>More than 1,000M<math>\Omega</math></td> </tr> <tr> <td>D.F.</td> <td>X7R ..... 0.05 max. Y5V ..... 0.125 max.(for 16V) 0.15 max.(for 10V)</td> </tr> <tr> <td>Dielectric Strength</td> <td>No failure</td> </tr> </tbody> </table>	Item	Specification	Appearance	No marked defect	Capacitance Change	X7R ..... Within $\pm 12.5\%$ Y5V ..... Within $\pm 38\%$	I.R.	More than 1,000M $\Omega$	D.F.	X7R ..... 0.05 max. Y5V ..... 0.125 max.(for 16V) 0.15 max.(for 10V)	Dielectric Strength	No failure	<p>A voltage treatment shall be given to the capacitor, in which a DC voltage of 200% the rated voltage is applied for one hour at the maximum operating temperature <math>\pm 3^{\circ}</math>C then it shall be set for 48<math>\pm</math>4 hours at room temperature and the initial measurement shall be conducted.</p> <p>Then apply the above mentioned voltage continuously for 1000<math>\pm</math>12 hours at the same temperature, remove it from the bath, and set it for 48<math>\pm</math>4 hours at room temperature, then measure. The charge/discharge current is less than 50mA.</p>
Item	Specification														
Appearance	No marked defect														
Capacitance Change	X7R ..... Within $\pm 12.5\%$ Y5V ..... Within $\pm 38\%$														
I.R.	More than 1,000M $\Omega$														
D.F.	X7R ..... 0.05 max. Y5V ..... 0.125 max.(for 16V) 0.15 max.(for 10V)														
Dielectric Strength	No failure														

Mounting for testing : The capacitors shall be mounted on the substrate as shown below using die bonding and wire bonding when tests No. 11 to 15 are performed.

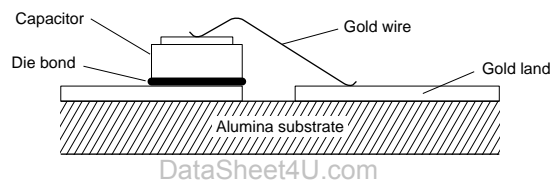
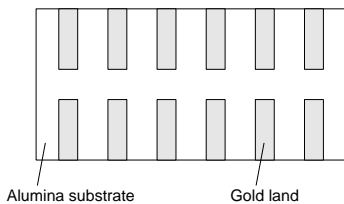

# CHIP MONOLITHIC CERAMIC CAPACITOR



## Capacitor Arrays GNM Series

### ■ Features

1. High density mounting due to mounting space saving.
2. Mounting cost saving.

### ■ Application

General electronic equipment

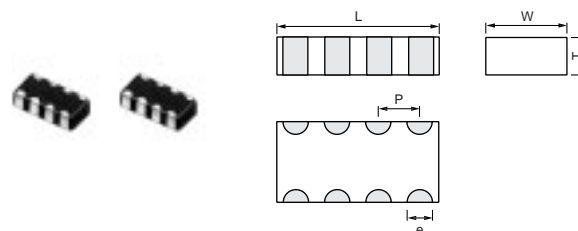

Part Number	Dimensions (mm)				
	L	W	T	P	e
<b>GNM30-401</b>	3.2 ±0.15	1.6 ±0.15	0.8 ±0.1	0.8 ±0.1	0.4 ±0.15

### Temperature Compensating Type

Part Number	<b>GNM30-401</b>	
L x W(mm)	3.2x1.6	
TC Code	C0G	
Rated Volt.(Vdc)	50	100
Capacitance and T(mm)		
10pF	0.8	0.8
11pF	0.8	0.8
12pF	0.8	0.8
13pF	0.8	0.8
15pF	0.8	0.8
16pF	0.8	0.8
18pF	0.8	0.8
20pF	0.8	0.8
22pF	0.8	0.8
24pF	0.8	0.8
27pF	0.8	0.8
30pF	0.8	0.8
33pF	0.8	0.8
36pF	0.8	0.8
39pF	0.8	0.8
43pF	0.8	0.8
47pF	0.8	0.8
51pF	0.8	0.8
56pF	0.8	0.8
62pF	0.8	0.8
68pF	0.8	0.8
75pF	0.8	0.8
82pF	0.8	0.8
91pF	0.8	0.8
100pF	0.8	0.8
110pF	0.8	0.8
120pF	0.8	0.8
130pF	0.8	0.8
150pF	0.8	0.8
160pF	0.8	0.8
180pF	0.8	0.8
200pF	0.8	0.8
220pF	0.8	0.8

 Continued from the preceding page.

Part Number	<b>GNM30-401</b>	
L x W(mm)	3.2x1.6	
TC Code	COG	
Rated Volt.(Vdc)	50	100
<b>Capacitance and T(mm)</b>		
240pF	0.8	
270pF	0.8	
300pF	0.8	
330pF	0.8	
360pF	0.8	

### High Dielectric Constant Type

Part Number	<b>GNM30-401</b>						
L x W(mm)	3.2x1.6						
TC Code	X7R				Y5V		
Rated Volt.(Vdc)	16	25	50	100	16	50	100
<b>Capacitance and T(mm)</b>							
220pF				0.8			
240pF				0.8			
270pF				0.8			
300pF				0.8			
330pF				0.8			
360pF				0.8			
390pF			0.8	0.8			
470pF			0.8	0.8			
560pF			0.8	0.8			
680pF			0.8	0.8			
820pF			0.8	0.8			
1000pF			0.8	0.8			
1200pF			0.8	0.8			
1500pF			0.8	0.8			
1800pF			0.8	0.8			
2200pF			0.8	0.8			0.8
2700pF			0.8	0.8			
3300pF			0.8	0.8			0.8
3900pF			0.8	0.8			
4700pF			0.8	0.8			0.8
5600pF			0.8				
6800pF			0.8				
8200pF			0.8				
10000pF			0.8				
12000pF			0.8				
15000pF			0.8				
18000pF		0.8					
22000pF	0.8					0.8	
27000pF	0.8						
33000pF	0.8					0.8	
39000pF	0.8						
47000pF						0.8	
68000pF					0.8		
100000pF					0.8		
150000pF					0.8		

## Specifications and Test Methods



No.	Item	Specification		Test Method																							
		Temperature Compensating Type	High Dielectric Constant Type																								
1	Operating Temperature	C0G : -55 to +125°C	X7R : -55 to +125°C Y5V : -30 to +85°C																								
2	Rated Voltage	See the previous page.		The rated voltage is defined as the maximum voltage which may be applied continuously to the capacitor. When AC voltage is superimposed on DC voltage, $V^{P-P}$ or $V^{O-P}$ , whichever is larger, shall be maintained within the rated voltage range.																							
3	Appearance	No defects or abnormalities.		Visual inspection.																							
4	Dimensions	Within the specified dimension.		Using calipers.																							
5	Dielectric Strength	No defects or abnormalities.		No failure shall be observed when 300% of the rated voltage (C0G) or 250% of the rated voltage (X7R and Y5V) is applied between the terminations for 1 to 5 seconds, provided the charge/discharge current is less than 50mA.																							
6	Insulation Resistance (I.R.)	More than 10,000MΩ or 500Ω • F (Whichever is smaller)		The insulation resistance shall be measured with a DC voltage not exceeding the rated voltage at 25°C and 75%RH max. and within 2 minutes of charging.																							
7	Capacitance	Within the specified tolerance.		The capacitance/Q/D.F. shall be measured at 25°C at the frequency and voltage shown in the table.																							
8	Q/Dissipation Factor (D.F.)	30pF min. : $Q \geq 1,000$ 30pF max. : $Q \geq 400+20C$ C : Nominal Capacitance (pF)	<table border="1"> <thead> <tr> <th>Char.</th> <th>25V min.</th> <th>16V</th> </tr> </thead> <tbody> <tr> <td>X7R</td> <td>0.025 max.</td> <td>0.035 max.</td> </tr> <tr> <td>Y5V</td> <td>0.05 max.</td> <td>0.07 max.</td> </tr> </tbody> </table>	Char.	25V min.	16V	X7R	0.025 max.	0.035 max.	Y5V	0.05 max.	0.07 max.	<table border="1"> <thead> <tr> <th>Item</th> <th>Char.</th> <th>C0G</th> <th>X7R, Y5V</th> </tr> </thead> <tbody> <tr> <td>Frequency</td> <td></td> <td>1±0.1MHz</td> <td>1±0.1MHz</td> </tr> <tr> <td>Voltage</td> <td></td> <td>0.5 to 5Vr.m.s.</td> <td>1±0.2Vr.m.s.</td> </tr> </tbody> </table>	Item	Char.	C0G	X7R, Y5V	Frequency		1±0.1MHz	1±0.1MHz	Voltage		0.5 to 5Vr.m.s.	1±0.2Vr.m.s.		
			Char.	25V min.	16V																						
X7R	0.025 max.	0.035 max.																									
Y5V	0.05 max.	0.07 max.																									
Item	Char.	C0G	X7R, Y5V																								
Frequency		1±0.1MHz	1±0.1MHz																								
Voltage		0.5 to 5Vr.m.s.	1±0.2Vr.m.s.																								
9	Capacitance Temperature Characteristics	<table border="1"> <thead> <tr> <th>Char.</th> <th>Temp. Range.</th> <th>Reference Temp.</th> <th>Cap. Change</th> </tr> </thead> <tbody> <tr> <td>X7R</td> <td>-55to +125°C</td> <td>25°C</td> <td>Within±15%</td> </tr> <tr> <td>Y5V</td> <td>-30to +85°C</td> <td></td> <td>Within±22%</td> </tr> </tbody> </table>	Char.	Temp. Range.	Reference Temp.	Cap. Change	X7R	-55to +125°C	25°C	Within±15%	Y5V	-30to +85°C		Within±22%	<p>The capacitance change shall be measured after 5 min. at each specified temperature stage.</p> <p>(1) Temperature Compensating Type</p> <p>The temperature coefficient is determined using the capacitance measured in step 3 as a reference. When cycling the temperature sequentially from step 1 through 5, the capacitance shall be within the specified tolerance for the temperature coefficient and capacitance change as Table A.</p> <p>The capacitance drift is calculated by dividing the differences between the maximum and minimum measured values in the step 1, 3 and 5 by the cap. value in step 3.</p> <table border="1"> <thead> <tr> <th>Step</th> <th>Temperature(°C)</th> </tr> </thead> <tbody> <tr> <td>1</td> <td>25±2</td> </tr> <tr> <td>2</td> <td>-55±3</td> </tr> <tr> <td>3</td> <td>25±2</td> </tr> <tr> <td>4</td> <td>125±3</td> </tr> <tr> <td>5</td> <td>25±2</td> </tr> </tbody> </table> <p>(2) High Dielectric Constant Type</p> <p>The ranges of capacitance change compared with the 25°C value over the temperature ranges shown in the table shall be within the specified ranges.</p>	Step	Temperature(°C)	1	25±2	2	-55±3	3	25±2	4	125±3	5	25±2
Char.	Temp. Range.	Reference Temp.	Cap. Change																								
X7R	-55to +125°C	25°C	Within±15%																								
Y5V	-30to +85°C		Within±22%																								
Step	Temperature(°C)																										
1	25±2																										
2	-55±3																										
3	25±2																										
4	125±3																										
5	25±2																										
10	Adhesive Strength of Termination	No removal of the terminations or other defects shall occur.		<p>Solder the capacitor to the test jig (glass epoxy board) shown in Fig.1 using a eutectic solder. Then apply 5N force in parallel with the test jig for 10±1 sec.</p> <p>The soldering shall be done either with an iron or using the reflow method and shall be conducted with care so that the soldering is uniform and free of defects such as heat shock.</p>  <table border="1"> <thead> <tr> <th>Type</th> <th>a</th> <th>b</th> <th>c</th> <th>d</th> </tr> </thead> <tbody> <tr> <td>GNM30-401</td> <td>0.8</td> <td>2.5</td> <td>0.4</td> <td>0.8</td> </tr> </tbody> </table> <p>(in mm)</p>	Type	a	b	c	d	GNM30-401	0.8	2.5	0.4	0.8													
Type	a	b	c	d																							
GNM30-401	0.8	2.5	0.4	0.8																							

Fig.1

## Specifications and Test Methods

Continued from the preceding page.

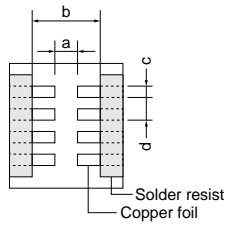
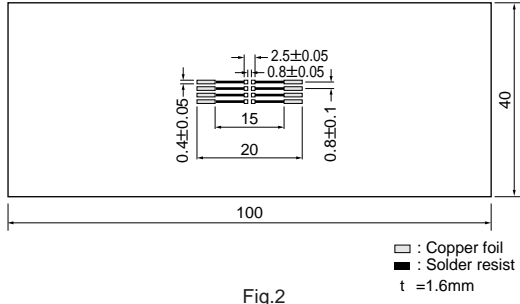
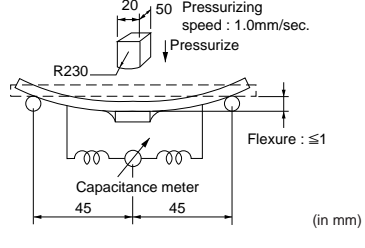
No.	Item	Specification			Test Method															
		Temperature Compensating Type	High Dielectric Constant Type																	
11	Vibration Resistance	Appearance	No defects or abnormalities.			Solder the capacitor to the test jig (glass epoxy board) in the same manner and under the same conditions as (10). The capacitor shall be subjected to a simple harmonic motion having a total amplitude of 1.5mm, the frequency being varied uniformly between the approximate limits of 10 and 55Hz. The frequency range, from 10 to 55Hz and return to 10Hz, shall be traversed in approximately 1 minute. This motion shall be applied for a period of 2 hours in each 3 mutually perpendicular directions (total of 6 hours).														
		Capacitance	Within the specified tolerance.																	
	Q/D.F.	30pF min. : $Q \geq 1000$ 30pF max. : $Q \geq 400+20C$ C : Nominal Capacitance (pF)	Char.	25V min.	16V															
			X7R	0.025 max.	0.035 max.															
			Y5V	0.05 max.	0.07 max.															
12	Deflection	No cracking or marking defects shall occur.			Solder the capacitor to the test jig (glass epoxy boards) shown in Fig.2 using a eutectic solder. Then apply a force in the direction shown in Fig.3. The soldering shall be done either with an iron or using the reflow method and shall be conducted with care so that the soldering is uniform and free of defects such as heat shock.															
																				
13	Solderability of Termination	75% of the terminations is to be soldered evenly and continuously.			Immerse the capacitor in a solution of ethanol (JIS-K-8101) and rosin (JIS-K-5902) (25% rosin in weight proportion). Preheat at 80 to 120°C for 10 to 30 seconds. After preheating, immerse in eutectic solder solution for 2±0.5 seconds at 230±5°C.															
14	Resistance to Soldering Heat	The measured and observed characteristics shall satisfy the specifications in the following table.			Preheat the capacitor at 120 to 150°C for 1 minute. Immerse the capacitor in a eutectic solder solution at 270±5°C for 10±0.5 seconds. Let sit at room temperature for 24±2 hours (temperature compensating type) or 48±4 hours (high dielectric constant type), then measure.  • Initial measurement for high dielectric constant type Perform a heat treatment at 150±9.0°C for one hour and then let sit for 48±4 hours at room temperature. Perform the initial measurement.															
		Appearance	No marking defects.																	
		Capacitance Change	Within ±2.5% or ±0.25pF (Whichever is larger)	X7R		Within±7.5%														
		Q/D.F.	30pF and over : $Q \geq 1,000$ 30pF and below : $Q \geq 400+20C$ C : Nominal Capacitance (pF)	Char.		25V min.	16V													
		I.R.	More than 10,000MΩ or 500Ω • F (Whichever is smaller)																	
	Dielectric Strength	No failure																		
15	Temperature Cycle	The measured and observed characteristics shall satisfy the specifications in the following table.			Fix the capacitor to the supporting jig in the same manner and under the same conditions as (10). Perform the five cycles according to the four heat treatments listed in the following table. Let sit for 24±2 hours (temperature compensating type) or 48±4 hours (high dielectric constant type) at room temperature, then measure.  <table border="1" data-bbox="933 1668 1452 1780"> <thead> <tr> <th>Step</th> <th>1</th> <th>2</th> <th>3</th> <th>4</th> </tr> </thead> <tbody> <tr> <td>Temp.(°C)</td> <td>Min. Operating Temp. <math>\pm 3</math></td> <td>Room Temp.</td> <td>Max. Operating Temp. <math>\pm 3</math></td> <td>Room Temp.</td> </tr> <tr> <td>Time(min.)</td> <td>30±3</td> <td>2 to 3</td> <td>30±3</td> <td>2 to 3</td> </tr> </tbody> </table> • Initial measurement for high dielectric constant type Perform a heat treatment at 150±9.0°C for one hour and then let sit for 48±4 hours at room temperature. Perform the initial measurement.	Step	1	2	3	4	Temp.(°C)	Min. Operating Temp. $\pm 3$	Room Temp.	Max. Operating Temp. $\pm 3$	Room Temp.	Time(min.)	30±3	2 to 3	30±3	2 to 3
		Step	1	2		3	4													
		Temp.(°C)	Min. Operating Temp. $\pm 3$	Room Temp.		Max. Operating Temp. $\pm 3$	Room Temp.													
		Time(min.)	30±3	2 to 3		30±3	2 to 3													
		Appearance	No marking defects.																	
Capacitance Change	Within ±2.5% or ±0.25pF (Whichever is larger)	X7R	Within±7.5%																	
Q/D.F.	30pF and over : $Q \geq 1,000$ 30pF and below : $Q \geq 400+20C$ C : Nominal Capacitance (pF)	Char.	25V min.	16V																
	I.R.	More than 10,000MΩ or 500Ω • F (Whichever is smaller)																		
	Dielectric Strength	No failure																		

Continued on the following page. 



## Specifications and Test Methods

Continued from the preceding page.

No.	Item	Specification			Test Method										
		Temperature Compensating Type	High Dielectric Constant Type												
16	Humidity, Steady State	The measured and observed characteristics shall satisfy the specifications in the following table.			Sit the capacitor at 40±2°C and 90 to 95% humidity for 500±12 hours. Remove and let sit for 24±2 hours (temperature compensating type) or 48±4 hours (high dielectric constant type) at room temperature, then measure.										
		Appearance	No marking defects.												
		Capacitance Change	Within ±5% or ±0.5pF (Whichever is larger)	X7R ..... Within±12.5%		Y5V ..... Within±30%									
		Q/D.F.	30pF and over : Q≥350 10pF and over, 30pF and below : Q≥275+ $\frac{5}{3}$ C 10pF and below : Q≥200+10C C : Nominal Capacitance (pF)	<table border="1"> <thead> <tr> <th>Char.</th> <th>25V min.</th> <th>16V</th> </tr> </thead> <tbody> <tr> <td>X7R</td> <td>0.05 max.</td> <td>0.05 max.</td> </tr> <tr> <td>Y5V</td> <td>0.075 max.</td> <td>0.1 max.</td> </tr> </tbody> </table>		Char.	25V min.	16V	X7R	0.05 max.	0.05 max.	Y5V	0.075 max.	0.1 max.	
		Char.	25V min.	16V											
X7R	0.05 max.	0.05 max.													
Y5V	0.075 max.	0.1 max.													
I.R.	More than 1,000MΩ or 50Ω • F (Whichever is smaller)														
17	Humidity Load	The measured and observed characteristics shall satisfy the specifications in the following table.			Apply the rated voltage at 40±2°C and 90 to 95% humidity for 500±12 hours. Remove and let sit for 24±2 hours (temperature compensating type) or 48±4 hours (high dielectric constant type) at room temperature, then measure. The charge/discharge current is less than 50mA.										
		Appearance	No marking defects.												
		Capacitance Change	Within ±7.5% or ±0.75pF (Whichever is larger)	X7R ..... Within±12.5%		Y5V ..... Within±30%									
		Q/D.F.	30pF and over : Q≥200 30pF and below : Q≥100+ $\frac{10}{3}$ C C : Nominal Capacitance (pF)	<table border="1"> <thead> <tr> <th>Char.</th> <th>25V min.</th> <th>16V</th> </tr> </thead> <tbody> <tr> <td>X7R</td> <td>0.05 max.</td> <td>0.05 max.</td> </tr> <tr> <td>Y5V</td> <td>0.075 max.</td> <td>0.1 max.</td> </tr> </tbody> </table>		Char.	25V min.	16V	X7R	0.05 max.	0.05 max.	Y5V	0.075 max.	0.1 max.	
		Char.	25V min.	16V											
X7R	0.05 max.	0.05 max.													
Y5V	0.075 max.	0.1 max.													
I.R.	More than 500MΩ or 25Ω • F (Whichever is smaller)														
	Dielectric Strength	No failure													
18	High Temperature Load	The measured and observed characteristics shall satisfy the specifications in the following table.			Apply 200% of the rated voltage for 1,000±12 hours at the maximum operating temperature ±3°C. Let sit for 24±2 hours (temperature compensating type) or 48±4 hours (high dielectric constant type) at room temperature, then measure. The charge/discharge current is less than 50mA.  •Initial measurement for high dielectric constant type. Apply 200% of the rated DC voltage for one hour at the maximum operating temperature ±3°C. Remove and let sit for 48±4 hours at room temperature. Perform initial measurement.										
		Appearance	No marking defects.												
		Capacitance Change	Within ±3% or ±0.3pF (Whichever is larger)	X7R ..... Within±12.5%		Y5V ..... Within±30%									
		Q/D.F.	30pF and over : Q≥350 10pF and over, 30pF and below : Q≥275+ $\frac{5}{3}$ C 10pF and below : Q≥200+10C C : Nominal Capacitance (pF)	<table border="1"> <thead> <tr> <th>Char.</th> <th>25V min.</th> <th>16V</th> </tr> </thead> <tbody> <tr> <td>X7R</td> <td>0.04 max.</td> <td>0.05 max.</td> </tr> <tr> <td>Y5V</td> <td>0.075 max.</td> <td>0.1 max.</td> </tr> </tbody> </table>		Char.	25V min.	16V	X7R	0.04 max.	0.05 max.	Y5V	0.075 max.	0.1 max.	
		Char.	25V min.	16V											
X7R	0.04 max.	0.05 max.													
Y5V	0.075 max.	0.1 max.													
I.R.	More than 1,000MΩ or 50Ω • F (Whichever is smaller)														
	Dielectric Strength	No failure													

Table A

Char.	Temp. Coeff. (ppm/°C) Note 1	Capacitance Change from 25°C (%)					
		-55°C		-30°C		-10°C	
		Max.	Min.	Max.	Min.	Max.	Min.
COG	0±30	0.58	-0.24	0.40	-0.17	0.25	-0.11

Note 1 : Nominal values denote the temperature coefficient within a range of 25 to 125°C.

# CHIP MONOLITHIC CERAMIC CAPACITOR



## for Ultrasonic Sensors ZLM Type

### ■ Features

1. Proper to compensate for ultrasonic sensor.
2. Small chip size and high cap. Value.

### ■ Application

Ultrasonic sensor

(Back sonar, Corner sonar and etc.)

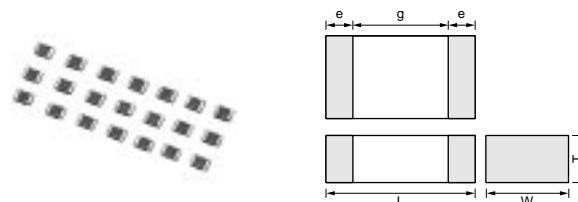

Part Number	Dimensions (mm)				
	L	W	T	e	g min.
<b>GRM40</b>	2.0 ±0.1	1.25 ±0.1	0.85 ±0.1	0.2 to 0.7	0.7

Part Number	Rated Voltage (Vdc)	TC Code	Capacitance (pF)	Length L (mm)	Width W (mm)	Thickness T (mm)
<b>GRM40ZLM102K100</b>	100	ZLM	1000 ±10%	2.0 ±0.1mm	1.25 ±0.1mm	0.85 ±0.1mm
<b>GRM40ZLM152K100</b>	100	ZLM	1500 ±10%	2.0 ±0.1mm	1.25 ±0.1mm	0.85 ±0.1mm

DataSheet4U.com

9

et4U.com

DataShee

DataSheet4U.com

www.DataSheet4U.com

## Specifications and Test Methods

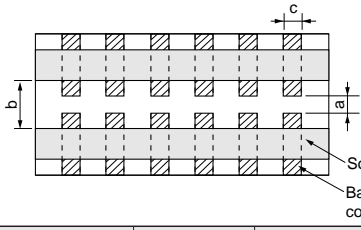
No.	Item	Specification	Test Method												
1	Operating Temperature	-25°C to +85°C													
2	Rated Voltage	See the previous pages.	The rated voltage is defined as the maximum voltage which may be applied continuously to the capacitor. When AC voltage is superimposed on DC voltage, $V^{P-P}$ or $V^{O-P}$ , whichever is larger, shall be maintained within the rated voltage range.												
3	Appearance	No defects or abnormalities.	Visual inspection.												
4	Dimensions	Within the specified dimensions.	Using calipers.												
5	Dielectric Strength	No defects or abnormalities.	No failure shall be observed when 300% of the rated voltage is applied between the terminations for 1 to 5 seconds, provided the charge/discharge current is less than 50mA.												
6	Insulation Resistance (I.R.)	More than 10,000MΩ or 500Ω • F. (Whichever is smaller)	The insulation resistance shall be measured with a DC voltage not exceeding the rated voltage at 20°C and 75%RH max. and within 2 minutes of charging.												
7	Capacitance	Within the specified tolerance.	The capacitance/D.F. shall be measured at 20°C with 1±0.1kHz in frequency and 1±0.2Vr.m.s. in voltage.												
8	Dissipation Factor (D.F.)	0.01 max.													
9	Capacitance Temperature Characteristics	Within $-4,700 \pm 1,888$ ppm/°C (at -25 to +20°C) Within $-4,700 \pm 1,888$ ppm/°C (at +20 to +85°C)	<p>The temperature coefficient is determined using the capacitance measured in step 1 as a reference. When cycling the temperature sequentially from step 1 through 5, the capacitance shall be within the specified tolerance for the temperature coefficient. The capacitance change shall be measured after 5 min. at each specified temperature stage.</p> <table border="1" style="margin-left: auto; margin-right: auto;"> <thead> <tr> <th>Step</th> <th>Temperature(°C)</th> </tr> </thead> <tbody> <tr> <td>1</td> <td>20±2</td> </tr> <tr> <td>2</td> <td>-25±3</td> </tr> <tr> <td>3</td> <td>20±2</td> </tr> <tr> <td>4</td> <td>85±3</td> </tr> <tr> <td>5</td> <td>20±2</td> </tr> </tbody> </table>	Step	Temperature(°C)	1	20±2	2	-25±3	3	20±2	4	85±3	5	20±2
Step	Temperature(°C)														
1	20±2														
2	-25±3														
3	20±2														
4	85±3														
5	20±2														
10	Adhesive Strength of Termination	No removal of the terminations or other defect shall occur.	<p>Solder the capacitor to the test jig (glass epoxy board) shown in Fig.1 using a eutectic solder. Then apply 10N force in the direction of the arrow. The soldering shall be done either with an iron or using the reflow method and shall be conducted with care so that the soldering is uniform and free of defects such as heat shock.</p>  <table border="1" style="margin-left: auto; margin-right: auto;"> <thead> <tr> <th>Type</th> <th>a</th> <th>b</th> <th>c</th> </tr> </thead> <tbody> <tr> <td>GRM40</td> <td>1.2</td> <td>4.0</td> <td>1.65</td> </tr> </tbody> </table> <p style="text-align: right;">(in mm)</p> <p style="text-align: center;">Fig.1</p>	Type	a	b	c	GRM40	1.2	4.0	1.65				
Type	a	b	c												
GRM40	1.2	4.0	1.65												
11	Vibration Resistance	Appearance	No defects or abnormalities.												
		Capacitance	Within the specified tolerance.												
		D.F.	0.01 max.												
			<p>Solder the capacitor to the test jig (glass epoxy board) in the same manner and under the same conditions as (10). The capacitor shall be subjected to a simple harmonic motion having a total amplitude of 1.5mm, the frequency being varied uniformly between the approximate limits of 10 and 55Hz. The frequency range, from 10 to 55Hz and return to 10Hz, shall be traversed in approximately 1 minute. This motion shall be applied for a period of 2 hours in each 3 mutually perpendicular directions (total of 6 hours).</p>												

Continued on the following page.

## Specifications and Test Methods

Continued from the preceding page.

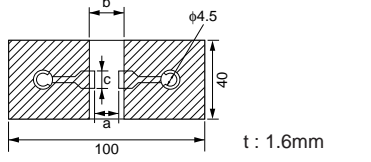
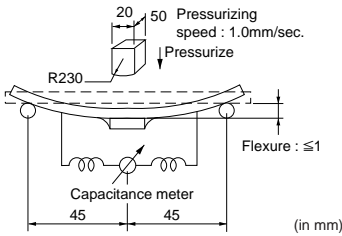
No.	Item	Specification	Test Method					
12	Deflection	No cracking or marking defects shall occur.	<p>Solder the capacitor to the test jig (glass epoxy boards) shown in Fig.2 using a eutectic solder.</p> <p>Then apply a force in the direction shown in Fig.3.</p> <p>The soldering shall be done either with an iron or using the reflow method and shall be conducted with care so that the soldering is uniform and free of defects such as heat shock.</p>					
		 <table border="1" style="margin-left: auto; margin-right: auto;"> <thead> <tr> <th>Type</th> <th>a</th> <th>b</th> <th>c</th> </tr> </thead> <tbody> <tr> <td>GRM40</td> <td>1.2</td> <td>4.0</td> <td>1.65</td> </tr> </tbody> </table> <p style="text-align: center;">(in mm)</p> <p style="text-align: center;">Fig.2</p>		Type	a	b	c	GRM40
Type	a	b	c					
GRM40	1.2	4.0	1.65					
			 <p style="text-align: center;">(in mm)</p> <p style="text-align: center;">Fig.3</p>					
13	Solderability of Termination	75% of the terminations is to be soldered evenly and continuously.	Immerse the capacitor in a solution of ethanol (JIS-K-8101) and rosin (JIS-K-5902) (25% rosin in weight proportion). Preheat at 80 to 120°C for 10 to 30 seconds. After preheating, immerse in eutectic solder solution for 2±0.5 seconds at 230±5°C.					
14	Resistance to Soldering Heat	Appearance	No defects or abnormalities.					
		Capacitance Change	Within ±7.5%					
		D.F.	0.01 max.					
		I.R.	More than 10,000MΩ or 500Ω • F (Whichever is smaller)					
		Dielectric Strength	No failure					
15	Temperature Cycle	Appearance	No defects or abnormalities.					
		Capacitance Change	Within ±7.5%					
		D.F.	0.01 max.					
		I.R.	More than 10,000MΩ or 500Ω • F (Whichever is smaller)					
		Dielectric Strength	No failure					
16	Humidity, Steady State	Appearance	No defects or abnormalities.					
		Capacitance Change	Within ±12.5%					
		D.F.	0.02 max.					
		I.R.	More than 1,000MΩ or 50Ω • F (Whichever is smaller)					
		Dielectric Strength	No failure					
17	Humidity Load	Appearance	No defects or abnormalities.					
		Capacitance Change	Within ±12.5%					
		D.F.	0.02 max.					
		I.R.	More than 500MΩ or 25Ω • F (Whichever is smaller)					
18	High Temperature Load	Appearance	No defects or abnormalities.					
		Capacitance Change	Within ±12.5%					
		D.F.	0.02 max.					
		I.R.	More than 1,000MΩ or 50Ω • F (Whichever is smaller)					

Immerse the capacitor in a solution of ethanol (JIS-K-8101) and rosin (JIS-K-5902) (25% rosin in weight proportion). Preheat at 80 to 120°C for 10 to 30 seconds. After preheating, immerse in eutectic solder solution for 2±0.5 seconds at 230±5°C.

Preheat the capacitor at 120 to 150°C for 1 minute. Immerse the capacitor in a eutectic solder solution at 270±5°C for 10±0.5 seconds. Let sit at room temperature for 24±2 hours, then measure.

Fix the capacitor to the supporting jig in the same manner and under the same conditions as (11). Perform the five cycles according to the four heat treatments listed in the following table. Let sit for 24±2 hours at room temperature, then measure.

Step	1	2	3	4
Temp.(°C)	-25 ±3	RoomTemp.	85 ±3	RoomTemp.
Time(min.)	30±3	2 to 3	30±3	2 to 3

Sit the capacitor at 40±2°C and 90 to 95% humidity for 500±12 hours. Remove and let sit for 24±2 hours at room temperature, then measure.

Apply the rated voltage at 40±2°C and 90 to 95% humidity for 500±12 hours. Remove and let sit for 24±2 hours at room temperature, then measure. The charge/discharge current is less than 50mA.

Apply 200% of the rated voltage for 1,000±12 hours at 85±3°C. Let sit for 24±2 hours at room temperature, then measure. The charge/discharge current is less than 50mA.

# CHIP MONOLITHIC CERAMIC CAPACITOR

## High-frequency for Flow/Reflow Soldering GRQ Series

### ■ Features

- 1.HiQ and low ESR at VHF, UHF, Microwave.
- 2.Feature improvement, low power consumption for mobile telecommunication (Base station, terminal, etc.)

### ■ Application

High-frequency circuit (Mobile telecommunication, etc.)

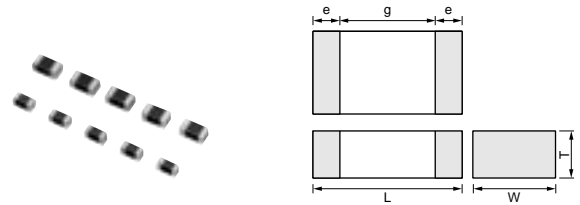

Part Number	Dimensions (mm)				
	L	W	T	e	g min.
<b>GRQ706</b>	1.6 ±0.1	0.8 ±0.1	0.8 ±0.1	0.2 to 0.5	0.5
<b>GRQ708</b>	2.0 ±0.1	1.25 ±0.1	0.85 ±0.1	0.2 to 0.7	0.7

Part Number	GRQ706		GRQ708	
L x W(mm)	1.60x0.80		2.00x1.25	
TC Code	COG		COG	
Rated Volt.(Vdc)	50	100	50	100
Capacitance and T(mm)				
0.5pF		0.80		0.85
0.75pF		0.80		0.85
1.0pF		0.80		0.85
1.1pF		0.80		0.85
1.2pF		0.80		0.85
1.3pF		0.80		0.85
1.5pF		0.80		0.85
1.6pF		0.80		0.85
1.8pF		0.80		0.85
2.0pF		0.80		0.85
2.2pF		0.80		0.85
2.4pF		0.80		0.85
2.7pF		0.80		0.85
3.0pF		0.80		0.85
3.3pF		0.80		0.85
3.6pF		0.80		0.85
3.9pF		0.80		0.85
4.0pF		0.80		0.85
4.3pF		0.80		0.85
4.7pF		0.80		0.85
5.0pF		0.80		0.85
5.1pF		0.80		0.85
5.6pF		0.80		0.85
6.0pF		0.80		0.85
6.2pF		0.80		0.85
6.8pF		0.80		0.85
7.0pF	0.80			0.85
7.5pF	0.80			0.85
8.0pF	0.80			0.85
8.2pF	0.80			0.85
9.0pF	0.80			0.85
9.1pF	0.80			0.85
10.0pF	0.80			0.85
11pF	0.80			0.85
12pF	0.80			0.85

Continued on the following page.

 Continued from the preceding page.

Part Number	GRQ706		GRQ708	
L x W(mm)	1.60x0.80		2.00x1.25	
TC Code	COG		COG	
Rated Volt.(Vdc)	50	100	50	100
<b>Capacitance and T(mm)</b>				
13pF	0.80			0.85
15pF	0.80			0.85
16pF	0.80			0.85
18pF	0.80			0.85
20pF	0.80		0.85	
22pF	0.80		0.85	
24pF	0.80		0.85	
27pF			0.85	
30pF			0.85	
33pF			0.85	
36pF			0.85	
39pF			0.85	
43pF			0.85	
47pF			0.85	

### ■ Q-Frequency Characteristics

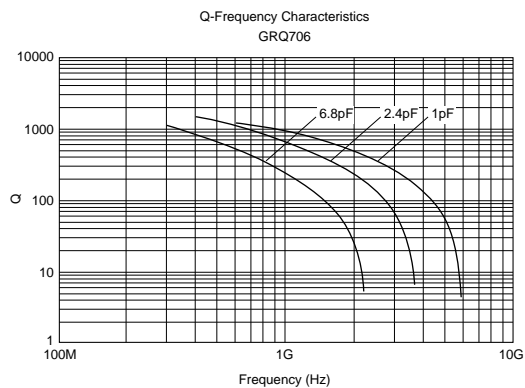

### ■ Resonant Frequency-Capacitance

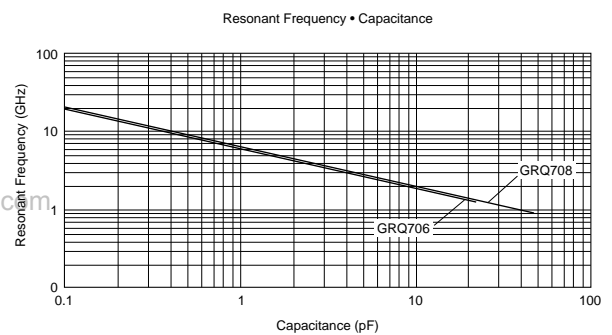

## Specifications and Test Methods

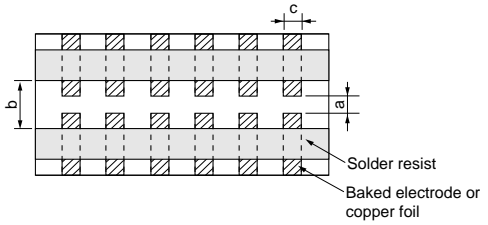
No.	Item	Specification	Test Method												
1	Operating Temperature Range	COG : -55°C to 125°C													
2	Rated Voltage	See the previous pages.	The rated voltage is defined as the maximum voltage which may be applied continuously to the capacitor. When AC voltage is superimposed on DC voltage, $V^{P-P}$ or $V^{O-P}$ , whichever is larger, shall be maintained within the rated voltage range.												
3	Appearance	No defects or abnormalities.	Visual inspection.												
4	Dimensions	Within the specified dimensions.	Using calipers.												
5	Dielectric Strength	No defects or abnormalities.	No failure shall be observed when 300% of the rated voltage is applied between the terminations for 1 to 5 seconds, provided the charge/discharge current is less than 50mA.												
6	Insulation Resistance (I.R.)	More than 10,000MΩ or 500Ω • F. (Whichever is smaller)	The insulation resistance shall be measured with a DC voltage not exceeding the rated voltage at 25°C and 75%RH max. and within 2 minutes of charging.												
7	Capacitance	Within the specified tolerance.	The capacitance/Q shall be measured at 25°C at the frequency and voltage shown in the table.												
8	Q	$Q \geq 1000$	<table border="1" style="width: 100%; border-collapse: collapse;"> <thead> <tr> <th>Item</th> <th>Char.</th> <th>COG(1000pF and below)</th> </tr> </thead> <tbody> <tr> <td>Frequency</td> <td></td> <td>1±0.1MHz</td> </tr> <tr> <td>Voltage</td> <td></td> <td>0.5 to 5Vrms</td> </tr> </tbody> </table>	Item	Char.	COG(1000pF and below)	Frequency		1±0.1MHz	Voltage		0.5 to 5Vrms			
Item	Char.	COG(1000pF and below)													
Frequency		1±0.1MHz													
Voltage		0.5 to 5Vrms													
9	Capacitance Temperature Characteristics	Capacitance Change	Within the specified tolerance. (Table A-1)												
		Temperature Coefficient	Within the specified tolerance. (Table A-1)												
		Capacitance Drift	Within ±0.2% or ±0.05pF (Whichever is larger.)												
			<p>The temperature coefficient is determined using the capacitance measured in step 3 as a reference.</p> <p>When cycling the temperature sequentially from step 1 through 5, the capacitance shall be within the specified tolerance for the temperature coefficient and capacitance change as Table A.</p> <p>The capacitance drift is calculated by dividing the differences between the maximum and minimum measured values in the step 1, 3 and 5 by the cap. value in step 3.</p> <table border="1" style="width: 100%; border-collapse: collapse;"> <thead> <tr> <th>Step</th> <th>Temperature(°C)</th> </tr> </thead> <tbody> <tr> <td>1</td> <td>25±2</td> </tr> <tr> <td>2</td> <td>-55±3</td> </tr> <tr> <td>3</td> <td>25±2</td> </tr> <tr> <td>4</td> <td>125±3</td> </tr> <tr> <td>5</td> <td>25±2</td> </tr> </tbody> </table>	Step	Temperature(°C)	1	25±2	2	-55±3	3	25±2	4	125±3	5	25±2
Step	Temperature(°C)														
1	25±2														
2	-55±3														
3	25±2														
4	125±3														
5	25±2														
10	Adhesive Strength of Termination	No removal of the terminations or other defect shall occur.	<p>Solder the capacitor to the test jig (glass epoxy board) shown in Fig.1 using a eutectic solder. Then apply 10N* force in parallel with the test jig for 10±1sec.</p> <p>The soldering shall be done either with an iron or using the reflow method and shall be conducted with care so that the soldering is uniform and free of defects such as heat shock.</p> <p style="text-align: right;">*5N (GRQ706)</p> <div style="text-align: center;">  <p style="text-align: right;">Solder resist Baked electrode or copper foil</p> <table border="1" style="width: 100%; border-collapse: collapse;"> <thead> <tr> <th>Type</th> <th>a</th> <th>b</th> <th>c</th> </tr> </thead> <tbody> <tr> <td>GRQ706</td> <td>1.0</td> <td>3.0</td> <td>1.2</td> </tr> <tr> <td>GRQ708</td> <td>1.2</td> <td>4.0</td> <td>1.65</td> </tr> </tbody> </table> <p style="text-align: right;">(in mm)</p> </div> <p style="text-align: center;">Fig.1</p>	Type	a	b	c	GRQ706	1.0	3.0	1.2	GRQ708	1.2	4.0	1.65
Type	a	b	c												
GRQ706	1.0	3.0	1.2												
GRQ708	1.2	4.0	1.65												
11	Vibration Resistance	Appearance	No defects or abnormalities.												
		Capacitance	Within the specified tolerance.												
		Q	$Q \geq 1000$												
			<p>Solder the capacitor to the test jig (glass epoxy board) in the same manner and under the same conditions as (10).</p> <p>The capacitor shall be subjected to a simple harmonic motion having a total amplitude of 1.5mm, the frequency being varied uniformly between the approximate limits of 10 and 55Hz. The frequency range, from 10 to 55Hz and return to 10Hz, shall be traversed in approximately 1 minute. This motion shall be applied for a period of 2 hours in each 3 mutually perpendicular directions (total of 6 hours).</p>												

10

et4U.com

DataShee

## Specifications and Test Methods

Continued from the preceding page.

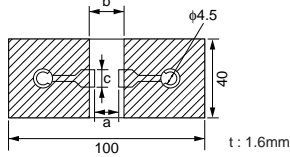
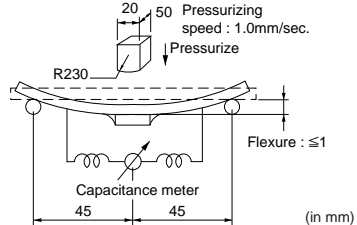
No.	Item	Specification	Test Method															
12	Deflection	No cracking or marking defects shall occur.	<p>Solder the capacitor to the test jig (glass epoxy board) shown in Fig.2 using a eutectic solder. Then apply a force in the direction shown in Fig.3. The soldering shall be done either with an iron or using the reflow method and shall be conducted with care so that the soldering is uniform and free of defects such as heat shock.</p>  <table border="1" style="margin: 10px auto;"> <thead> <tr> <th>Type</th> <th>a</th> <th>b</th> <th>c</th> </tr> </thead> <tbody> <tr> <td>GRQ706</td> <td>1.0</td> <td>3.0</td> <td>1.2</td> </tr> <tr> <td>GRQ708</td> <td>1.2</td> <td>4.0</td> <td>1.65</td> </tr> </tbody> </table> <p style="text-align: right;">(in mm)</p>	Type	a	b	c	GRQ706	1.0	3.0	1.2	GRQ708	1.2	4.0	1.65			
		Type		a	b	c												
GRQ706	1.0	3.0	1.2															
GRQ708	1.2	4.0	1.65															
		 <p style="text-align: right;">(in mm)</p>																
13	Solderability of Termination	75% of the terminations is to be soldered evenly and continuously.	Immerse the capacitor in a solution of ethanol (JIS-K-8101) and rosin (JIS-K-5902) (25% rosin in weight proportion). Preheat at 80 to 120°C for 10 to 30 seconds. After preheating, immerse in eutectic solder solution for 2±0.5 seconds at 230±5°C.															
14	Resistance to Soldering Heat	The measured and observed characteristics shall satisfy the specifications in the following table.	Preheat the capacitor at 120 to 150°C for 1 minute. Immerse the capacitor in a eutectic solder solution at 270±5°C for 10±0.5 seconds. Let sit at room temperature for 24±2 hours.															
		Appearance		No marking defects.														
		Capacitance Change		Within ±2.5% or ±0.25pF (Whichever is larger)														
		Q		Q≥1000														
		I.R.		More than 10,000MΩ or 500Ω • F (Whichever is smaller)														
	Dielectric Strength	No failure																
15	Temperature Cycle	The measured and observed characteristics shall satisfy the specifications in the following table.	Fix the capacitor to the supporting jig in the same manner and under the same conditions as (10). Perform the five cycles according to the four heat treatments listed in the following table. Let sit for 24±2 hours at room temperature, then measure. <table border="1" style="margin: 10px auto;"> <thead> <tr> <th>Step</th> <th>1</th> <th>2</th> <th>3</th> <th>4</th> </tr> </thead> <tbody> <tr> <td>Temp.(°C)</td> <td>Min. Operating Temp.+0/-3</td> <td>Room Temp.</td> <td>Max. Operating Temp.+3/-0</td> <td>Room Temp.</td> </tr> <tr> <td>Time(min.)</td> <td>30±3</td> <td>2 to 3</td> <td>30±3</td> <td>2 to 3</td> </tr> </tbody> </table>	Step	1	2	3	4	Temp.(°C)	Min. Operating Temp.+0/-3	Room Temp.	Max. Operating Temp.+3/-0	Room Temp.	Time(min.)	30±3	2 to 3	30±3	2 to 3
		Step		1	2	3	4											
		Temp.(°C)		Min. Operating Temp.+0/-3	Room Temp.	Max. Operating Temp.+3/-0	Room Temp.											
		Time(min.)		30±3	2 to 3	30±3	2 to 3											
		Appearance		No marking defects.														
Capacitance Change	Within ±2.5% or ±0.25pF (Whichever is larger)																	
Q	Q≥1000																	
I.R.	More than 10,000MΩ or 500Ω • F (Whichever is smaller)																	
	Dielectric Strength	No failure																
16	Humidity, Steady State	The measured and observed characteristics shall satisfy the specifications in the following table.	Sit the capacitor at 40±2°C and 90 to 95% humidity for 500±12 hours. Remove and let sit for 24±2 hours (temperature compensating type) at room temperature, then measure.															
		Appearance		No marking defects.														
		Capacitance Change		Within ±5% or ±0.5pF (Whichever is larger)														
		Q		Q≥350														
		I.R.		More than 1,000MΩ or 50Ω • F (Whichever is smaller)														
	Dielectric Strength	No failure																
17	Humidity Load	The measured and observed characteristics shall satisfy the specifications in the following table.	Apply the rated voltage at 40±2°C and 90 to 95% humidity for 500±12 hours. Remove and let sit for 24±2 hours at room temperature, then measure. The charge/discharge current is less than 50mA.															
		Appearance		No marking defects.														
		Capacitance Change		Within ±7.5% or ±0.75pF (Whichever is larger)														
		Q		Q≥200														
		I.R.		More than 500MΩ or 25Ω • F (Whichever is smaller)														
	Dielectric Strength	No failure																

Continued on the following page.

www.DataSheet4U.com



## Specifications and Test Methods

 Continued from the preceding page.

No.	Item	Specification	Test Method	
18	High Temperature Load	The measured and observed characteristics shall satisfy the specifications in the following table.	Apply 200% of the rated voltage for 1,000±12 hours at the maximum operating temperature ±3°C. Let sit for 24±2 hours (temperature compensating type) at room temperature, then measure. The charge/discharge current is less than 50mA.	
		Appearance		No marking defects.
		Capacitance Change		Within ±3% or ±0.3pF (Whichever is larger)
		Q		Q≥350
		I.R.		More than 1,000MΩ or 50Ω • F (Whichever is smaller)
	Dielectric Strength	No failure		

Table A

Char.	Nominal Values (ppm/°C) Note 1	Capacitance Change from 25°C (%)					
		-55°C		-30°C		-10°C	
		Max.	Min.	Max.	Min.	Max.	Min.
COG	0±30	0.58	-0.24	0.40	-0.17	0.25	-0.11

Note 1 : Nominal values denote the temperature coefficient within a range of 25°C to 125°C. (for COG)

DataSheet4U.com

# CHIP MONOLITHIC CERAMIC CAPACITOR

## High-Q & High-power GRH/RPN100 Series

### ■ Features(GRH100 Series)

1. The dielectric is composed of low dielectric loss ceramics. This series is perfectly suited to high-frequency applications (VHS-microwave band).
2. The series is ultraminiature, yet has a high-power capacity. This is the best capacitor available for transmitter and amplifier circuits such as those in broadcasting equipment and mobile base stations.
3. GRH110 type is designed for both flow and reflow soldering and GRH111 type is designed for reflow soldering.
4. GRH type capacitors exhibit better solderability and lower solder leaching because of its nickel barriered terminations.

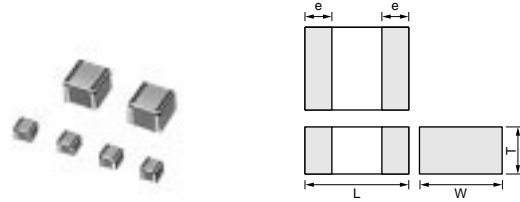

Part Number	Dimensions (mm)			
	L	W	T	e
GRH110	1.4 <sup>+0.6</sup> <sub>-0.4</sub>	1.4 <sup>+0.6</sup> <sub>-0.4</sub>	0.8 to 1.65	0.25 <sup>+0.25</sup> <sub>-0.15</sub>
GRH111	2.8 <sup>+0.6</sup> <sub>-0.4</sub>	2.8 <sup>+0.6</sup> <sub>-0.4</sub>	2.0 to 2.8	0.4 <sup>+0.4</sup> <sub>-0.3</sub>

### ■ Application

High-frequency and high-power circuits.

### ■ Features(RPN100 Series)

1. The dielectric is composed of low dielectric loss ceramics. This series is perfectly suited to high-frequency applications (VHS-microwave band).
2. The series is ultraminiature, yet has a high-power capacity. This is the best capacitor available for transmitter and amplifier circuits such as those in broadcasting equipment and mobile base stations.
3. RPN type capacitors withstand high temperatures because ribbon leads are attached with silver paste.
4. RPN type capacitors are easily soldered and especially well suited in applications where only a soldering iron can be used.

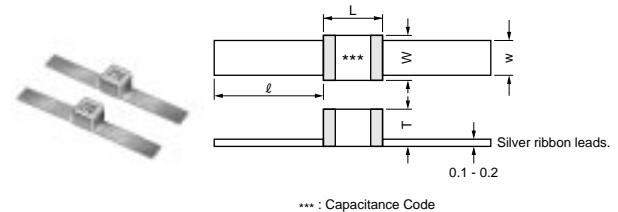

Part Number	Dimensions (mm)				
	L	W	T max.	ℓ	w
RPN110	1.6 ±0.4	1.4 ±0.4	1.6	5.0 min.	1.3 ±0.4
RPN111	3.2 ±0.4	2.8 ±0.4	3.0	9.0 ±2.0	2.35 ±0.15

### ■ Application

High-frequency and high-power circuits.

Part Number	GRH110	GRH111					RPN110	RPN111				
L x W(mm)	1.40x1.40	2.80x2.80					1.60x1.40	3.20x2.80				
TC Code	C0G	C0G					C0G	C0G				
Rated Volt.(Vdc)	50	50	100	200	300	500	50	50	100	200	300	500
Capacitance and T(mm)												
	0.5pF	1.20				2.40	1.60					3.00
	0.6pF	1.20				2.40	1.60					3.00
	0.7pF	1.20				2.40	1.60					3.00
	0.8pF	1.20				2.40	1.60					3.00
	0.9pF	1.20				2.40	1.60					3.00
	1.0pF	1.20				2.40	1.60					3.00
	1.1pF	1.20				2.40	1.60					3.00
	1.2pF	1.20				2.40	1.60					3.00
	1.3pF	1.20				2.40	1.60					3.00
	1.4pF	1.20				2.40	1.60					3.00
	1.5pF	1.20				2.40	1.60					3.00

Continued on the following page.

 Continued from the preceding page.

Part Number	GRH110	GRH111					RPN110	RPN111				
L x W(mm)	1.40x1.40	2.80x2.80					1.60x1.40	3.20x2.80				
TC Code	COG	COG					COG	COG				
Rated Volt.(Vdc)	50	50	100	200	300	500	50	50	100	200	300	500
Capacitance and T(mm)												
1.6pF	1.20					2.40	1.60					3.00
1.7pF	1.20					2.40	1.60					3.00
1.8pF	1.20					2.40	1.60					3.00
1.9pF	1.20					2.40	1.60					3.00
2.0pF	1.20					2.40	1.60					3.00
2.1pF	1.20					2.40	1.60					3.00
2.2pF	1.20					2.40	1.60					3.00
2.4pF	1.20					2.40	1.60					3.00
2.7pF	1.20					2.40	1.60					3.00
3.0pF	1.20					2.40	1.60					3.00
3.3pF	1.20					2.40	1.60					3.00
3.6pF	1.20					2.40	1.60					3.00
3.9pF	1.20					2.40	1.60					3.00
4.3pF	1.20					2.40	1.60					3.00
4.7pF	1.20					2.40	1.60					3.00
5.1pF	1.20					2.40	1.60					3.00
5.6pF	1.20					2.40	1.60					3.00
6.2pF	1.20					2.40	1.60					3.00
6.8pF	1.20					2.40	1.60					3.00
7.5pF	1.20					2.40	1.60					3.00
8.2pF	1.20					2.40	1.60					3.00
9.1pF	1.20					2.40	1.60					3.00
10.0pF	1.20					2.40	1.60					3.00
11pF	1.20					2.40	1.60					3.00
12pF	1.20					2.40	1.60					3.00
13pF	1.20					2.40	1.60					3.00
15pF	1.20					2.40	1.60					3.00
16pF	1.20					2.40	1.60					3.00
18pF	1.20					2.40	1.60					3.00
20pF	1.20					2.40	1.60					3.00
22pF	1.20					2.40	1.60					3.00
24pF	1.20					2.40	1.60					3.00
27pF	1.20					2.40	1.60					3.00
30pF	1.20					2.40	1.60					3.00
33pF	1.20					2.40	1.60					3.00
36pF	1.20					2.40	1.60					3.00
39pF	1.20					2.40	1.60					3.00
43pF	1.20					2.40	1.60					3.00
47pF	1.20					2.40	1.60					3.00
51pF	1.20					2.40	1.60					3.00
56pF	1.20					2.40	1.60					3.00
62pF	1.20					2.40	1.60					3.00
68pF	1.20					2.40	1.60					3.00
75pF	1.20					2.40	1.60					3.00
82pF	1.20					2.40	1.60					3.00
91pF	1.20					2.40	1.60					3.00
100pF	1.20					2.40	1.60					3.00
110pF					2.40							3.00
120pF					2.40							3.00
130pF					2.40							3.00
150pF					2.40							3.00
160pF					2.40							3.00
180pF					2.40							3.00
200pF					2.40							3.00

Continued on the following page. 

 Continued from the preceding page.

Part Number	GRH110	GRH111					RPN110	RPN111				
L x W(mm)	1.40x1.40	2.80x2.80					1.60x1.40	3.20x2.80				
TC Code	COG	COG					COG	COG				
Rated Volt.(Vdc)	50	50	100	200	300	500	50	50	100	200	300	500
Capacitance and T(mm)												
220pF				2.40						3.00		
240pF				2.40						3.00		
270pF				2.40						3.00		
300pF				2.40						3.00		
330pF				2.40						3.00		
360pF				2.40						3.00		
390pF				2.40						3.00		
430pF				2.40						3.00		
470pF				2.40						3.00		
510pF			2.40						3.00			
560pF			2.40						3.00			
620pF			2.40						3.00			
680pF			2.40						3.00			
750pF	2.40							3.00				
820pF	2.40							3.00				
910pF	2.40							3.00				
1000pF	2.40							3.00				

DataSheet4U.com

DataSheet4U.com

DataSheet4U.com

11

DataSheet4U.com

www.DataSheet4U.com

DataSheet4U.com



DataSheet4U.com

51

## Specifications and Test Methods

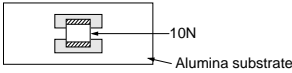
No.	Item	Specification	Test Method												
1	Operating Temperature Range	-55°C to +125°C													
2	Rated Voltage	See the previous pages.	The rated voltage is defined as the maximum voltage which may be applied continuously to the capacitor. When AC voltage is superimposed on DC voltage, $V^{P-P}$ or $V^{O-P}$ , whichever is larger, shall be maintained within the rated voltage range.												
3	Appearance	No defects or abnormalities.	Visual inspection.												
4	Dimensions	Within the specified dimension.	Using calipers.												
5	Dielectric Strength	No defects or abnormalities.	No failure shall be observed when 250% of the rated voltage is applied between the terminations for 1 to 5 seconds, provided the charge/discharge current is less than 50mA.												
6	Insulation Resistance (I.R.)	25°C $C \leq 470\text{pF} : 1,000,000\text{M}\Omega \text{ min.}$ $470\text{pF} < C \leq 1,000\text{pF} : 100,000\text{M}\Omega \text{ min.}$	The insulation resistance shall be measured with a DC voltage not exceeding the rated voltage at 25°C and 125°C standard humidity and within 2 minutes of charging.												
		125°C $C \leq 470\text{pF} : 100,000\text{M}\Omega \text{ min.}$ $470\text{pF} < C \leq 1,000\text{pF} : 10,000\text{M}\Omega \text{ min.}$													
7	Capacitance	Within the specified tolerance.	The capacitance/Q shall be measured at 25°C at the frequency and voltage shown in the table.												
8	Q	$C \leq 220\text{pF} : Q \geq 10,000$ $220\text{pF} < C \leq 470\text{pF} : Q \geq 5,000$ $470\text{pF} < C \leq 1,000\text{pF} : Q \geq 3,000$ C : Nominal Capacitance (pF)	<table border="1"> <thead> <tr> <th>Item</th> <th>Char.</th> <th>COG (1,000pF and below)</th> </tr> </thead> <tbody> <tr> <td>Frequency</td> <td></td> <td>1±0.1MHz</td> </tr> <tr> <td>Voltage</td> <td></td> <td>0.5 to 5Vr.m.s.</td> </tr> </tbody> </table>	Item	Char.	COG (1,000pF and below)	Frequency		1±0.1MHz	Voltage		0.5 to 5Vr.m.s.			
		Item	Char.	COG (1,000pF and below)											
Frequency		1±0.1MHz													
Voltage		0.5 to 5Vr.m.s.													
9	Capacitance Temperature Characteristics	Capacitance Variation Rate Within the specified tolerance. (Table A-7)	<p>The temperature coefficient is determined using the capacitance measured in step 3 as a reference. When cycling the temperature sequentially from step 1 through 5, the capacitance shall be within the specified tolerance for the temperature coefficient and capacitance change as Table A.</p> <p>The capacitance drift is calculated by dividing the differences between the maximum and minimum measured values in the step 1, 3 and 5 by the cap. value in step 3.</p> <p>The capacitance change shall be measured after 5 min. at each specified temperature stage.</p> <table border="1"> <thead> <tr> <th>Step</th> <th>Temperature(°C)</th> </tr> </thead> <tbody> <tr> <td>1</td> <td>25±2</td> </tr> <tr> <td>2</td> <td>-55±3</td> </tr> <tr> <td>3</td> <td>25±2</td> </tr> <tr> <td>4</td> <td>125±3</td> </tr> <tr> <td>5</td> <td>25±2</td> </tr> </tbody> </table>	Step	Temperature(°C)	1	25±2	2	-55±3	3	25±2	4	125±3	5	25±2
		Step		Temperature(°C)											
		1		25±2											
2	-55±3														
3	25±2														
4	125±3														
5	25±2														
Temperature Coefficient Within the specified tolerance. (Table A-7)															
Capacitance Drift Within ±0.2% or ±0.05pF (Whichever is larger)															
10	Terminal Strength	Adhesive Strength of Termination (for chip type) No removal of the terminations or other defects shall occur.	<p>Solder the capacitor to the test jig (alumina substrate) shown in Fig.1 using solder containing 2.5% silver. The soldering shall be done either with an iron or in furnace and be conducted with care so the soldering is uniform and free of defects such as heat shock. Then apply a 10N force in the direction of the arrow.</p>  <p style="text-align: center;">Fig.1</p>												
		Tensile Strength (for micro-strip type) Capacitor shall not be broken or damaged.	The capacitor body is fixed and a load is applied gradually in the axial direction until its value reaches 10N (5N for RPN110).												
		Bending Strength of lead wire terminal (for micro-strip type) Lead wire shall not be cut or broken.	Position the main body of the capacitor so the lead wire terminal is perpendicular, and load 2.5N to the lead wire terminal. Bend the main body by 90 degrees, bend back to original position, bend 90 degrees in the reverse direction, and then bend back to original position.												

Continued on the following page. 

et4U.com

DataShee

11

## Specifications and Test Methods

 Continued from the preceding page.

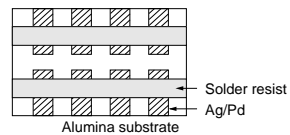
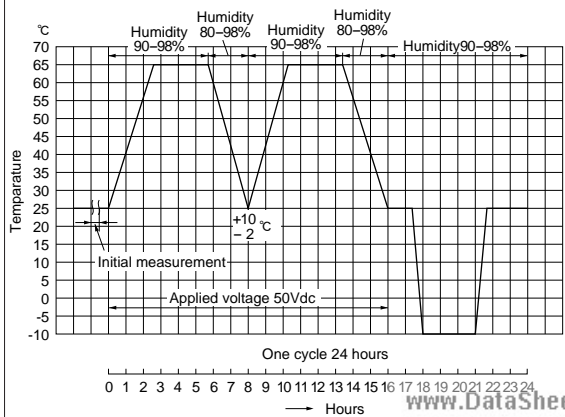
No.	Item	Specification	Test Method									
11	Appearance	No defects or abnormalities.	Solder the capacitor to the test jig (alumina substrate) shown in Fig.2 using solder containing 2.5% silver. The soldering shall be done either with an iron or using the reflow method and shall be conducted with care so the soldering is uniform and free of defects such as heat shock. The capacitor shall be subjected to a simple harmonic motion having a total amplitude of 1.5mm, the frequency being varied uniformly between the approximate limits of 10 and 55Hz. The frequency range, from 10 to 55Hz and return to 10Hz, shall be traversed in approximately 1 minute. This motion shall be applied for a period of 2 hours in each 3 mutually perpendicular directions (total of 6 hours).									
	Capacitance	Within the specified tolerance.										
11	Vibration Resistance	<p>Satisfies the initial value.</p> <p><math>C \leq 220\text{pF} : Q \geq 10,000</math></p> <p><math>220\text{pF} &lt; C \leq 470\text{pF} : Q \geq 5,000</math></p> <p><math>470\text{pF} &lt; C \leq 1,000\text{pF} : Q \geq 3,000</math></p> <p>C : Nominal Capacitance (pF)</p>	 <p style="text-align: center;">Fig. 2</p>									
12	Solderability of Termination	95% of the terminations is to be soldered evenly and continuously.	Immerse the capacitor in a solution of ethanol (JIS-K-8101) and rosin (JIS-K-5902) (25% rosin in weight proportion). Preheat at 80 to 120°C for 10 to 30 seconds. After preheating immerse in solder containing 2.5% silver for 5±0.5 seconds at 230±5°C. The dipping depth for microstrip type capacitors is up to 1 mm from the root of the terminal.									
13	Resistance to Soldering Heat	The measured and observed characteristics shall satisfy the specifications in the following table.	Preheat the capacitor at 80 to 100°C for 2 minutes and then at 150 to 200°C for 5 minutes. Immerse in solder containing 2.5% silver for 3±0.5 seconds at 270±5°C. Set at room temperature for 24±2 hours, then measure. The dipping depth for microstrip type capacitors is up to 2mm from the root of the terminal.									
		<table border="1"> <thead> <tr> <th>Item</th> <th>Specification</th> </tr> </thead> <tbody> <tr> <td>Appearance</td> <td>No marked defect</td> </tr> <tr> <td>Capacitance Change</td> <td>Within ±2.5% or ±0.25pF (Whichever is larger)</td> </tr> <tr> <td>Q</td> <td><math>C \leq 220\text{pF} : Q \geq 10,000</math> <math>220\text{pF} &lt; C \leq 470\text{pF} : Q \geq 5,000</math> <math>470\text{pF} &lt; C \leq 1,000\text{pF} : Q \geq 3,000</math></td> </tr> <tr> <td>I.R.</td> <td>More than 30% of the initial specification value at 25°C.</td> </tr> <tr> <td>Dielectric Strength</td> <td>No failure</td> </tr> </tbody> </table> <p style="text-align: center;">C : Nominal Capacitance (pF)</p>		Item	Specification	Appearance	No marked defect	Capacitance Change	Within ±2.5% or ±0.25pF (Whichever is larger)	Q	$C \leq 220\text{pF} : Q \geq 10,000$ $220\text{pF} < C \leq 470\text{pF} : Q \geq 5,000$ $470\text{pF} < C \leq 1,000\text{pF} : Q \geq 3,000$	I.R.
Item	Specification											
Appearance	No marked defect											
Capacitance Change	Within ±2.5% or ±0.25pF (Whichever is larger)											
Q	$C \leq 220\text{pF} : Q \geq 10,000$ $220\text{pF} < C \leq 470\text{pF} : Q \geq 5,000$ $470\text{pF} < C \leq 1,000\text{pF} : Q \geq 3,000$											
I.R.	More than 30% of the initial specification value at 25°C.											
Dielectric Strength	No failure											
14	Temperature Cycle	The measured and observed characteristics shall satisfy the specifications in the following table.	Fix the capacitor to the supporting jig in the same manner and under the same conditions as (11). Perform the five cycles according to the four heat treatments listed in the following table. Then, repeat twice the successive cycles of immersion, each cycle consisting of immersion in a fresh water at 65±5°C for 15 minutes and immersion in a saturated aqueous solution of salt at 0±3°C for 15 minutes. The capacitor is promptly washed with running water, dried with a dry cloth, and allowed to sit at room temperature for 24±2 hours.									
		<table border="1"> <thead> <tr> <th>Item</th> <th>Specification</th> </tr> </thead> <tbody> <tr> <td>Appearance</td> <td>No marked defect</td> </tr> <tr> <td>Capacitance Change</td> <td>Within ±1% or ±0.25pF (Whichever is larger)</td> </tr> <tr> <td>Q</td> <td><math>C \leq 220\text{pF} : Q \geq 10,000</math> <math>220\text{pF} &lt; C \leq 470\text{pF} : Q \geq 5,000</math> <math>470\text{pF} &lt; C \leq 1,000\text{pF} : Q \geq 3,000</math></td> </tr> <tr> <td>I.R.</td> <td>More than 30% of the initial specification value at 25°C.</td> </tr> <tr> <td>Dielectric Strength</td> <td>No failure</td> </tr> </tbody> </table> <p style="text-align: center;">C : Nominal Capacitance (pF)</p>		Item	Specification	Appearance	No marked defect	Capacitance Change	Within ±1% or ±0.25pF (Whichever is larger)	Q	$C \leq 220\text{pF} : Q \geq 10,000$ $220\text{pF} < C \leq 470\text{pF} : Q \geq 5,000$ $470\text{pF} < C \leq 1,000\text{pF} : Q \geq 3,000$	I.R.
Item	Specification											
Appearance	No marked defect											
Capacitance Change	Within ±1% or ±0.25pF (Whichever is larger)											
Q	$C \leq 220\text{pF} : Q \geq 10,000$ $220\text{pF} < C \leq 470\text{pF} : Q \geq 5,000$ $470\text{pF} < C \leq 1,000\text{pF} : Q \geq 3,000$											
I.R.	More than 30% of the initial specification value at 25°C.											
Dielectric Strength	No failure											
15	Humidity	The measured and observed characteristics shall satisfy the specifications in the following table.	Apply the 24-hour heat (-10 to +65°C) and humidity (80 to 98%) treatment shown below, 10 consecutive times. Remove, set for 24±2 hours at room temperature, and measure.									
		<table border="1"> <thead> <tr> <th>Item</th> <th>Specification</th> </tr> </thead> <tbody> <tr> <td>Appearance</td> <td>No marked defect</td> </tr> <tr> <td>Capacitance Change</td> <td>Within ±5% or ±0.5pF (Whichever is larger)</td> </tr> <tr> <td>Q</td> <td><math>C \leq 220\text{pF} : Q \geq 10,000</math> <math>220\text{pF} &lt; C \leq 470\text{pF} : Q \geq 5,000</math> <math>470\text{pF} &lt; C \leq 1,000\text{pF} : Q \geq 3,000</math></td> </tr> <tr> <td>I.R.</td> <td>More than 30% of the initial specification value at 25°C.</td> </tr> </tbody> </table> <p style="text-align: center;">C : Nominal Capacitance (pF)</p>		Item	Specification	Appearance	No marked defect	Capacitance Change	Within ±5% or ±0.5pF (Whichever is larger)	Q	$C \leq 220\text{pF} : Q \geq 10,000$ $220\text{pF} < C \leq 470\text{pF} : Q \geq 5,000$ $470\text{pF} < C \leq 1,000\text{pF} : Q \geq 3,000$	I.R.
Item	Specification											
Appearance	No marked defect											
Capacitance Change	Within ±5% or ±0.5pF (Whichever is larger)											
Q	$C \leq 220\text{pF} : Q \geq 10,000$ $220\text{pF} < C \leq 470\text{pF} : Q \geq 5,000$ $470\text{pF} < C \leq 1,000\text{pF} : Q \geq 3,000$											
I.R.	More than 30% of the initial specification value at 25°C.											
			 <p style="text-align: center;">One cycle 24 hours</p>									

Continued on the following page. 

## Specifications and Test Methods

 Continued from the preceding page.

No.	Item	Specification	Test Method										
16	High Temperature Load	The measured and observed characteristics shall satisfy the specifications in the following table.	Apply 150% of the rated voltage for 2,000±12 hours at 125±3°C. Remove and set for 24±2 hours at room temperature, then measure. The charge/discharge current is less than 50mA.										
		<table border="1"> <thead> <tr> <th>Item</th> <th>Specification</th> </tr> </thead> <tbody> <tr> <td>Appearance</td> <td>No marked defect</td> </tr> <tr> <td>Capacitance Change</td> <td>Within ±2.5% or ±0.25pF (Whichever is larger)</td> </tr> <tr> <td>Q</td> <td>C ≤ 220pF : Q ≥ 10,000 220pF &lt; C ≤ 470pF : Q ≥ 5,000 470pF &lt; C ≤ 1,000pF : Q ≥ 3,000</td> </tr> <tr> <td>I.R.</td> <td>More than 30% of the initial specification value at 25°C.</td> </tr> </tbody> </table>		Item	Specification	Appearance	No marked defect	Capacitance Change	Within ±2.5% or ±0.25pF (Whichever is larger)	Q	C ≤ 220pF : Q ≥ 10,000 220pF < C ≤ 470pF : Q ≥ 5,000 470pF < C ≤ 1,000pF : Q ≥ 3,000	I.R.	More than 30% of the initial specification value at 25°C.
		Item		Specification									
		Appearance		No marked defect									
		Capacitance Change		Within ±2.5% or ±0.25pF (Whichever is larger)									
Q	C ≤ 220pF : Q ≥ 10,000 220pF < C ≤ 470pF : Q ≥ 5,000 470pF < C ≤ 1,000pF : Q ≥ 3,000												
I.R.	More than 30% of the initial specification value at 25°C.												
C : Nominal Capacitance (pF)													

Table A

Char.	Temp. Coeff. (ppm/°C) Note 1	Capacitance Change from 25°C Value (%)					
		-55°C		-30°C		-10°C	
		Max.	Min.	Max.	Min.	Max.	Min.
COG	0±30	0.58	-0.24	0.40	-0.17	0.25	-0.11

Note 1 : Nominal values denote the temperature coefficient within a range of 25 to 125°C.

DataSheet4U.com

et4U.com

DataShe

# CHIP MONOLITHIC CERAMIC CAPACITOR

## High-frequency GRH/RPN700 Series

### ■ Features(GRH700 Series)

1. Negligible inductance is achieved by its monolithic structure so the series can be used at frequencies above 1GHz.
2. Nickel barriered terminations of GRH type improve solderability and decrease solder leaching.
3. GRH706/GRH708 type is designed for both flow and reflow soldering and GRH710 type is designed for reflow soldering.

### ■ Application

High-frequency and high-power circuits.

### ■ Features(RPN700 Series)

1. Negligible inductance is achieved by its monolithic structure so the series can be used at frequencies above 1GHz.
2. RPN type capacitors withstand at high temperatures because ribbon leads are attached with silver paste.
3. RPN type capacitors are easily soldered and are especially well suited in applications where only a soldering iron can be used.

### ■ Application

High-frequency and high-power circuits.

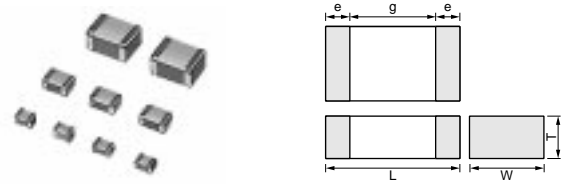

Part Number	Dimensions (mm)				
	L	W	T max.	e	g min.
<b>GRH706</b>	1.25 <sup>+0.5</sup> <sub>-0.3</sub>	1.0 <sup>+0.5</sup> <sub>-0.3</sub>	1.2	0.15 min.	0.3
<b>GRH708</b>	2.0 <sup>+0.5</sup> <sub>-0.3</sub>	1.25 <sup>+0.5</sup> <sub>-0.3</sub>	1.45	0.2 max.	0.5
<b>GRH710</b>	3.2 <sup>+0.6</sup> <sub>-0.4</sub>	2.5 <sup>+0.5</sup> <sub>-0.3</sub>	1.9	0.3 max.	0.5

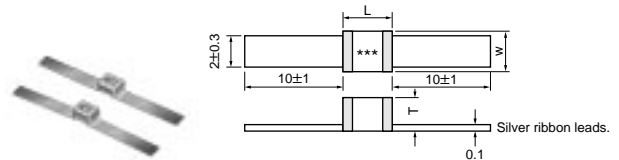

\*\*\* : Capacitance Code

Part Number	Dimensions (mm)		
	L max.	W max.	T max.
<b>RPN710</b>	4.0	3.0	2.3

DataSheet4U

Part Number	<b>GRH706</b>			<b>GRH708</b>			<b>GRH710</b>			<b>RPN710</b>		
L x W(mm)	1.25x1.00			2.00x1.25			3.20x2.50			4.00x3.00		
TC Code	COG			COG			COG			COG		
Rated Volt.(Vdc)	50	100	200	50	100	200	50	100	200	50	100	200
Capacitance and T(mm)												
0.5pF			1.20			1.45			1.90			2.30
0.6pF			1.20			1.45			1.90			2.30
0.7pF			1.20			1.45			1.90			2.30
0.8pF			1.20			1.45			1.90			2.30
0.9pF			1.20			1.45			1.90			2.30
1.0pF			1.20			1.45			1.90			2.30
1.1pF			1.20			1.45			1.90			2.30
1.2pF			1.20			1.45			1.90			2.30
1.3pF			1.20			1.45			1.90			2.30
1.4pF			1.20			1.45			1.90			2.30
1.5pF			1.20			1.45			1.90			2.30
1.6pF			1.20			1.45			1.90			2.30
1.7pF			1.20			1.45			1.90			2.30
1.8pF			1.20			1.45			1.90			2.30
1.9pF			1.20			1.45			1.90			2.30
2.0pF			1.20			1.45			1.90			2.30
2.1pF			1.20			1.45			1.90			2.30
2.2pF			1.20			1.45			1.90			2.30
2.4pF			1.20			1.45			1.90			2.30
2.7pF			1.20			1.45			1.90			2.30

www.DataSheet4U.com

Continued on the following page.



 Continued from the preceding page.

Part Number	GRH706			GRH708			GRH710			RPN710		
L x W(mm)	1.25x1.00			2.00x1.25			3.20x2.50			4.00x3.00		
TC Code	C0G			C0G			C0G			C0G		
Rated Volt.(Vdc)	50	100	200	50	100	200	50	100	200	50	100	200
Capacitance and T(mm)												
3.0pF			1.20			1.45			1.90			2.30
3.3pF			1.20			1.45			1.90			2.30
3.6pF			1.20			1.45			1.90			2.30
3.9pF			1.20			1.45			1.90			2.30
4.3pF			1.20			1.45			1.90			2.30
4.7pF			1.20			1.45			1.90			2.30
5.1pF			1.20			1.45			1.90			2.30
5.6pF			1.20			1.45			1.90			2.30
6.2pF			1.20			1.45			1.90			2.30
6.8pF			1.20			1.45			1.90			2.30
7.5pF			1.20			1.45			1.90			2.30
8.2pF			1.20			1.45			1.90			2.30
9.1pF			1.20			1.45			1.90			2.30
10pF			1.20			1.45			1.90			2.30
11pF			1.20			1.45			1.90			2.30
12pF			1.20			1.45			1.90			2.30
13pF			1.20			1.45			1.90			2.30
15pF		1.20				1.45			1.90			2.30
16pF		1.20				1.45			1.90			2.30
18pF		1.20				1.45			1.90			2.30
20pF		1.20				1.45			1.90			2.30
22pF		1.20				1.45			1.90			2.30
24pF	1.20					1.45			1.90			2.30
27pF	1.20					1.45			1.90			2.30
30pF	1.20					1.45			1.90			2.30
33pF	1.20					1.45			1.90			2.30
36pF	1.20					1.45			1.90			2.30
39pF	1.20					1.45			1.90			2.30
43pF	1.20					1.45			1.90			2.30
47pF	1.20					1.45			1.90			2.30
51pF	1.20					1.45			1.90			2.30
56pF					1.45				1.90			2.30
62pF					1.45				1.90			2.30
68pF					1.45				1.90			2.30
75pF					1.45				1.90			2.30
82pF					1.45				1.90			2.30
91pF					1.45				1.90			2.30
100pF				1.45					1.90			2.30
110pF				1.45					1.90			2.30
120pF				1.45					1.90			2.30
130pF				1.45					1.90			2.30
150pF				1.45					1.90			2.30
160pF				1.45					1.90			2.30
180pF								1.90			2.30	
200pF								1.90			2.30	
220pF								1.90			2.30	
240pF								1.90			2.30	
270pF								1.90			2.30	
300pF								1.90			2.30	
330pF								1.90			2.30	
360pF								1.90			2.30	
390pF								1.90			2.30	
430pF								1.90			2.30	
470pF								1.90			2.30	

Continued on the following page. 

 Continued from the preceding page.

Part Number	GRH706			GRH708			GRH710			RPN710		
L x W(mm)	1.25x1.00			2.00x1.25			3.20x2.50			4.00x3.00		
TC Code	C0G			C0G			C0G			C0G		
Rated Volt.(Vdc)	50	100	200	50	100	200	50	100	200	50	100	200
<b>Capacitance and T(mm)</b>												
510pF								1.90			2.30	
560pF							1.90			2.30		
620pF							1.90			2.30		
680pF							1.90			2.30		
750pF							1.90			2.30		
820pF							1.90			2.30		
910pF							1.90			2.30		
1000pF							1.90			2.30		

DataSheet4U.com

et4U.com

DataShee

12

## Specifications and Test Methods

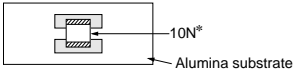
No.	Item	Specification	Test Method									
1	Operating Temperature Range	-55°C to +125°C										
2	Rated Voltage	See the previous pages.	The rated voltage is defined as the maximum voltage which may be applied continuously to the capacitor. When AC voltage is superimposed on DC voltage, $V^{P-P}$ or $V^{O-P}$ , whichever is larger, shall be maintained within the rated voltage range.									
3	Appearance	No defects or abnormalities.	Visual inspection.									
4	Dimensions	Within the specified dimension.	Using calipers.									
5	Dielectric Strength	No defects or abnormalities.	No failure shall be observed when 300% of the rated voltage is applied between the terminations for 1 to 5 seconds, provided the charge/discharge current is less than 50mA.									
6	Insulation Resistance (I.R.)	10,000MΩ min.	The insulation resistance shall be measured with a DC voltage not exceeding the rated voltage at 25°C and standard humidity and within 2 minutes of charging.									
7	Capacitance	Within the specified tolerance.	The capacitance/Q shall be measured at 25°C at the frequency and voltage shown in the table.									
8	Q	$C \leq 220\text{pF} : Q \geq 10,000$ $220\text{pF} < C \leq 470\text{pF} : Q \geq 5,000$ $470\text{pF} < C \leq 1,000\text{pF} : Q \geq 3,000$ C : Nominal Capacitance (pF)	<table border="1"> <thead> <tr> <th>Item</th> <th>Char.</th> <th>COG (1,000pF and below)</th> </tr> </thead> <tbody> <tr> <td>Frequency</td> <td></td> <td>1±0.1MHz</td> </tr> <tr> <td>Voltage</td> <td></td> <td>0.5 to 5Vr.m.s.</td> </tr> </tbody> </table>	Item	Char.	COG (1,000pF and below)	Frequency		1±0.1MHz	Voltage		0.5 to 5Vr.m.s.
			Item	Char.	COG (1,000pF and below)							
Frequency		1±0.1MHz										
Voltage		0.5 to 5Vr.m.s.										
9	Capacitance Temperature Characteristics	Capacitance Variation Rate	Within the specified tolerance. (Table A-6)									
		Temperature Coefficient	Within the specified tolerance. (Table A-6)									
		Capacitance Drift	Within ±0.2% or ±0.05pF (Whichever is larger)									
10	Terminal Strength	Adhesive Strength of Termination (for chip type)	No removal of the terminations or other defects shall occur.  <div style="text-align: right;">*5N (GRH 706)</div>  <p style="text-align: center;">Fig.1</p>									
		Tensile Strength (for micro-strip type)	Capacitor shall not be broken or damaged.									
		Bending Strength of lead wire terminal (for micro-strip type)	Lead wire shall not be cut or broken.									

Continued on the following page. 

## Specifications and Test Methods

Continued from the preceding page.

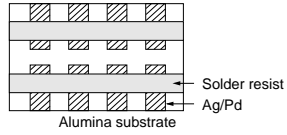
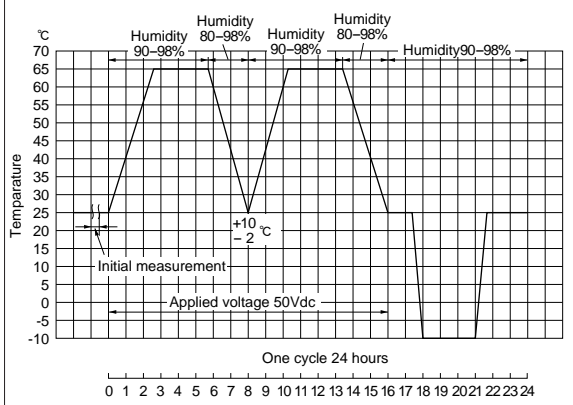
No.	Item	Specification	Test Method																									
11	Appearance	No defects or abnormalities.	Solder the capacitor to the test jig (alumina substrate) shown in Fig.2 using solder containing 2.5% silver. The soldering shall be done either with an iron or using the reflow method and shall be conducted with care so the soldering is uniform and free of defects such as heat shock. The capacitor shall be subjected to a simple harmonic motion having a total amplitude of 1.5mm, the frequency being varied uniformly between the approximate limits of 10 and 55Hz. The frequency range, from 10 to 55Hz and return to 10Hz, shall be traversed in approximately 1 minute. This motion shall be applied for a period of 2 hours in each 3 mutually perpendicular directions (total of 6 hours).																									
	Capacitance	Within the specified tolerance.																										
11	Vibration Resistance	Satisfies the initial value. $C \leq 220\text{pF} : Q \geq 10,000$ $220\text{pF} < C \leq 470\text{pF} : Q \geq 5,000$ $470\text{pF} < C \leq 1,000\text{pF} : Q \geq 3,000$ C : Nominal Capacitance (pF)	 <p style="text-align: center;">Fig.2</p>																									
12	Solderability of Termination	75% of the terminations is to be soldered evenly and continuously.	Immerse the capacitor in a solution of ethanol (JIS-K-8101) and rosin (JIS-K-5902) (25% rosin in weight proportion). Preheat at 80 to 120°C for 10 to 30 seconds. After preheating immerse in solder containing 2.5% silver for 5±0.5 seconds at 230±5°C. The dipping depth for microstrip type capacitors is up to 1 mm from the root of the terminal.																									
13	Resistance to Soldering Heat	The measured and observed characteristics shall satisfy the specifications in the following table.	Preheat according to the conditions listed in the table below. Immerse in solder containing 2.5% silver for 3±0.5 seconds at 270±5°C. Set at room temperature for 24±2 hours, then measure. The dipping depth for microstrip type capacitors is up to 2mm from the root of the terminal.																									
		<table border="1" style="width: 100%;"> <thead> <tr> <th>Item</th> <th>Specification</th> </tr> </thead> <tbody> <tr> <td>Appearance</td> <td>No marked defect</td> </tr> <tr> <td>Capacitance Change</td> <td>Within ±2.5% or ±0.25pF (Whichever is larger)</td> </tr> <tr> <td>Q</td> <td> <math>C \leq 220\text{pF} : Q \geq 10,000</math>  <math>220\text{pF} &lt; C \leq 470\text{pF} : Q \geq 5,000</math>  <math>470\text{pF} &lt; C \leq 1,000\text{pF} : Q \geq 3,000</math> </td> </tr> <tr> <td>Dielectric Strength</td> <td>No failure</td> </tr> </tbody> </table> <p style="text-align: center;">C : Nominal Capacitance (pF)</p>		Item	Specification	Appearance	No marked defect	Capacitance Change	Within ±2.5% or ±0.25pF (Whichever is larger)	Q	$C \leq 220\text{pF} : Q \geq 10,000$ $220\text{pF} < C \leq 470\text{pF} : Q \geq 5,000$ $470\text{pF} < C \leq 1,000\text{pF} : Q \geq 3,000$	Dielectric Strength	No failure	<table border="1" style="width: 100%;"> <thead> <tr> <th>Chip Size</th> <th>Preheat Condition</th> </tr> </thead> <tbody> <tr> <td>2.0X1.25mm max.</td> <td>1minute at 120 to 150°C</td> </tr> <tr> <td>3.2X2.5mm</td> <td>Each 1 minute at 100 to 120°C and then 170 to 200°C</td> </tr> </tbody> </table>	Chip Size	Preheat Condition	2.0X1.25mm max.	1minute at 120 to 150°C	3.2X2.5mm	Each 1 minute at 100 to 120°C and then 170 to 200°C								
Item	Specification																											
Appearance	No marked defect																											
Capacitance Change	Within ±2.5% or ±0.25pF (Whichever is larger)																											
Q	$C \leq 220\text{pF} : Q \geq 10,000$ $220\text{pF} < C \leq 470\text{pF} : Q \geq 5,000$ $470\text{pF} < C \leq 1,000\text{pF} : Q \geq 3,000$																											
Dielectric Strength	No failure																											
Chip Size	Preheat Condition																											
2.0X1.25mm max.	1minute at 120 to 150°C																											
3.2X2.5mm	Each 1 minute at 100 to 120°C and then 170 to 200°C																											
14	Temperature Cycle	The measured and observed characteristics shall satisfy the specifications in the following table.	Fix the capacitor to the supporting jig in the same manner and under the same conditions as (11). Perform the five cycles according to the four heat treatments listed in the following table. Let sit for 24±2 hours at room temperature, then measure.																									
		<table border="1" style="width: 100%;"> <thead> <tr> <th>Item</th> <th>Specification</th> </tr> </thead> <tbody> <tr> <td>Appearance</td> <td>No marked defect</td> </tr> <tr> <td>Capacitance Change</td> <td>Within ±5% or ±0.5pF (Whichever is larger)</td> </tr> <tr> <td>Q</td> <td> <math>C \geq 30\text{pF} : Q \geq 350</math>  <math>10\text{pF} \leq C &lt; 30\text{pF} : Q \geq 275 + \frac{5}{2} C</math>  <math>C &lt; 10\text{pF} : Q \geq 200 + 10C</math> </td> </tr> <tr> <td>I.R.</td> <td>1,000MΩ min.</td> </tr> <tr> <td>Dielectric Strength</td> <td>No failure</td> </tr> </tbody> </table> <p style="text-align: center;">C : Nominal Capacitance (pF)</p>		Item	Specification	Appearance	No marked defect	Capacitance Change	Within ±5% or ±0.5pF (Whichever is larger)	Q	$C \geq 30\text{pF} : Q \geq 350$ $10\text{pF} \leq C < 30\text{pF} : Q \geq 275 + \frac{5}{2} C$ $C < 10\text{pF} : Q \geq 200 + 10C$	I.R.	1,000MΩ min.	Dielectric Strength	No failure	<table border="1" style="width: 100%;"> <thead> <tr> <th>Step</th> <th>1</th> <th>2</th> <th>3</th> <th>4</th> </tr> </thead> <tbody> <tr> <td>Temp.(°C)</td> <td>-55<sup>+0</sup><sub>-3</sub></td> <td>RoomTemp.</td> <td>125<sup>+3</sup><sub>-0</sub></td> <td>RoomTemp.</td> </tr> <tr> <td>Time(min.)</td> <td>30±3</td> <td>2 to 3</td> <td>30±3</td> <td>2 to 3</td> </tr> </tbody> </table>	Step	1	2	3	4	Temp.(°C)	-55 <sup>+0</sup> <sub>-3</sub>	RoomTemp.	125 <sup>+3</sup> <sub>-0</sub>	RoomTemp.	Time(min.)	30±3
Item	Specification																											
Appearance	No marked defect																											
Capacitance Change	Within ±5% or ±0.5pF (Whichever is larger)																											
Q	$C \geq 30\text{pF} : Q \geq 350$ $10\text{pF} \leq C < 30\text{pF} : Q \geq 275 + \frac{5}{2} C$ $C < 10\text{pF} : Q \geq 200 + 10C$																											
I.R.	1,000MΩ min.																											
Dielectric Strength	No failure																											
Step	1	2	3	4																								
Temp.(°C)	-55 <sup>+0</sup> <sub>-3</sub>	RoomTemp.	125 <sup>+3</sup> <sub>-0</sub>	RoomTemp.																								
Time(min.)	30±3	2 to 3	30±3	2 to 3																								
15	Humidity	The measured and observed characteristics shall satisfy the specifications in the following table.	Apply the 24-hour heat (-10 to +65°C) and humidity (80 to 98%) treatment shown below, 10 consecutive times. Remove, set for 24±2 hours at room temperature, and measure.																									
		<table border="1" style="width: 100%;"> <thead> <tr> <th>Item</th> <th>Specification</th> </tr> </thead> <tbody> <tr> <td>Appearance</td> <td>No marked defect</td> </tr> <tr> <td>Capacitance Change</td> <td>Within ±5% or ±0.5pF (Whichever is larger)</td> </tr> <tr> <td>Q</td> <td> <math>C \geq 30\text{pF} : Q \geq 350</math>  <math>10\text{pF} \leq C &lt; 30\text{pF} : Q \geq 275 + \frac{5}{2} C</math>  <math>C &lt; 10\text{pF} : Q \geq 200 + 10C</math> </td> </tr> <tr> <td>I.R.</td> <td>1,000MΩ min.</td> </tr> </tbody> </table> <p style="text-align: center;">C : Nominal Capacitance (pF)</p>		Item	Specification	Appearance	No marked defect	Capacitance Change	Within ±5% or ±0.5pF (Whichever is larger)	Q	$C \geq 30\text{pF} : Q \geq 350$ $10\text{pF} \leq C < 30\text{pF} : Q \geq 275 + \frac{5}{2} C$ $C < 10\text{pF} : Q \geq 200 + 10C$	I.R.	1,000MΩ min.															
Item	Specification																											
Appearance	No marked defect																											
Capacitance Change	Within ±5% or ±0.5pF (Whichever is larger)																											
Q	$C \geq 30\text{pF} : Q \geq 350$ $10\text{pF} \leq C < 30\text{pF} : Q \geq 275 + \frac{5}{2} C$ $C < 10\text{pF} : Q \geq 200 + 10C$																											
I.R.	1,000MΩ min.																											

Continued on the following page.

www.DataSheet4U.com

## Specifications and Test Methods

 Continued from the preceding page.

No.	Item	Specification	Test Method										
16	High Temperature Load	<p>The measured and observed characteristics shall satisfy the specifications in the following table.</p> <table border="1"> <thead> <tr> <th>Item</th> <th>Specification</th> </tr> </thead> <tbody> <tr> <td>Appearance</td> <td>No marked defect</td> </tr> <tr> <td>Capacitance Change</td> <td>Within <math>\pm 3\%</math> or <math>\pm 0.3\text{pF}</math> (Whichever is larger)</td> </tr> <tr> <td>Q</td> <td><math>C \geq 30\text{pF} : Q \geq 350</math> <math>10\text{pF} \leq C &lt; 30\text{pF} : Q \geq 275 + \frac{C}{10}</math> <math>C &lt; 10\text{pF} : Q \geq 200 + 10C</math></td> </tr> <tr> <td>I.R.</td> <td>1,000M<math>\Omega</math> min.</td> </tr> </tbody> </table> <p style="text-align: center;">C : Nominal Capacitance (pF)</p>	Item	Specification	Appearance	No marked defect	Capacitance Change	Within $\pm 3\%$ or $\pm 0.3\text{pF}$ (Whichever is larger)	Q	$C \geq 30\text{pF} : Q \geq 350$ $10\text{pF} \leq C < 30\text{pF} : Q \geq 275 + \frac{C}{10}$ $C < 10\text{pF} : Q \geq 200 + 10C$	I.R.	1,000M $\Omega$ min.	<p>Apply 200% of the rated voltage for 1,000<math>\pm</math>12 hours at 125<math>\pm</math>3<math>^{\circ}</math>C. Remove and set for 24<math>\pm</math>2 hours at room temperature, then measure.</p> <p>The charge/discharge current is less than 50mA.</p>
Item	Specification												
Appearance	No marked defect												
Capacitance Change	Within $\pm 3\%$ or $\pm 0.3\text{pF}$ (Whichever is larger)												
Q	$C \geq 30\text{pF} : Q \geq 350$ $10\text{pF} \leq C < 30\text{pF} : Q \geq 275 + \frac{C}{10}$ $C < 10\text{pF} : Q \geq 200 + 10C$												
I.R.	1,000M $\Omega$ min.												

Table A

Char.	Temperature Coefficient (ppm/ $^{\circ}$ C) Note 1	Capacitance Change from 25 $^{\circ}$ C Value (%)					
		-55 $^{\circ}$ C		-30 $^{\circ}$ C		-10 $^{\circ}$ C	
		Max.	Min.	Max.	Min.	Max.	Min.
COG	0 $\pm$ 30	0.58	-0.24	0.40	-0.17	0.25	-0.11

Note 1 : Nominal values denote the temperature coefficient within a range of 25 to 125 $^{\circ}$ C.

DataSheet4U.com

et4U.com

DataShee

# GRH/RPN Series Data

## ■ Q-Frequency Characteristics

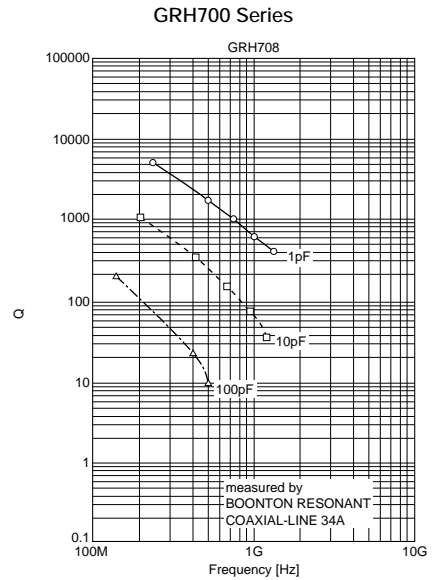
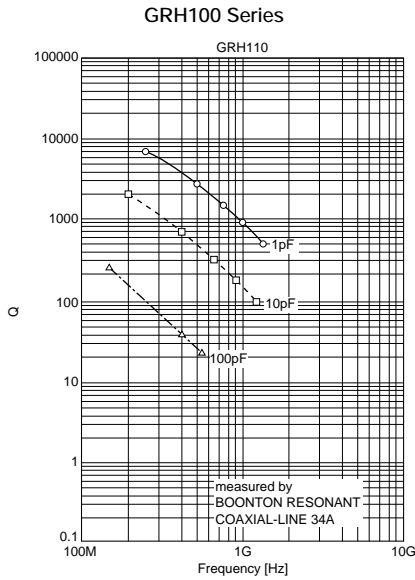

## ■ Impedance-Frequency Characteristics

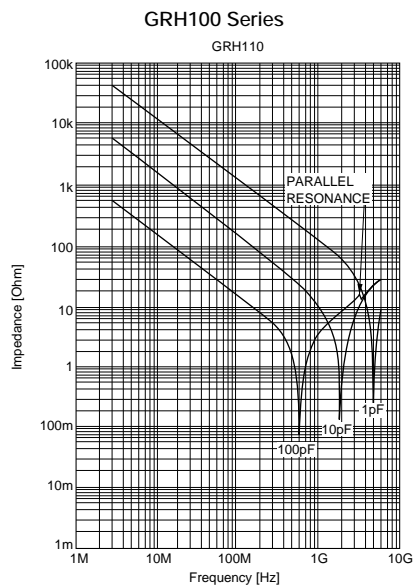

DataSheet4U.com

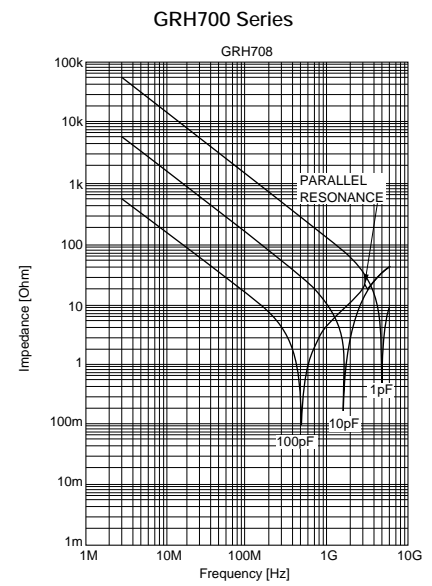

DataSheet4U.com

## ■ ESR-Frequency Characteristics

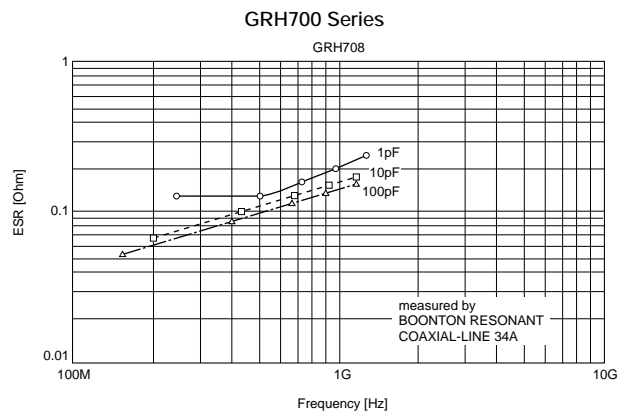
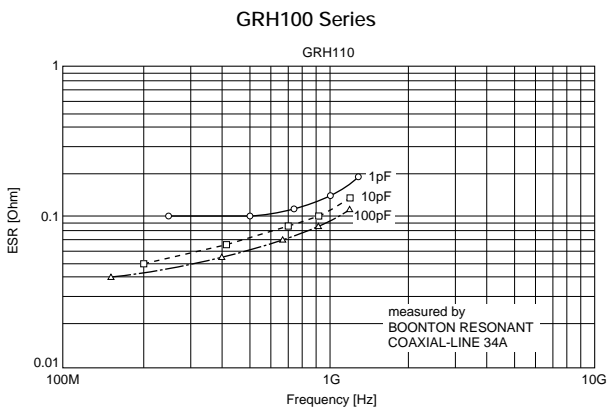

Continued on the following page.

# GRH/RPN Series Data

Continued from the preceding page.

## Resonant Frequency-Capcitrance

GRH100 Series

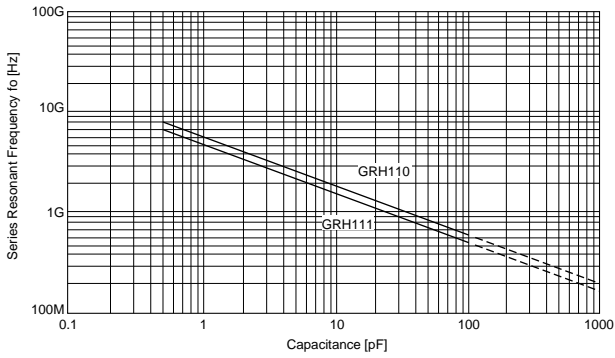

GRH700 Series

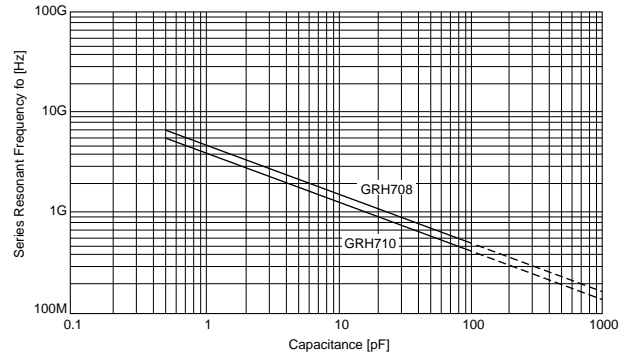

## Allowable Voltage-Frequency

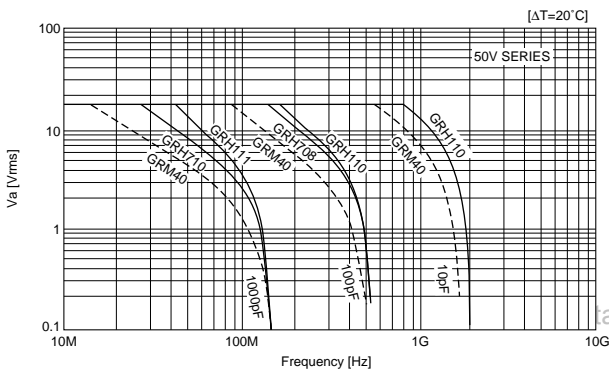

## Allowable Current-Frequency

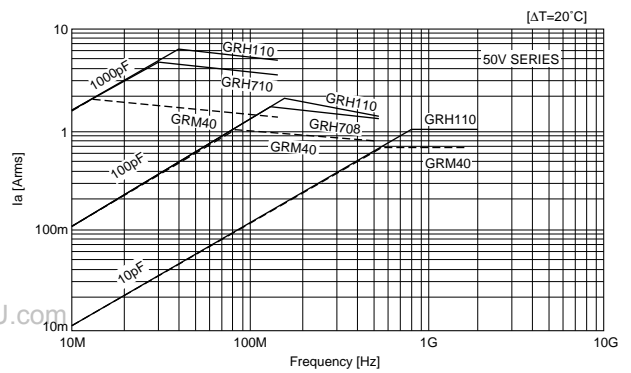

## Allowable Apparent Power-Frequency

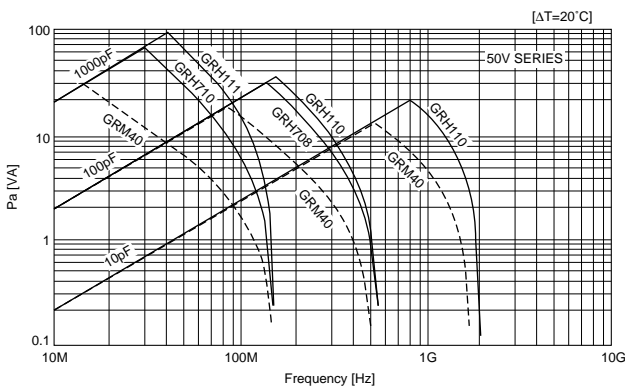

## Allowable Effective Power-Frequency

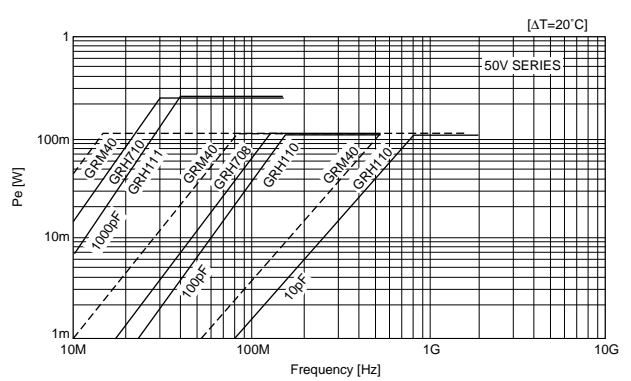

■ Packaging Code

Packaging Type	Tape Carrier Packaging	Bulk Case Packaging	Bulk Packaging	
			Bulk Packaging in a bag	Bulk Packaging in a tray
Packaging Code	PT	PC	PB	PM

■ Minimum Quantity Guide

Part Number		Dimensions (mm)			Quantity (pcs.)					
					φ180mm reel		φ330mm reel		Bulk Case	Bulk Bag
		L	W	T	Paper Tape	Plastic Tape	Paper Tape	Plastic Tape		
Ultra-miniaturized	GRM33	0.6	0.3	0.3	15,000	-	-	-	-	1,000
	GRM36	1.0	0.5	0.5	10,000	-	50,000	-	50,000	1,000
For Flow/Reflow	GRM39	1.6	0.8	0.8	4,000	-	10,000	-	15,000 <sup>1)</sup>	1,000 <sup>1)</sup>
	GRM40	2.0	1.25	0.6	4,000	-	10,000	-	10,000	1,000
				0.85	4,000	-	10,000	-	-	1,000
				1.25	-	3,000	-	10,000	5,000	1,000
	GRM42-6	3.2	1.6	0.85	4,000	-	10,000	-	-	1,000
				1.15	-	3,000	-	10,000	-	1,000
				1.6	-	2,000	-	6,000	-	1,000
For Reflow	GRM42-2	3.2	2.5	1.15	-	3,000	-	10,000	-	1,000
				1.35	-	2,000	-	8,000	-	1,000
				1.8	-	1,000	-	4,000	-	1,000
				2.5	-	1,000	-	4,000	-	1,000
	GRM43-2	4.5	3.2	2.0	-	1,000	-	4,000 <sup>2)</sup>	-	1,000
	GRM44-1	5.7	5.0	2.0	-	1,000	-	4,000 <sup>2)</sup>	-	1,000
High-power Type	GRM615	1.0	0.5	0.5	10,000	-	50,000	-	50,000	1,000
Low-distortion Series	GRM420	1.6	0.8	0.8	4,000	-	10,000	-	-	1,000
	GRM425	2.0	1.25	0.7	4,000	-	10,000	-	-	1,000
				1.0	4,000	-	10,000	-	-	1,000
	GRM430	3.2	1.6	0.7	4,000	-	10,000	-	-	1,000
				1.25	-	3,000	-	10,000	-	1,000
	GRM435	4.5	2.5	2.0	-	1,000	-	4,000	-	1,000
	High-frequency	GRQ706	1.6	0.8	0.8	4,000	-	10,000	-	-
GRQ708		2.0	1.25	1.0	4,000	-	10,000	-	-	1,000
GRH706		1.25	1.0	1.2	-	-	-	-	-	1,000
GRH708		2.0	1.25	1.45	-	3,000	-	-	-	1,000
GRH710		3.2	2.5	1.9	-	2,000	-	-	-	1,000
GRH110		1.4	1.4	1.65	-	2,000	-	-	-	1,000
GRH111		2.8	2.8	2.8	-	1,000	-	-	-	1,000
For Ultrasonic	GRM40	2.0	1.25	0.85	4,000	-	10,000	-	-	1,000
Micro Chip	GM250	0.5	0.5	0.35	-	-	-	-	-	400 <sup>3)</sup>
	GM260	0.8	0.8	0.5	-	-	-	-	-	400 <sup>3)</sup>
Array	GNM30-401	3.2	1.6	0.8	4,000	-	10,000	-	-	1,000
Low ESL	LL0306	0.8	1.6	0.6	4,000	-	10,000	-	-	1,000
	LL0508	1.25	2.0	1.0	-	4,000 <sup>4)</sup>	-	10,000	-	1,000
				0.7	-	4,000	-	10,000	-	1,000
LL0612	1.6	3.2	1.25	-	3,000	-	10,000	-	1,000	

- 1) 0.15 μF and 0.22 μF of X7R, 10V rated are available by taping packages only. (Applied to neither bulk case nor bag package.) 560pF of COG, 50V rated and 0.47μF or 1.0μF of X5R, 6.3V rated are not available by bulk case. (Applied to taping or bag packages only.)
- 2) Depending on capacitance, some products are supplied on the 5,000pcs./reel basis.
- 3) Tray
- 4) Depending on capacitance, some products are supplied on the 3,000 pcs./reel basis.

Continued on the following page. 



# Package

Continued from the preceding page.

## ■ Tape Carrier Packaging

### (1) Dimensions of Reel

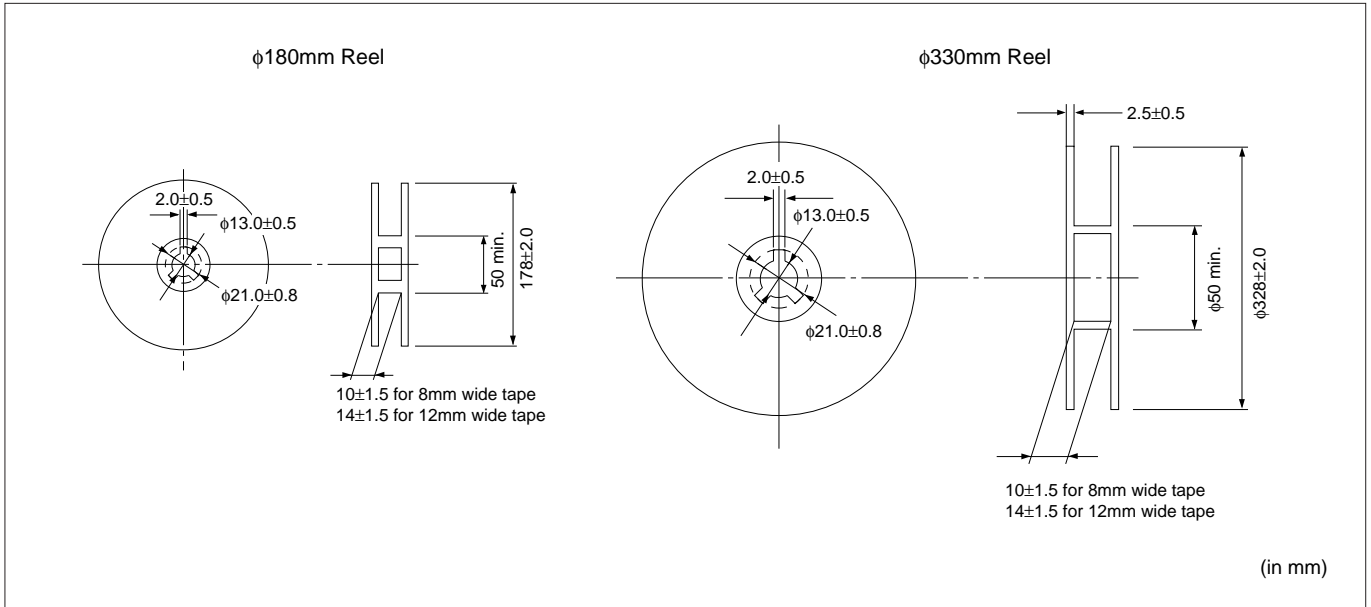

### (2) Dimensions of Paper Tape

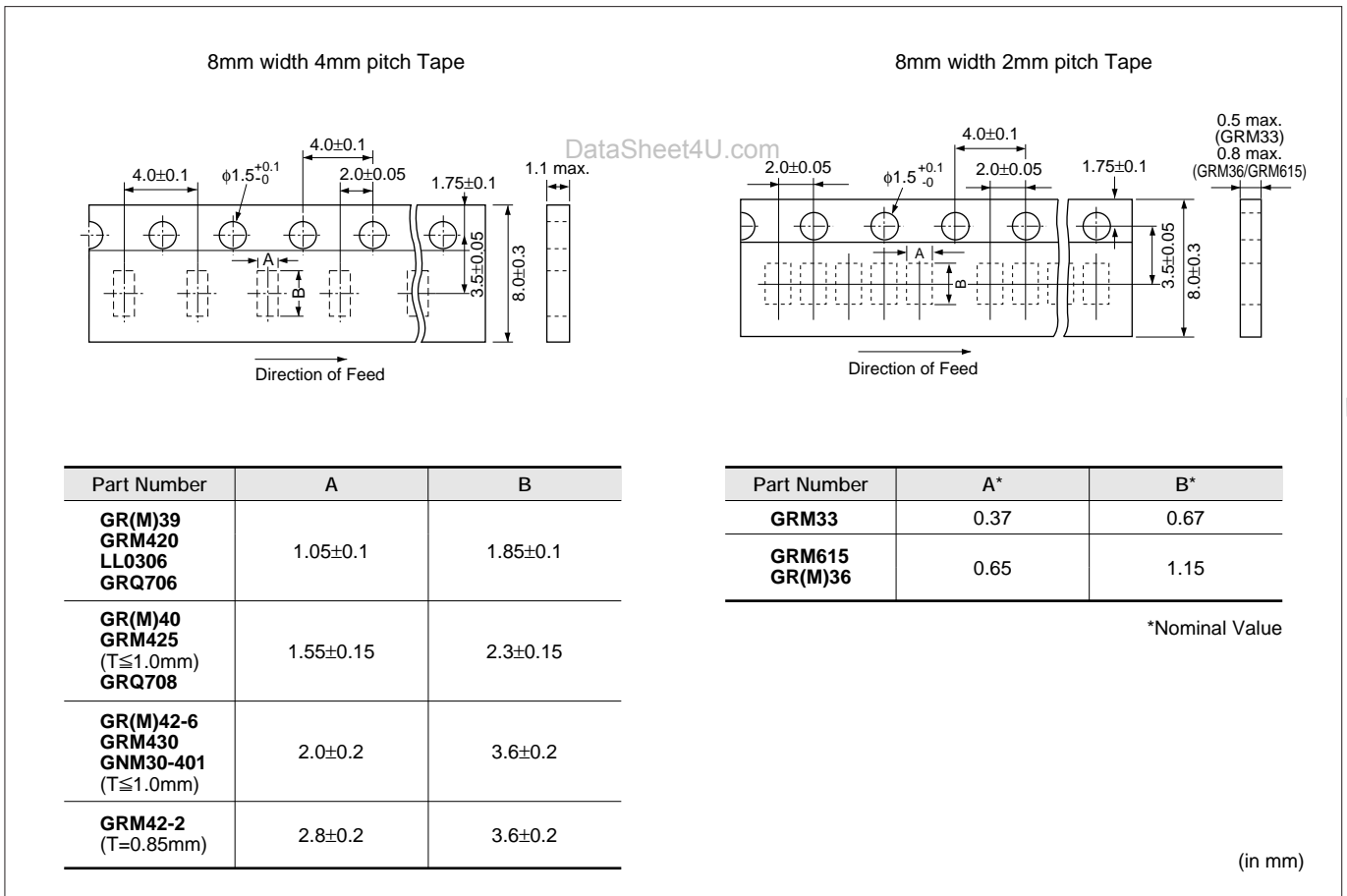

Continued on the following page.

Continued from the preceding page.

(3) Dimensions of Plastic Tape

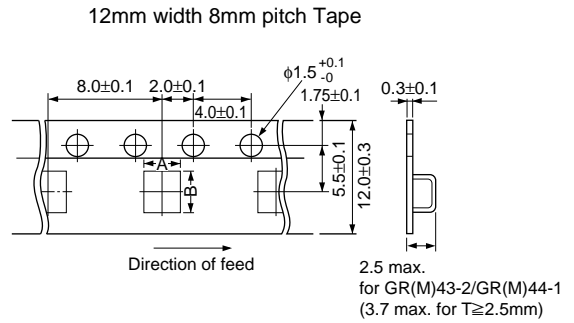
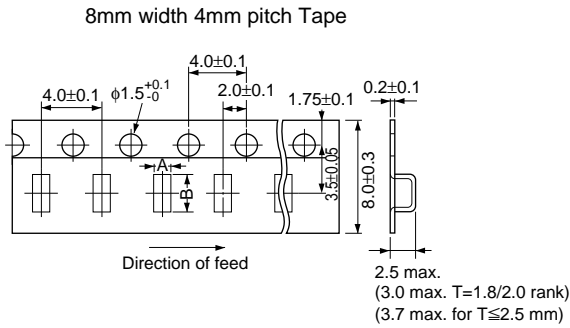

Part Number	A	B
<b>GR(M)40</b> (T=1.25mm) <b>LL0508</b>	1.45±0.2	2.25±0.2
<b>GR(M)42-6</b> <b>GRM430</b> (T≥1.15mm) <b>LL0612</b>	1.9±0.2	3.5±0.2
<b>GRM435</b> <b>GR(M)42-2</b> (T≥1.15mm)	2.8±0.2	3.5±0.2
<b>GRH708</b>	1.8*	2.6*
<b>GRH710</b>	2.8*	3.5*
<b>GRH110</b>	2.0*	2.1*
<b>GRH111</b>	3.1*	3.2*

Part Number	A*	B*
<b>GR(M)43-2</b>	3.6	4.9
<b>GR(M)44-1</b>	5.2	6.1

\*Nominal Value

\*Nominal Value

(in mm)

(4) Taping Method

- ① Tapes for capacitors are wound clockwise. The sprocket holes are to the right as the tape is pulled toward the user.
- ② Part of the leader and part of the empty tape shall be attached to the end of the tape as follows.
- ③ The top tape and base tape are not attached at the end of the tape for a minimum of 5 pitches.
- ④ Missing capacitors number within 0.1% of the number per reel or 1 pc, whichever is greater, and are not continuous.
- ⑤ The top tape and bottom tape shall not protrude beyond the edges of the tape and shall not cover sprocketed holes.
- ⑥ Cumulative tolerance of sprocket holes, 10 pitches : ±0.3mm.
- ⑦ Peeling off force : 0.1 to 0.6N\* in the direction shown below. \*GRM33:0.05 to 0.5N

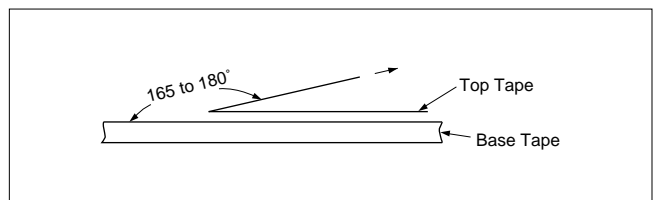
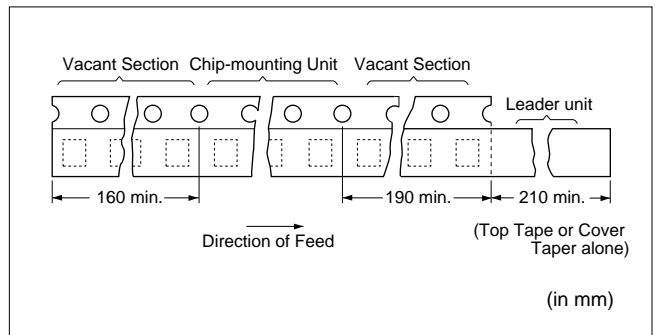

Continued on the following page. ↗

## Package

 Continued from the preceding page.

### ■ Dimensions of Bulk Case Packaging

The bulk case used antistatic materials. Please contact Murata for details.

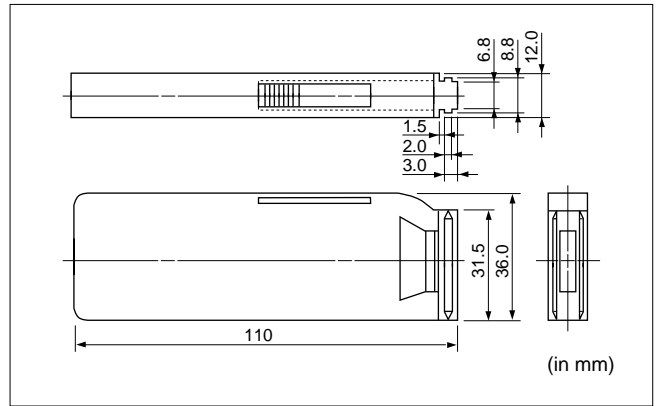

DataSheet4U.com

U.com

DataShee

ataSheet4U.com

www.DataSheet4U.com

## Notice

### ■ Storage and Operating Conditions

Chip monolithic ceramic capacitors (chips) can experience degradation of termination solderability when subjected to high temperature or humidity, or if exposed to sulfur or chlorine gases.

(Reference Data 1. Solderability)

### ■ Rating

Die Bonding/Wire Bonding (GM Series)

(1) Die Bonding of Capacitors

- Use the following materials
  - Braze alloy : Au-Si (98/2) 400 to 420D in N<sub>2</sub> atmosphere
  - Au-Sn (80/20) 300 to 320D in N<sub>2</sub> atmosphere
  - Au-Ge (88/12) 380 to 400D in N<sub>2</sub> atmosphere
- Mounting
  1. Control the temperature of the substrate so that it matches the temperature of the braze alloy.
  2. Place braze alloy on substrate and place the capacitor on the alloy. Hold the capacitor and

gently apply the load. Be sure to complete the operation in 1 minute.

(2) Wire Bonding

- Wire
  - Gold wire : 20mm (0.0008 inch), 25mm (0.001 inch) diameter
- Bonding
  1. Thermocompression, ultrasonic wedge or ball bonding. Required stage temperature : 150 to 250D.
  2. Required wedge or capillary weight : 0.2N to 0.5N.
  3. Bond the capacitor and base substrate or other devices with gold wire.

### ■ Handling

1. Inspection

Thrusting force of the test probe can flex the PCB, resulting in cracked chips or open solder joints. Provide support pins on the back side of the PCB to prevent warping or flexing.

2. Board Separation (or Depanelization)

- Board flexing at the time of separation causes cracked chips or broken solder.
- Severity of stresses imposed on the chip at the time of board break is in the order of : PushbackFSlitterFV SlotFPerforator.
- Board separation must be performed using special jigs, not with hands.

DataSheet4U.com

### ■ Others

1. Resin Coating

When selecting resin materials, select those with low contraction.

2. Circuit Design

These capacitors on this catalog are not safety recognized products

3. Remarks

The above notices are for standard applications and conditions. Contact us when the products are used in special mounting conditions. Select optimum conditions for operation as they determine the reliability of the product after assembly. The data here in are given in typical values, not guaranteed ratings.

et4U.com

DataShee

# Notice

## ■ Soldering and Mounting

### 1. PCB Design

#### (1) Notice for Pattern Forms

Unlike leaded components, chip components are susceptible to flexing stresses since they are mounted directly on the substrate.

They are also more sensitive to mechanical and thermal stresses than leaded components.

Excess solder fillet height can multiply these stresses and cause chip cracking. When designing substrates, take land patterns and dimensions into consideration to eliminate the possibility of excess solder fillet height.

#### Pattern Forms

	Placing Close to Chassis	Placing of Chip Components and Leaded Components	Placing of Leaded Components after Chip Component	Lateral Mounting
Incorrect				
Correct				

Continued on the following page.

## Notice

 Continued from the preceding page.

## (2) Land Dimensions

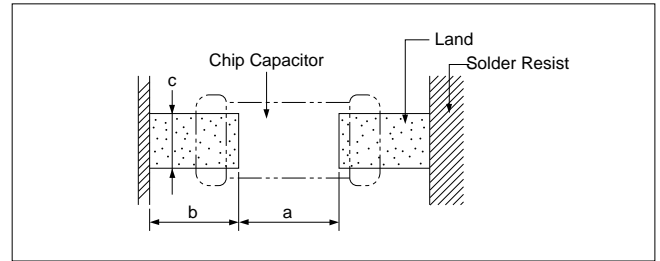

Table 1 Flow Soldering Method

Part Number	Dimensions (L×W)	a	b	c
GRM39 GRM420 GRQ706	1.6×0.8	0.6–1.0	0.8–0.9	0.6–0.8
GRM40 GRM425 GRQ708	2.0×1.25	1.0–1.2	0.9–1.0	0.8–1.1
GRM42-6 GRM430	3.2×1.6	2.2–2.6	1.0–1.1	1.0–1.4
LL0508	1.25×2.0	0.4–0.7	0.5–0.7	1.4–1.8
LL0612	1.6×3.2	0.6–1.0	0.8–0.9	2.6–2.8
GRH706	1.25×1.0	0.4–0.6	0.6–0.8	0.8–1.0
GRH708	2.0×1.25	1.0–1.2	0.9–1.0	0.8–1.0
GRH110	1.4×1.4	0.5–0.8	0.8–0.9	1.0–1.2

(in mm)

Table 2 Reflow Soldering Method

Part Number	Dimensions (L×W)	a	b	c
GRM33	0.6×0.3	0.2–0.3	0.2–0.35	0.2–0.4
GRM36 GRM615	1.0×0.5	0.3–0.5	0.35–0.45	0.4–0.6
GRM39 GRM420 GRQ706	1.6×0.8	0.6–0.8	0.6–0.7	0.6–0.8
GRM40 GRM425 GRQ708	2.0×1.25	1.0–1.2	0.6–0.7	0.8–1.1
GRM42-6 GRM430	3.2×1.6	2.2–2.4	0.8–0.9	1.0–1.4
GRM42-2 GRM435	3.2×2.5	2.0–2.4	1.0–1.2	1.8–2.3
GRM43-2	4.5×3.2	3.0–3.5	1.2–1.4	2.3–3.0
GRM44-1	5.7×5.0	4.0–4.6	1.4–1.6	3.5–4.8
LL0306	0.8×1.6	0.2–0.4	0.3–0.4	1.0–1.4
LL0508	1.25×2.0	0.4–0.6	0.3–0.5	1.4–1.8
LL0612	1.6×3.2	0.6–0.8	0.6–0.7	2.6–2.8
GRH706	1.25×1.0	0.4–0.6	0.6–0.8	0.8–1.0
GRH708	2.0×1.25	1.0–1.2	0.6–0.8	0.8–1.0
GRH710	3.2×2.5	2.2–2.5	0.8–1.0	1.9–2.3
GRH110	1.4×1.4	0.4–0.8	0.6–0.8	1.0–1.2
GRH111	2.8×2.8	1.8–2.1	0.7–0.9	2.2–2.6
GR530	4.5×3.8	3.2–3.4	0.9–1.2	3.0–3.8
GR535	5.6×5.0	4.2–4.5	0.9–1.2	4.0–5.0
GR540	10.6×5.0	8.5–9.0	1.3–1.5	4.0–5.0
GR545	10.6×10.0	8.5–9.0	1.3–1.5	8.0–10.0
GR550	11.8×10.6	9.0–9.5	1.8–2.0	8.0–10.0
GR555	16.0×5.0	13.0–13.5	1.8–2.0	4.0–5.0
GR580	28.1×13.2	25.0–25.5	2.2–2.4	10.0–12.0

(in mm)

Continued on the following page. 

# Notice

Continued from the preceding page.

● GNM Series for reflow soldering method

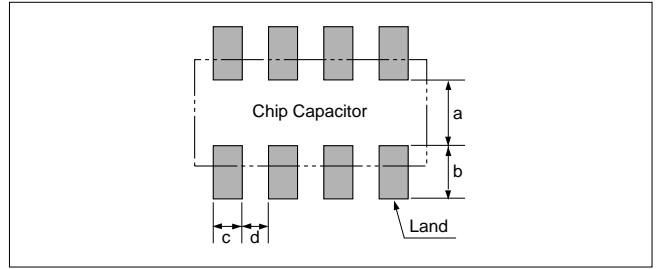
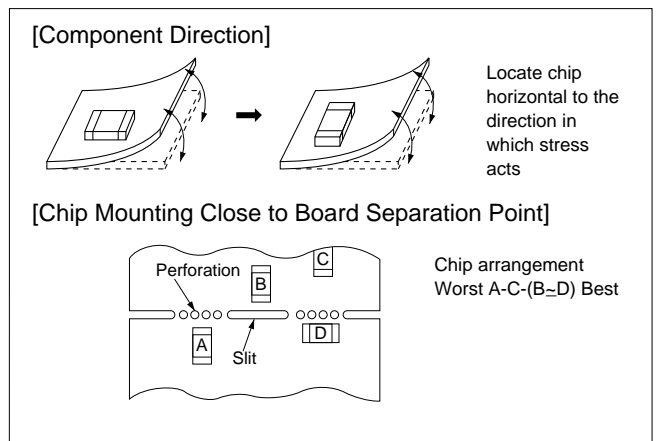

Table 3

Part Number	Dimensions (mm)					
	L	W	a	b	c	d
<b>GNM30-401</b>	3.2	1.6	0.8–1.0	0.7–0.9	0.3–0.4	0.4–0.5

(3) Mounting Position

Choose a mounting position that minimizes the stress imposed on the chip during flexing or bending of the board.



(Reference Data 2. Board bending strength for solder fillet height)  
 (Reference Data 3. Temperature cycling for solder fillet height)  
 (Reference Data 4. Board bending strength for board material)

## 2. Solder Paste Printing

- Overly thick application of solder paste results in excessive fillet height solder. This makes the chip more susceptible to mechanical and thermal stress on the board and may cause cracked chips.
- Too little solder paste results in a lack of adhesive strength on the outer electrode, which may result in chips breaking loose from the PCB.
- Make sure the solder has been applied smoothly to the end surface to a height of 0.2mm min.

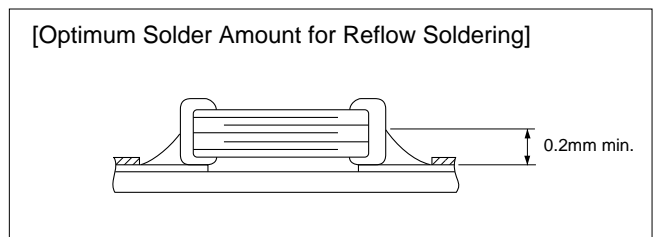

Continued on the following page. ↗

Continued from the preceding page.

### 3. Chip Placing

- An excessively low bottom dead point of the suction nozzle imposes great force on the chip during mounting, causing cracked chips. So adjust the suction nozzle's bottom dead point by correcting warp in the board. Normally, the suction nozzle's bottom dead point must be set on the upper surface of the board. Nozzle pressure for chip mounting must be a 1 to 3N static load.
- Dirt particles and dust accumulated between the suction nozzle and the cylinder inner wall prevent the nozzle from moving smoothly. This imposes great force on the chip during mounting, causing cracked chips. And the locating claw, when worn out, imposes uneven forces on the chip when positioning, causing cracked chips. The suction nozzle and the locating claw must be maintained, checked and replaced periodically.  
(Reference Data 5. Break strength)

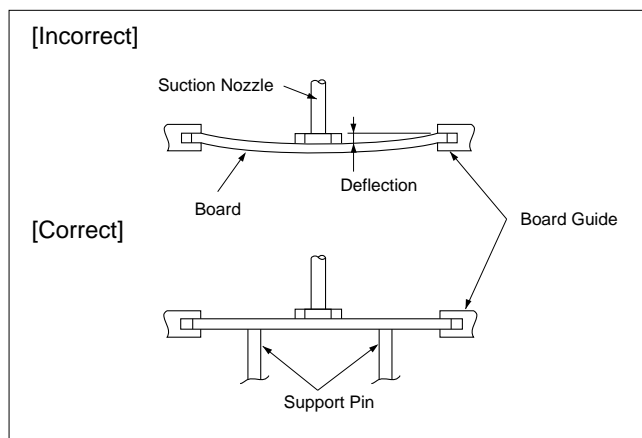

### 4. Reflow Soldering

- Sudden heating of the chip results in distortion due to excessive expansion and construction forces within the chip causing cracked chips. So when preheating, keep temperature differential,  $\Delta T$ , within the range shown in Table 4. The smaller the  $\Delta T$ , the less stress on the chip.
- When components are immersed in solvent after mounting, be sure to maintain the temperature difference ( $\Delta T$ ) between the component and solvent within the range shown in the above table.

Table 4

Part Number	Temperature Differential
GRM33/36/39/40/42-6 GRM420/425/430/615 LL0306/0508/0612 GRH706/708/110 GRQ706/708	$\Delta T \leq 190^\circ\text{C}$
GRM42-2/43-2/44-1/435 GNM30-401 GRH710/111 GR530/535/540/545/550/555/580	$\Delta T \leq 130^\circ\text{C}$

#### [Standard Conditions for Reflow Soldering]

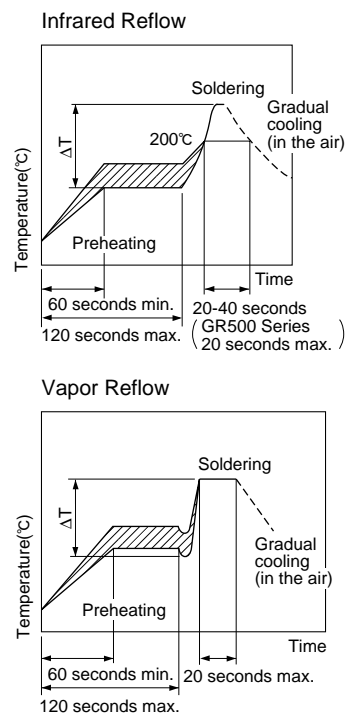

#### [Allowable Soldering Temperature and Time]

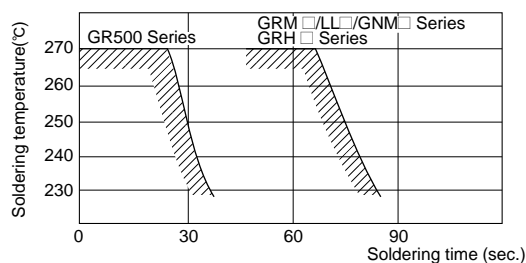

In case of repeated soldering, the accumulated soldering time must be within the range shown above.

#### Inverting the PCB

Make sure not to impose an abnormal mechanical shock on the PCB.

Continued on the following page.



## Notice

Continued from the preceding page.

### 5. Adhesive Application

- Thin or insufficient adhesive causes chips to loosen or become disconnected when flow soldered. The amount of adhesive must be more than dimension C shown in the drawing below to obtain enough bonding strength. The chip's electrode thickness and land thickness must be taken into consideration.
- Low viscosity adhesive causes chips to slip after mounting. Adhesive must have a viscosity of 5000pa-s (500ps)min. (at 25°C)

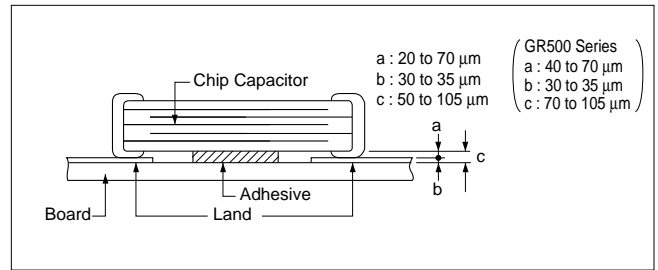

### 6. Adhesive Curing

Insufficient curing of the adhesive causes chips to disconnect during flow soldering and causes deteriorated insulation resistance between outer electrodes due to moisture absorption. Control curing temperature and time in order to prevent insufficient hardening.

### Inverting the PCB

Make sure not to impose an abnormal mechanical shock on the PCB.

### 7. Leaded Component Insertion

If the PCB is flexed when leaded components (such as transformers and ICs) are being mounted, chips may crack and solder joints may break. Before mounting leaded components, support the PCB using backup pins or special jigs to prevent warping.

### 8. Flux Application

- An excessive amount of flux generates a large quantity of flux gas, causing deteriorated solderability. So apply flux thinly and evenly throughout. (A foaming system is generally used for flow soldering).
- Flux containing too high a percentage of halide may cause corrosion of the outer electrodes unless sufficiently cleaned. Use flux with a halide content of 0.2wt% max. But do not use strongly acidic flux. Wash thoroughly because water soluble flux causes deteriorated insulation resistance between outer electrodes unless sufficiently cleaned.

Continued on the following page.

Continued from the preceding page.

### 9. Flow Soldering

- Sudden heating of the chip results in thermal distortion causing cracked chips. And an excessively long soldering time or high soldering temperature results in leaching of the outer electrodes, causing poor adhesion or a reduction in capacitance value due to loss of contact between electrodes and end termination.
- When preheating, keep the temperature differential between solder temperature and chip surface temperature,  $\Delta T$ , within the range shown in Table 5. The smaller the  $\Delta T$ , the less stress on the chip. When components are immersed in solvent after mounting, be sure to maintain the temperature difference between the component and solvent within the range shown in Table 5. Do not apply flow soldering to chips not listed in Table 5.

Table 5

Part Number	Temperature Differential
GRM39/40/42-6	$\Delta T \leq 150^\circ\text{C}$
GRM420/425/430	
LL0508/0612	
GRH706/708/110	
GRQ706/708	

#### ● Optimum Solder Amount for Flow Soldering

- Set temperature and time to ensure that leaching of the outer electrode does not exceed 25% of the chip end area as a single chip (full length of the edge A-B-C-D shown below) and 25% of the length A-B shown below as mounted on substrate.

(Reference Data 6. Thermal shock)  
 (Reference Data 7. Solder heat resistance)

[Standard Conditions for Flow Soldering]

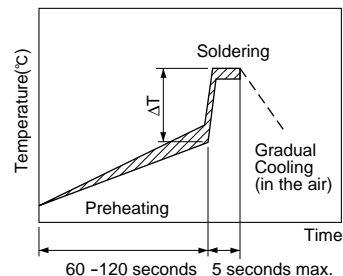

[Allowable Soldering Temperature and Time]

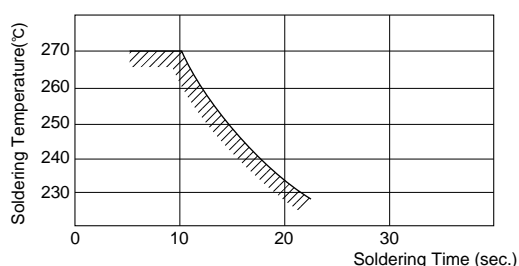

In case of repeated soldering, the accumulated soldering time must be within the range shown above.

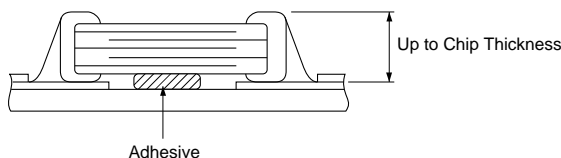

[As a Single Chip]

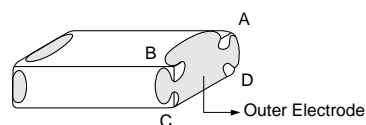

[As Mounted on Substrate]

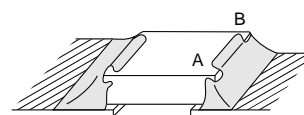

Continued on the following page. ↗

## Notice

Continued from the preceding page.

### 10. Correction with a Soldering Iron

(1) For Chip Type Capacitors

- Sudden heating of the chip results in distortion due to a high internal temperature differential, causing cracked chips. When preheating, keep temperature differential,  $\Delta T$ , within the range shown in Table 6. The smaller the  $\Delta T$ , the less stress on the chip.

Table 6

Part Number	Temperature Differential
GRM36/39/40/42-6 GRM420/425/430/615 LL0306/0508/0612 GRQ706/708 GRH706/708/110	$\Delta T \leq 190^\circ\text{C}$
GRM42-2/43-2/44-1/435 GNM30-401 GRH710/111 GR530/535/540/545/550/555/580	$\Delta T \leq 130^\circ\text{C}$

[Standard Conditions for Soldering Iron Temperature]

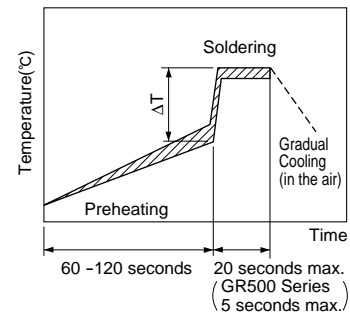

[Allowable Time and Temperature for Making Corrections with a Soldering Iron]

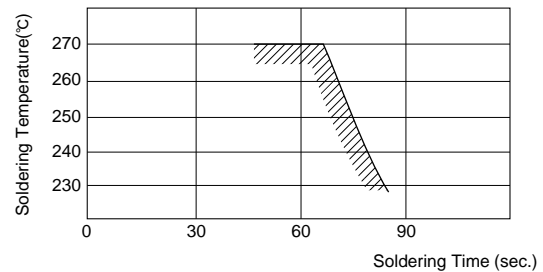

The accumulated soldering Time / temperature including reflow / flow soldering must be within the range shown above.

- Optimum Solder Amount when Corrections Are Made Using a Soldering Iron

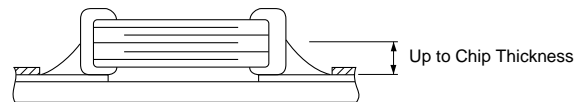

- When correcting chips with a soldering iron, no preheating is required if the chip is listed in Table 7 and the following conditions (Table 7) are met.

Preheating should be performed on chips not listed in Table 7.

(Reference Data 8. Thermal shock when making a correction with a soldering iron)

Table 7 Correction with a Soldering Iron

Part Number	Temperature of Iron Tip	Soldering Iron Wattage	Diameter of Iron Tip	Restriction
GRM36/39/40 GRM420/425/615 LL0306/0508 GRQ706/708 GRH706/708/110	300°C max.	20W max.	$\phi$ 3mm max.	Do not allow the iron tip to directly touch the ceramic element.
GRM42-6 GRM430 LL0612 GNM30-401	270°C max.			

www.DataSheet4U.com

Continued on the following page.

 Continued from the preceding page.

(2) For Microstrip Types

- Solder 1mm away from the ribbon terminal base, being careful that the solder tip does not directly contact the capacitor. Preheating is unnecessary.
- Complete soldering within 3 seconds with a soldering tip less than 270D in temperature.

## 11. Washing

Excessive output of ultrasonic oscillation during cleaning causes PCBs to resonate, resulting in cracked chips or broken solder. Take note not to vibrate PCBs.

## Reference Data

### 1. Solderability

#### (1) Test Method

Subject the chip capacitor to the following conditions.  
Then apply flux (a ethanol solution of 25% rosin) to the chip and dip it in 230°C eutectic solder for 2 seconds.

Conditions :

Expose prepared at room temperature (for 6 months and 12 months, respectively)

Prepared at high temperature (for 100 hours at 85°C)

Prepared left at high humidity (for 100 hours under 90%RH to 95%RH at 40°C)

#### (2) Test Samples

GRM40 : Products for flow/reflow soldering.

#### (3) Acceptance Criteria

With a 60-power optical microscope, measure the surface area of the outer electrode that is covered with solder.

#### (4) Results

Refer to Table 1.

Table 1

Sample	Initial State	Prepared at Room Temperature		Prepared at High Temperature for 100 Hours at 85°C	Prepared at High Humidity for 100 Hours at 90 to 95% RH and 40°C
		6 months	12 months		
GRM40 for flow/reflow soldering	95 to 100%	95 to 100%	95%	90 to 95%	95%

### 2. Board Bending Strength for Solder Fillet Height

#### (1) Test Method

Solder the chip capacitor to the test PCB with the amount of solder paste necessary to achieve the fillet heights.

Then bend the PCB using the method illustrated and measure capacitance.

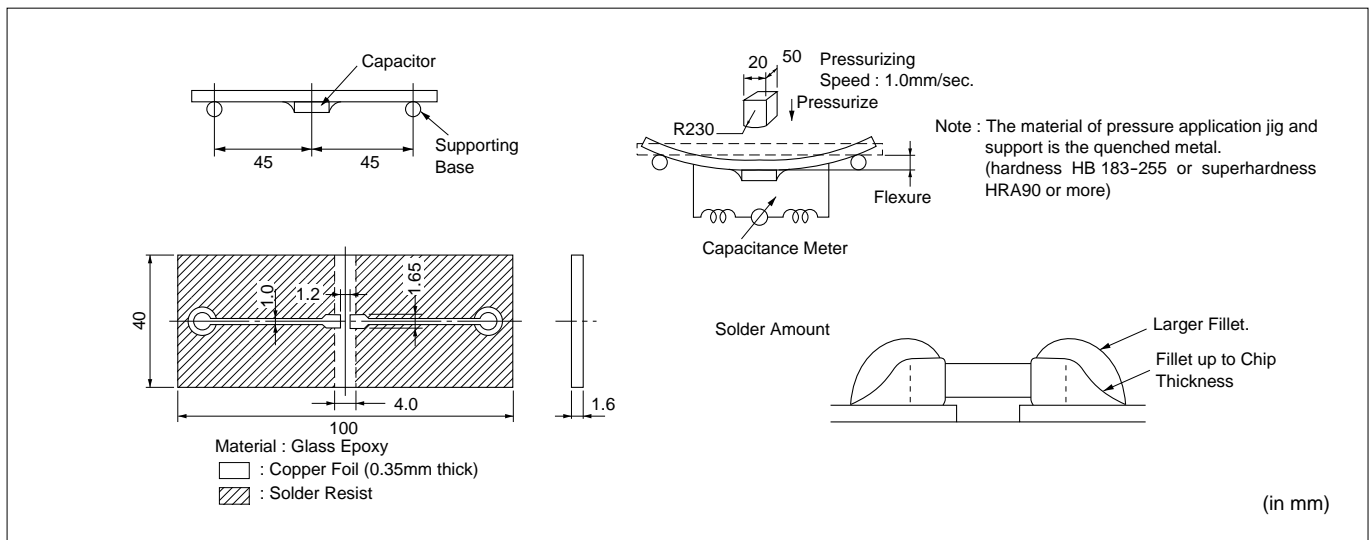

#### (2) Test Samples

GRM40 C0G/X7R/Y5V Characteristics T=0.6mm

#### (3) Acceptance Criteria

Products shall be determined to be defective if the change in capacitance has exceeded the values specified in Table 2.

Table 2

Characteristics	Change in Capacitance
<b>C0G</b>	Within $\pm 5\%$ or $\pm 0.5\text{pF}$ , whichever is greater
<b>X7R</b>	Within $\pm 12.5\%$
<b>Y5V</b>	Within $\pm 20\%$

Continued from the preceding page.

(4) Results

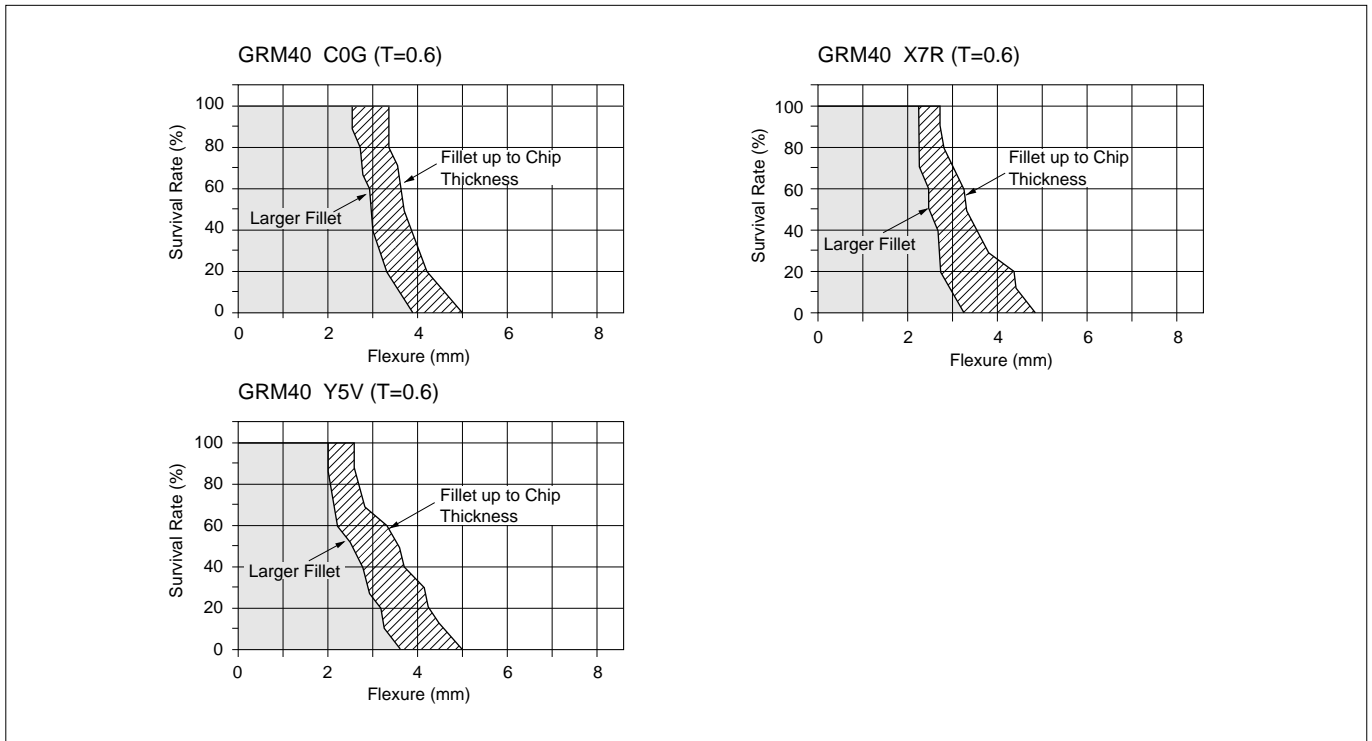

3. Temperature Cycling for Solder Fillet Height

(1) Test Method

Solder the chips to the substrate various test fixtures using sufficient amounts of solder to achieve the required fillet height. Then subject the fixtures to the cycle illustrated below 200 times.

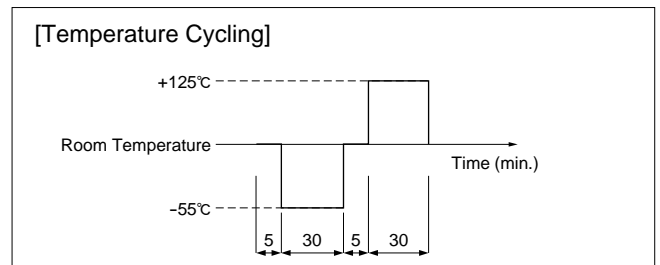

① Solder Amount

Alumina substrates are typically designed for reflow soldering. Glass epoxy or paper phenol substrates are typically used for flow soldering.

② Material

- Alumina (Thickness : 0.64mm)
- Glass epoxy (Thickness : 1.6 mm)
- Paper phenol (Thickness : 1.6 mm)

[Solder Amount]

Substrate		Alumina	Glass Epoxy or Paper Phenol
Solder Amount	①		
	②		
	③		
Solder to be used		6X4 Eutectic solder	

③ Land Dimension

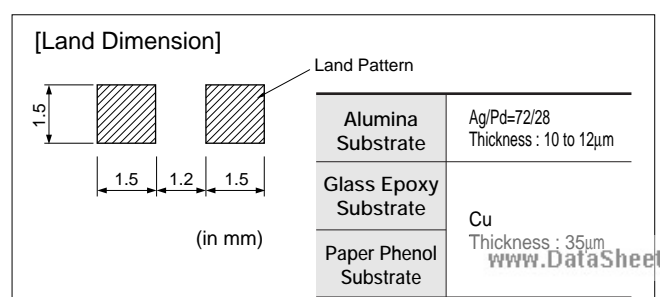

Continued on the following page.

# Reference Data

Continued from the preceding page.

## (2) Test Samples

GRM40 C0G/X7R/Y5V Characteristics T=0.6mm

## (3) Acceptance Criteria

Products shall be determined to be defective if the change in capacitance has exceeded the values specified in Table 3.

Table 3

Characteristics	Change in Capacitance
<b>C0G</b>	Within $\pm 2.5\%$ or $\pm 0.25\text{pF}$ , whichever is greater
<b>X7R</b>	Within $\pm 7.5\%$
<b>Y5V</b>	Within $\pm 20\%$

## (4) Results

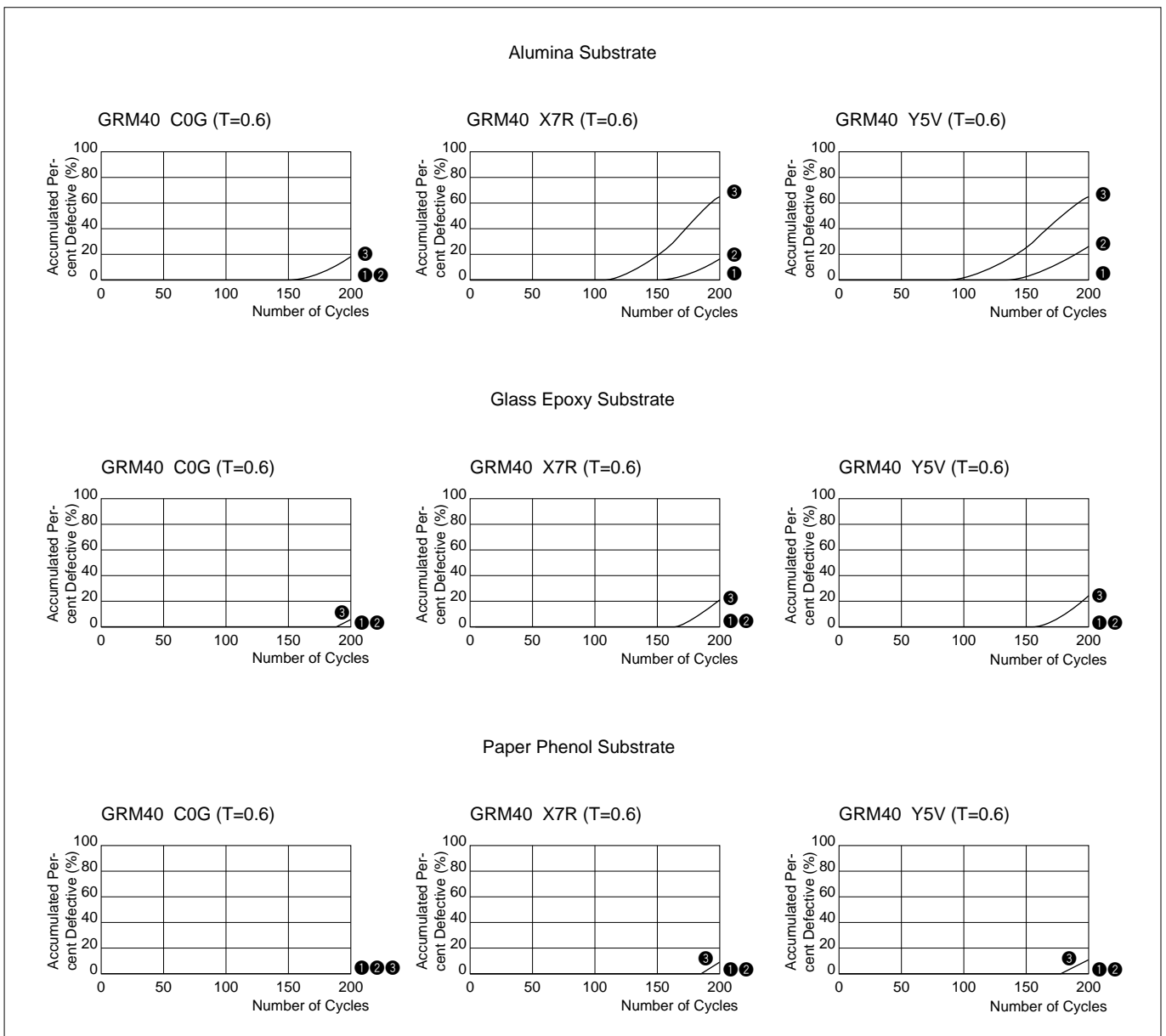

Continued on the following page.

Continued from the preceding page.

4. Board Bending Strength for Board Material

(1) Test Method

Solder the chip to the test board. Then bend the board using the method illustrated below, as measure capacitance.

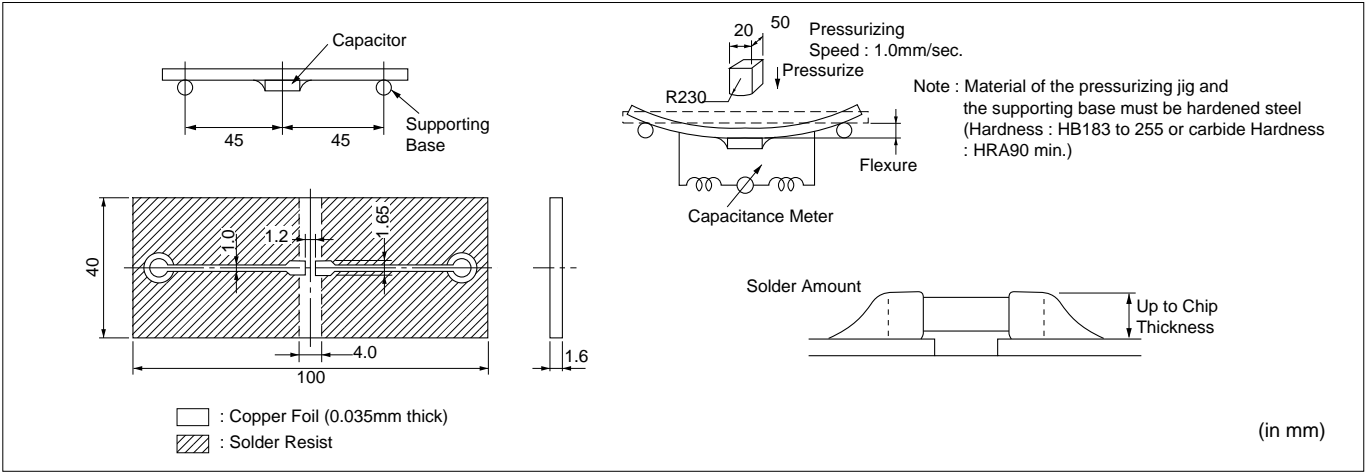

(2) Test Samples

GRM40 C0G/X7R/Y5V Characteristics T=0.6mm typical

(3) Acceptance Criteria

Products shall be determined to be defective if the change in capacitance has exceeded the values specified in Table 4.

Table 4

Characteristics	Change in Capacitance
<b>C0G</b>	Within $\pm 5\%$ or $\pm 0.5\text{pF}$ , whichever is greater
<b>X7R</b>	Within $\pm 12.5\%$
<b>Y5V</b>	Within $\pm 20\%$

(4) Results

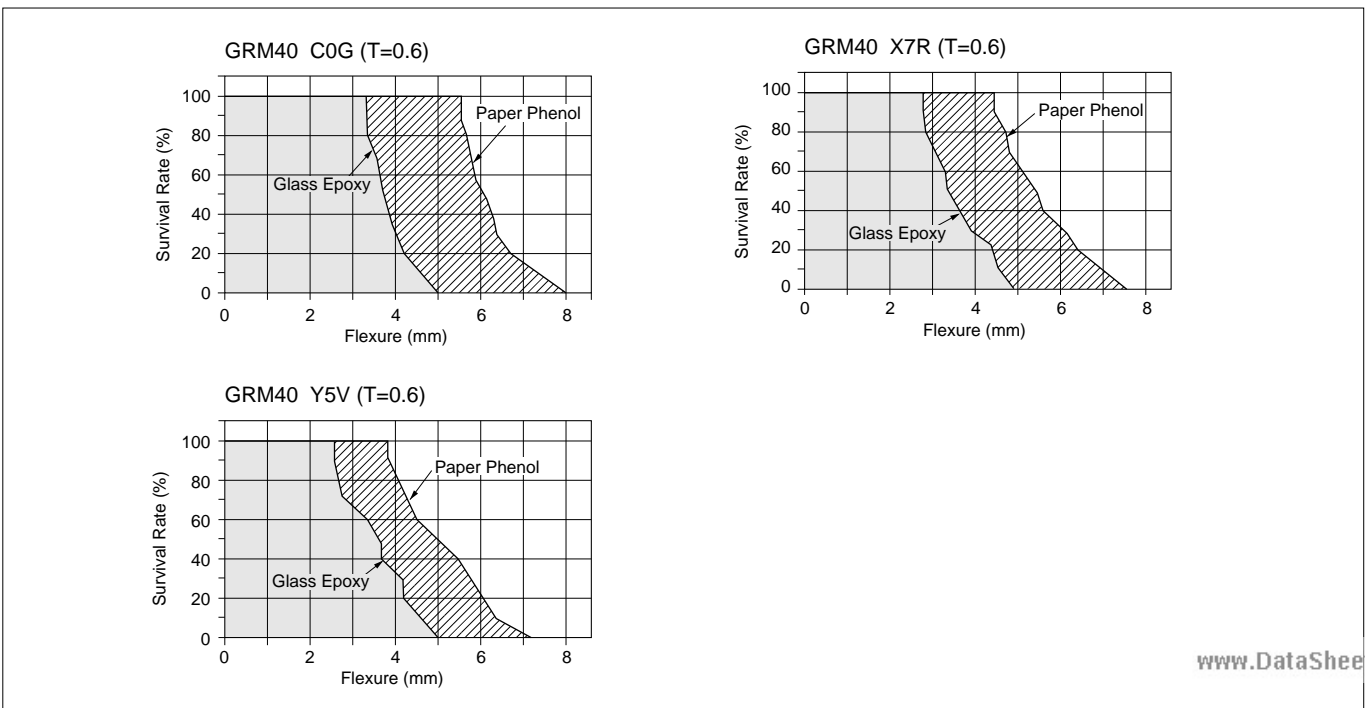



# Reference Data

Continued from the preceding page.

## 5. Break Strength

### (1) Test Method

Place the chip on a steel plate as illustrated on the right. Increase load applied to a point near the center of the test sample.

### (2) Test Samples

GRM40 C0G/X7R/Y5V Characteristics  
GRM42-6 C0G/X7R/Y5V Characteristics

### (3) Acceptance Criteria

Define the load that has caused the chip to break or crack, as the bending force.

### (4) Explanation

Break strength, P, is proportionate to the square of the thickness of the ceramic element and is expressed as a curve of secondary degree.

The formula is :

$$P = \frac{2\gamma WT^2}{3L} \quad (\text{N})$$

- W : Width of ceramic element (mm)
- T : Thickness of element (mm)
- L : Distance between fulcrums (mm)
- $\gamma$  : Bending stress (N/mm<sup>2</sup>)

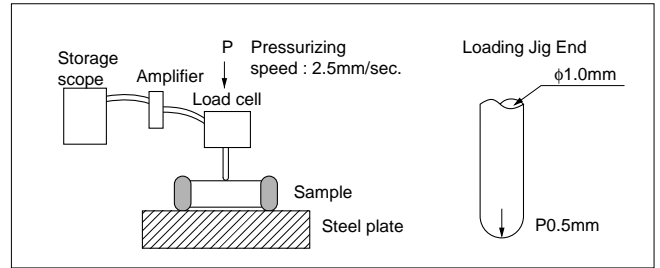

Chip Size	L	W	$\gamma$		
			C0G Characteristics	X7R Characteristics	Y5V Characteristics
<b>GRM40</b>	1.5	1.2	300	180	160
<b>GRM42-6</b>	2.7	1.5			

(in mm)

### (5) Results

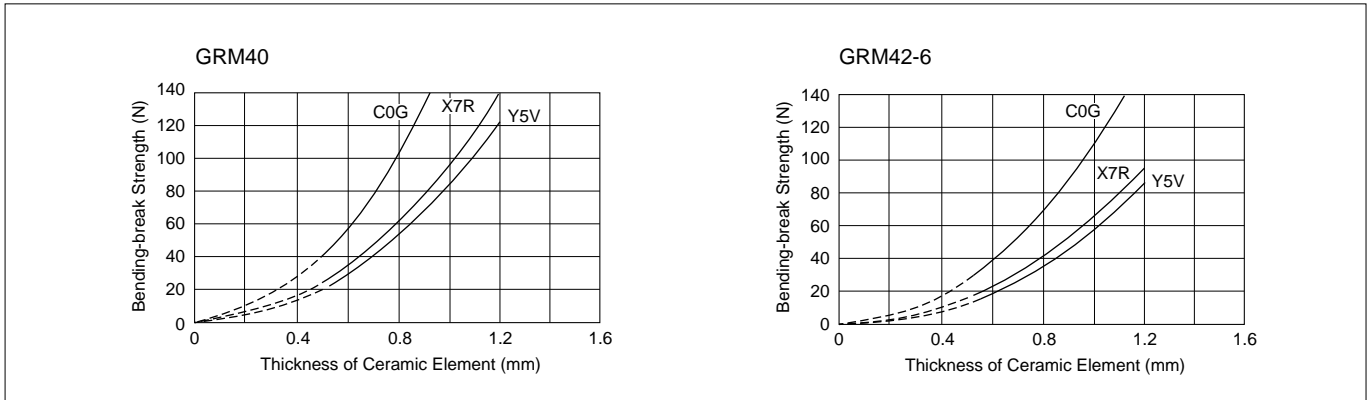

## 6. Thermal Shock

### (1) Test method

After applying flux (an ethanol solution of 25% rosin), dip the chip in a solder bath (6X4 eutectic solder) in accordance with the following conditions :

### (2) Test samples

GRM40 C0G/X7R/Y5V Characteristics T=0.6mm typical

### (3) Acceptance criteria

Visually inspect the test sample with a 60-power optical microscope. Chips exhibiting breaks or cracks shall be determined to be defective.

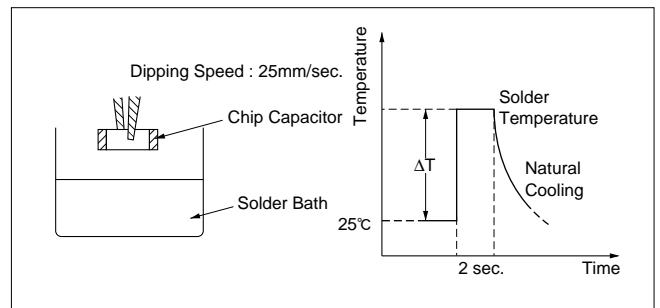

Continued from the preceding page.

(4) Results

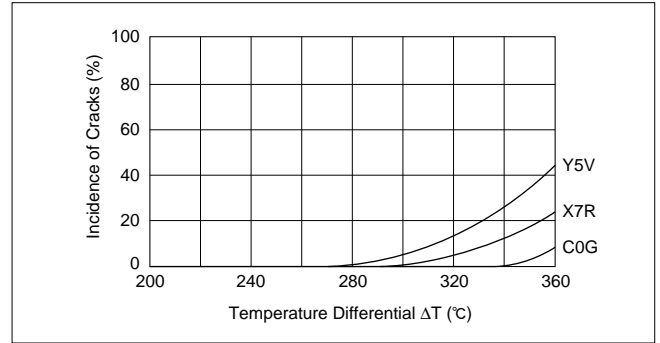

7. Solder Heat Resistance

(1) Test Method

① Reflow soldering :

Apply about 300 μm of solder paste over the alumina substrate. After reflow soldering, remove the chip and check for leaching that may have occurred on the outer electrode.

② Flow soldering :

After dipping the test sample with a pair of tweezers in wave solder (eutectic solder), check for leaching that may have occurred on the outer electrode.

③ Dip soldering :

After dipping the test sample with a pair of tweezers in static solder (eutectic solder), check for leaching that may have occurred on the outer electrode.

④ Flux to be used : An ethanol solution of 25 % rosin.

(2) Test samples

GRM40 : For flow/reflow soldering T=0.6mm

(3) Acceptance criteria

The starting time of leaching shall be defined as the time when the outer electrode has lost 25 % of the total edge length of A-B-C-D as illustrated :

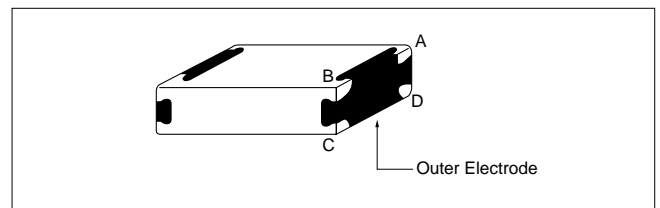

(4) Results

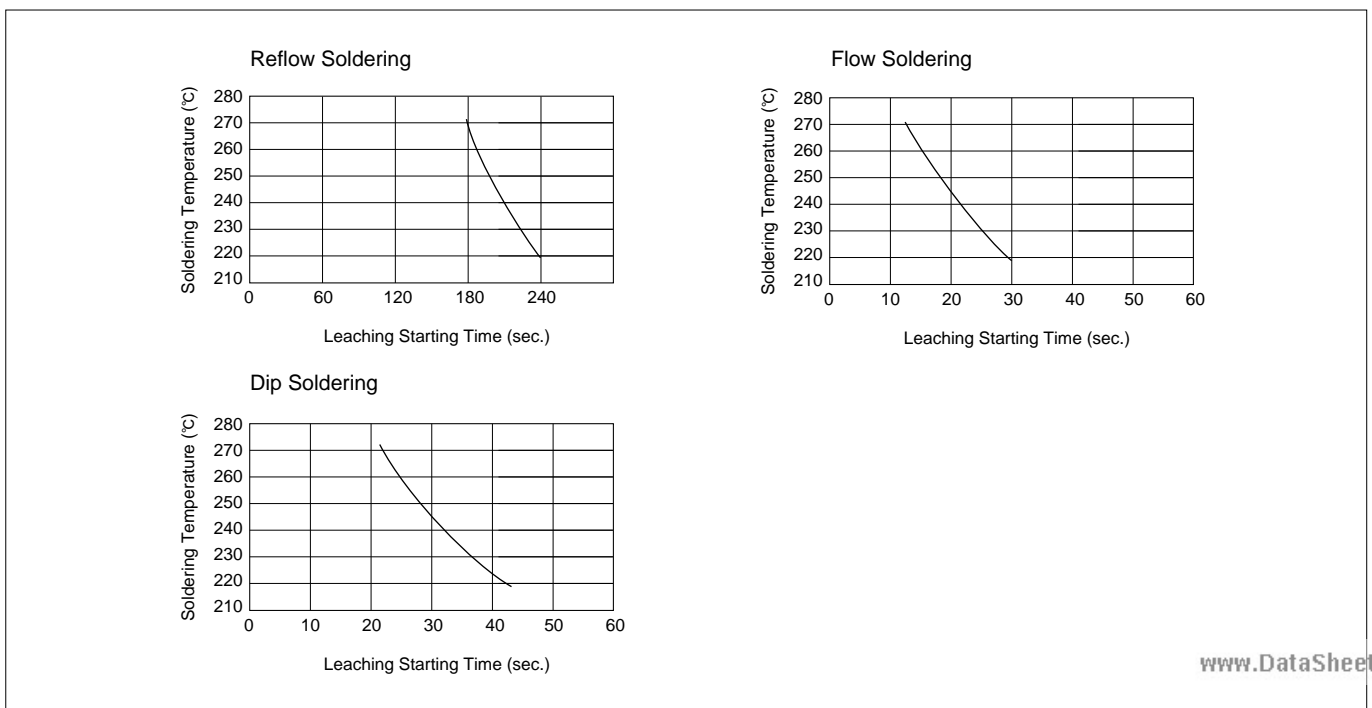

## Reference Data

 Continued from the preceding page.

### 8. Thermal Shock when Making Corrections with a Soldering Iron

#### (1) Test Method

Apply a soldering iron meeting the conditions below to the soldered joint of a chip that has been soldered to a paper phenol board, while supplying wire solder. (Note: the soldering iron tip shall not directly touch the ceramic element of the chip.)

#### (2) Test Samples

GRM40 C0G/X7R/Y5V Characteristics T=0.6mm

#### (3) Acceptance Criteria for Defects

Observe the appearance of the test sample with a 60-power optical microscope. Those units displaying any breaks cracks shall be determined to be defective.

#### (4) Results

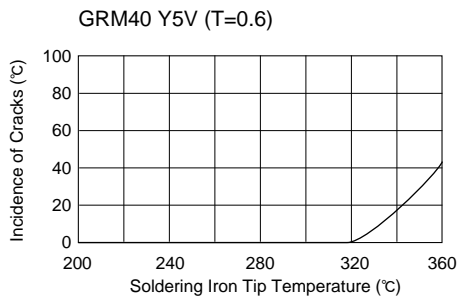
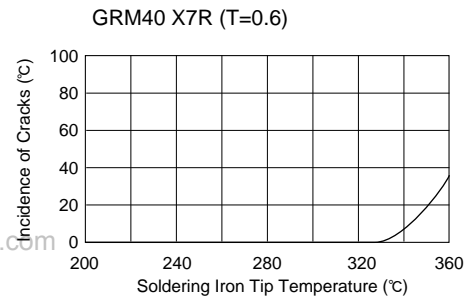
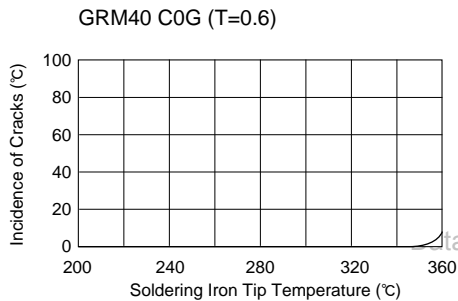
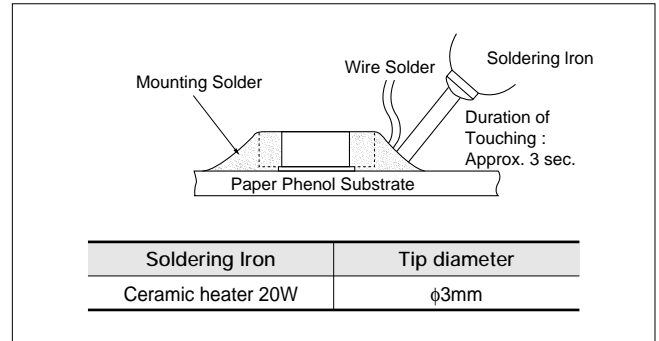

# CHIP MONOLITHIC CERAMIC CAPACITOR

## for High-voltage Low Dissipation Type GHM1000 Series

### ■ Features

1. Murata's original internal electrode structure realizes high Flash-over Voltage.
2. A new monolithic structure for small, surface-mountable devices capable of operating at high-voltage levels.
3. Sn-plated external electrodes allow mounting without silver compound solder.
4. The GHM1030 type for flow and reflow soldering, and other types for reflow soldering.
5. Low-loss and suitable for high-frequency circuits.
6. The temperature characteristics R is high dielectric constant type, and SL is temperature compensating type.

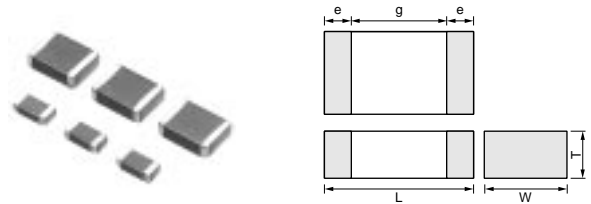

Part Number	Dimensions (mm)				
	L	W	T	e min.	g min.
<b>GHM1030</b>	3.2 ±0.2	1.6 ±0.2	1.0 <sup>+0</sup> <sub>-0.3</sub>	0.3	1.5*
			1.25 <sup>+0</sup> <sub>-0.3</sub>		
<b>GHM1035</b>	3.2 ±0.2	2.5 ±0.2	1.5 <sup>+0</sup> <sub>-0.3</sub>		1.8
<b>GHM1038</b>	4.5 ±0.3	2.0 ±0.2	2.0 ±0.3		2.9
<b>GHM1040</b>	4.5 ±0.3	3.2 ±0.3	2.0 <sup>+0</sup> <sub>-0.3</sub>		
			2.5 <sup>+0</sup> <sub>-0.3</sub>		

\* SL 2kV : 1.8mm min.

### ■ Application

1. Ideal use on high-frequency pulse circuit such as snubber circuit for switching power supply, DC-DC converter, ballast(inverter fluorescent lamp), and so on. (R Characteristics)
2. Ideal for use as the ballast in liquid crystal back lighting inverters. (SL Characteristics)

DataSheet4U.com

Part Number	Rated Voltage (V)	TC Code	Capacitance (pF)	Length L (mm)	Width W (mm)	Thickness T (mm)	Electrode g (mm)	Electrode e (mm)
<b>GHM1030R101K630</b>	DC630	R	100 +10,-10%	3.2	1.6	1.0	1.5 min.	0.3 min.
<b>GHM1030R151K630</b>	DC630	R	150 +10,-10%	3.2	1.6	1.0	1.5 min.	0.3 min.
<b>GHM1030R221K630</b>	DC630	R	220 +10,-10%	3.2	1.6	1.0	1.5 min.	0.3 min.
<b>GHM1030R331K630</b>	DC630	R	330 +10,-10%	3.2	1.6	1.0	1.5 min.	0.3 min.
<b>GHM1030R471K630</b>	DC630	R	470 +10,-10%	3.2	1.6	1.25	1.5 min.	0.3 min.
<b>GHM1030R681K630</b>	DC630	R	680 +10,-10%	3.2	1.6	1.25	1.5 min.	0.3 min.
<b>GHM1030R102K630</b>	DC630	R	1000 +10,-10%	3.2	1.6	1.25	1.5 min.	0.3 min.
<b>GHM1030R470K1K</b>	DC1000	R	47 +10,-10%	3.2	1.6	1.0	1.5 min.	0.3 min.
<b>GHM1030R680K1K</b>	DC1000	R	68 +10,-10%	3.2	1.6	1.0	1.5 min.	0.3 min.
<b>GHM1030R101K1K</b>	DC1000	R	100 +10,-10%	3.2	1.6	1.0	1.5 min.	0.3 min.
<b>GHM1030R151K1K</b>	DC1000	R	150 +10,-10%	3.2	1.6	1.0	1.5 min.	0.3 min.
<b>GHM1030R221K1K</b>	DC1000	R	220 +10,-10%	3.2	1.6	1.0	1.5 min.	0.3 min.
<b>GHM1030R331K1K</b>	DC1000	R	330 +10,-10%	3.2	1.6	1.0	1.5 min.	0.3 min.
<b>GHM1030R471K1K</b>	DC1000	R	470 +10,-10%	3.2	1.6	1.25	1.5 min.	0.3 min.
<b>GHM1030SL100D2K</b>	DC2000	SL	10 +0.5,-0.5pF	3.2	1.6	1.25	1.8 min.	0.3 min.
<b>GHM1030SL120J2K</b>	DC2000	SL	12 +5,-5%	3.2	1.6	1.25	1.8 min.	0.3 min.
<b>GHM1030SL150J2K</b>	DC2000	SL	15 +5,-5%	3.2	1.6	1.25	1.8 min.	0.3 min.
<b>GHM1030SL180J2K</b>	DC2000	SL	18 +5,-5%	3.2	1.6	1.25	1.8 min.	0.3 min.
<b>GHM1030SL220J2K</b>	DC2000	SL	22 +5,-5%	3.2	1.6	1.25	1.8 min.	0.3 min.
<b>GHM1035SL270J2K</b>	DC2000	SL	27 +5,-5%	3.2	2.5	1.5	1.8 min.	0.3 min.
<b>GHM1035SL330J2K</b>	DC2000	SL	33 +5,-5%	3.2	2.5	1.5	1.8 min.	0.3 min.
<b>GHM1035SL390J2K</b>	DC2000	SL	39 +5,-5%	3.2	2.5	1.5	1.8 min.	0.3 min.
<b>GHM1035SL470J2K</b>	DC2000	SL	47 +5,-5%	3.2	2.5	1.5	1.8 min.	0.3 min.
<b>GHM1035SL560J2K</b>	DC2000	SL	56 +5,-5%	3.2	2.5	1.5	1.8 min.	0.3 min.
<b>GHM1035SL680J2K</b>	DC2000	SL	68 +5,-5%	3.2	2.5	1.5	1.8 min.	0.3 min.
<b>GHM1035SL820J2K</b>	DC2000	SL	82 +5,-5%	3.2	2.5	1.5	1.8 min.	0.3 min.
<b>GHM1040SL121J2K</b>	DC2000	SL	120 +5,-5%	4.5	3.2	2.0	2.9 min.	0.3 min.

Continued on the following page.

 Continued from the preceding page.

Part Number	Rated Voltage (V)	TC Code	Capacitance (pF)	Length L (mm)	Width W (mm)	Thickness T (mm)	Electrode g (mm)	Electrode e (mm)
<b>GHM1040SL151J2K</b>	DC2000	SL	150 +5,-5%	4.5	3.2	2.0	2.9 min.	0.3 min.
<b>GHM1040SL181J2K</b>	DC2000	SL	180 +5,-5%	4.5	3.2	2.0	2.9 min.	0.3 min.
<b>GHM1040SL221J2K</b>	DC2000	SL	220 +5,-5%	4.5	3.2	2.0	2.9 min.	0.3 min.
<b>GHM1038SL100D3K</b>	DC3150	SL	10 +0.5,-0.5pF	4.5	2.0	2.0	2.9 min.	0.3 min.
<b>GHM1038SL120J3K</b>	DC3150	SL	12 +5,-5%	4.5	2.0	2.0	2.9 min.	0.3 min.
<b>GHM1038SL150J3K</b>	DC3150	SL	15 +5,-5%	4.5	2.0	2.0	2.9 min.	0.3 min.
<b>GHM1038SL180J3K</b>	DC3150	SL	18 +5,-5%	4.5	2.0	2.0	2.9 min.	0.3 min.
<b>GHM1038SL220J3K</b>	DC3150	SL	22 +5,-5%	4.5	2.0	2.0	2.9 min.	0.3 min.
<b>GHM1038SL270J3K</b>	DC3150	SL	27 +5,-5%	4.5	2.0	2.0	2.9 min.	0.3 min.
<b>GHM1038SL330J3K</b>	DC3150	SL	33 +5,-5%	4.5	2.0	2.0	2.9 min.	0.3 min.
<b>GHM1038SL390J3K</b>	DC3150	SL	39 +5,-5%	4.5	2.0	2.0	2.9 min.	0.3 min.
<b>GHM1038SL470J3K</b>	DC3150	SL	47 +5,-5%	4.5	2.0	2.0	2.9 min.	0.3 min.
<b>GHM1038SL560J3K</b>	DC3150	SL	56 +5,-5%	4.5	2.0	2.0	2.9 min.	0.3 min.
<b>GHM1038SL680J3K</b>	DC3150	SL	68 +5,-5%	4.5	2.0	2.0	2.9 min.	0.3 min.
<b>GHM1038SL820J3K</b>	DC3150	SL	82 +5,-5%	4.5	2.0	2.0	2.9 min.	0.3 min.
<b>GHM1040SL101J3K</b>	DC3150	SL	100 +5,-5%	4.5	3.2	2.5	2.9 min.	0.3 min.

DataSheet4U.com

et4U.com

DataShee

## Specifications and Test Methods

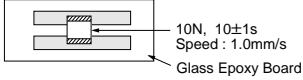
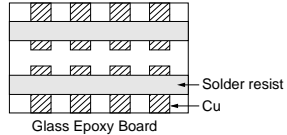
No.	Item	Specification		Test Method												
		Temperature Compensating Type (SL Char.)	High Dielectric Constant Type (R Char.)													
1	Operating Temperature Range	-55 to +125°C														
2	Appearance	No defects or abnormalities.		Visual inspection.												
3	Dimensions	Within the specified dimension.		Using calipers.												
4	Dielectric Strength	No defects or abnormalities.		No failure shall be observed when voltage in Table is applied between the terminations for 1 to 5 s, provided the charge/discharge current is less than 50mA. <table border="1" style="margin-left: auto; margin-right: auto;"> <thead> <tr> <th>Rated voltage</th> <th>Test voltage</th> </tr> </thead> <tbody> <tr> <td>More than DC 1kV</td> <td>120% of the rated voltage</td> </tr> <tr> <td>Less than DC 1kV</td> <td>150% of the rated voltage</td> </tr> </tbody> </table>	Rated voltage	Test voltage	More than DC 1kV	120% of the rated voltage	Less than DC 1kV	150% of the rated voltage						
Rated voltage	Test voltage															
More than DC 1kV	120% of the rated voltage															
Less than DC 1kV	150% of the rated voltage															
5	Insulation Resistance (I.R.)	More than 10,000MΩ		The insulation resistance shall be measured with 500±50V and within 60±5 s of charging.												
6	Capacitance	Within the specified tolerance.		The capacitance/Q/D.F. shall be measured at 20°C at the frequency and voltage shown as follows. (1) Temperature Compensating Type Frequency : 1±0.2MHz Voltage : 0.5 to 5V (r.m.s.) (2) High Dielectric Constant Type Frequency : 1±0.2kHz Voltage : 1±0.2V (r.m.s.)												
7	Q/ Dissipation Factor (D.F.)	C≥30pF : Q≥1,000 C<30pF : Q≥400+20C C : Nominal Capacitance (pF)	D.F.≤0.01													
8	Capacitance Temperature Characteristics	Temp. Coefficient +350 to -1,000 ppm/°C (Temp. Range : +20 to +85°C)	Cap. Change Within ±15%	(1) Temperature Compensating Type The temperature coefficient is determined using the capacitance measured in step 3 as a reference. When cycling the temperature sequentially from step 1 through 5 (+20 to +85 °C) the capacitance shall be within the specified tolerance for the temperature coefficient. <table border="1" style="margin-left: auto; margin-right: auto;"> <thead> <tr> <th>Step</th> <th>Temperature(°C)</th> </tr> </thead> <tbody> <tr> <td>1</td> <td>20±2</td> </tr> <tr> <td>2</td> <td>Min. Operating Temp.±3</td> </tr> <tr> <td>3</td> <td>20±2</td> </tr> <tr> <td>4</td> <td>Max. Operating Temp.±2</td> </tr> <tr> <td>5</td> <td>20±2</td> </tr> </tbody> </table> (2) High Dielectric Constant Type The range of capacitance change compared to the 20°C value within -55 to +125°C shall be within the specified range. •Pretreatment Perform a heat treatment at 150±10 °C for 60±5 min and then let sit for 24±2 h at room condition.	Step	Temperature(°C)	1	20±2	2	Min. Operating Temp.±3	3	20±2	4	Max. Operating Temp.±2	5	20±2
Step	Temperature(°C)															
1	20±2															
2	Min. Operating Temp.±3															
3	20±2															
4	Max. Operating Temp.±2															
5	20±2															
9	Adhesive Strength of Termination	No removal of the terminations or other defect shall occur.		Solder the capacitor to the testing jig (glass epoxy board) shown in Fig.1 using a eutectic solder. Then apply 10N force in the direction of the arrow. The soldering shall be done either with an iron or using the reflow method and shall be conducted with care so that the soldering is uniform and free of defects such as heat shock.  Fig.1												
10	Vibration Resistance	Appearance	No defects or abnormalities.		Solder the capacitor to the test jig (glass epoxy board). The capacitor shall be subjected to a simple harmonic motion having a total amplitude of 1.5mm, the frequency being varied uniformly between the approximate limits of 10 and 55Hz. The frequency range, from 10 to 55Hz and return to 10Hz, shall be traversed in approximately 1 min. This motion shall be applied for a period of 2 h in each 3 mutually perpendicular directions (total of 6 h). 											
		Capacitance	Within the specified tolerance.													
	Q/D.F.	30pF min. : Q≥1,000 30pF max. : Q≥400+20C C : Nominal Capacitance (pF)	D.F.≤0.01													

"Room condition" Temperature : 15 to 35°C, Relative humidity : 45 to 75%, Atmosphere pressure : 86 to 106kPa

Continued on the following page.

## Specifications and Test Methods

Continued from the preceding page.

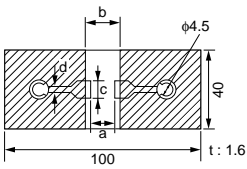
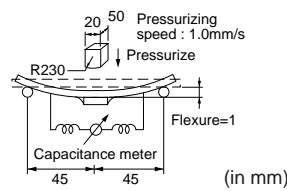
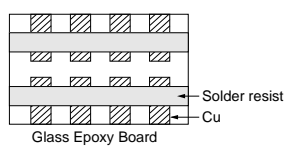
No.	Item	Specification		Test Method																										
		Temperature Compensating Type (SL Char.)	High Dielectric Constant Type (R Char.)																											
11	Deflection	No cracking or marking defects shall occur.		<p>Solder the capacitor to the testing jig (glass epoxy board) shown in Fig.2 using a eutectic solder.</p> <p>Then apply a force in the direction shown in Fig.3.</p> <p>The soldering shall be done either with an iron or using the reflow method and shall be conducted with care so that the soldering is uniform and free of defects such as heat shock.</p>  <table border="1" data-bbox="367 593 877 750"> <thead> <tr> <th rowspan="2">L×W (mm)</th> <th colspan="4">Dimension (mm)</th> </tr> <tr> <th>a</th> <th>b</th> <th>c</th> <th>d</th> </tr> </thead> <tbody> <tr> <td>3.2×1.6</td> <td>2.2</td> <td>5.0</td> <td>2.0</td> <td rowspan="4">1.0</td> </tr> <tr> <td>3.2×2.5</td> <td>2.2</td> <td>5.0</td> <td>2.9</td> </tr> <tr> <td>4.5×2.0</td> <td>3.5</td> <td>7.0</td> <td>2.4</td> </tr> <tr> <td>4.5×3.2</td> <td>3.5</td> <td>7.0</td> <td>3.7</td> </tr> </tbody> </table> <p style="text-align: center;">Fig.2</p>  <p style="text-align: center;">Fig.3</p>	L×W (mm)	Dimension (mm)				a	b	c	d	3.2×1.6	2.2	5.0	2.0	1.0	3.2×2.5	2.2	5.0	2.9	4.5×2.0	3.5	7.0	2.4	4.5×3.2	3.5	7.0	3.7
		L×W (mm)	Dimension (mm)																											
a	b		c	d																										
3.2×1.6	2.2	5.0	2.0	1.0																										
3.2×2.5	2.2	5.0	2.9																											
4.5×2.0	3.5	7.0	2.4																											
4.5×3.2	3.5	7.0	3.7																											
12	Solderability of Termination	75% of the terminations are to be soldered evenly and continuously.		<p>Immerse the capacitor in a solution of ethanol (JIS-K-8101) and rosin (JIS-K-5902) (25% rosin in weight proportion). Immerse in eutectic solder solution for <math>2\pm 0.5</math> s at <math>235\pm 5^\circ\text{C}</math>.</p> <p>Immersing speed : <math>25\pm 2.5\text{mm/s}</math></p>																										
13	Resistance to Soldering Heat	Appearance	No marking defects.		<p>Preheat the capacitor at <math>120</math> to <math>150^\circ\text{C}</math>* for 1 min.</p> <p>Immerse the capacitor in eutectic solder solution at <math>260\pm 5^\circ\text{C}</math> for <math>10\pm 1</math> s. Let sit at room condition for <math>24\pm 2</math> h, then measure.</p> <p>•Immersing speed : <math>25\pm 2.5\text{mm/s}</math></p> <p>•Pretreatment for high dielectric constant type</p> <p>Perform a heat treatment at <math>150\pm 0.5^\circ\text{C}</math> for <math>60\pm 5</math> min and then let sit for <math>24\pm 2</math> h at room condition.</p> <p>*Preheating for more than <math>3.2\times 2.5\text{mm}</math></p> <table border="1" data-bbox="933 1108 1452 1198"> <thead> <tr> <th>Step</th> <th>Temperature</th> <th>Time</th> </tr> </thead> <tbody> <tr> <td>1</td> <td><math>100^\circ\text{C}</math> to <math>120^\circ\text{C}</math></td> <td>1 min.</td> </tr> <tr> <td>2</td> <td><math>170^\circ\text{C}</math> to <math>200^\circ\text{C}</math></td> <td>1 min.</td> </tr> </tbody> </table>	Step	Temperature	Time	1	$100^\circ\text{C}$ to $120^\circ\text{C}$	1 min.	2	$170^\circ\text{C}$ to $200^\circ\text{C}$	1 min.																
		Step	Temperature	Time																										
		1	$100^\circ\text{C}$ to $120^\circ\text{C}$	1 min.																										
		2	$170^\circ\text{C}$ to $200^\circ\text{C}$	1 min.																										
		Capacitance Change	Within $\pm 2.5\%$ or $\pm 0.25\text{pF}$ (Whichever is larger)	Within $\pm 10\%$																										
Q/D.F.	$C\geq 30\text{pF}$ : $Q\geq 1,000$ $C<30\text{pF}$ : $Q\geq 400+20C$ C : Nominal Capacitance (pF)	D.F. $\leq 0.01$																												
I.R.	More than $10,000\text{M}\Omega$																													
Dielectric Strength	Pass the item No.4.																													
14	Temperature Cycle	Appearance	No marking defects.		<p>Fix the capacitor to the supporting jig (glass epoxy board) shown in Fig.4 using a eutectic solder.</p> <p>Perform the five cycles according to the four heat treatments listed in the following table.</p> <p>Let sit for <math>24\pm 2</math> h at room condition, then measure.</p> <table border="1" data-bbox="933 1332 1452 1456"> <thead> <tr> <th>Step</th> <th>Temperature (<math>^\circ\text{C}</math>)</th> <th>Time (min)</th> </tr> </thead> <tbody> <tr> <td>1</td> <td>Min. Operating Temp.<math>\pm 3</math></td> <td><math>30\pm 3</math></td> </tr> <tr> <td>2</td> <td>Room Temp.</td> <td>2 to 3</td> </tr> <tr> <td>3</td> <td>Max. Operating Temp.<math>\pm 2</math></td> <td><math>30\pm 3</math></td> </tr> <tr> <td>4</td> <td>Room Temp.</td> <td>2 to 3</td> </tr> </tbody> </table> <p>•Pretreatment for high dielectric constant type</p> <p>Perform a heat treatment at <math>150\pm 0.5^\circ\text{C}</math> for <math>60\pm 5</math> min and then let sit for <math>24\pm 2</math> h at room condition.</p>  <p style="text-align: center;">Fig.4</p>	Step	Temperature ( $^\circ\text{C}$ )	Time (min)	1	Min. Operating Temp. $\pm 3$	$30\pm 3$	2	Room Temp.	2 to 3	3	Max. Operating Temp. $\pm 2$	$30\pm 3$	4	Room Temp.	2 to 3										
		Step	Temperature ( $^\circ\text{C}$ )	Time (min)																										
		1	Min. Operating Temp. $\pm 3$	$30\pm 3$																										
		2	Room Temp.	2 to 3																										
		3	Max. Operating Temp. $\pm 2$	$30\pm 3$																										
4	Room Temp.	2 to 3																												
Capacitance Change	Within $\pm 2.5\%$ or $\pm 0.25\text{pF}$ (Whichever is larger)	Within $\pm 10\%$																												
Q/D.F.	$C\geq 30\text{pF}$ : $Q\geq 1,000$ $C<30\text{pF}$ : $Q\geq 400+20C$ C : Nominal Capacitance (pF)	D.F. $\leq 0.01$																												
I.R.	More than $10,000\text{M}\Omega$																													
Dielectric Strength	Pass the item No.4.																													
15	Humidity (Steady State)	Appearance	No marking defects.		<p>Sit the capacitor at <math>40\pm 2^\circ\text{C}</math> and relative humidity 90 to 95% for <math>500\pm 24</math> h.</p> <p>Remove and let sit for <math>24\pm 2</math> h at room condition, then measure.</p> <p>•Pretreatment for high dielectric constant type</p> <p>Perform a heat treatment at <math>150\pm 0.8^\circ\text{C}</math> for <math>60\pm 5</math> min and then let sit for <math>24\pm 2</math> h at room condition.</p>																									
		Capacitance Change	Within $\pm 5.0\%$ or $\pm 0.5\text{pF}$ (Whichever is larger)	Within $\pm 10\%$																										
		Q/D.F.	$C\geq 30\text{pF}$ : $Q\geq 350$ $C<30\text{pF}$ : $Q\geq 275+\frac{5}{2}C$ C : Nominal Capacitance (pF)	D.F. $\leq 0.01$																										
		I.R.	More than $1,000\text{M}\Omega$																											
		Dielectric Strength	Pass the item No.4.																											

"Room condition" Temperature :  $15$  to  $35^\circ\text{C}$ , Relative humidity :  $45$  to  $75\%$ , Atmosphere pressure :  $86$  to  $106\text{kPa}$

## Specifications and Test Methods

 Continued from the preceding page.

No.	Item	Specification		Test Method						
		Temperature Compensating Type (SL Char.)	High Dielectric Constant Type (R Char.)							
16	Appearance	No marking defects.		Apply the voltage in following table for $1,000 \pm 4\%$ at maximum operating temperature $\pm 3^\circ\text{C}$ . Remove and let sit for $24 \pm 2$ h at room condition, then measure. The charge/discharge current is less than 50mA. •Pretreatment for high dielectric constant type Apply test voltage for $60 \pm 5$ min at test temperature. Remove and let sit for $24 \pm 2$ h at room condition.						
	Capacitance Change	Within $\pm 3.0\%$ or $\pm 0.3\text{pF}$ (Whichever is larger)	Within $\pm 10\%$							
	Q/D.F.	$C \geq 30\text{pF} : Q \geq 350$ $C < 30\text{pF} : Q \geq 275 + \frac{C}{10}$ C : Nominal Capacitance (pF)	D.F. $\leq 0.02$							
	I.R.	More than $1,000\text{M}\Omega$								
	Dielectric Strength	Pass the item No.4.								
				<table border="1"> <thead> <tr> <th>Rated voltage</th> <th>Test voltage</th> </tr> </thead> <tbody> <tr> <td>More than DC 1kV</td> <td>Rated voltage</td> </tr> <tr> <td>Less than DC 1kV</td> <td>120% of the rated voltage</td> </tr> </tbody> </table>	Rated voltage	Test voltage	More than DC 1kV	Rated voltage	Less than DC 1kV	120% of the rated voltage
Rated voltage	Test voltage									
More than DC 1kV	Rated voltage									
Less than DC 1kV	120% of the rated voltage									

"Room condition" Temperature : 15 to  $35^\circ\text{C}$ , Relative humidity : 45 to 75%, Atmosphere pressure : 86 to  $106\text{kPa}$

DataSheet4U.com

et4U.com

DataShee



# CHIP MONOLITHIC CERAMIC CAPACITOR

## for High-voltage High-capacitance Type GHM1500 Series

### ■ Features

1. A new monolithic structure for small, high-capacitance capable of operating at high-voltage levels.
2. Sn-plated external electrodes allow mounting without silver compound solder.
3. The GHM1525 and GHM1530 type for flow and reflow soldering, and other types for reflow soldering.

### ■ Application

1. Ideal use as hot-cold coupling for DC-DC converter.
2. Ideal use on line filter and ringer detector for telephone, facsimile and modem.
3. Ideal use on diode-snubber circuit for switching power supply.

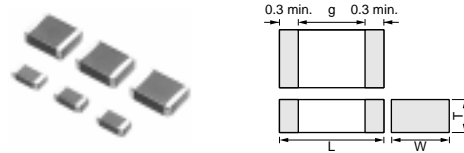

Part Number	Dimensions (mm)			
	L	W	T	g min.
GHM1525	2.0 ±0.2	1.25 ±0.2	1.0 +0,-0.3	0.7
			1.25 ±0.2	
GHM1530	3.2 ±0.2	1.6 ±0.2	1.0 +0,-0.3	1.5
			1.25 +0,-0.3	
			1.6 ±0.2	
GHM1535	3.2 ±0.3	2.5 ±0.2	1.5 +0,-0.3	2.5
			2.0 +0,-0.3	
GHM1540	4.5 ±0.4	3.2 ±0.3	1.5 +0,-0.3	2.5
			2.0 +0,-0.3	
			2.5 +0,-0.3	
			2.6 +0,-0.3	
GHM1545	5.7 ±0.4	5.0 ±0.4	2.0 +0,-0.3	3.5
			2.7 +0,-0.3	

Part Number	Rated Voltage (V)	TC Code	Capacitance	Length L (mm)	Width W (mm)	Thickness T (mm)	Electrode g (mm)	Electrode e (mm)
GHM1525B102K250	DC250	B	1000pF +10,-10%	2.0	1.25	1.0	0.7 min.	0.3 min.
GHM1525B152K250	DC250	B	1500pF +10,-10%	2.0	1.25	1.0	0.7 min.	0.3 min.
GHM1525B222K250	DC250	B	2200pF +10,-10%	2.0	1.25	1.0	0.7 min.	0.3 min.
GHM1525B332K250	DC250	B	3300pF +10,-10%	2.0	1.25	1.0	0.7 min.	0.3 min.
GHM1525B472K250	DC250	B	4700pF +10,-10%	2.0	1.25	1.0	0.7 min.	0.3 min.
GHM1525B682K250	DC250	B	6800pF +10,-10%	2.0	1.25	1.0	0.7 min.	0.3 min.
GHM1525B103K250	DC250	B	10000pF +10,-10%	2.0	1.25	1.25	0.7 min.	0.3 min.
GHM1530B153K250	DC250	B	15000pF +10,-10%	3.2	1.6	1.0	1.5 min.	0.3 min.
GHM1530B223K250	DC250	B	22000pF +10,-10%	3.2	1.6	1.0	1.5 min.	0.3 min.
GHM1530B333K250	DC250	B	33000pF +10,-10%	3.2	1.6	1.25	1.5 min.	0.3 min.
GHM1530B473K250	DC250	B	47000pF +10,-10%	3.2	1.6	1.6	1.5 min.	0.3 min.
GHM1535B683K250	DC250	B	68000pF +10,-10%	3.2	2.5	1.5	1.5 min.	0.3 min.
GHM1535B104K250	DC250	B	0.1μF +10,-10%	3.2	2.5	2.0	1.5 min.	0.3 min.
GHM1540B154K250	DC250	B	0.15μF +10,-10%	4.5	3.2	2.0	2.9 min.	0.3 min.
GHM1540B224K250	DC250	B	0.22μF +10,-10%	4.5	3.2	2.5	2.9 min.	0.3 min.
GHM1545B334K250	DC250	B	0.33μF +10,-10%	5.7	5.0	2.0	3.5 min.	0.3 min.
GHM1545B474K250	DC250	B	0.47μF +10,-10%	5.7	5.0	2.0	3.5 min.	0.3 min.
GHM1530B102K630	DC630	B	1000pF +10,-10%	3.2	1.6	1.25	1.5 min.	0.3 min.
GHM1530B152K630	DC630	B	1500pF +10,-10%	3.2	1.6	1.25	1.5 min.	0.3 min.
GHM1530B222K630	DC630	B	2200pF +10,-10%	3.2	1.6	1.25	1.5 min.	0.3 min.
GHM1530B332K630	DC630	B	3300pF +10,-10%	3.2	1.6	1.25	1.5 min.	0.3 min.
GHM1530B472K630	DC630	B	4700pF +10,-10%	3.2	1.6	1.25	1.5 min.	0.3 min.
GHM1530B682K630	DC630	B	6800pF +10,-10%	3.2	1.6	1.25	1.5 min.	0.3 min.
GHM1530B103K630	DC630	B	10000pF +10,-10%	3.2	1.6	1.25	1.5 min.	0.3 min.
GHM1535B153K630	DC630	B	15000pF +10,-10%	3.2	2.5	1.5	1.5 min.	0.3 min.
GHM1535B223K630	DC630	B	22000pF +10,-10%	3.2	2.5	1.5	1.5 min.	0.3 min.
GHM1540B333K630	DC630	B	33000pF +10,-10%	4.5	3.2	1.5	2.5 min.	0.3 min.
GHM1540B473K630	DC630	B	47000pF +10,-10%	4.5	3.2	1.5	2.5 min.	0.3 min.
GHM1540B683K630	DC630	B	68000pF +10,-10%	4.5	3.2	2.0	2.5 min.	0.3 min.
GHM1540B104K630	DC630	B	0.1μF +10,-10%	4.5	3.2	2.6	2.5 min.	0.3 min.
GHM1545B154K630	DC630	B	0.15μF +10,-10%	5.7	5.0	2.0	3.5 min.	0.3 min.
GHM1545B224K630	DC630	B	0.22μF +10,-10%	5.7	5.0	2.7	3.5 min.	0.3 min.

## Specifications and Test Methods

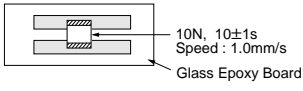
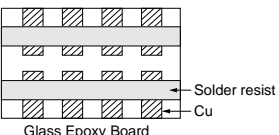
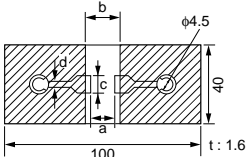
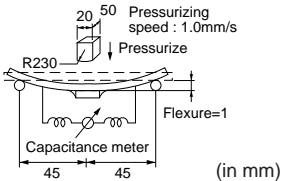
No.	Item	Specification	Test Method																														
1	Operating Temperature Range	-55 to +125°C	-																														
2	Appearance	No defects or abnormalities.	Visual inspection.																														
3	Dimensions	Within the specified dimensions.	Using calipers.																														
4	Dielectric Strength	No defects or abnormalities.	No failure shall be observed when 150% of the rated voltage (200% of the rated voltage in case of rated voltage: DC 250V) is applied between the terminations for 1 to 5 s, provided the charge/discharge current is less than 50mA.																														
5	Insulation Resistance (I.R.)	$C \geq 0.01 \mu\text{F}$ : More than $100\text{M}\Omega \cdot \mu\text{F}$ $C < 0.01 \mu\text{F}$ : More than $10,000\text{M}\Omega$	The insulation resistance shall be measured with $500 \pm 50\text{V}$ ( $250 \pm 50\text{V}$ in case of rated voltage: DC 250V) and within $60 \pm 5$ s of charging.																														
6	Capacitance	Within the specified tolerance.	The capacitance/D.F. shall be measured at 20°C at a frequency of $1 \pm 0.2\text{kHz}$ and a voltage of $1 \pm 0.2\text{V}$ (r.m.s.)																														
7	Dissipation Factor (D.F.)	0.025 max.																															
8	Capacitance Temperature Characteristics	Cap. Change Within $\pm 10\%$ (Temp. Range : -25 to +85°C)	The range of capacitance change compared with the 20°C value within -25 to +85°C shall be within the specified range. •Pretreatment Perform a heat treatment at $150 \pm 0.5^\circ\text{C}$ for $60 \pm 5$ min and then let sit for $24 \pm 2$ h at room condition.																														
9	Adhesive Strength of Termination	No removal of the terminations or other defect shall occur.	Solder the capacitor to the testing jig (glass epoxy board) shown in Fig.1 using a eutectic solder. Then apply 10N force in the direction of the arrow. The soldering shall be done either with an iron or using the reflow method and shall be conducted with care so that the soldering is uniform and free of defects such as heat shock.  10N, 10±1s Speed : 1.0mm/s Glass Epoxy Board Fig.1																														
10	Vibration Resistance	Appearance	No defects or abnormalities.																														
		Capacitance	Within the specified tolerance.																														
		D.F.	0.025 max.																														
			Solder the capacitor to the test jig (glass epoxy board). The capacitor shall be subjected to a simple harmonic motion having a total amplitude of 1.5mm, the frequency being varied uniformly between the approximate limits of 10 and 55Hz. The frequency range, from 10 to 55Hz and return to 10Hz, shall be traversed in approximately 1 min. This motion shall be applied for a period of 2 h in each 3 mutually perpendicular directions (total of 6 h).  Solder resist Cu Glass Epoxy Board																														
11	Deflection	No cracking or marking defects shall occur.	Solder the capacitor to the testing jig (glass epoxy board) shown in Fig.2 using a eutectic solder. Then apply a force in the direction shown in Fig.3. The soldering shall be done either with an iron or using the reflow method and shall be conducted with care so that the soldering is uniform and free of defects such as heat shock.  Fig.2 <table border="1" data-bbox="375 1792 885 1971"> <thead> <tr> <th rowspan="2">L×W (mm)</th> <th colspan="4">Dimension (mm)</th> </tr> <tr> <th>a</th> <th>b</th> <th>c</th> <th>d</th> </tr> </thead> <tbody> <tr> <td>2.0×1.25</td> <td>1.2</td> <td>4.0</td> <td>1.65</td> <td rowspan="5">1.0</td> </tr> <tr> <td>3.2×1.6</td> <td>2.2</td> <td>5.0</td> <td>2.0</td> </tr> <tr> <td>3.2×2.5</td> <td>2.2</td> <td>5.0</td> <td>2.9</td> </tr> <tr> <td>4.5×3.2</td> <td>3.5</td> <td>7.0</td> <td>3.7</td> </tr> <tr> <td>5.7×5.0</td> <td>4.5</td> <td>8.0</td> <td>5.6</td> </tr> </tbody> </table> Fig.3  20 50 Pressurizing speed : 1.0mm/s Pressurize R230 Flexure=1 Capacitance meter 45 45 (in mm) Fig.3	L×W (mm)	Dimension (mm)				a	b	c	d	2.0×1.25	1.2	4.0	1.65	1.0	3.2×1.6	2.2	5.0	2.0	3.2×2.5	2.2	5.0	2.9	4.5×3.2	3.5	7.0	3.7	5.7×5.0	4.5	8.0	5.6
		L×W (mm)			Dimension (mm)																												
a	b		c	d																													
2.0×1.25	1.2	4.0	1.65	1.0																													
3.2×1.6	2.2	5.0	2.0																														
3.2×2.5	2.2	5.0	2.9																														
4.5×3.2	3.5	7.0	3.7																														
5.7×5.0	4.5	8.0	5.6																														

"Room condition" Temperature : 15 to 35°C, Relative humidity : 45 to 75%, Atmosphere pressure : 86 to 106kPa

Continued on the following page 

## Specifications and Test Methods

 Continued from the preceding page.

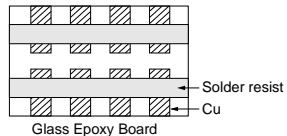
No.	Item	Specification	Test Method															
12	Solderability of Termination	75% of the terminations is to be soldered evenly and continuously.	Immerse the capacitor in a solution of ethanol (JIS-K-8101) and rosin (JIS-K-5902) (25% rosin in weight proportion). Immerse in eutectic solder solution for $2\pm 0.5$ s at $235\pm 5^\circ\text{C}$ . Immersing speed : $25\pm 2.5\text{mm/s}$															
13	Resistance to Soldering Heat	Appearance	No marking defects.															
		Capacitance Change	Within $\pm 10\%$															
		D.F.	0.025 max.															
		I.R.	$C\geq 0.01\mu\text{F}$ : More than $100\text{M}\Omega \cdot \mu\text{F}$ $C < 0.01\mu\text{F}$ : More than $10,000\text{M}\Omega$															
		Dielectric Strength	Pass the item No.4.															
			Preheat the capacitor at $120$ to $150^\circ\text{C}$ * for 1 min. Immerse the capacitor in eutectic solder solution at $260\pm 5^\circ\text{C}$ for $10\pm 1$ s. Let sit at room condition for $24\pm 2$ h, then measure. •Immersing speed : $25\pm 2.5\text{mm/s}$ •Pretreatment Perform a heat treatment at $150\pm 1.8^\circ\text{C}$ for $60\pm 5$ min and then let sit for $24\pm 2$ h at room condition.  *Preheating for more than $3.2\times 2.5\text{mm}$															
			<table border="1"> <thead> <tr> <th>Step</th> <th>Temperature</th> <th>Time</th> </tr> </thead> <tbody> <tr> <td>1</td> <td><math>100^\circ\text{C}</math> to <math>120^\circ\text{C}</math></td> <td>1 min.</td> </tr> <tr> <td>2</td> <td><math>170^\circ\text{C}</math> to <math>200^\circ\text{C}</math></td> <td>1 min.</td> </tr> </tbody> </table>	Step	Temperature	Time	1	$100^\circ\text{C}$ to $120^\circ\text{C}$	1 min.	2	$170^\circ\text{C}$ to $200^\circ\text{C}$	1 min.						
Step	Temperature	Time																
1	$100^\circ\text{C}$ to $120^\circ\text{C}$	1 min.																
2	$170^\circ\text{C}$ to $200^\circ\text{C}$	1 min.																
14	Temperature Cycle	Appearance	No marking defects.															
		Capacitance Change	Within $\pm 7.5\%$															
		D.F.	0.025 max.															
		I.R.	$C\geq 0.01\mu\text{F}$ : More than $100\text{M}\Omega \cdot \mu\text{F}$ $C < 0.01\mu\text{F}$ : More than $10,000\text{M}\Omega$															
		Dielectric Strength	Pass the item No.4.															
			Fix the capacitor to the supporting jig (glass epoxy board) shown in Fig.4 using a eutectic solder. Perform the five cycles according to the four heat treatments listed in the following table. Let sit for $24\pm 2$ h at room condition, then measure.															
			<table border="1"> <thead> <tr> <th>Step</th> <th>Temperature (<math>^\circ\text{C}</math>)</th> <th>Time (min)</th> </tr> </thead> <tbody> <tr> <td>1</td> <td>Min. Operating Temp.<math>\pm 3</math></td> <td><math>30\pm 3</math></td> </tr> <tr> <td>2</td> <td>Room Temp.</td> <td>2 to 3</td> </tr> <tr> <td>3</td> <td>Max. Operating Temp.<math>\pm 2</math></td> <td><math>30\pm 3</math></td> </tr> <tr> <td>4</td> <td>Room Temp.</td> <td>2 to 3</td> </tr> </tbody> </table>	Step	Temperature ( $^\circ\text{C}$ )	Time (min)	1	Min. Operating Temp. $\pm 3$	$30\pm 3$	2	Room Temp.	2 to 3	3	Max. Operating Temp. $\pm 2$	$30\pm 3$	4	Room Temp.	2 to 3
Step	Temperature ( $^\circ\text{C}$ )	Time (min)																
1	Min. Operating Temp. $\pm 3$	$30\pm 3$																
2	Room Temp.	2 to 3																
3	Max. Operating Temp. $\pm 2$	$30\pm 3$																
4	Room Temp.	2 to 3																
			•Pretreatment Perform a heat treatment at $150\pm 1.8^\circ\text{C}$ for $60\pm 5$ min and then let sit for $24\pm 2$ h at room condition.															
			 <p style="text-align: center;">Fig.4</p>															
15	Humidity (Steady State)	Appearance	No marking defects.															
		Capacitance Change	Within $\pm 15\%$															
		D.F.	0.05 max.															
		I.R.	$C\geq 0.01\mu\text{F}$ : More than $10\text{M}\Omega \cdot \mu\text{F}$ $C < 0.01\mu\text{F}$ : More than $1,000\text{M}\Omega$															
		Dielectric Strength	Pass the item No.4.															
			Sit the capacitor at $40\pm 2^\circ\text{C}$ and relative humidity 90 to 95% for $500\pm 2.3$ h. Remove and let sit for $24\pm 2$ h at room condition, then measure. •Pretreatment Perform a heat treatment at $150\pm 1.8^\circ\text{C}$ for $60\pm 5$ min and then let sit for $24\pm 2$ h at room condition.															
16	Life	Appearance	No marking defects.															
		Capacitance Change	Within $\pm 15\%$															
		D.F.	0.05 max.															
		I.R.	$C\geq 0.01\mu\text{F}$ : More than $10\text{M}\Omega \cdot \mu\text{F}$ $C < 0.01\mu\text{F}$ : More than $1,000\text{M}\Omega$															
		Dielectric Strength	Pass the item No.4.															
			Apply 120% of the rated voltage (150% of the rated voltage in case of rated voltage: DC250V) for $1,000\pm 4.8$ h at maximum operating temperature $\pm 3^\circ\text{C}$ . Remove and let sit for $24\pm 2$ h at room condition, then measure. The charge/discharge current is less than 50mA. •Pretreatment Apply test voltage for $60\pm 5$ min at test temperature. Remove and let sit for $24\pm 2$ h at room condition.															
17	Humidity Loading	Appearance	No marking defects.															
		Capacitance Change	Within $\pm 15\%$															
		D.F.	0.05 max.															
		I.R.	$C\geq 0.01\mu\text{F}$ : More than $10\text{M}\Omega \cdot \mu\text{F}$ $C < 0.01\mu\text{F}$ : More than $1,000\text{M}\Omega$															
		Dielectric Strength	Pass the item No.4.															
			Apply the rated voltage at $40\pm 2^\circ\text{C}$ and relative humidity 90 to 95% for $500\pm 2.3$ h. Remove and let sit for $24\pm 2$ h at room condition, then measure. •Pretreatment Apply test voltage for $60\pm 5$ min at test temperature. Remove and let sit for $24\pm 2$ h at room condition.															

"Room condition" Temperature : 15 to  $35^\circ\text{C}$ , Relative humidity : 45 to 75%, Atmosphere pressure : 86 to  $106\text{kPa}$

# CHIP MONOLITHIC CERAMIC CAPACITOR

## for High-voltage GHM2000 Series AC250V r.m.s.

### ■ Features

1. Chip monolithic ceramic capacitor for AC line.
2. A new monolithic structure for small, high-capacitance capable of operating at high-voltage levels.
3. Sn-plated external electrodes allow mounting without silver compound solder.
4. Only for Reflow soldering.
5. Capacitance 0.01 to 0.1 uF for connecting lines and 470 to 4700 pF for connecting line to earth.

### ■ Application

Noise suppression filters for switching power supplies, telephones, facsimiles, modems.

### ■ Reference Standard

JIS C 5102

JIS C 5150

The standards of the electrical appliance and material control law of Japan, separated table 4.

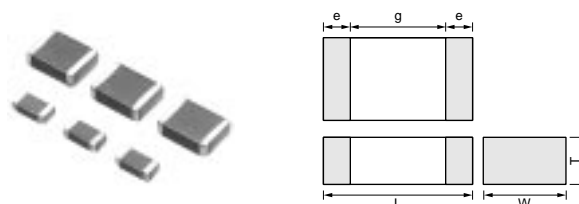

Part Number	Dimensions (mm)				
	L	W	T	e min.	g min.
<b>GHM2143</b>	5.7 ±0.4	2.8 ±0.3	2.0 ±0.3	0.3	3.5
<b>GHM2145</b>		5.0 ±0.4			
<b>GHM2243</b>		2.8 ±0.3			

Part Number	Rated Voltage (V)	TC Code	Capacitance	Length L (mm)	Width W (mm)	Thickness T (mm)	Electrode g (mm)	Electrode e (mm)
<b>GHM2243B471MAC250</b>	AC250 (r.m.s.)	B	470pF +20,-20%	5.7	2.8	2.0	3.5 min.	0.3 min.
<b>GHM2243B102MAC250</b>	AC250 (r.m.s.)	B	1000pF +20,-20%	5.7	2.8	2.0	3.5 min.	0.3 min.
<b>GHM2243B222MAC250</b>	AC250 (r.m.s.)	B	2200pF +20,-20%	5.7	2.8	2.0	3.5 min.	0.3 min.
<b>GHM2243B472MAC250</b>	AC250 (r.m.s.)	B	4700pF +20,-20%	5.7	2.8	2.0	3.5 min.	0.3 min.
<b>GHM2143B103MAC250</b>	AC250 (r.m.s.)	B	10000pF +20,-20%	5.7	2.8	2.0	3.5 min.	0.3 min.
<b>GHM2143B223MAC250</b>	AC250 (r.m.s.)	B	22000pF +20,-20%	5.7	2.8	2.0	3.5 min.	0.3 min.
<b>GHM2143B473MAC250</b>	AC250 (r.m.s.)	B	47000pF +20,-20%	5.7	2.8	2.0	3.5 min.	0.3 min.
<b>GHM2145B104MAC250</b>	AC250 (r.m.s.)	B	0.1μF +20,-20%	5.7	5.0	2.0	3.5 min.	0.3 min.

## Specifications and Test Methods

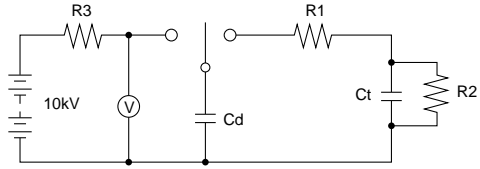
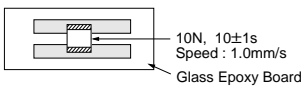
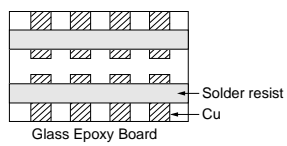
No.	Item	Specification	Test Method						
1	Operating Temperature Range	-25 to +85°C	-						
2	Appearance	No defects or abnormalities.	Visual inspection.						
3	Dimensions	Within the specified dimensions.	Using calipers.						
4	Dielectric Strength	No defects or abnormalities.	No failure shall be observed when voltage as table is applied between the terminations for 60±1 s, provided the charge/discharge current is less than 50mA. <table border="1"> <thead> <tr> <th></th> <th>Test voltage</th> </tr> </thead> <tbody> <tr> <td>GHM21xx</td> <td>AC575V (r.m.s.)</td> </tr> <tr> <td>GHM22xx</td> <td>AC1500V (r.m.s.)</td> </tr> </tbody> </table>		Test voltage	GHM21xx	AC575V (r.m.s.)	GHM22xx	AC1500V (r.m.s.)
	Test voltage								
GHM21xx	AC575V (r.m.s.)								
GHM22xx	AC1500V (r.m.s.)								
5	Insulation Resistance (I.R.)	More than 2,000MΩ	The insulation resistance shall be measured with 500±50V and within 60±5 s of charging.						
6	Capacitance	Within the specified tolerance.	The capacitance/D.F. shall be measured at 20°C at a frequency of 1±0.2kHz and a voltage of 1±0.2V (r.m.s.)						
7	Dissipation Factor (D.F.)	0.025 max.							
8	Capacitance Temperature Characteristics	Cap. Change Within ±10%	The range of capacitance change compared with the 20°C value within -25 to +85°C shall be within the specified range. •Pretreatment Perform a heat treatment at 150±18°C for 60±5 min and then let sit for 24±2 h at room condition.						
9	Discharge Test (Application: GHM22xx)	Appearance	No defects or abnormalities. As in Fig., discharge is made 50 times at 5 s intervals from the capacitor(Cd) charged at DC voltage of specified.  Ct : Capacitor under test Cd : 0.001μF R1 : 1,000Ω R2 : 100MΩ R3 : Surge resistance						
10	Adhesive Strength of Termination	No removal of the terminations or other defect shall occur.	Solder the capacitor to the testing jig (glass epoxy board) shown in Fig.1 using a eutectic solder. Then apply 10N force in the direction of the arrow. The soldering shall be done either with an iron or using the reflow method and shall be conducted with care so that the soldering is uniform and free of defects such as heat shock.  Fig.1						
11	Vibration Resistance	Appearance	No defects or abnormalities.						
		Capacitance	Within the specified tolerance.						
	D.F.	0.025 max.	Solder the capacitor to the test jig (glass epoxy board). The capacitor shall be subjected to a simple harmonic motion having a total amplitude of 1.5mm, the frequency being varied uniformly between the approximate limits of 10 and 55Hz. The frequency range, from 10 to 55Hz and return to 10Hz, shall be traversed in approximately 1 min. This motion shall be applied for a period of 2 h in each 3 mutually perpendicular directions (total of 6 h). 						

"Room condition" Temperature : 15 to 35°C, Relative humidity : 45 to 75%, Atmosphere pressure : 86 to 106kPa

Continued on the following page. 

## Specifications and Test Methods

Continued from the preceding page.

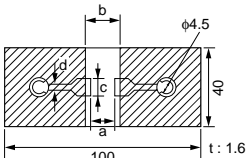
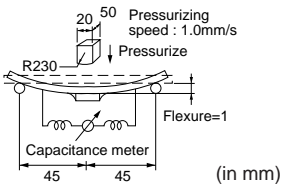
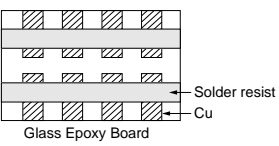
No.	Item	Specification	Test Method																		
12	Deflection	No cracking or marking defects shall occur.	<p>Solder the capacitor to the testing jig (glass epoxy board) shown in Fig.2 using a eutectic solder. Then apply a force in the direction shown in Fig. 3. The soldering shall be done either with an iron or using the reflow method and shall be conducted with care so that the soldering is uniform and free of defects such as heat shock.</p>  <table border="1" data-bbox="375 548 885 649"> <thead> <tr> <th rowspan="2">L×W (mm)</th> <th colspan="4">Dimension (mm)</th> </tr> <tr> <th>a</th> <th>b</th> <th>c</th> <th>d</th> </tr> </thead> <tbody> <tr> <td>5.7×2.8</td> <td>4.5</td> <td>8.0</td> <td>3.2</td> <td rowspan="2">1.0</td> </tr> <tr> <td>5.7×5.0</td> <td>4.5</td> <td>8.0</td> <td>5.6</td> </tr> </tbody> </table> <p style="text-align: center;">Fig.2</p>  <p style="text-align: center;">Fig.3</p>	L×W (mm)	Dimension (mm)				a	b	c	d	5.7×2.8	4.5	8.0	3.2	1.0	5.7×5.0	4.5	8.0	5.6
		L×W (mm)			Dimension (mm)																
a	b		c	d																	
5.7×2.8	4.5	8.0	3.2	1.0																	
5.7×5.0	4.5	8.0	5.6																		
13	Solderability of Termination	75% of the terminations is to be soldered evenly and continuously.	<p>Immerse the capacitor in a solution of ethanol (JIS-K-8101) and rosin (JIS-K-5902) (25% rosin in weight proportion). Immerse in eutectic solder solution for <math>2\pm 0.5</math> s at <math>235\pm 5^\circ\text{C}</math>. Immersing speed : <math>25\pm 2.5</math>mm/s</p>																		
14	Humidity Insulation	Appearance	No marking defects.	<p>The capacitor shall be subjected to <math>40\pm 2^\circ\text{C}</math>, relative humidity of 90 to 98% for 8 h, and then removed in room condition for 16 h until 5 cycles.</p>																	
		Capacitance Change	Within $\pm 15\%$																		
		D.F.	0.05 max.																		
		I.R.	More than 1,000M $\Omega$																		
		Dielectric Strength	Pass the item No.4.																		
15	Resistance to Soldering Heat	Appearance	No marking defects.	<p>Preheat the capacitor as table. Immerse the capacitor in eutectic solder solution at <math>260\pm 5^\circ\text{C}</math> for <math>10\pm 1</math> s. Let sit at room condition for <math>24\pm 2</math> h, then measure. •Immersing speed : <math>25\pm 2.5</math>mm/s •Pretreatment Perform a heat treatment at <math>150\pm 1.8^\circ\text{C}</math> for <math>60\pm 5</math> min and then let sit for <math>24\pm 2</math> h at room condition.</p> <p>*Preheating</p> <table border="1" data-bbox="941 1243 1452 1332"> <thead> <tr> <th>Step</th> <th>Temperature</th> <th>Time</th> </tr> </thead> <tbody> <tr> <td>1</td> <td>100°C to 120°C</td> <td>1 min.</td> </tr> <tr> <td>2</td> <td>170°C to 200°C</td> <td>1 min.</td> </tr> </tbody> </table>	Step	Temperature	Time	1	100°C to 120°C	1 min.	2	170°C to 200°C	1 min.								
		Step	Temperature		Time																
		1	100°C to 120°C		1 min.																
		2	170°C to 200°C		1 min.																
		Capacitance Change	Within $\pm 10\%$																		
D.F.	0.025 max.																				
I.R.	More than 2,000M $\Omega$																				
Dielectric Strength	Pass the item No.4.																				
16	Temperature Cycle	Appearance	No marking defects.	<p>Fix the capacitor to the supporting jig (glass epoxy board) shown in Fig.4 using a eutectic solder. Perform the five cycles according to the four heat treatments listed in the following table. Let sit for <math>24\pm 2</math> h at room condition, then measure.</p> <table border="1" data-bbox="941 1467 1452 1590"> <thead> <tr> <th>Step</th> <th>Temperature (°C)</th> <th>Time (min)</th> </tr> </thead> <tbody> <tr> <td>1</td> <td>Min. Operating Temp.±3</td> <td>30±3</td> </tr> <tr> <td>2</td> <td>Room Temp.</td> <td>2 to 3</td> </tr> <tr> <td>3</td> <td>Max. Operating Temp.±2</td> <td>30±3</td> </tr> <tr> <td>4</td> <td>Room Temp.</td> <td>2 to 3</td> </tr> </tbody> </table> <p>•Pretreatment Perform a heat treatment at <math>150\pm 1.8^\circ\text{C}</math> for <math>60\pm 5</math> min and then let sit for <math>24\pm 2</math> h at room condition.</p>  <p style="text-align: center;">Fig.4</p>	Step	Temperature (°C)	Time (min)	1	Min. Operating Temp.±3	30±3	2	Room Temp.	2 to 3	3	Max. Operating Temp.±2	30±3	4	Room Temp.	2 to 3		
		Step	Temperature (°C)		Time (min)																
		1	Min. Operating Temp.±3		30±3																
		2	Room Temp.		2 to 3																
		3	Max. Operating Temp.±2		30±3																
4	Room Temp.	2 to 3																			
Capacitance Change	Within $\pm 7.5\%$																				
D.F.	0.025 max.																				
I.R.	More than 2,000M $\Omega$																				
Dielectric Strength	Pass the item No.4.																				

"Room condition" Temperature : 15 to 35°C, Relative humidity : 45 to 75%, Atmosphere pressure : 86 to 106kPa

Continued on the following page. 

## Specifications and Test Methods

 Continued from the preceding page.

No.	Item	Specification	Test Method
17	Humidity (Steady State)	Appearance	No marking defects.
		Capacitance Change	Within $\pm 15\%$
		D.F.	0.05 max.
		I.R.	More than 1,000M $\Omega$
		Dielectric Strength	Pass the item No.4.
18	Life	Appearance	No marking defects.
		Capacitance Change	Within $\pm 15\%$
		D.F.	0.05 max.
		I.R.	More than 1,000M $\Omega$
		Dielectric Strength	Pass the item No.4.
19	Humidity Loading	Appearance	No marking defects.
		Capacitance Change	Within $\pm 15\%$
		D.F.	0.05 max.
		I.R.	More than 1,000M $\Omega$
		Dielectric Strength	Pass the item No.4.

Sit the capacitor at  $40\pm 2^\circ\text{C}$  and relative humidity 90 to 95% for  $500\pm 2\frac{3}{8}$  h.  
Remove and let sit for  $24\pm 2$  h at room condition, then measure.  
•Pretreatment  
Perform a heat treatment at  $150\pm 1.8^\circ\text{C}$  for  $60\pm 5$  min and then let sit for  $24\pm 2$  h at room condition.

Apply voltage and time as Table at  $85\pm 2^\circ\text{C}$ . Remove and let sit for  $24\pm 2$  h at room condition, then measure. The charge / discharge current is less than 50mA.

	Test Time	Test voltage
GHM21xx	$1,000\pm 4\frac{8}{8}$ h	AC300V (r.m.s.)
GHM22xx	$1,500\pm 4\frac{8}{8}$ h	AC500V (r.m.s.) *

\* Except that once each hour the voltage is increased to AC1,000V (r.m.s.) for 0.1 s

•Pretreatment  
Apply test voltage for  $60\pm 5$  min at test temperature.  
Remove and let sit for  $24\pm 2$  h at room condition.

Apply the rated voltage at  $40\pm 2^\circ\text{C}$  and relative humidity 90 to 95% for  $500\pm 2\frac{3}{8}$  h.  
Remove and let sit for  $24\pm 2$  h at room condition, then measure.  
•Pretreatment  
Apply test voltage for  $60\pm 5$  min at test temperature.  
Remove and let sit for  $24\pm 2$  h at room condition.

"Room condition" Temperature : 15 to  $35^\circ\text{C}$ , Relative humidity : 45 to 75%, Atmosphere pressure : 86 to 106kPa

DataSheet4U.com

et4U.com

DataShee

# CHIP MONOLITHIC CERAMIC CAPACITOR

## for High-voltage GHM3000 Series Safety Recognized

### ■ Features

1. Chip monolithic ceramic capacitor (certified as conforming to safety standards) for AC line.
2. A new monolithic structure for small, high-capacitance capable of operating at high-voltage levels.
3. Compared to lead type capacitors, this new capacitor is greatly downsized and low-profiled to 1/10 or less in volume, and 1/4 or less in height.
4. The type GB can be used as an X2-class capacitor.
5. The type GC can be used as an X1-class and Y2-class capacitor.
6. +125 degree C guaranteed.
7. Only for reflow soldering.

### ■ Application

1. Ideal use as Y capacitor or X capacitor for various switching power supply.
2. Ideal use as linefilter for MODEM.

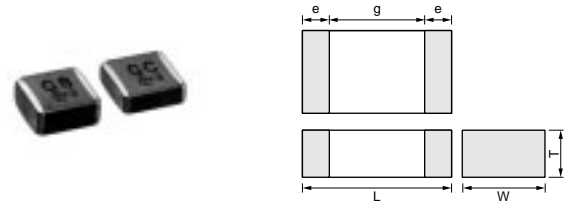

Part Number	Dimensions (mm)				
	L	W	T	e min.	g min.
<b>GHM3045</b>	5.7 ±0.4	5.0 ±0.4	2.0 ±0.3	0.3	4.0
<b>GHM3145</b>			2.0 ±0.3		
			2.7 ±0.3		

### ■ Standard Recognition

	Standard No.	Status of Recognition		Rated Voltage
		Type GB	Type GC	
UL	UL1414	—	◎*	AC250V (r.m.s.)
BSI	EN132400	—	◎	
VDE		◎	◎	
SEV		◎	◎	
SEMKO		◎	◎	
EN132400 Class		X2	X1, Y2	

\* : Line By Pass only

### GC Type

Part Number	Rated Voltage (V)	TC Code	Capacitance (pF)	Length L (mm)	Width W (mm)	Thickness T (mm)	Electrode g (mm)	Electrode e (mm)
<b>GHM3045X7R101K-GC</b>	AC250 (r.m.s.)	X7R	100 +10,-10%	5.7	5.0	2.0	4.0 min.	0.3 min.
<b>GHM3045X7R151K-GC</b>	AC250 (r.m.s.)	X7R	150 +10,-10%	5.7	5.0	2.0	4.0 min.	0.3 min.
<b>GHM3045X7R221K-GC</b>	AC250 (r.m.s.)	X7R	220 +10,-10%	5.7	5.0	2.0	4.0 min.	0.3 min.
<b>GHM3045X7R331K-GC</b>	AC250 (r.m.s.)	X7R	330 +10,-10%	5.7	5.0	2.0	4.0 min.	0.3 min.
<b>GHM3045X7R471K-GC</b>	AC250 (r.m.s.)	X7R	470 +10,-10%	5.7	5.0	2.0	4.0 min.	0.3 min.
<b>GHM3045X7R681K-GC</b>	AC250 (r.m.s.)	X7R	680 +10,-10%	5.7	5.0	2.0	4.0 min.	0.3 min.
<b>GHM3045X7R102K-GC</b>	AC250 (r.m.s.)	X7R	1000 +10,-10%	5.7	5.0	2.0	4.0 min.	0.3 min.
<b>GHM3045X7R152K-GC</b>	AC250 (r.m.s.)	X7R	1500 +10,-10%	5.7	5.0	2.0	4.0 min.	0.3 min.
<b>GHM3045X7R222K-GC</b>	AC250 (r.m.s.)	X7R	2200 +10,-10%	5.7	5.0	2.0	4.0 min.	0.3 min.
<b>GHM3045X7R332K-GC</b>	AC250 (r.m.s.)	X7R	3300 +10,-10%	5.7	5.0	2.0	4.0 min.	0.3 min.
<b>GHM3045X7R472K-GC</b>	AC250 (r.m.s.)	X7R	4700 +10,-10%	5.7	5.0	2.0	4.0 min.	0.3 min.

### GB Type

Part Number	Rated Voltage (V)	TC Code	Capacitance (pF)	Length L (mm)	Width W (mm)	Thickness T (mm)	Electrode g (mm)	Electrode e (mm)
<b>GHM3145X7R103K-GB</b>	AC250 (r.m.s.)	X7R	10000 +10,-10%	5.7	5.0	2.0	4.0 min.	0.3 min.
<b>GHM3145X7R153K-GB</b>	AC250 (r.m.s.)	X7R	15000 +10,-10%	5.7	5.0	2.0	4.0 min.	0.3 min.
<b>GHM3145X7R223K-GB</b>	AC250 (r.m.s.)	X7R	22000 +10,-10%	5.7	5.0	2.0	4.0 min.	0.3 min.
<b>GHM3145X7R333K-GB</b>	AC250 (r.m.s.)	X7R	33000 +10,-10%	5.7	5.0	2.7	4.0 min.	0.3 min.

Dielectric Strength: DC1075V, 60+/- 1s.

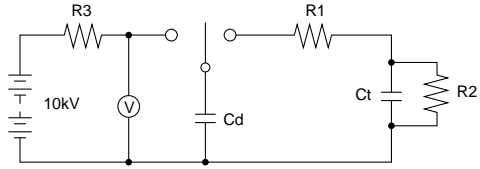
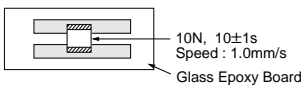
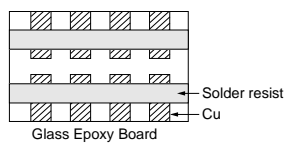

## Specifications and Test Methods

No.	Item	Specification	Test Method						
1	Operating Temperature Range	-55 to +125°C	-						
2	Appearance	No defects or abnormalities.	Visual inspection.						
3	Dimensions	Within the specified dimensions.	Using calipers.						
4	Dielectric Strength	No defects or abnormalities.	No failure shall be observed when voltage as table is applied between the terminations for 60±1 s, provided the charge/discharge current is less than 50mA. <table border="1" style="margin-left: auto; margin-right: auto;"> <thead> <tr> <th></th> <th>Test voltage</th> </tr> </thead> <tbody> <tr> <td>Type GB</td> <td>DC1075V</td> </tr> <tr> <td>Type GC</td> <td>AC1500V (r.m.s.)</td> </tr> </tbody> </table>		Test voltage	Type GB	DC1075V	Type GC	AC1500V (r.m.s.)
	Test voltage								
Type GB	DC1075V								
Type GC	AC1500V (r.m.s.)								
5	Insulation Resistance (I.R.)	More than 6,000MΩ	The insulation resistance shall be measured with 500±50V and within 60±5 s of charging.						
6	Capacitance	Within the specified tolerance.	The capacitance/D.F. shall be measured at 20°C at a frequency of 1±0.2kHz and a voltage of 1±0.2V (r.m.s.)						
7	Dissipation Factor (D.F.)	0.025 max.							
8	Capacitance Temperature Characteristics	Cap. Change Within ±15%	The range of capacitance change compared with the 25°C value within -55 to +125°C shall be within the specified range. •Pretreatment Perform a heat treatment at 150 ± 1°C for 60±5 min and then let sit for 24±2 h at room condition.						
9	Discharge Test (Application: Type GC)	Appearance	No defects or abnormalities.						
		I.R.	More than 1,000MΩ						
	Dielectric Strength	Pass the item No.4.	As in Fig., discharge is made 50 times at 5 s intervals from the capacitor(Cd) charged at DC voltage of specified.  Ct : Capacitor under test Cd : 0.001μF R1 : 1,000Ω R2 : 100MΩ R3 : Surge resistance						
10	Adhesive Strength of Termination	No removal of the terminations or other defect shall occur.	Solder the capacitor to the testing jig (glass epoxy board) shown in Fig.1 using a eutectic solder. Then apply 10N force in the direction of the arrow. The soldering shall be done either with an iron or using the reflow method and shall be conducted with care so that the soldering is uniform and free of defects such as heat shock.  Fig.1						
11	Vibration Resistance	Appearance	No defects or abnormalities.						
		Capacitance	Within the specified tolerance.						
	D.F.	0.025 max.	Solder the capacitor to the test jig (glass epoxy board). The capacitor shall be subjected to a simple harmonic motion having a total amplitude of 1.5mm, the frequency being varied uniformly between the approximate limits of 10 and 55Hz. The frequency range, from 10 to 55Hz and return to 10Hz, shall be traversed in approximately 1 min. This motion shall be applied for a period of 2 h in each 3 mutually perpendicular directions (total of 6 h). 						

"Room condition" Temperature : 15 to 35°C, Relative humidity : 45 to 75%, Atmosphere pressure : 86 to 106kPa

Continued on the following page.

## Specifications and Test Methods

Continued from the preceding page.

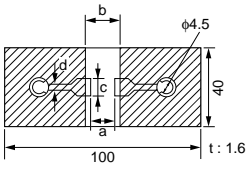
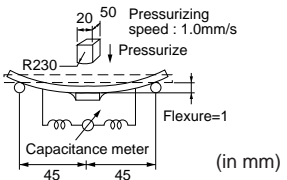
No.	Item	Specification	Test Method														
12	Deflection	No cracking or marking defects shall occur.	<p>Solder the capacitor to the testing jig (glass epoxy board) shown in Fig.2 using a eutectic solder. Then apply a force in the direction shown in Fig. 3. The soldering shall be done either with an iron or using the reflow method and shall be conducted with care so that the soldering is uniform and free of defects such as heat shock.</p>  <table border="1" data-bbox="375 548 885 627"> <thead> <tr> <th rowspan="2">LxW (mm)</th> <th colspan="4">Dimension (mm)</th> </tr> <tr> <th>a</th> <th>b</th> <th>c</th> <th>d</th> </tr> </thead> <tbody> <tr> <td>5.7x5.0</td> <td>4.5</td> <td>8.0</td> <td>5.6</td> <td>1.0</td> </tr> </tbody> </table> <p>Fig.2</p>  <p>Fig.3</p>	LxW (mm)	Dimension (mm)				a	b	c	d	5.7x5.0	4.5	8.0	5.6	1.0
		LxW (mm)			Dimension (mm)												
a	b		c	d													
5.7x5.0	4.5	8.0	5.6	1.0													
13	Solderability of Termination	75% of the terminations is to be soldered evenly and continuously.	<p>Immerse the capacitor in a solution of ethanol (JIS-K-8101) and rosin (JIS-K-5902) (25% rosin in weight proportion). Immerse in eutectic solder solution for <math>2\pm 0.5</math> s at <math>235\pm 5^\circ\text{C}</math>. Immersing speed : <math>25\pm 2.5</math>mm/s</p>														
14	Resistance to Soldering Heat	Appearance	No marking defects.														
		Capacitance Change	Within $\pm 10\%$														
		I.R.	More than 1,000M $\Omega$														
		Dielectric Strength	Pass the item No.4.														
15	Temperature Cycle	Appearance	No marking defects.														
		Capacitance Change	Within $\pm 15\%$														
		D.F.	0.05 max.														
		I.R.	More than 3,000M $\Omega$														
		Dielectric Strength	Pass the item No.4.														
16	Humidity (Steady State)	Appearance	No marking defects.														
		Capacitance Change	Within $\pm 15\%$														
		D.F.	0.05 max.														
		I.R.	More than 3,000M $\Omega$														
		Dielectric Strength	Pass the item No.4.														

Immerse the capacitor in a solution of ethanol (JIS-K-8101) and rosin (JIS-K-5902) (25% rosin in weight proportion). Immerse in eutectic solder solution for  $2\pm 0.5$  s at  $235\pm 5^\circ\text{C}$ . Immersing speed :  $25\pm 2.5$ mm/s

Preheat the capacitor as table. Immerse the capacitor in eutectic solder solution at  $260\pm 5^\circ\text{C}$  for  $10\pm 1$  s. Let sit at room condition for  $24\pm 2$  h, then measure.

- Immersing speed :  $25\pm 2.5$ mm/s
- Pretreatment

Perform a heat treatment at  $150\pm 1.8^\circ\text{C}$  for  $60\pm 5$  min and then let sit for  $24\pm 2$  h at room condition.

## \*Preheating

Step	Temperature	Time
1	$100^\circ\text{C}$ to $120^\circ\text{C}$	1 min.
2	$170^\circ\text{C}$ to $200^\circ\text{C}$	1 min.

Fix the capacitor to the supporting jig (glass epoxy board) shown in Fig.4 using a eutectic solder. Perform the five cycles according to the four heat treatments listed in the following table. Let sit for  $24\pm 2$  h at room condition, then measure.

Step	Temperature ( $^\circ\text{C}$ )	Time (min)
1	Min. Operating Temp. $\pm 3$	$30\pm 3$
2	Room Temp.	2 to 3
3	Max. Operating Temp. $\pm 2$	$30\pm 3$
4	Room Temp.	2 to 3

## •Pretreatment

Perform a heat treatment at  $150\pm 1.8^\circ\text{C}$  for  $60\pm 5$  min and then let sit for  $24\pm 2$  h at room condition.

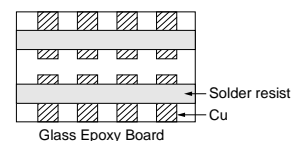



Fig.4

Sit the capacitor at  $40\pm 2^\circ\text{C}$  and relative humidity 90 to 95% for  $500\pm 12$  h. Remove and let sit for  $24\pm 2$  h at room condition, then measure.

"Room condition" Temperature : 15 to  $35^\circ\text{C}$ , Relative humidity : 45 to 75%, Atmosphere pressure : 86 to 106kPa

Continued on the following page. 

## Specifications and Test Methods

 Continued from the preceding page.

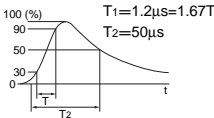
No.	Item	Specification	Test Method						
17	Life	Appearance	Impulse Voltage Each individual capacitor shall be subjected to a 2.5kV (Type GC:5kV) Impulses (the voltage value means zero to peak) for three times. Then the capacitors are applied to life test. 						
		Capacitance Change		Within $\pm 20\%$					
		D.F.		0.05 max.					
		I.R.		More than 3,000M $\Omega$					
		Dielectric Strength		Pass the item No.4.					
18	Humidity Loading	Appearance	Apply voltage as Table for 1,000 h at $125 \pm 2^{\circ}\text{C}$ , relative humidity 50% max. <table border="1" data-bbox="938 488 1449 609"> <thead> <tr> <th>Type</th> <th>Applied voltage</th> </tr> </thead> <tbody> <tr> <td>GB</td> <td>AC312.5V (r.m.s.), except that once each hour the voltage is increased to AC1,000V (r.m.s.) for 0.1s.</td> </tr> <tr> <td>GC</td> <td>AC425V (r.m.s.), except that once each hour the voltage is increased to AC1,000V (r.m.s.) for 0.1s.</td> </tr> </tbody> </table>	Type	Applied voltage	GB	AC312.5V (r.m.s.), except that once each hour the voltage is increased to AC1,000V (r.m.s.) for 0.1s.	GC	AC425V (r.m.s.), except that once each hour the voltage is increased to AC1,000V (r.m.s.) for 0.1s.
		Type		Applied voltage					
		GB		AC312.5V (r.m.s.), except that once each hour the voltage is increased to AC1,000V (r.m.s.) for 0.1s.					
		GC		AC425V (r.m.s.), except that once each hour the voltage is increased to AC1,000V (r.m.s.) for 0.1s.					
		Capacitance Change		Within $\pm 15\%$					
D.F.	0.05 max.								
I.R.	More than 3,000M $\Omega$								
Dielectric Strength	Pass the item No.4.								
18	Humidity Loading	Appearance	Apply the rated voltage at $40 \pm 2^{\circ}\text{C}$ and relative humidity 90 to 95% for $500 \pm 24$ h. Remove and let sit for $24 \pm 2$ h at room condition, then measure.						
		Capacitance Change		Within $\pm 15\%$					
		D.F.		0.05 max.					
		I.R.		More than 3,000M $\Omega$					
		Dielectric Strength		Pass the item No.4.					

"Room condition" Temperature : 15 to 35°C, Relative humidity : 45 to 75%, Atmosphere pressure : 86 to 106kPa

DataSheet4U.com

et4U.com

DataShee

# GHM Series Data

## Capacitance-Temperature Characteristics

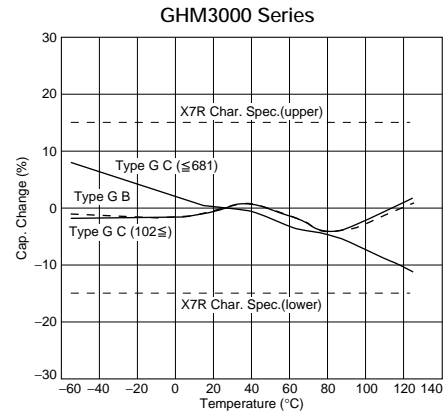
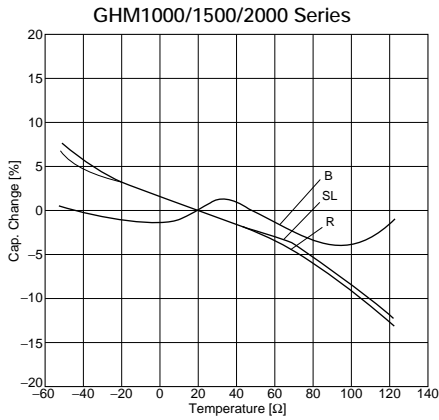

## Impedance-Frequency Characteristics

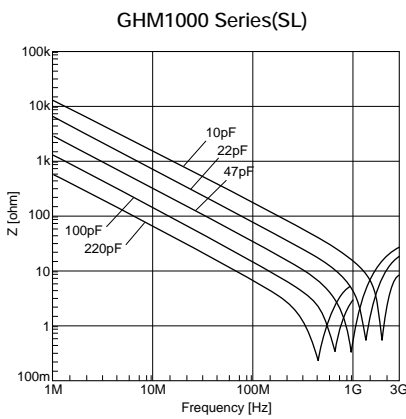

DataSheet4U.com

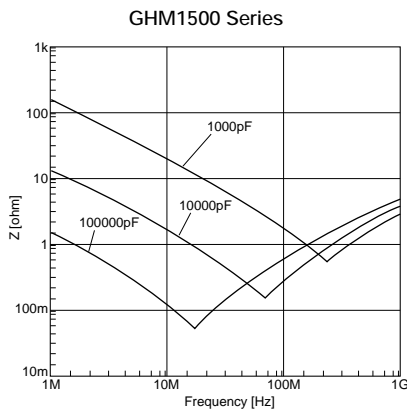
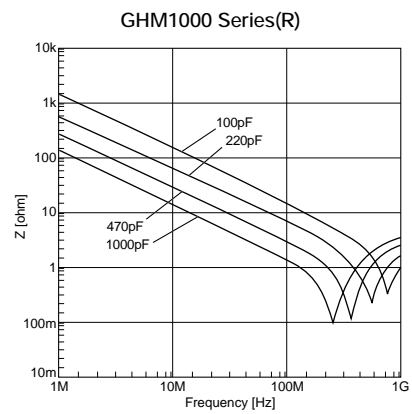

et4U.com

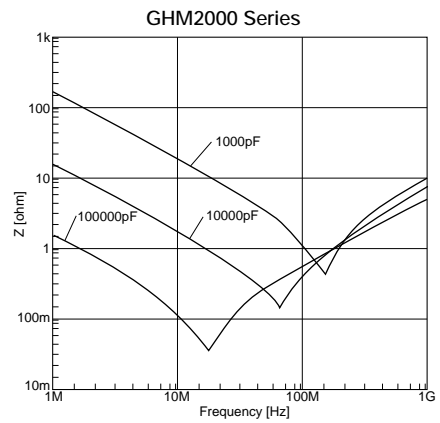

DataShee

Continued on the following page.

# GHM Series Data

Continued from the preceding page.

## Impedance-Frequency Characteristics

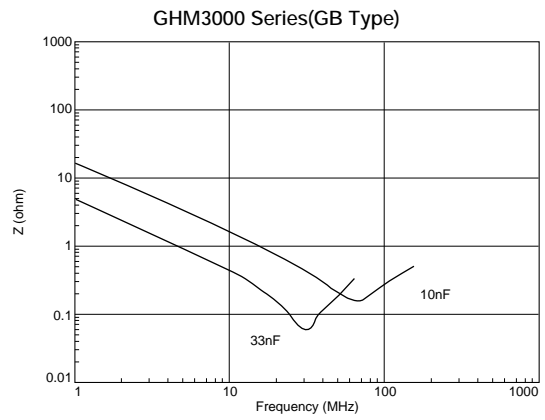
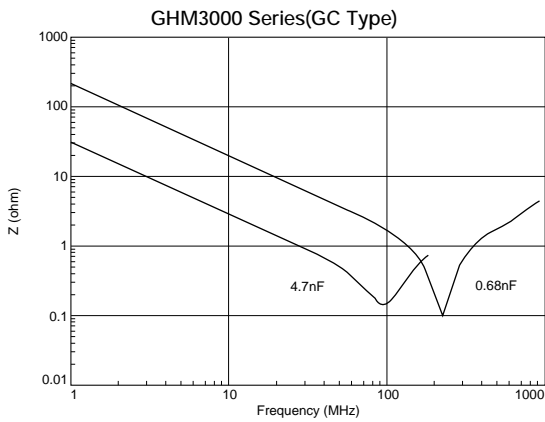

## Capacitance-AC Voltage Characteristics

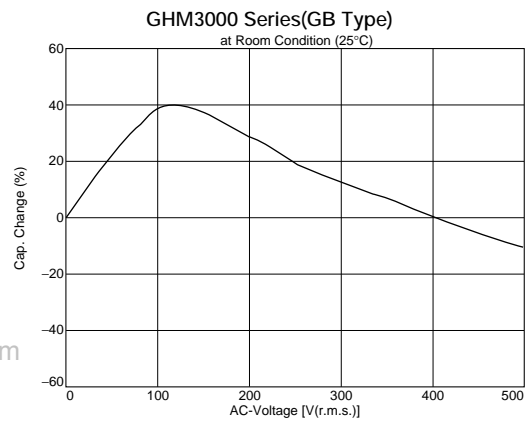
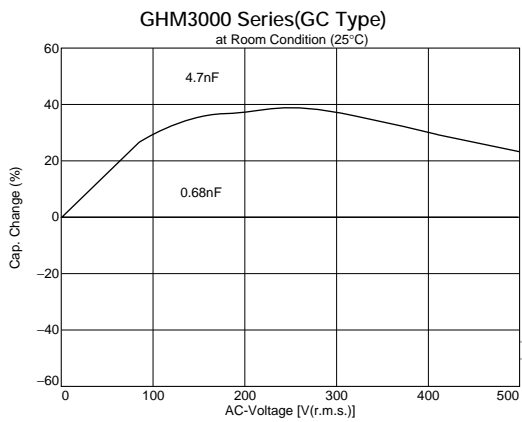

DataSheet4U.com

et4U.com

DataShee

Taping is standard packaging method.

■ Minimum Quantity Guide

Part Number		Dimensions (mm)			Quantity (pcs.)	
					φ180mm reel	
		L	W	T	Paper Tape	Plastic Tape
High-voltage	GHM1030	3.2	1.6	1.0	4,000	-
				1.25	-	3,000
	GHM1035	3.2	2.5	1.5	-	2,000
	GHM1038	4.5	2.0	2.0	-	2,000
	GHM1040	4.5	3.2	2.0	-	1,000
				2.5	-	500
	GHM1525	2.0	1.25	1.0	4,000	-
				1.25	-	3,000
	GHM1530	3.2	1.6	1.0	4,000	-
				1.25	-	3,000
				1.6	-	2,000
	GHM1535	3.2	2.5	1.5	-	2,000
				2.0	-	1,000
	GHM1540	4.5	3.2	1.5	-	1,000
				2.0	-	1,000
2.5				-	500	
2.6				-	500	
GHM1545	5.7	5.0	2.0	-	1,000	
			2.7	-	500	
AC250V	GHM2143	5.7	2.8	2.0	-	1,000
	GHM2145	5.7	5.0	2.0	-	1,000
	GHM2243	5.7	2.8	2.0	-	1,000
Safty Std. Recognition	GHM3045	5.7	5.0	2.0	-	1,000
	GHM3145	5.7	5.0	2.0	-	1,000
				2.7	-	500

■ Tape Carrier Packaging

(1) Appearance of Taping

① Plastic Tape

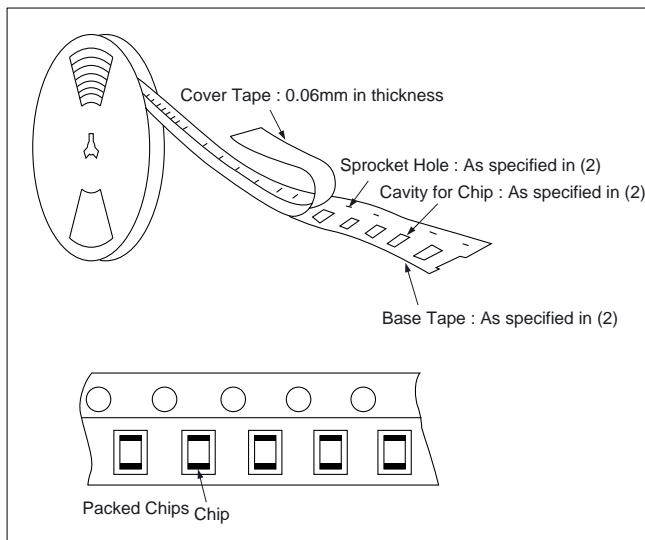

② Paper Tape

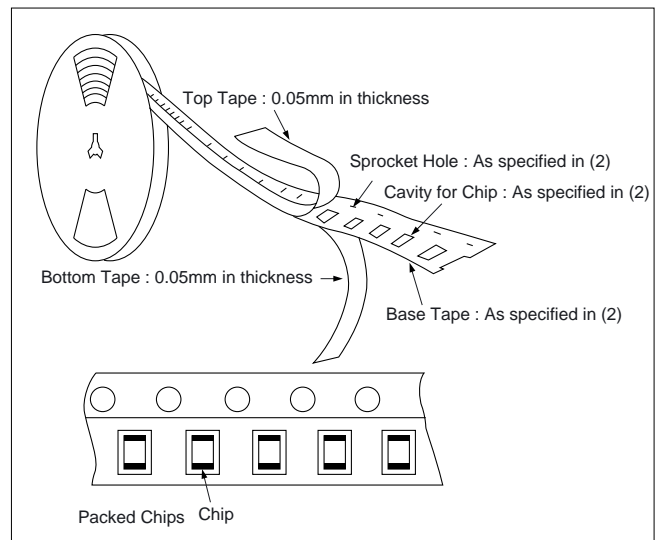

Continued on the following page. ↗

# Package

Continued from the preceding page.

## (2) Dimensions of Tape

### ① Plastic Tape

8mm width 4mm pitch Tape ( $T \geq 1.25$  rank)

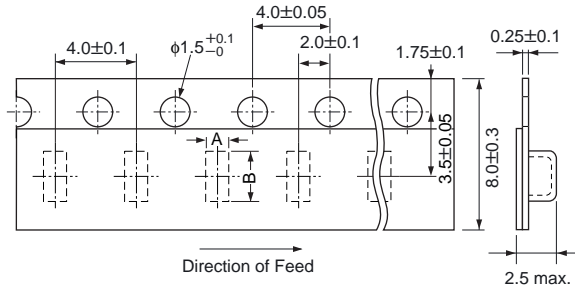

Part Number	A*	B*
<b>GHMxx25</b>	1.45	2.25
<b>GHMxx30</b>	2.0	3.6
<b>GHMxx35</b>	2.9	3.6

\*Nominal Value

12mm width 8mm/4mm pitch Tape

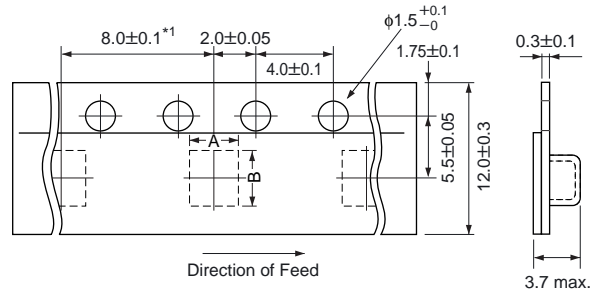

Part Number	A*	B*
<b>GHMxx38</b>	2.5	5.1
<b>GHMxx40</b>	3.6	4.9
<b>GHMxx43</b>	3.2	6.1
<b>GHMxx45</b>	5.4	6.1

\*1 4.0±0.1mm in case of GHM1038

\*Nominal Value  
(in mm)

### ② Paper Tape

8mm width 4mm pitch Tape ( $T=1.0$  rank)

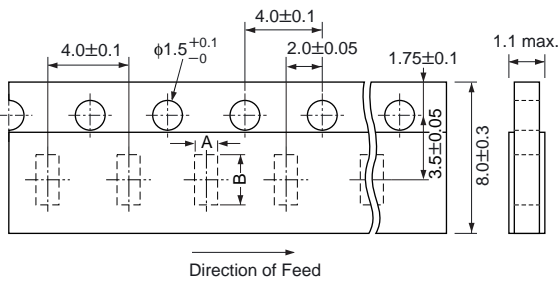

Part Number	A*	B*
<b>GHMxx25</b>	1.45	2.25
<b>GHMxx30</b>	2.0	3.6

\*Nominal value  
(in mm)

### (3) Dimensions of Reel

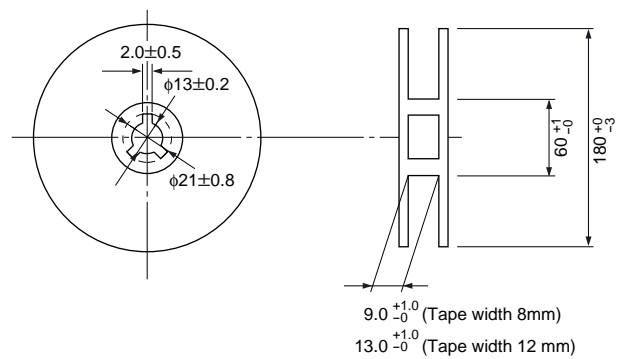

(in mm)

## Package

### (4) Taping Method

- ① Tapes for capacitors are wound clockwise. The sprocket holes are to the right as the tape is pulled toward the user.
- ② Part of the leader and part of the empty tape shall be attached to the end of the tape as follows.
- ③ The top tape or cover tape and base tape are not attached at the end of the tape for a minimum of 5 pitches.
- ④ Missing capacitors number within 0.1% of the number per reel or 1 pc, whichever is greater, and are not continuous.
- ⑤ The top tape or cover tape and bottom tape shall not protrude beyond the edges of the tape and shall not cover sprocket holes.
- ⑥ Cumulative tolerance of sprocket holes, 10 pitches :  $\pm 0.3\text{mm}$ .
- ⑦ Peeling off force : 0.1 to 0.7N in the direction shown on the right.

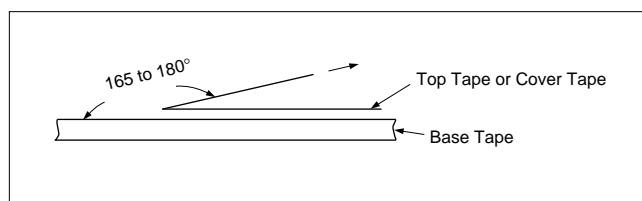
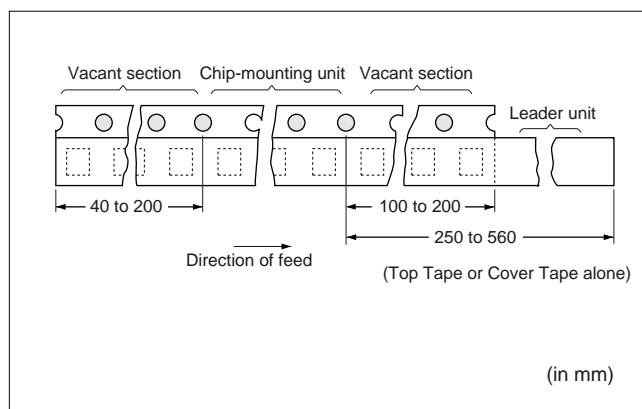

DataSheet4U.com



## ⚠ Caution

### ■ Storage and Operating Conditions

Do not use or store capacitors in a corrosive atmosphere, especially where chloride gas, sulfide gas, acid, alkali, salt or the like are present and avoid exposure to moisture.

Before cleaning, bonding or molding this product, verify that these processes do not affect product quality by testing the performance of a cleaned, bonded or

molded product in the intended equipment.

Store the capacitors where the temperature and relative humidity do not exceed 5 to 40 degrees centigrade and 20 to 70%. Use capacitors within 6 months.

Failure to follow the above cautions may result, worst case, in a short circuit and fuming when the product is used.

### ■ Handling

Vibration and impact

Do not expose a capacitor to excessive shock or vibration during use.

Failure to follow the above cautions may result, worst case, in a short circuit and fuming when the product is used.

### ■ Caution (Rating)

#### 1. Operating Voltage

Be sure to use a capacitor only within its rated operating voltage range. When DC-rated capacitors are to be used in AC or ripple voltage circuits, be sure to maintain the Vp-p value of the applied voltage within the rated voltage range.

#### 2. Operating Temperature and Self-generated Heat

Keep the surface temperature of a capacitor within the rated operating temperature range.

Be sure to take into account the heat produced by the capacitor itself. When a capacitor is used in a high-frequency circuit, pulse voltage circuit or the like, it may produce heat due to dielectric loss.

Keep such self-generated temperature below 20°C in B(X7R) characteristic products.

Regarding R and SL characteristic products, the applied voltage should be limited in high frequency circuit.

Please contact our sales representatives or engineers for more details.

specified voltage value is applied, the defective may be caused.

#### (2) Voltage Applied Method

When the withstanding voltage is applied, capacitor's lead or terminal shall be firmly connected to the out-put of the withstanding voltage test equipment, and then the voltage shall be raised from near zero to the test voltage. If the test voltage without the raise from near zero voltage would be applied directly to capacitor, test voltage should be applied with the \*zero cross. At the end of the test time, the test voltage shall be reduced to near zero, and then capacitor's lead or terminal shall be taken off the out-put of the withstanding voltage test equipment.

If the test voltage without the raise from near zero voltage would be applied directly to capacitor, the surge voltage may arise, and therefore, the defective may be caused.

\*ZERO CROSS is the point where voltage sine wave pass 0V.

-See the right figure-

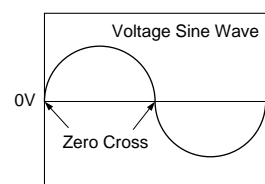

#### 3. Test Condition for AC Withstanding Voltage

##### (1) Test Equipment

Test equipment for AC withstanding voltage shall be used with the performance of the wave similar to 50/60 Hz sine wave.

If the distorted sine wave or over load exceeding the

Failure to follow the above cautions may result, worst case, in a short circuit and fuming when the product is used.

**Caution**

## ■ Caution (Soldering and Mounting)

### 1. Vibration and Impact

Do not expose a capacitor to excessive shock or vibration during use.

### 2. Circuit Board Material

Please contact our sales representatives or engineers in case that GHM products (size 4.5×3.2mm and over) are to be mounted upon a metal-board or metal-frame.

Soldering heat causes the expansion and shrinkage of a board or frame. which may result in chip-cracking.

### 3. Land Layout for Cropping PC Board

Choose a mounting position that minimizes the stress imposed on the chip during flexing or bending of the board.

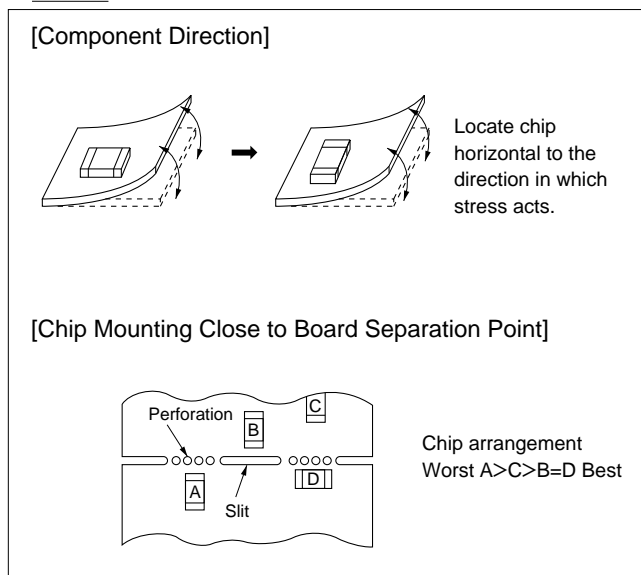

Continued on the following page.

DataSheet4U.com

et4U.com

DataShee

DataSheet4U.com

www.DataSheet4U.com

## ⚠ Caution

Continued from the preceding page.

### 4. Soldering (Prevention of the thermal shock)

If a chip component is heated or cooled abruptly during soldering, it may crack due to the thermal shock. To prevent this, adequate soldering condition should be taken following our recommendation below.

Carefully perform pre-heating so that temperature difference ( $\Delta T$ ) between the solder and component surface should be in the following range. When components are immersed in solvent after mounting, pay special attention to maintain the temperature difference within  $100^{\circ}\text{C}$ .

Chip Size	3.2×1.6mm and under	3.2×2.5mm and over
Soldering Method		
Reflow Method or Soldering Iron Method	$\Delta T \leq 190^{\circ}\text{C}$	$\Delta T \leq 130^{\circ}\text{C}$
Flow Method or Dip Soldering Method	$\Delta T \leq 150^{\circ}\text{C}$	—

When soldering chips with a soldering iron, it should be performed in following conditions.

Item	Conditions	
Chip Size	$\leq 2.0 \times 1.25\text{mm}$	$3.2 \times 1.6\text{mm}$
Temperature of Iron-tip	$300^{\circ}\text{C}$ max.	$270^{\circ}\text{C}$ max.
Soldering Iron Wattage	20W max.	
Diameter of Iron-tip	$\phi 3.0\text{mm}$ max.	
Soldering Time	3 sec. max.	
Caution	Do not allow the iron-tip to directly touch the ceramic element.	

Infrared Reflow Soldering Conditions (Example)

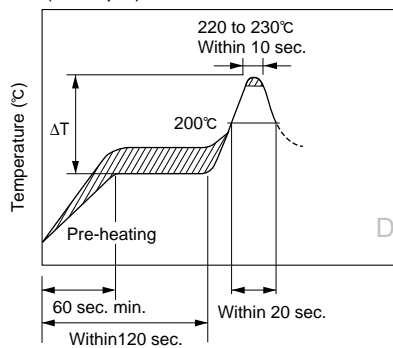

Vapor Reflow Soldering (VPS) Conditions (Example)

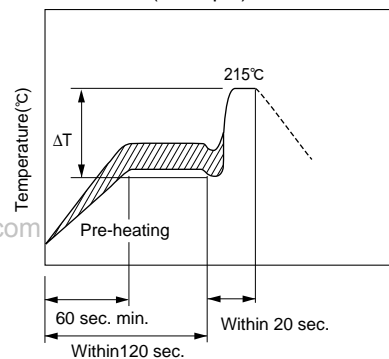

Flow Soldering Conditions (Example)

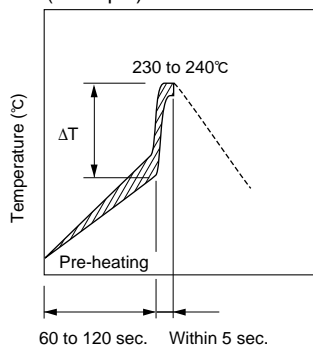

Dip Soldering/Soldering Iron Conditions (Example)

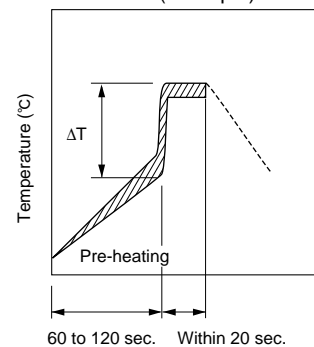

### 5. Soldering Method

GHM products whose sizes are  $3.2 \times 1.6\text{mm}$  and under for flow and reflow soldering, and other sizes for reflow soldering.

Be sure to contact our sales representatives or engineers in case that GHM products (size  $3.2 \times 2.5\text{mm}$  and over) are to be mounted with flow soldering. It may crack due to the thermal shock.

Failure to follow the above cautions may result, worst case, in a short circuit and fuming when the product is used.

1. Mounting of Chips

● Mechanical shock of the chip placer

When the positioning claws and pick up nozzle are worn, the load is applied to the chip while positioning is concentrated to one position, thus causing cracks, breakage, faulty positioning accuracy, etc.

Careful checking and maintenance are necessary to prevent unexpected trouble.

An excessively low bottom dead point of the suction nozzle imposes great force on the chip during mounting, causing cracked chips. Please set the suction nozzle's bottom dead point on the upper surface of the board.

Termination Thickness of Chip Capacitor and Desirable Thickness of Adhesives Applied

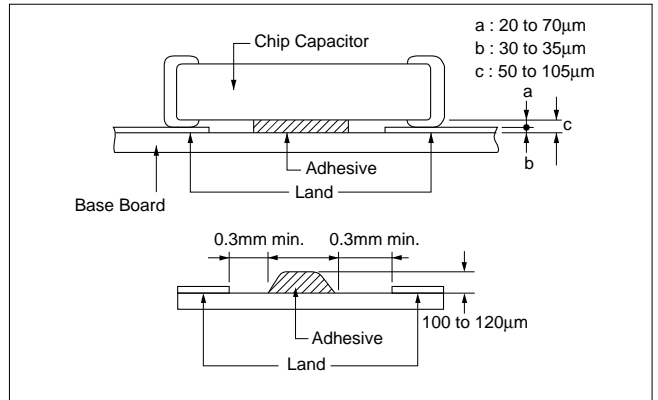

2. Construction of Board Pattern

After installing chips, if solder is excessively applied to the circuit board, mechanical stress will cause destruction resistance characteristics to lower. To prevent this, be extremely careful in determining shape and dimension before designing the circuit board diagram.

Construction and Dimensions of Pattern (Example)

Diagram illustrating the construction and dimensions of a pattern for a chip capacitor. Labels include: Chip Capacitor, Slit, Solder Resist, Land, L, W, a, b, c, d, e.

Preparing slit help flux cleaning and resin coating on the back of the capacitor.

L×W	a	b	c
2.0×1.25	1.0-1.2	0.9-1.0	0.8-1.1
3.2×1.6	2.2-2.6	1.0-1.1	1.0-1.4

L×W	a	b	c	d	e
2.0×1.25	1.0-1.2	0.9-1.0	0.8-1.1	-	-
3.2×1.6	2.2-2.4	0.8-0.9	1.0-1.4	1.0-2.0	3.2-3.7
3.2×2.5	2.0-2.4	1.0-1.2	1.8-2.3	1.0-2.0	4.1-4.6
4.5×2.0	2.8-3.4	1.2-1.4	1.4-1.8	1.0-2.8	3.6-4.1
4.5×3.2	2.8-3.4	1.2-1.4	2.3-3.0	1.0-2.8	4.8-5.3
5.7×2.8	4.0-4.6	1.4-1.6	2.1-2.6	1.0-4.0	4.4-4.9
5.7×5.0	4.0-4.6	1.4-1.6	3.5-4.8	1.0-4.0	6.6-7.1

(in mm)

Land Layout to Prevent Excessive Solder

	Mounting Close to a Chassis	Mounting with Leaded Components	Mounting Leaded Components Later
Examples of Arrangements to be Avoided			
Examples of Improvements by the Land Division			

## Notice

Continued from the preceding page.

### 3. Soldering

(Care for minimizing loss of the terminations.)

Limit of losing effective area of the terminations and conditions needed for soldering.

Depending on the conditions of the soldering temperature and/or immersion (melting time), effective areas may be lost in some part of the terminations.

To prevent this, be careful in soldering so that any possible loss of the effective area on the terminations will securely remain minimum 25% on all edge length A-B-C-D of part with A, B, C, D, shown in the Figure below.

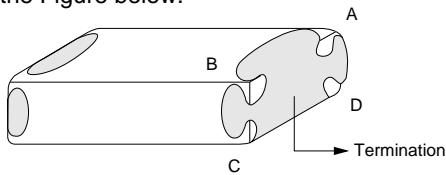

Soldering Allowance Time

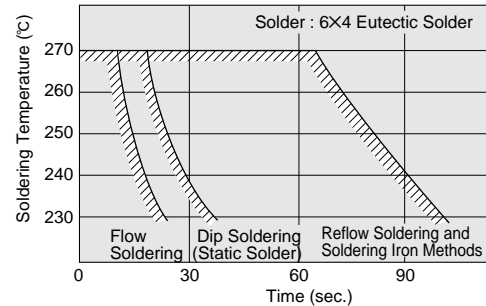

In case of repeated soldering, the accumulated soldering time must be within the range shown above.

#### (2) Flux and Solder

- Use rosin-type flux and do not use a highly acidic flux (any containing a minimum of 0.2wt% chlorine).
- Please use 6Z4 eutectic solder, or 5Z5 solder. (Do not use solder with silver.)

#### (3) Solder Buildup

##### ① Flow soldering and iron soldering

Use as little solder as possible, and confirm that the solder is securely placed.

[Solder Buildup by Flow Method and Soldering Iron Method]

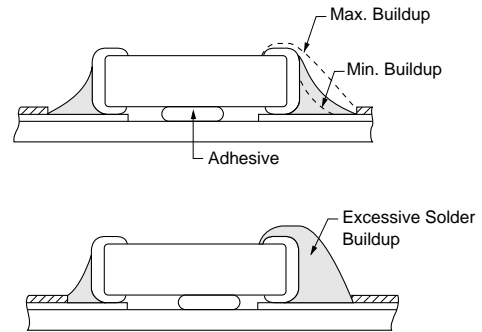

##### ② Reflow soldering

When soldering, confirm that the solder is placed over 0.2mm of the surface of the terminations.

[Solder Buildup by Reflow Method]

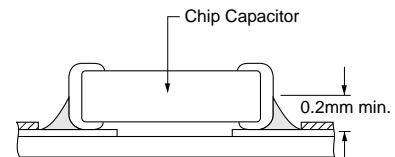

### 4. Cleaning

To perform ultrasonic cleaning, observe the following conditions on the right.

Rinse bath capacity : Output of 20 watts per liter or less.  
Rinsing time : 5 minutes maximum.

### 5. Resin Coating

- When selecting resin materials, select those with low contraction and low moisture absorption coefficient (generally epoxy resin is used).
- Buffer coat can decrease the influence of the resin shrinking (generally silicone resin).

## ■ISO9000 CERTIFICATIONS

Manufacturing plants of these products in this catalog have obtained the ISO9001 or ISO9002 certificate.

Plant	Certified Date	Organization	Registration NO.
Fukui Murata Manufacturing Co.,Ltd.	Mar. 31, '95	RCJ★ ISO9001	RCJ-85M-01C
Izumo Murata Manufacturing Co.,Ltd.	May. 11, '95		RCJ-93M-05A
Murata Electronics Singapore (Pte.) Ltd.	Aug. 13, '92	SISIR★★ ISO9002	SG MES 91M001A
Murata Manufacturing (UK) Ltd.	Nov. 18, '92	BSI★★★ ISO9002	FM 22169
Murata Amazonia Industria Comercio Ltda.	Sep. '93	RCJ★ ISO9002	RCJ-(B)-93M-01
Murata Electronics North America State College Plant	Jun. '94	UL★★★★ ISO9002	A1734

- ★ RCJ : Reliability Center for Electronic Components of Japan
- ★★ SISIR : Singapore Institute of Standards and Industrial Research
- ★★★ BSI : British Standards Institution
- ★★★★ UL : Underwriters Laboratories Inc.

DataSheet4U.com

et4U.com

DataShee

DataSheet4U.com

**⚠ Note:****1. Export Control**

〈For customers outside Japan〉

Murata products should not be used or sold for use in the development, production, stockpiling or utilization of any conventional weapons or mass-destructive weapons (nuclear weapons, chemical or biological weapons, or missiles), or any other weapons.

〈For customers in Japan〉

For products which are controlled items subject to the "Foreign Exchange and Foreign Trade Law" of Japan, the export license specified by the law is required for export.

**2. Please contact our sales representatives or product engineers before using our products listed in this catalog for the applications listed below which require especially high reliability for the prevention of defects which might directly cause damage to the third party's life, body or property, or when intending to use one of our products for other applications than specified in this catalog.**

- ① Aircraft equipment
- ② Aerospace equipment
- ③ Undersea equipment
- ④ Power plant equipment
- ⑤ Medical equipment
- ⑥ Transportation equipment (vehicles, trains, ships, etc.)
- ⑦ Traffic signal equipment
- ⑧ Disaster prevention / crime prevention equipment
- ⑨ Data-processing equipment
- ⑩ Application of similar complexity and/or reliability requirements to the applications listed in the above

**3. Product specifications in this catalog are as of July 2000. They are subject to change or our products in it may be discontinued without advance notice. Please check with our sales representatives or product engineers before your ordering. If there are any questions, please contact our sales representatives or product engineers.****4. The parts numbers and specifications listed in this catalog are for information only. You are requested to approve our product specification or to transact the approval sheet for product specification, before your ordering.****5. Please note that unless otherwise specified, we shall assume no responsibility whatsoever for any conflict or dispute that may occur in connection with the effect of our and/or third party's intellectual property rights and other related rights in consideration of your using our products and/or information described or contained in our catalogs. In this connection, no representation shall be made to the effect that any third parties are authorized to use the rights mentioned above under licenses without our consent.****6. None of ozone depleting substances (ODS) under the Montreal Protocol is used in manufacturing process of us.****Murata Manufacturing Co., Ltd.**<http://www.murata.co.jp/products/>

**Head Office**  
2-26-10, Tenjin Nagaokakyo-shi, Kyoto 617-8555, Japan Phone:81-75-955-6502

**International Division**  
3-29-12, Shibuya, Shibuya-ku, Tokyo 150-0002, Japan  
Phone:81-3-5469-6123 Fax:81-3-5469-6155 E-mail:intl@murata.co.jp

DataSheet4U.com