

|       |           |       |          |      |
|-------|-----------|-------|----------|------|
| ISSUE | REVISIONS | DRAWN | APPROVED | DATE |
|-------|-----------|-------|----------|------|

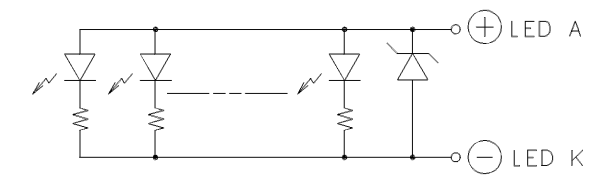

液晶之友 电话: 020-33819057  
 Http://www.lcdfriends.com

CIRCUIT DIAGRAM



QTY of LED chips  
 351851AE : 7chips

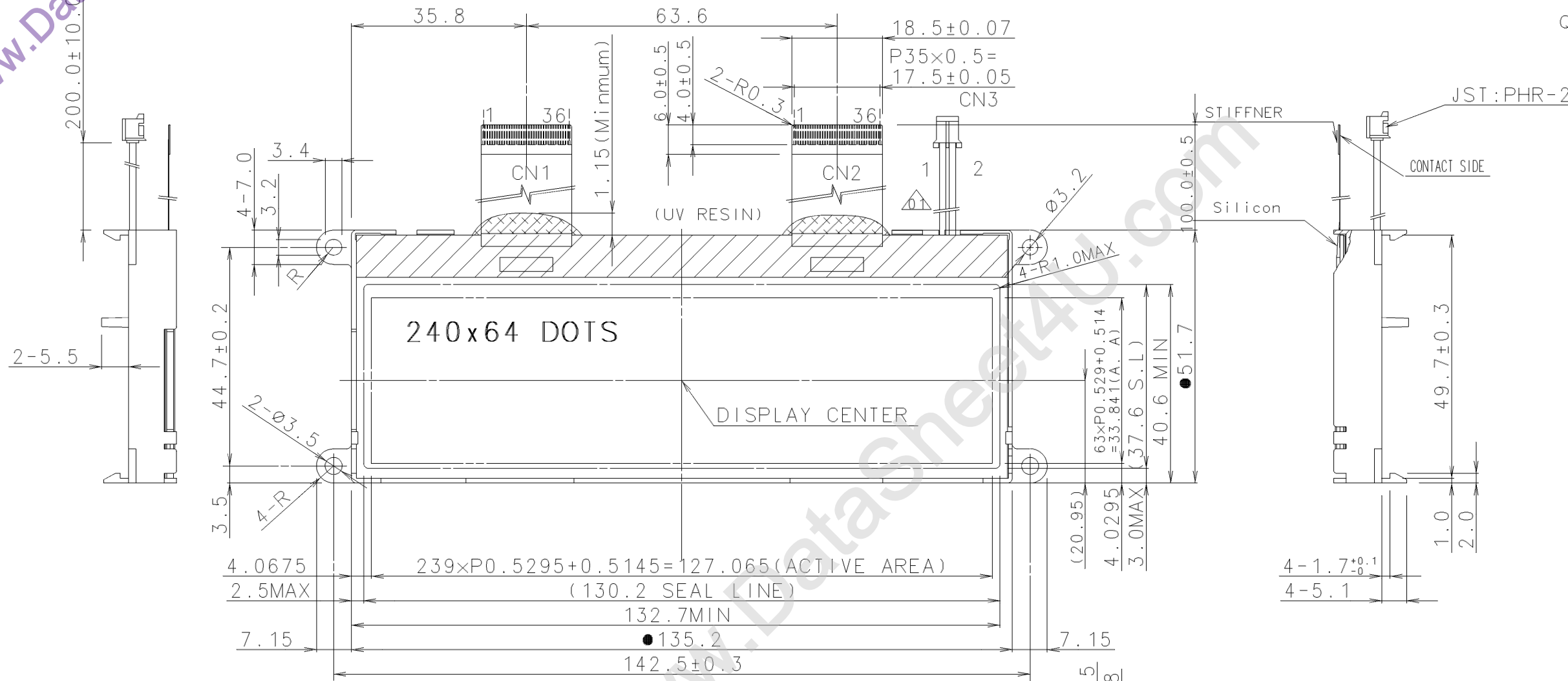

PIN ASSIGNMENT

| CN1-MASTER (IC1)<br>CN2-SLAVE (IC2) |        |     |        |
|-------------------------------------|--------|-----|--------|
| No.                                 | Symbol | No. | Symbol |
| 1                                   | NC     | 19  | VDD    |
| 2                                   | FR     | 20  | VSS    |
| 3                                   | CL     | 21  | VOUT   |
| 4                                   | DOF    | 22  | C3-    |
| 5                                   | CS1    | 23  | C1+    |
| 6                                   | CS2    | 24  | C1-    |
| 7                                   | RES    | 25  | C2-    |
| 8                                   | A0     | 26  | C2+    |
| 9                                   | WR     | 27  | V1     |
| 10                                  | RD     | 28  | V2     |
| 11                                  | D0     | 29  | V3     |
| 12                                  | D1     | 30  | V4     |
| 13                                  | D2     | 31  | V5     |
| 14                                  | D3     | 32  | VR     |
| 15                                  | D4     | 33  | C86    |
| 16                                  | D5     | 34  | P/S    |
| 17                                  | D6     | 35  | NC     |
| 18                                  | D7     | 36  | NC     |

| CN3 |         |
|-----|---------|
| No. | Symbol  |
| 1   | ANODE   |
| 2   | CATHODE |

NOTE 1. ● MARK SETTING DIMENSIONS : SPECIAL CHARACTERISTICS.  
 2. HATCHED AREA ON LCD TERMINAL LEDGE SHOWS MAXIMUM AREA OF SILICON RESIN.

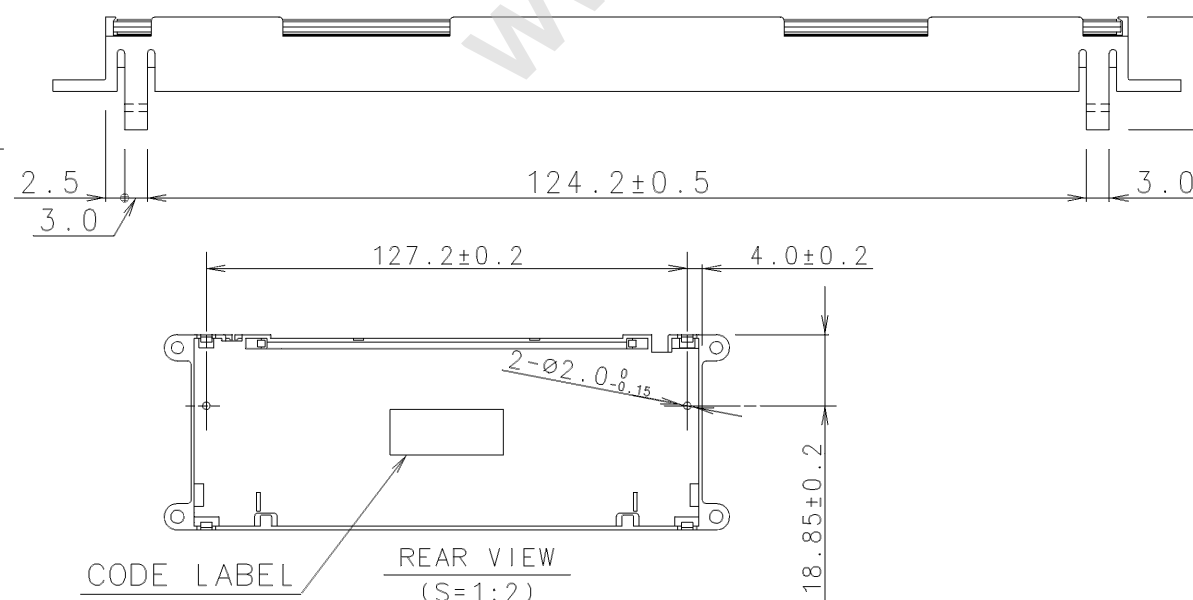
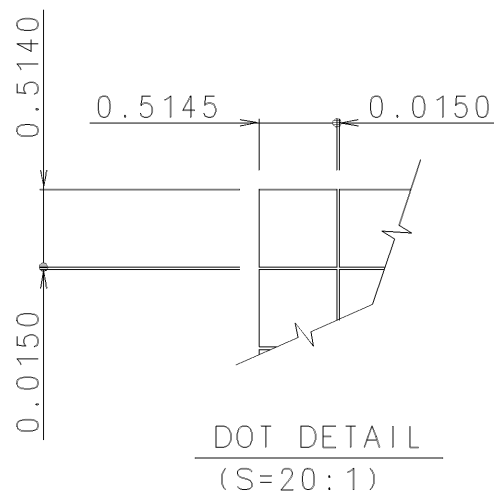

| MEASURE   | TOLERANCE |      |      | THIRD ANGLE PROJECTION | DATE<br>Feb.25'05       |
|-----------|-----------|------|------|------------------------|-------------------------|
|           | A         | B    | C    |                        |                         |
| L≤16      | ±0.1      | ±0.3 | ±1   | UNIT                   | APPROVED<br>M.MOTOHASHI |
| 16<L≤63   | ±0.2      | ±0.5 | ±1.5 | mm                     | CHECKED<br>T.SUZUKI     |
| 63<L≤250  | ±0.3      | ±0.8 | ±2   | SCALE                  | DRAWN<br>X.Hawk         |
| 250<L≤500 | ±0.5      | ±1.2 | ±3   | 1:1                    |                         |
| 500<L     | ±0.8      | ±2   | ±4   |                        |                         |
| ANGLE     | ±1°       | ±5°  | ±10° |                        |                         |

OPTREX CORPORATION  
 DIMENSIONAL OUTLINE  
 F-1851 AE base  
 DWG NO  
 UE-312372