



■ 技术参数 TECHNICAL PARAMETR

1. 间距 Pitch: 1.0mm
2. 额定电流 Current Rating: 0.5A AC/DC.
3. 额定电压 Voltage Rating: 50V AC/DC.
4. 温度范围 Temperature range: -40°C~+85°C
5. 耐压 Withstand Voltage: 500V/min
6. 接触电阻 Contact resistance: $\leq 0.03\Omega$
7. 绝缘电阻 Insulation resistance: $\geq 800M\Omega$
8. 适用印刷电路板厚度
Applicable PC board thickness: 0.8~1.6mm

■ 材料 Material

1. 外壳 Housing: PA46/PA6T UL94V-0
2. 接触片 Contact: Phosphor bronze, Copper & Tin plating

■ 卧式 (SMT) 双触点 Side Entry Double Contact

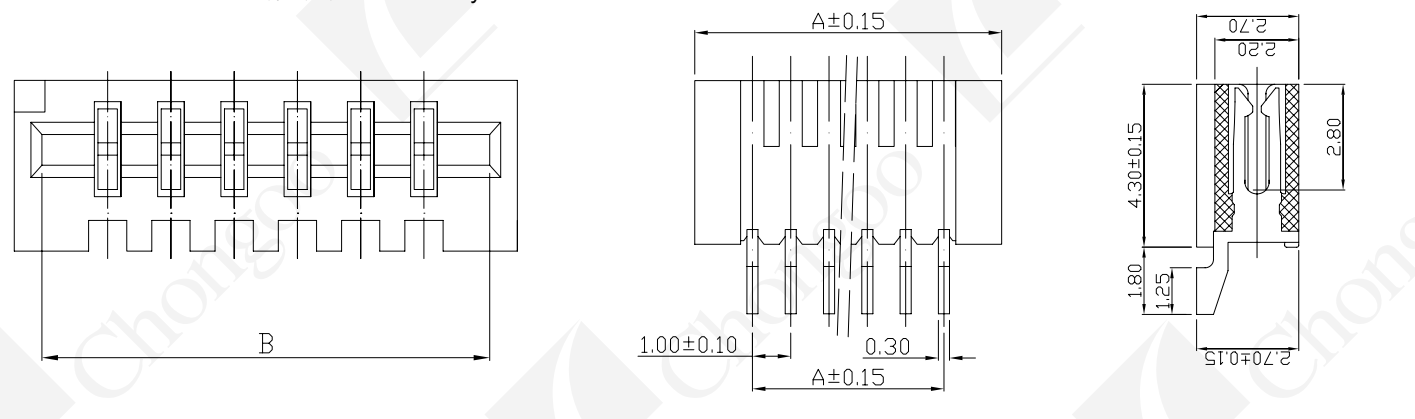

■ 印刷电路板 PC board layout

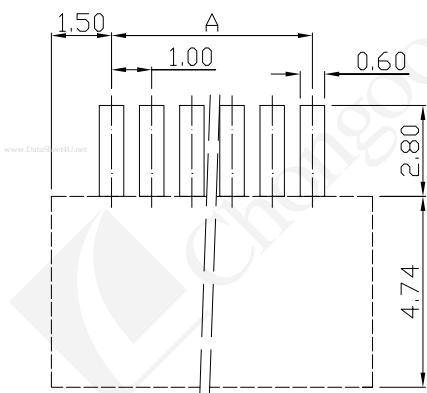

■ 适用FFC/FPC Applicable FFC/FPC

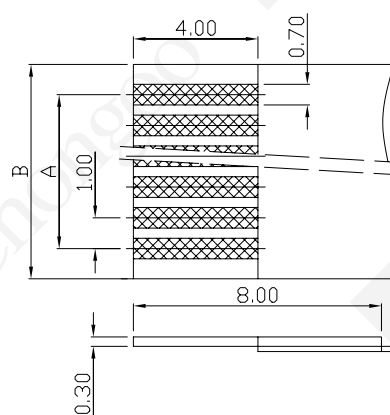

■ 编号与尺寸

Ordering Informftion & Dimensions

| PART No. | A | B | C | PART No. | A | B | C | PART No. | A | B | C |
|-------------|-------|-------|-------|-------------|-------|-------|-------|-------------|-------|-------|-------|
| FPC1.0E-4P | 3.00 | 5.00 | 6.00 | FPC1.0E-17P | 16.00 | 18.00 | 19.00 | FPC1.0E-30P | 29.00 | 31.00 | 32.00 |
| FPC1.0E-5P | 4.00 | 6.00 | 7.00 | FPC1.0E-18P | 17.00 | 19.00 | 20.00 | FPC1.0E-31P | 30.00 | 32.00 | 33.00 |
| FPC1.0E-6P | 5.00 | 7.00 | 8.00 | FPC1.0E-19P | 18.00 | 20.00 | 21.00 | FPC1.0E-32P | 31.00 | 33.00 | 34.00 |
| FPC1.0E-7P | 6.00 | 8.00 | 9.00 | FPC1.0E-20P | 19.00 | 21.00 | 22.00 | FPC1.0E-33P | 32.00 | 34.00 | 35.00 |
| FPC1.0E-8P | 7.00 | 9.00 | 10.00 | FPC1.0E-21P | 20.00 | 22.00 | 23.00 | FPC1.0E-34P | 33.00 | 35.00 | 36.00 |
| FPC1.0E-9P | 8.00 | 10.00 | 11.00 | FPC1.0E-22P | 21.00 | 23.00 | 24.00 | FPC1.0E-35P | 34.00 | 36.00 | 37.00 |
| FPC1.0E-10P | 9.00 | 11.00 | 12.00 | FPC1.0E-23P | 22.00 | 24.00 | 25.00 | FPC1.0E-36P | 35.00 | 37.00 | 38.00 |
| FPC1.0E-11P | 10.00 | 12.00 | 13.00 | FPC1.0E-24P | 23.00 | 25.00 | 26.00 | FPC1.0E-37P | 36.00 | 38.00 | 39.00 |
| FPC1.0E-12P | 11.00 | 13.00 | 14.00 | FPC1.0E-25P | 24.00 | 26.00 | 27.00 | FPC1.0E-38P | 37.00 | 39.00 | 40.00 |
| FPC1.0E-13P | 12.00 | 14.00 | 15.00 | FPC1.0E-26P | 25.00 | 27.00 | 28.00 | FPC1.0E-39P | 38.00 | 40.00 | 41.00 |
| FPC1.0E-14P | 13.00 | 15.00 | 16.00 | FPC1.0E-27P | 26.00 | 28.00 | 29.00 | FPC1.0E-40P | 39.00 | 41.00 | 42.00 |
| FPC1.0E-15P | 14.00 | 16.00 | 17.00 | FPC1.0E-28P | 27.00 | 29.00 | 30.00 | | | | |
| FPC1.0E-16P | 15.00 | 17.00 | 18.00 | FPC1.0E-29P | 28.00 | 30.00 | 31.00 | | | | |