

KEYING PLUG	
PART NUMBER	COLOR●
1-640415-0	White
1-640415-1	Natural

● White color is flame-retardant, 94V-0, nylon material. Natural color is 94V-2 nylon material.

NOTE: All illustrations shown without wires for clarity.

Figure 1

1. INTRODUCTION

This instruction sheet covers the installation of Universal MATE-N-LOK keying plugs and strain relief assemblies.

NOTE  Dimensions on this sheet are in metric units [with U.S. customary units in brackets]. Figures and illustrations are for reference only and are not drawn to scale.

Reasons for reissue of this document are provided in Section 5, REVISION SUMMARY.

2. DESCRIPTION

Keying plugs are one-piece nylon parts that provide additional polarization for the connectors.

Strain relief assemblies relieve the strain of the wires on the contacts. There are two strain relief assembly versions: open and enclosed. The open version is available for 2 through 15 circuit plug housings. The enclosed version is available for 2 through 15 circuit plug or cap housings. The enclosed version also features the option of an attached insert for smaller wire bundles. Adapters are required when installing an enclosed strain relief assembly onto a cap connector.

3. KEYING PLUG (Figure 1)

Keying plugs may be inserted into the plug or the cap connector. Proceed as follows:

1. Locate contact cavity to be keyed on FRONT (mating end) of connector.
2. Align split, tapered end of plug with contact cavity. Insert plug straight into cavity until it snaps into position.

NOTE  Corresponding contact cavity in mating connector must be empty for connectors to engage.

4. STRAIN RELIEF ASSEMBLY

4.1. Open Version ((Figure 2)

Two identical open version strain reliefs are attached to the plug connector as follows:

1. Insert mounting legs of one strain relief in slots provided at back of plug connector.
2. Insert mounting legs of second strain relief in same slots, but facing the opposite direction.

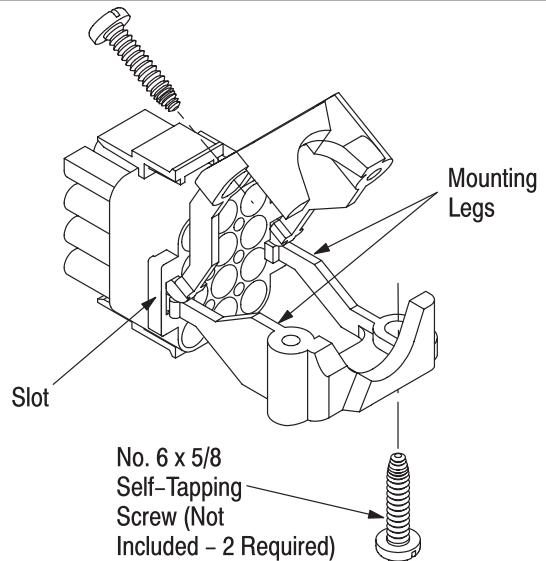

OPEN VERSION STRAIN RELIEF ASSEMBLY		
NUMBER OF CIRCUITS	PART NUMBER	COLOR●
2, 3, 4, 5, 6, and 8 In-Line Version	350811-1	White
	1-350589-0	Natural
6, 9, 12, and 15 Matrix Version	350812-1	White
	1-350590-0	Natural

● White color is flame-retardant, 94V-0, nylon material. Natural color is 94V-2 nylon material.

NOTE: Two strain reliefs are required per connector.

Figure 2

3. Position the wire bundle between the two strain reliefs and secure the strain reliefs together with

two No. 6 pan head self-tapping screws (not included). Do NOT pull the wire bundle when securing the strain reliefs.

4.2. Enclosed Version

A. Plug Connector (Figure 3)

Two identical enclosed version strain reliefs are attached to the plug connector as follows:

1. Insert hook of one strain relief in slot provided at back of plug connector.
2. Insert hook of second strain relief in slot provided at back of plug connector, opposite first strain relief slot.
3. Install strain relief inserts if needed for small wire bundles.
4. Position the wire bundle between the two strain reliefs and secure the strain reliefs together with two No. 6 pan head self-tapping screws (not included). Do NOT pull the wire bundle when securing the strain reliefs.

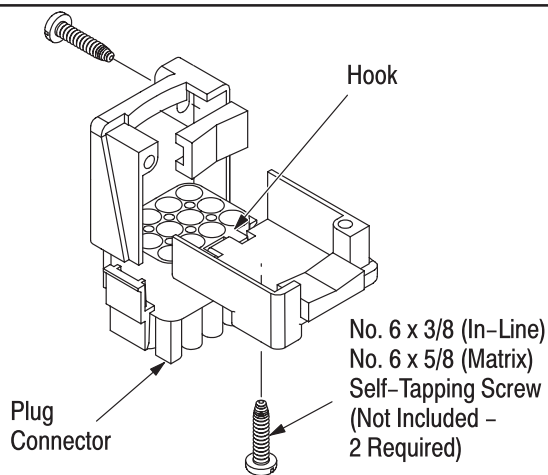

ENCLOSED VERSION STRAIN RELIEF ASSEMBLY			
STYLE	NUMBER OF CIRCUITS	PART NUMBER	
		WHITE●	NATURAL●
In-Line	2	640713	640719
	3	640714	640720
	4	641776	641775
	5	643030	643030
	6	643313	643585
	8	643314	—
Matrix	6	640715	640721
	9	640716	640722
	12	640717	640723
	15	640718	640724

● White color is flame-retardant, 94V-0, nylon material. Natural color is 94V-2 nylon material.

NOTE: Two strain reliefs are required per connector.

NOTE: Catalog 82181 provides complete part number listings and descriptions.

Figure 3

B. Cap Connector (Figure 4)

Select two identical cap housing adapters and enclosed strain reliefs. Attach the adapters and strain reliefs to the cap connector as follows:

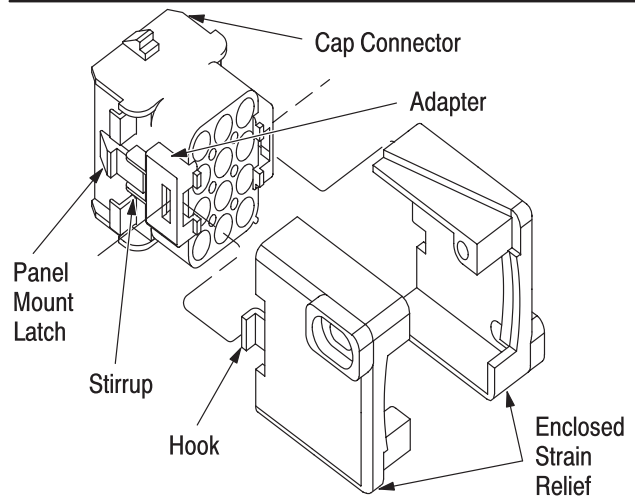

CAP HOUSING ADAPTER

NUMBER OF CIRCUITS	PART NUMBER	COLOR●
3, 4, and 5 In-Line and 9, 12, and 15 Matrix Versions	641777-1	Natural
	641778-1	White
2 In-Line and 6 Matrix Versions	643182-1	Natural
	643182-2	White

● White color is flame-retardant, 94V-0, nylon material. Natural color is 94V-2 nylon material.

NOTE: There is no adapter available for 6 or 8 position in-line cap housings. Two adapters are required per connector.

Figure 4

1. Hold adapter with logo facing the same direction as the mating end of the connector.
2. Slide the adapter stirrup over the panel mount latch. Approximately 1/3 of the way along the latch, rotate the adapter 90° toward the connector until stirrup is bottomed on the latch base. The adapter should be flush with the connector.
3. Insert strain relief hook into slot provided on back of adapter. Rotate strain relief 90° toward wire bundle.
4. Repeat Steps 1, 2, and 3 on the other side of the connector.
5. Install strain relief inserts if needed for small wire bundles.
6. Position the wire bundle between the two strain reliefs and secure the strain reliefs together with two No. 6 pan head self-tapping screws (not included). Do NOT pull the wire bundle when securing the strain reliefs.

5. REVISION SUMMARY

- New format