

# DP-650 Series

## Miniature LCD Display Digital Panel Meters



### Description

The DP-650 Series is an ultra-compact, low-power LCD meter requiring only 15mW of power. This meter is ideal for applications requiring a highly reliable LCD display in a small package. The snap-in bezel packaging enables easy and rapid installation of the meter. The simplicity of design, overvoltage protection, and low power consumption all contribute to the high reliability of this device.

Three input voltage ranges are available:  $\pm 200\text{mV}$ ,  $\pm 2\text{VDC}$ , and  $\pm 20\text{VDC}$ . A 4-20mA current input adapter (DP-670) is also offered. Automatic polarity, overrange indication, adjustable decimal point, and display HOLD are standard features. The DP-650 Series employs a dual slope integrating A/D converter, and operates from an internal 100mV reference via a precision DC-to-DC converter. Typical accuracy is  $\pm 0.1\%$ .

### Features

- Convenient snap-in bezel package
- Very low power consumption (5VDC @ 3mA)
- Differential input, 3 voltage ranges
- 0.1% typical accuracy
- User-selectable decimal point
- Hold-display function
- Overvoltage protection
- Quantity discounts

### Technical Notes

1. The connection shown utilizes differential inputs. For single-ended operation, INPUT(-) is strapped to GND. If the signal is isolated from the power source, connect INPUT(-) to GND either directly or through a 10K resistor network as shown to reduce common mode errors.
2. Display holds reading when HOLD is high (+5V). Readings are updated when HOLD is low or floating.
3. The decimal point is user selectable by connecting the decimal point pins (4, 5, or 6) to DP COM (pin 3).
4. Full-scale input span is adjusted prior to shipment. Further calibration is possible by adjusting the trimpot mounted on the back of the DPM.
5. Unused pins should be left open.

### Applications

- Portable/mobile equipment
- Medical instruments
- Avionics/aerospace systems
- Office equipment

### Ordering Information

Model	Description
DP-650	Miniature DPM LCD $\pm 200\text{mV}$
DP-652	Miniature DPM LCD $\pm 2\text{V}$
DP-654	Miniature DPM LCD $\pm 20\text{V}$
APS-5	120V AC to 5V DC Power Supply
C-10	Connector - 10 pin

www.DataSheet4U.com

# DP-650 Series

## Dimensions

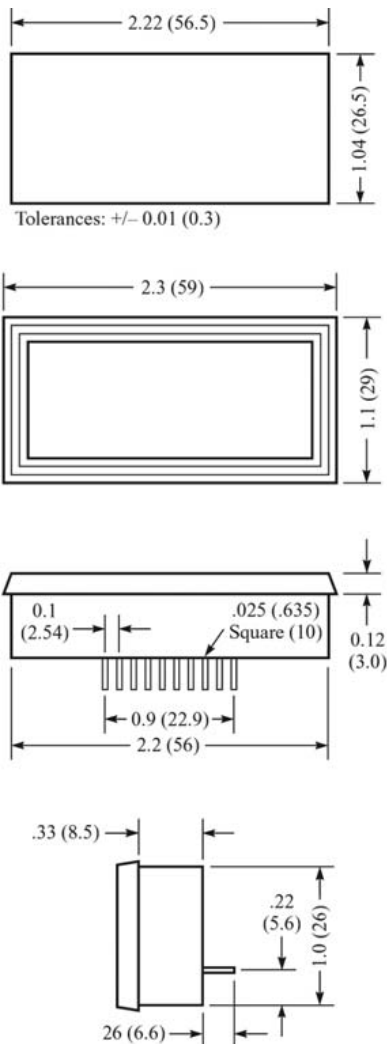

inches (mm)

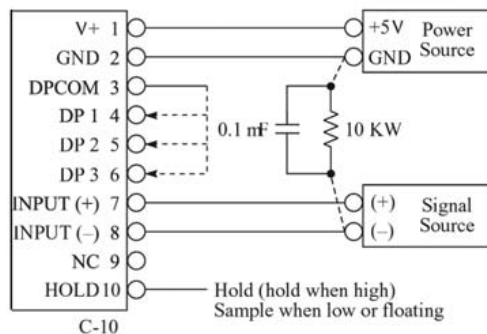

## Connections

Pin No.	Pin Name	Description
1	V+	+5V power supply
2	GND	Power supply ground
3	DP COM	Decimal point return
4	DP1	1XX.X (connect to DP COM to turn on)
5	DP2	1X.XX (connect to DP COM to turn on)
6	DP3	1.XXX (connect to DP COM to turn on)
7	INPUT(+)	Positive input signal
8	INPUT(-)	Negative input signal (see Technical Note 1)
9	NC	No connection required
10	HOLD	Hold last display (see Technical Note 2)

## Specifications

Display	Digits	3½ (±1999 count)
	Type	7-segment LCD
	Digit Height	.39in (10mm)
	Polarity Indication	Automatic - for neg input
	Decimal Point	3 position selectable
	Overrange Indication	1--- for positive, -1--- for negative
	Other Features/Options	Display hold function
Signal Inputs	Configuration	Bipolar, differential
	Full-Scale Input	±200mV, ±2V, ±20V
	Input Offset Adjustment	Auto zero
	Input Impedance	10MΩ (±200mV), 1MΩ (other ranges)
	Common Mode Range	±1VDC
	Common Mode Rejection	>86dB
	Overrange Protection	±350VDC (±100 VDC for 200mV range)
Performance	Input Bias Current	1pA typical, 100pA max
	Control Inputs	Decimal point select, hold function
	Sampling Rate	3.3 readings/s
	Accuracy	±(0.1% + 2 counts) typ, ±(0.2% + 2 counts) max
	Warmup, typical	10 min
	Temperature Drift, typical	100 ppm/°C
	Power Supply Requirements	Supply Voltage
	Supply Current, typical	3mA
Physical	Package Style	Snap-in bezel mount
	Dimensions	2.30 x 1.10 x .71
	Panel Cutout	2.22 x 1.04
	Weight	0.7oz (20g)
	Connector	C-10 (10-pin) optional
	Bezel	Snap-in bezel included
Environmental Requirements	Operating Temperature	0 to 50°C
	Storage Temperature	-10 to 60°C
	Relative Humidity	0 to 95% non-condensing

www.DataSheet4U.com