



Push-Pull Low Power Transformer

EPC3115S-X & EPC3115S-X-LF

- Designed for use with Maxim Max253/Max3535E
- Add "-LF" after part number for Lead-Free
- Used in SMPS Push-Pull Topology
- UL 94V-0 Recognized Components
- UL 1446 Class B Insulation System
- Switching Frequency : 350 KHz
- 8 Pin SOIC PCMCIA Package
- 700 Vdc Minimum Isolation
- Very Low Core Loss

Electrical Parameters @ 25° C

PCA Part Number	Voltage (V)		Primary OCL (μH Typ.)	Turns Ratio (Pri. :Sec.)	ET (V-μSec.)	Duty Cycle (%)	Rectification (Half or Full Wave)
	V in	V out					
			@ 100 KHz, 0.1 Vrms	Pri. :Sec.	@ 350 KHz		Connections
EPC3115S-1	3.3	5	394	1:1:2:2	7.1	75	† Output Center Tap
EPC3115S-2	5	5	988	1:1:1.3:1.3	11	75	† Output Center Tap
	5	10	988	1:1:1.3:1.3	11	75	Voltage Doubler
*EPC3115S-3	5	10	988	1:1:2.67:2.67	11	75	† Output Center Tap
*EPC3115S-4	5	12	988	1:1:3:3	11	80	† Output Center Tap
	5	24	988	1:1:3:3	11	80	Voltage Doubler
EPC3115S-5	3.3	5	394	1:1:1:1	7.1	75	Voltage Doubler
EPC3115S-6	5	5	988	1:1:.67:.67	11	75	Voltage Doubler
EPC3115S-7	5	12	988	1:1:1.5:1.5	11	80	Voltage Doubler
EPC3115S-8	5	15	988	1:1:2:2	11	75	Voltage Doubler

- † Connections : Output Center Tap as Common/Return
- Operating Temperature : -40°C to +85°C

Package

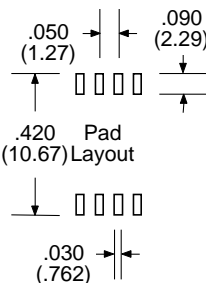
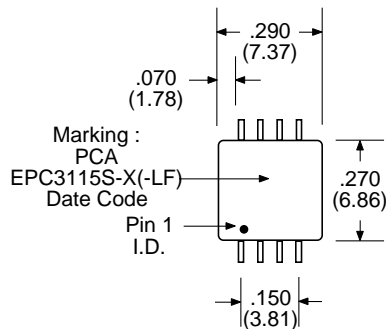

*.098 Max. (2.49) for EPC3115S-3/-4

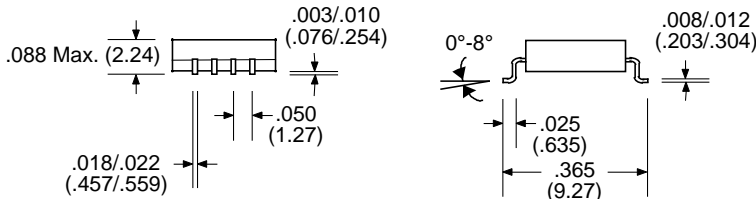

Schematic

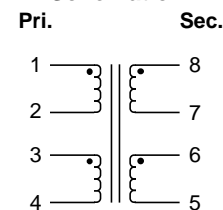

Application

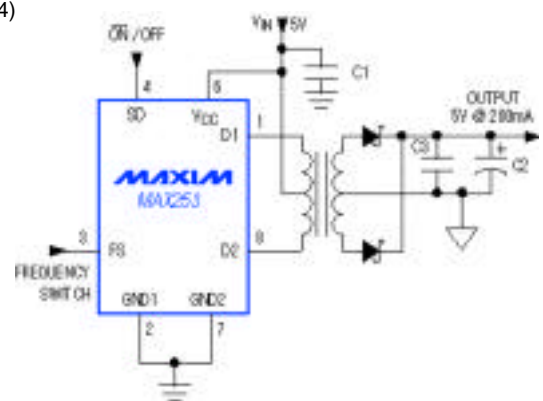

Notes :	EPC3115S-X	EPC3115S-X-LF
1. Assembly Process (Solder Composition)	SnPb	Pb-Free
2. Peak Solder Rating (per IPC/JEDEC-J-STD-020C)	225°C	260°C
3. Moisture Sensitive Levels (MSL) (per IPC/JEDEC-J-STD-020C)	1 (Unlimited, 30°C/60%RH)	1 (Unlimited, 30°C/60%RH)
4. Weight	TBD grams	TBD grams
5. Packaging Information (Tube)	TBD pcs / tube	TBD pcs / tube

Unless Otherwise Specified Dimensions are in Inches /mm ± .010 / .25