



A Unit of Teledyne Electronics and Communications

## ESTABLISHED RELIABILITY TO-5 RELAYS SENSITIVE DPDT

# SERIES 432

SERIES DESIGNATION	RELAY TYPE
432	DPDT basic relay
432D	DPDT relay with internal diode for coil transient suppression
432DD	DPDT relay with internal diodes for coil transient suppression and polarity reversal protection
432T	DPDT relay with internal transistor driver and coil transient suppression diode

### INTERNAL CONSTRUCTION

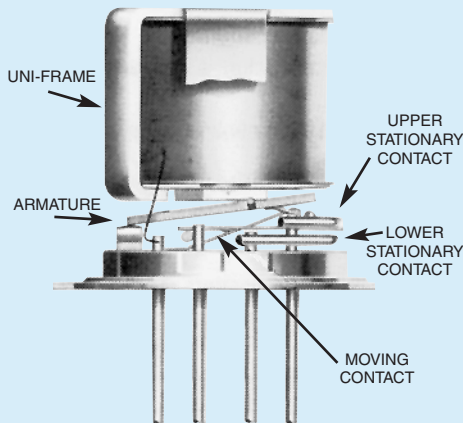

### DESCRIPTION

The TO-5 relay, originally conceived and developed by Teledyne, has become one of the industry standards for low-level switching from dry circuit to 1 ampere. Designed for high-density PC board mounting, its small size and low coil power dissipation make the 432 relay one of the most versatile ultraminiature relays available.

The following unique construction features and manufacturing techniques provide excellent resistance to environmental extremes and overall high reliability.

- All welded construction.
- Unique uni-frame design, providing high magnetic efficiency and mechanical rigidity.
- High force/mass ratios for resistance to shock and vibration.
- Advanced cleaning techniques provide maximum assurance of internal cleanliness.
- Precious metal alloy contact material with gold plating assures excellent high current and dry circuit switching capabilities.

The Series 432D and 432DD relays have internal discrete silicon diodes for coil suppression and polarity reversal protection. The hybrid 432T relay has an internal silicon suppression diode and a transistor driver. This hybrid package reduces required PC board floor space by reducing the number of external components needed to drive the relay.

By virtue of its inherently low intercontact capacitance and contact circuit losses, the 432 relay has shown its worth as an RF switch for frequency ranges well into the UHF spectrum (see Figure 1). In addition, the sensitive Series 432 relay has a high resistance coil, thus requiring extremely low operating power (200 milliwatts, typical at room temperature). The advantages of reduced heat dissipation and power supply demands are a plus.

### ENVIRONMENTAL AND PHYSICAL SPECIFICATIONS

Temperature (Ambient)	-65°C to +125°C
Vibration (General Note 1)	30 g's to 3000 Hz
Shock (General Note 1)	75 g's, 6 msec, half-sine
Acceleration	50 g's
Enclosure	Hermetically sealed
Weight	0.159 oz. (4.5g) max.

**SERIES 432**  
**GENERAL ELECTRICAL SPECIFICATIONS** (-65°C to +125°C unless otherwise noted) (Notes 2 & 3)

<b>Contact Arrangement</b>	2 Form C (DPDT)	
<b>Rated Duty</b>	Continuous	
<b>Contact Resistance</b>	0.1 ohm max. before life; 0.2 ohm max. after life at 1A/28Vdc (measured 1/8" from header)	
<b>Contact Load Ratings (DC)</b> (See Fig. 2 for other DC resistive voltage/current ratings)	Resistive: 1 Amp/28Vdc Inductive: 200 mA/28Vdc (320 mH) Lamp: 100 mA/28Vdc Low Level: 10 to 50 µA/10 to 50mV	
<b>Contact Load Ratings (AC)</b>	Resistive: 250 mA/115Vac, 60 and 400 Hz (Case not grounded) 100 mA/115Vac, 60 and 400 Hz (Case grounded)	
<b>Contact Life Ratings</b>	10,000,000 cycles (typical) at low level 1,000,000 cycles (typical) at 0.5A/28Vdc resistive 100,000 cycles min. at all other loads specified above	
<b>Contact Overload Rating</b>	2A/28Vdc Resistive (100 cycles min.)	
<b>Contact Carry Rating</b>	Contact factory	
<b>Coil Operating Power</b>	200 milliwatts typical at nominal rated voltage @ 25°C	
<b>Operate Time</b>	4.0 msec max. at nominal rated coil voltage	
<b>Release Time</b>	432 Series: 2.0 msec max. 432D, 432DD, 432T Series: 7.5 msec max.	
<b>Contact Bounce</b>	1.5 msec max.	
<b>Intercontact Capacitance</b>	0.4 pf typical	
<b>Insulation Resistance</b>	10,000 megohms min. between mutually isolated terminals	
<b>Dielectric Strength</b>	Atmospheric pressure: 500 Vrms/60Hz	70,000 ft.: 125 Vrms/60Hz
<b>Negative Coil Transient (Vdc)</b>	432D, 432DD, 432T	1.0 max
<b>Diode P.I.V. (Vdc)</b>	432D, 432DD, 432T	100 min.
<b>432T Transistor Characteristics</b>	<b>Base Turn Off Voltage (Vdc)</b>	0.3 min.
	<b>Emitter-base breakdown Voltage (BV<sub>EB0</sub>) (@25°C) (Vdc)</b>	6.0 min.
	<b>Collector-base breakdown Voltage (BV<sub>CB0</sub>) (@25°C &amp; I<sub>c</sub> = 100 µA) (Vdc)</b>	75 min.

ESTABLISHED RELIABILITY

**DETAILED ELECTRICAL SPECIFICATIONS** (-65°C to +125°C unless otherwise noted) (Note 3)

BASE PART NUMBERS (See Note 10 for full P/N example)	➔	432-5	432-6	432-9	432-12	432-18	432-26	
		432D-5 432DD-5 432T-5	432D-6 432DD-6 432T-6	432D-9 432DD-9 432T-9	432D-12 432DD-12 432T-12	432D-18 432DD-18 432T-18	432D-26 432DD-26 432T-26	
<b>Coil Voltage (Vdc)</b>	Nom.	5.0	6.0	9.0	12.0	18.0	26.5	
	Max.	7.5	10.0	15.0	20.0	30.0	40.0	
<b>Coil Resistance (Ohms ±10% @25°C)</b>	432, 432D, 432T (Note 4)	100	200	400	850	1600	3300	
	432DD (Note 4)	64	125	400	850	1600	3300	
<b>Coil Current (mAdc @25°C) (432DD Series)</b>	Min.	56.8	36.3	18.1	11.7	9.6	7.0	
	Max.	78.1	48.9	23.6	15.0	12.2	8.8	
<b>Coil Current (mAdc @25°C) (432T Series)</b>	(Note 7) Min.	43.5	26.4	19.7	12.2	9.7	6.9	
	Max.	59.3	35.4	25.8	16.7	13.1	9.5	
<b>Pick-up Voltage (Vdc, Max.)</b>	432, 432D	3.5	4.5	6.8	9.0	13.5	18.0	
	432DD	3.7	4.8	8.0	11.0	14.5	19.0	
	432T (Note 7)	3.6	4.8	7.8	11.0	14.5	19.0	
<b>Base Current to Turn On (mAdc, Max.) (432T Series) (Note 7)</b>		1.50	1.00	0.75	0.47	0.38	0.24	
<b>Drop-out Voltage (Vdc)</b>	432, 432D, 432T (Note 7)	Min.	0.14	0.18	0.35	0.41	0.59	0.89
		Max.	2.5	3.2	4.9	6.5	10.0	13.0
	432DD	Min.	0.7	0.8	0.9	1.0	1.1	1.3
		Max.	2.6	3.0	4.5	5.8	9.0	13.0

**PERFORMANCE CURVES**  
(NOTE 2)

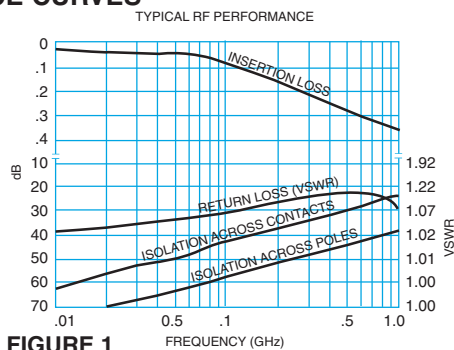

FIGURE 1

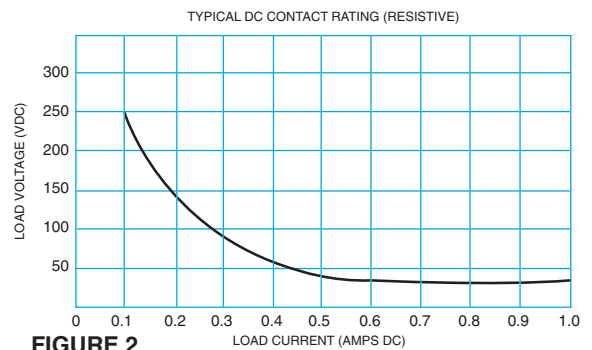
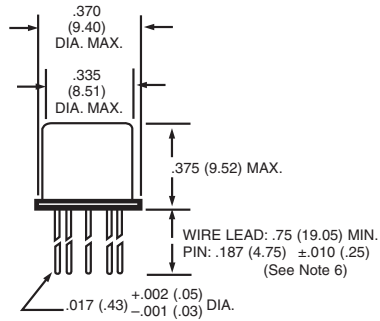
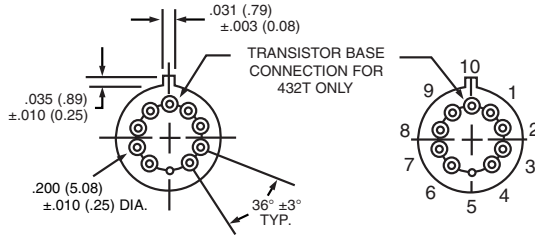

FIGURE 2

**OUTLINE DIMENSIONS**



**TERMINAL LOCATIONS AND PIN NUMBERING (REF. ONLY)**  
(Viewed from Terminals)



DIMENSIONS ARE SHOWN IN INCHES (MILLIMETERS)

**SCHEMATIC DIAGRAMS**

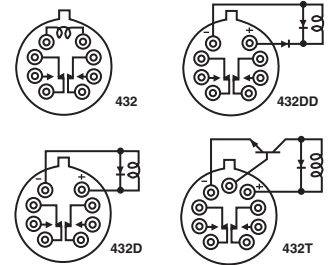

SCHEMATICS ARE VIEWED FROM TERMINALS

**GENERAL NOTES**

1. Relay contacts will exhibit no chatter in excess of 10  $\mu$ sec or transfer in excess of 1  $\mu$ sec.
2. "Typical" characteristics are based on available data and are best estimates. No on-going verification tests are performed.
3. Unless otherwise specified, parameters are initial values.
4. For reference only. Coil resistance not directly measurable at relay terminals due to internal series semiconductor. 432DD and 432T only.
5. Unless otherwise specified, relays will be supplied with either gold-plated or solder-coated leads.
6. The slash and characters appearing after the slash are not marked on the relay.
7. Limit Base Emitter current to 15 mA dc.
8. Applicable to all coil voltages. See Base current to turn on.
9. Screened HI-REL versions available. Contact factory.
- 10.

**TYPICAL LOGIC INTERFACE**

(See Note 8)

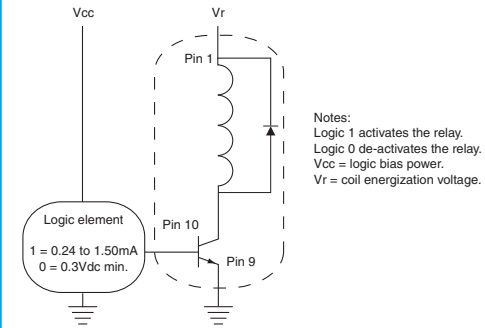

Teledyne Part Numbering System for  $T^2R^{\circledR}$  Established Reliability Relay

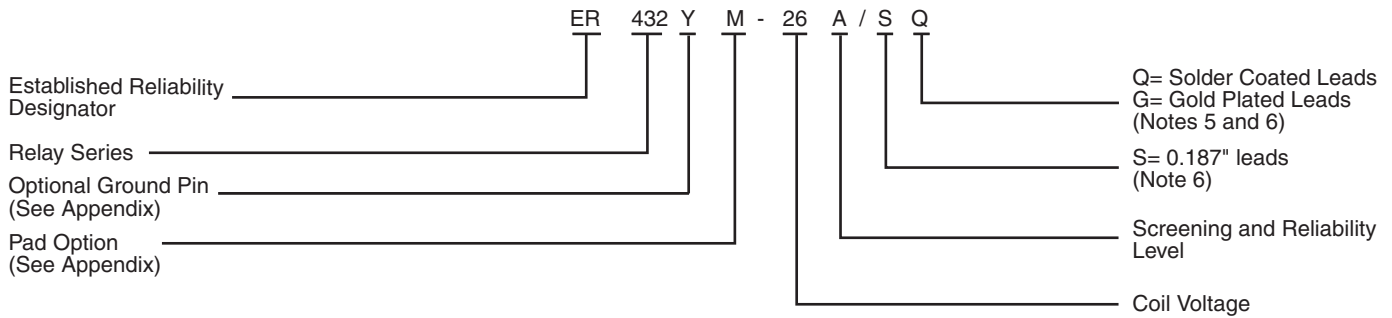

Teledyne Part Numbering System for Military Qualified (JAN) Relays

