

SOLID STATE RELAY (I/O Module)

MAXIMUM LOAD CURRENT 1 A

SN SERIES

■ FEATURES

- I/O modules for interface between CPU and external input devices or loads
- Ultra slim and light weight, SIL terminals type I/O modules for high density mounting
 - Size: 5 (W) × 20 (L) × 17 (H) mm
 - Weight: approximately 3.0 to 3.5 g
- High isolation by employing photo-coupled devices (between input and output: 2,500 V rms)
- Long life and maintenance free
- All solid state I/O module
- Compatible with NY relay size and terminals arrangement (only output module type)



■ ORDERING INFORMATION

- INPUT MODULE

[Example] $\frac{SN}{(a)}$ - $\frac{A}{(b)}$ $\frac{100 BF}{(c)}$

(a)	Series Name	SN : SN Series
(b)	Input Voltage	A : AC type D : DC type
(c)	Nominal Voltage	100 BF : 100 VAC 200 BF : 200 VAC 12/24 B : 12/24 VDC

SN SERIES

● OUTPUT MODULE

[Example] $\frac{SN}{(a)} - \frac{12}{(b)} \frac{D}{(c)} \frac{01}{(d)} \frac{HZ}{(e)} - \frac{C}{(f)} \frac{R}{(g)} \frac{T}{(h)}$

(a)	Series Name	SN : SN Series	
(b)	Nominal Voltage (Input side)	3 : 3 VDC (only AC type) 5 : 5 VDC 12 : 12 VDC 24 : 24 VDC	
(c)	Load Voltage	A : AC type D : DC type	
(d)	Load Current	01 : 1 A	
(e)	Kinds of Inverse Connection Protecting Element	AC type	Nil : with varistor NV: without varistor
		DC type	Nil : Diode HZ: Zener diode
(f)	Zero Cross function (AC type)	F : without zero cross function C : with zero cross function	
(g)	Output Polarity (DC type)	Nil : Standard polarity R : Reverse polarity	
(h)	Switching Speed (DC type)	Nil : Standard T : High speed type	

■ SPECIFICATIONS

• INPUT MODULE (SN-() B Type)

Item		AC Input module		DC Input module		Remarks
		100 VAC Type	200 VAC Type	12/24 VDC Type		
INPUT side	Input Voltage Range	80 to 132 Vrms	160 to 265 Vrms	9.6 to 28.8 VDC		
	Rating Input Current	Approx. 7 mArms		Approx. 5 mA (at 12 VDC)	Approx. 10 mA (at 24 VDC)	
	Power Frequency Range	47 to 63 Hz		—	—	
	Must Operate Voltage (max.)	80 Vrms	160 Vrms	9.6 VDC		
	Must Release Voltage (max.)	30 Vrms	60 Vrms	5.0 VDC		
	Must Release Current (min.)	2 mArms		1.5 mA		
OUTPUT side	DC Supply Voltage	4 to 6 VDC				V _{DD}
	Maximum Output Current	±4 mA		±0.4 mA		V _{DD} = 5 V
	Output Logic	Operate with negative true logic (active low)				
Maximum Operate Time (max.)		25 ms		10 ms		
Maximum Release Time (max.)		30 ms		10 ms		
Insulation Resistance (initial value)		Minimum 1,000 MΩ (at 500 VDC)				for input-output
Dielectric Strength		2,500 Vrms 1 minute				
Operating Temperature Range		-30°C to + 85°C				no
Storage Temperature Range		-40°C to +100°C				frost
Case Color		Yellow		White		
Weight		Approximately 2.0 g		Approximately 3.3 g		

SN SERIES

• OUTPUT MODULE Standard Type

Item Remarks		AC Output module		DC Output module		
		with zero cross	without zero cross			
INPUT side	Nominal Voltage (DC)	3 V, 5 V, 12 V, 24 V		5 V, 12 V, 24 V		
	Operate Voltage Range	±20% of nominal voltage				
	Must Operate Voltage	max.80% of nominal voltage				
	Must Release Voltage	Minimum 1 VDC (minimum 0.5 V*)			*3 VDC type	
	Input Impedance (±10%)	3 VDC Type	130 Ω	180 Ω	—	
5 VDC Type		330 Ω	470 Ω	390 Ω		
12 VDC Type		1,0k Ω	1,5k Ω	1,2k Ω		
24 VDC Type		2,2k Ω	3,0k Ω	2.4k Ω		
OUTPUT side	Load Voltage Range	24 to 265 Vrms		3 to 30 VDC		
	Maximum Load Current	1.0 Arms		1.0 A	see CHARACTERISTIC DATA	
	Minimum Load Current	10 mArms		1 mA		
	Switching Current	50 A (60 Hz)		3 A (10 ms)		
	Max. Off-State Leakage Current	1.5 mArms (at 100 Vrms 60 Hz) 3.0 mArms (at 200 Vrms 60 Hz)		0.1 mA (at 30 VDC)		
	Max. On-State Voltage Drop	1.2 Vrms		1.2 V	at max. load current	
Maximum Operate Time (max.)		1 ms	1/2 cycle ±1 ms	1 ms		
Maximum Release Time		1/2 cycle + 1ms		1 ms		
Insulation Resistance		Minimum 1,000 M Ω (at 500 VDC)			for input-output	
Dielectric Strength		2,500 Vrms 1 minute				
Operating Temperature Range		-30°C to + 85°C			no	
Storage Temperature Range		-40°C to +100°C			frost	
Case Color		Black		Red		
Weight		Approximately 3.5 g		Approximately 2.9 g		

SN SERIES

• OUTPUT MODULE High Speed Switching Type

Item		AC Output module	Remarks
INPUT side	Nominal Voltage (DC)	5 V, 12 V, 24 V	
	Operate Voltage Range	±20% of nominal voltage	
	Must Operate Voltage	80% of nominal voltage	
	Must Release Voltage	Minimum 1 V	
Input Impedance	5 VDC Type	330 Ω ±10%	
	12 VDC Type	1,0 k Ω ±10%	
	24 VDC Type	2,0 k Ω ±10%	
OUTPUT side	Load Voltage	DC3 to 30V	
	Maximum Load Current	1.0 A	see CHARACTERISTIC DATA
	Minimum Load Current	1 mA	
	Switching Current	3 A (10 ms)	
	Max. Off-State Leakage Current	0.1 mA (at 30 VDC)	
	Max. On-State Voltage Drop	1.2 V	at max. load current
Maximum Operate Time		max. 5 μs	at DC 5 V 0.1A
Maximum Release Time		max. 25 μs	
Insulation Resistance		Minimum 1,000 M Ω (at 500 VDC)	for input-output
Dielectric Strength		2,500 V rms 1 minute	
Operating Temperature Range		-40°C to + 100°C	
Storage Temperature Range		-30°C to + 85°C	
Case Color		Red	
Weight		Approximately 2.9 g	

■ BLOCK DIAGRAM

• INPUT MODULE

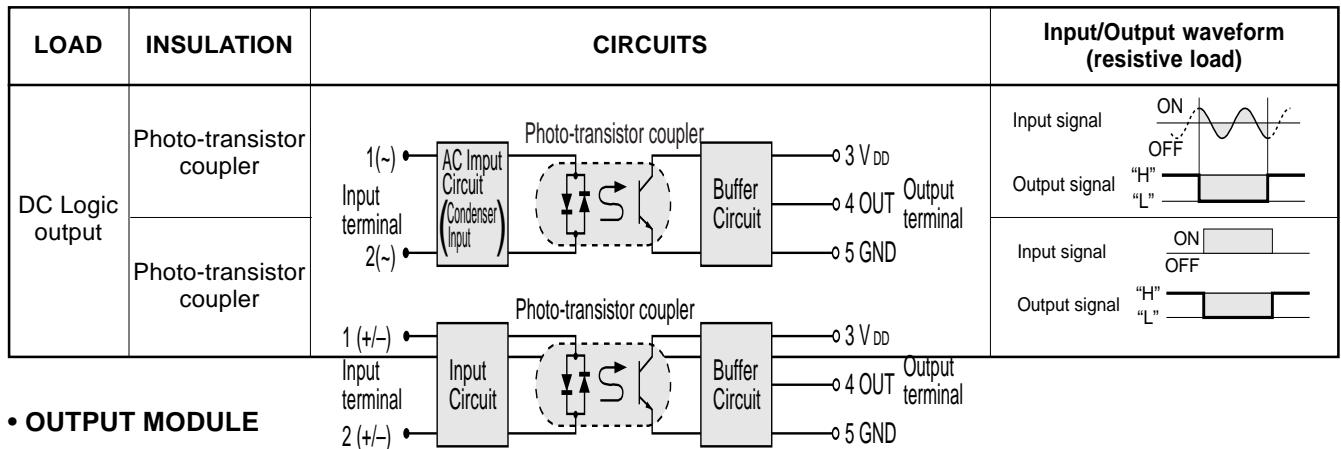

• OUTPUT MODULE

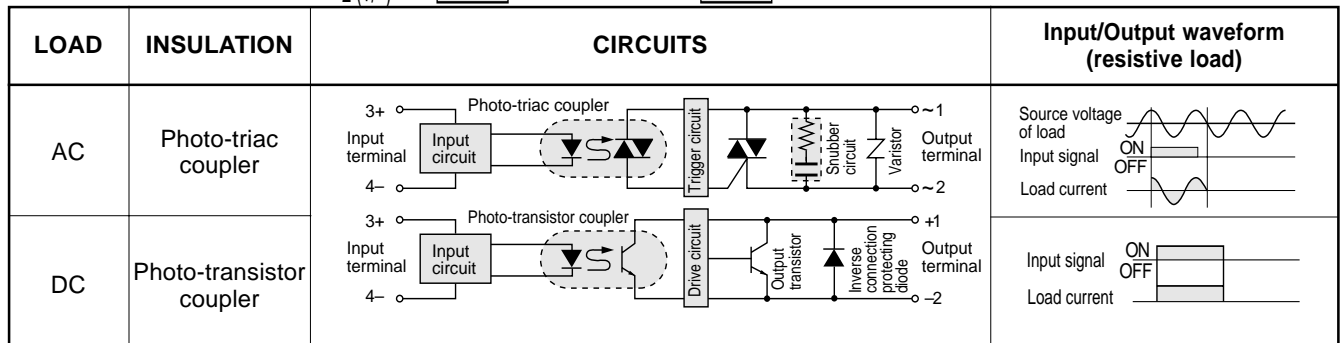

* AC type without varistor / DC type with zenor diode available.

■ CHARACTERISTIC DATA

• OUTPUT MODULE

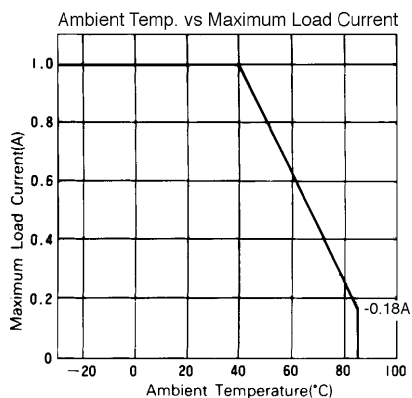

REFERENCE DATA

INPUT MODULE

Distribution of Operate & Release Voltage
(AC Type)

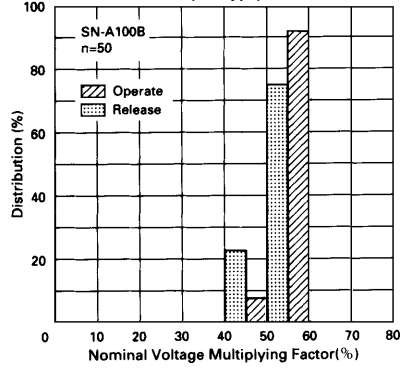

High temperature Switching Test
(AC Type)

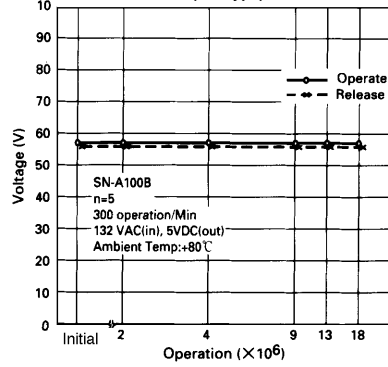

High temperature Continuous Operating Test
(AC Type)

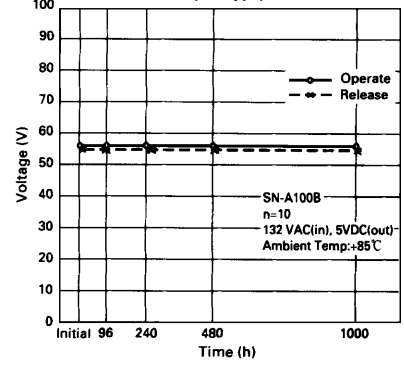

OUTPUT MODULE

Distribution of Operate & Release Voltage
(AC Type)

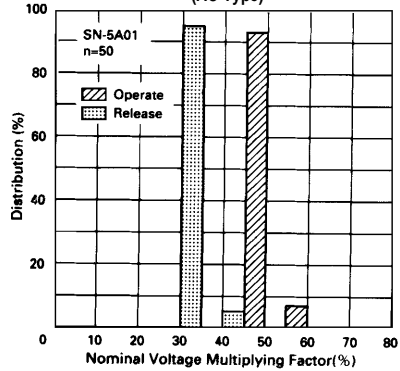

Distribution of Operate & Release Voltage
(DC Type)

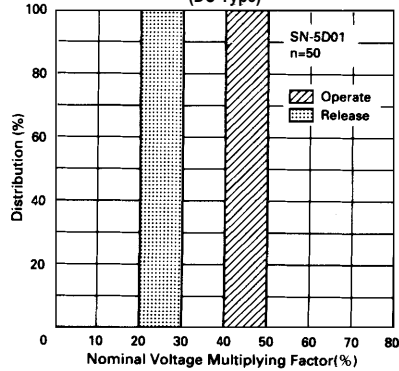

Distribution of On-State Voltage Drop
(AC Type)

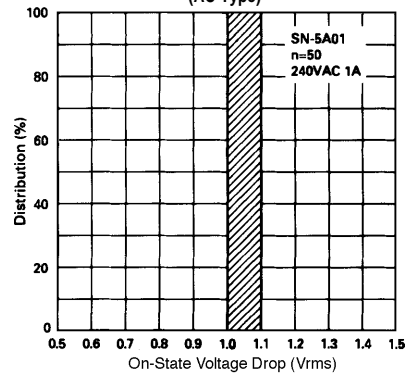

SN SERIES

■ DIMENSIONS

● Dimensions

SN-A () type (input module)

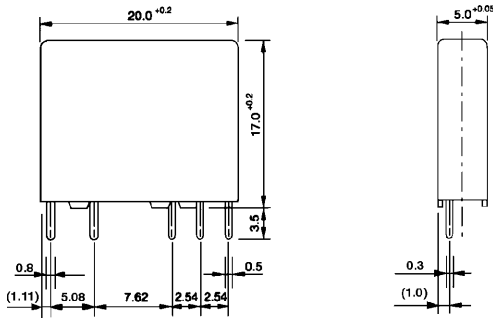

SN-D () type (input module)

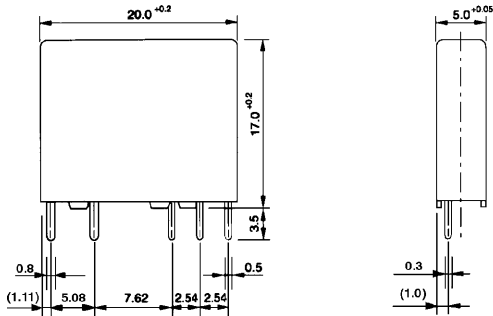

SN-A () type (output module)

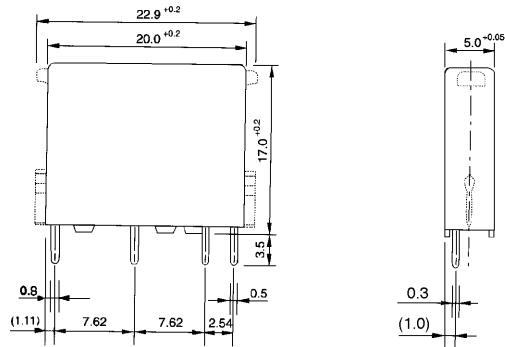

Dotted line : Socket mounting SN-()A-S type

SN-() D, ()D () R type (output module)

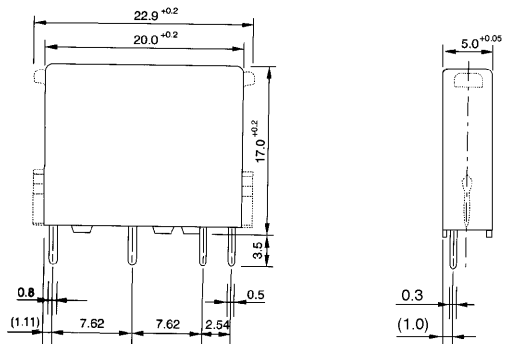

Dotted line : Socket mounting SN-()D-S type

● Schematics (BOTTOM VIEW)

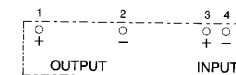
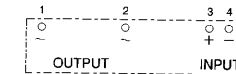
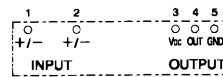
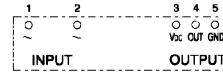

* Reverse polarity type available

● PC board mounting hole layout (BOTTOM VIEW)

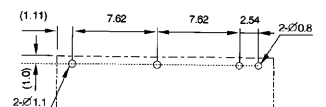
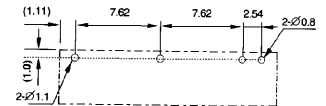
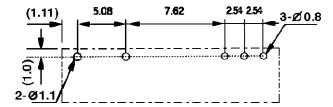
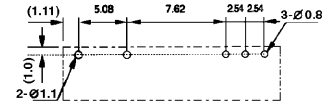

Unit: mm

■ Socket Dimensions

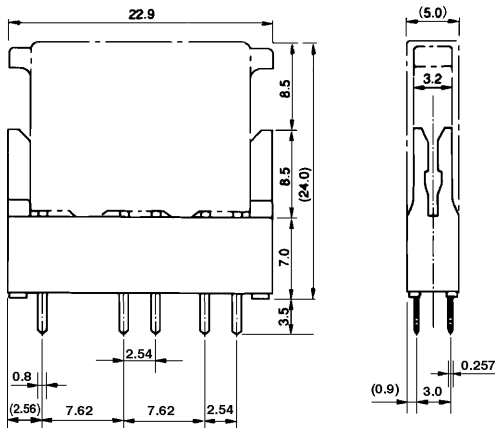

■ Socket PC board mounting hole layout (BOTTOM VIEW)

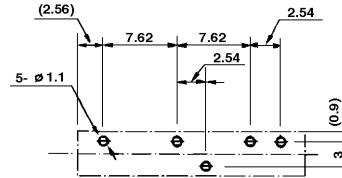

Unit: mm

■ NOTES

1. Polarity of terminals is pre-determined. Please design your circuit accordingly.
2. Socket ordering code: JL-5N
3. Standard IC socket is not recommended. Please use socket "JL-5N".
4. When switching inductive load by AC output module without varistor, please connect a varistor as shown in drawing below.
5. AC input module has inside logic IC. Please connect bypass condenser (approx. 0.01 μ) at pivotal points between VDD and GND. (Conform to general handling instructions for logic IC.)

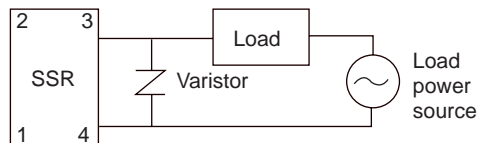

Fujitsu Components International Headquarter Offices

Japan

Fujitsu Component Limited
Gotanda-Chuo Building
3-5, Higashigotanda 2-chome, Shinagawa-ku
Tokyo 141, Japan
Tel: (81-3) 5449-7010
Fax: (81-3) 5449-2626
Email: promothq@ft.ed.fujitsu.com
Web: www.fcl.fujitsu.com

North and South America

Fujitsu Components America, Inc.
250 E. Caribbean Drive
Sunnyvale, CA 94089 U.S.A.
Tel: (1-408) 745-4900
Fax: (1-408) 745-4970
Email: marcom@fcai.fujitsu.com
Web: www.fcai.fujitsu.com

Europe

Fujitsu Components Europe B.V.
Diamantlaan 25
2132 WV Hoofddorp
Netherlands
Tel: (31-23) 5560910
Fax: (31-23) 5560950
Email: info@fceu.fujitsu.com
Web: www.fceu.fujitsu.com

Asia Pacific

Fujitsu Components Asia Ltd.
102E Pasir Panjang Road
#04-01 Citilink Warehouse Complex
Singapore 118529
Tel: (65) 6375-8560
Fax: (65) 6273-3021
Email: fcal@fcal.fujitsu.com
www.fcal.fujitsu.com